

GENERAL TECHNICAL DATA**dimensions:**

- depth: 84 cm
- height: 75 cm
- width: 299 cm

weight: 218 kg

*weight when using exotic wood

materials:

- steel: construction or stainless
- wood: domestic coniferous or exotic

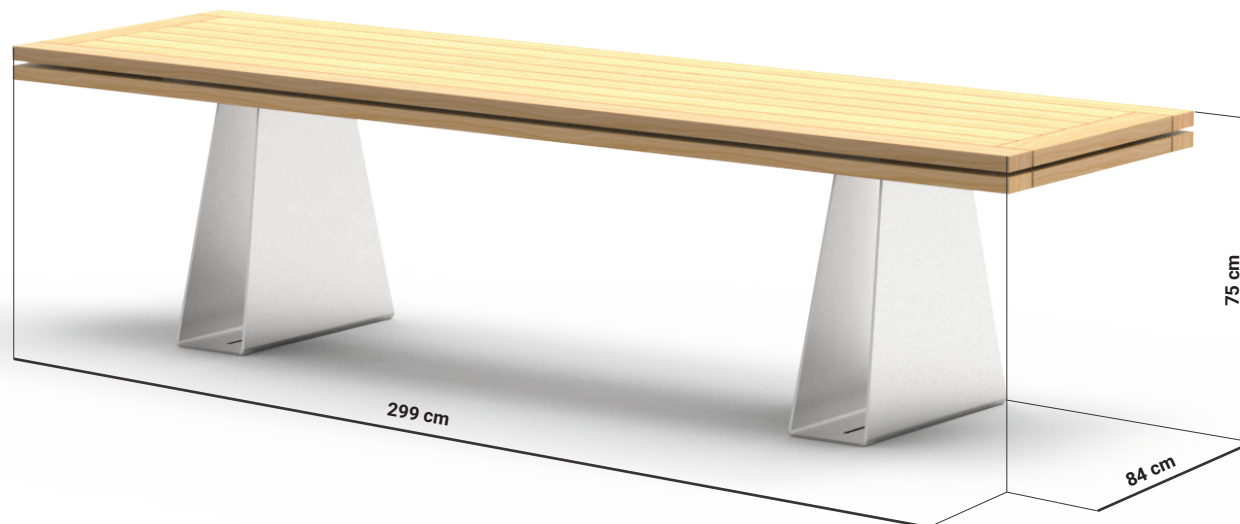
**DESCRIPTION**

Travetto table is an ideal proposal for the development of petrol stations, restaurants, parking lots. It is a large and massive table, whose table top in the basic version is made of spruce wood while the construction and legs are made of stainless steel. The table is a complement to the travetto bench.

*Filip Babiarz*

product:
TRAVETTO table 13.007
version:
designer: Filip Babiarz

FRONT VIEW

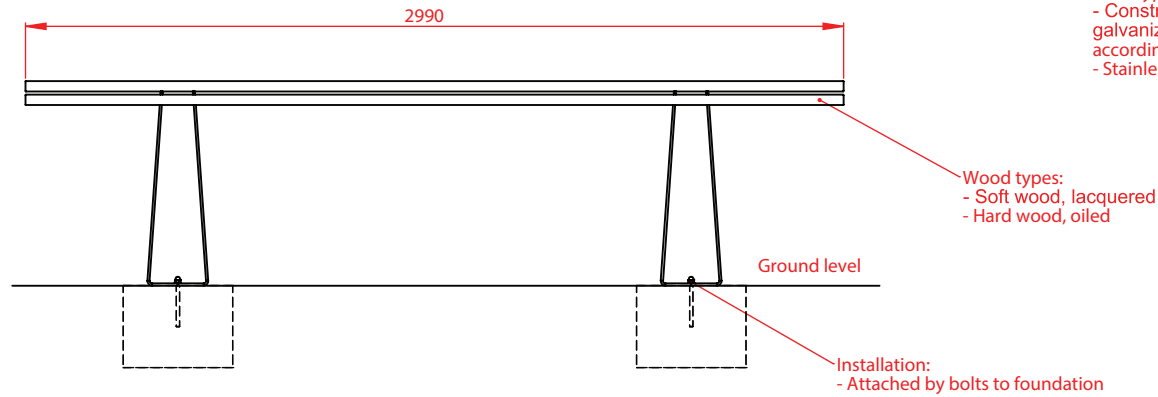

SIDE VIEW

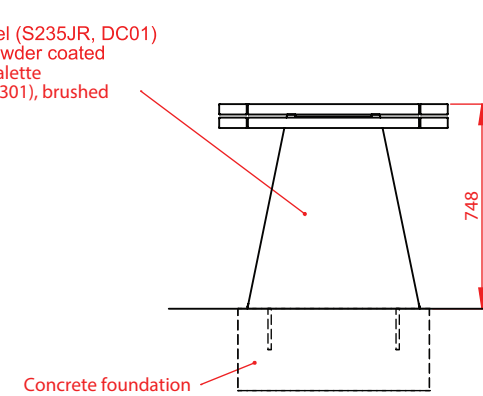

TOP VIEW

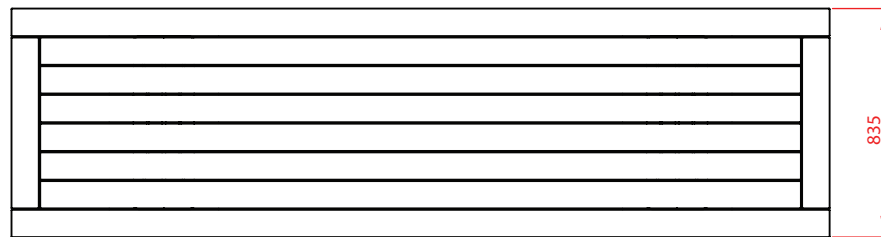

ISOMETRIC VIEW (SCALE 1:30)

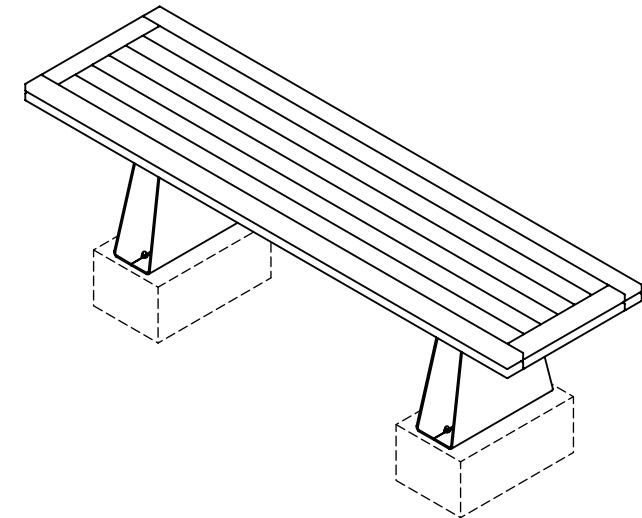

MOUNTING HOLES SPACING

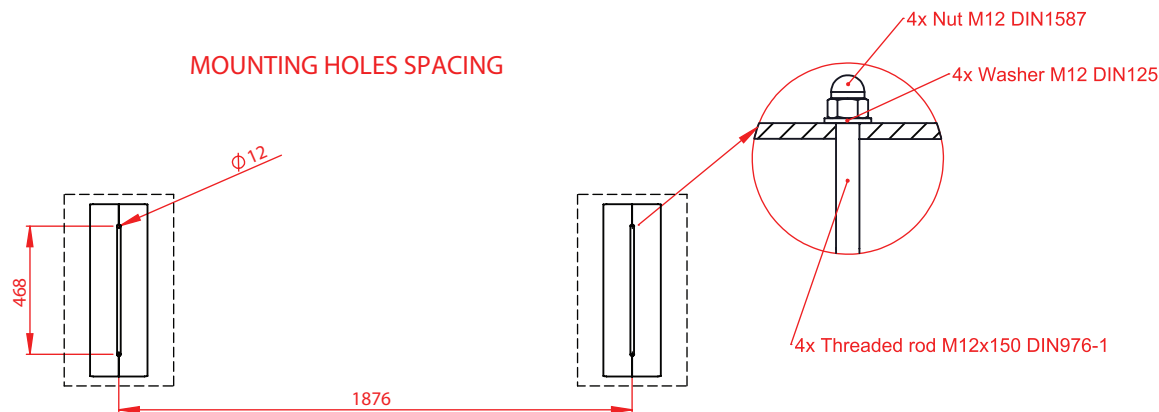

Dimensions given in [mm]

Project and drawing content is intellectual property of ZANO Street Architecture company. The author of the project reserves all rights in accordance with the Directives (EU): 2019/790 of the European Parliament and of the Council of 17 April 2019 on copyright and related rights in the Digital Single Market, Directive 96/9/EC and 2001/29/EC. All rights reserved.



ul.Lindego 7a,
30-148 Kraków

Table
Travetto 13.007

Number:	100419-v1
Sheet:	A4
Scale:	1:25
Mass:	with soft wood 164 kg with hard wood 218 kg