

FRONT VIEW

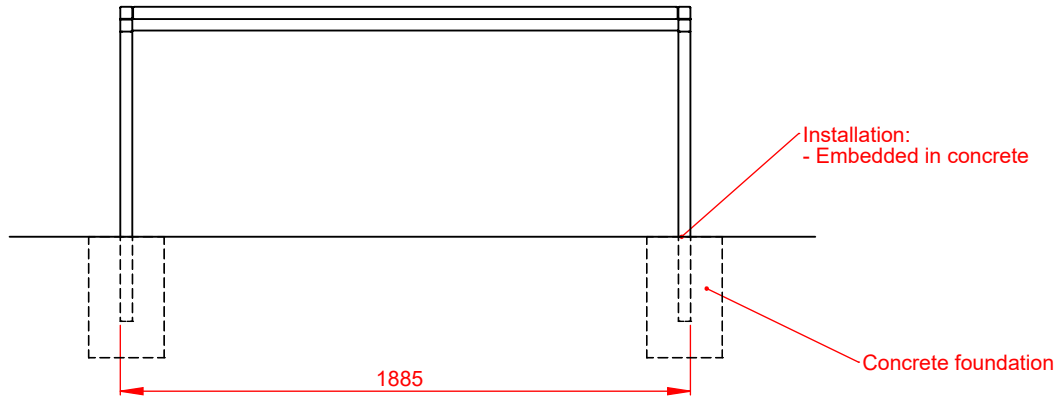

SIDE VIEW

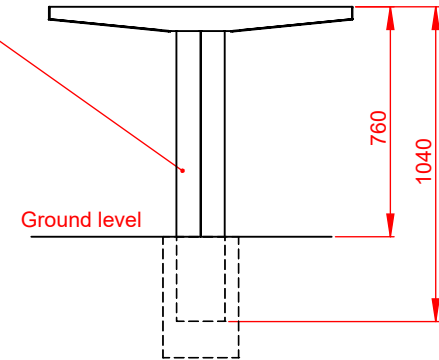

Steel types:
- Construction steel (S235JR, DC01) galvanized and powder coated according to RAL palette
- Stainless steel (1.4301), brushed

TOP VIEW

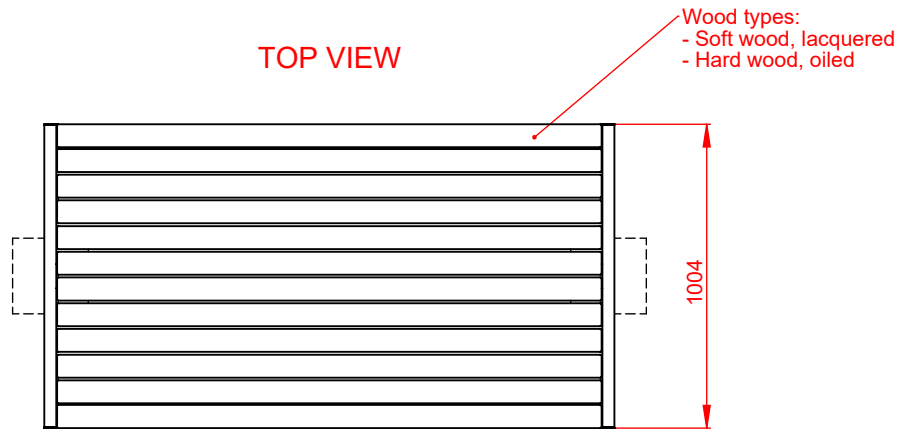

ISOMETRIC VIEW (SCALE 1:25)

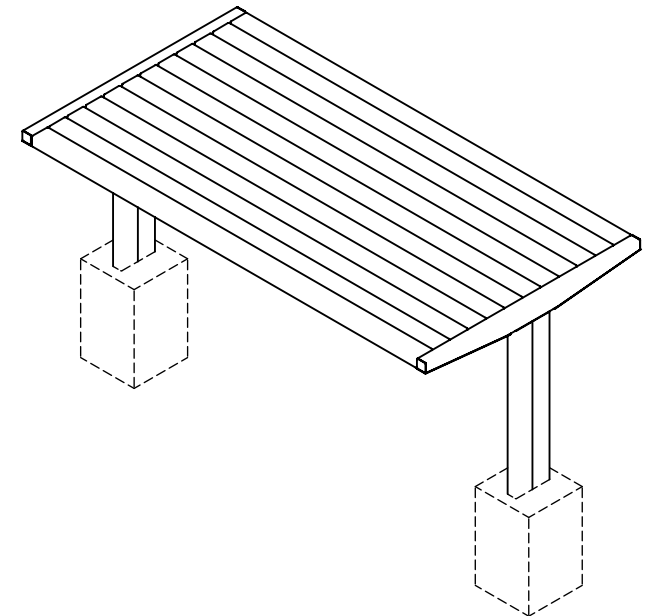

MOUNTING HOLES SPACING (SCALE 1:20)

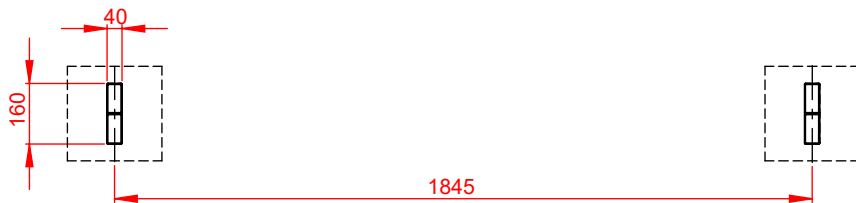

Dimensions given in [mm]

Project and drawing content is intellectual property of ZANO Street Architecture company. The author of the project reserves all rights in accordance with the Directives (EU): 2019/780 of the European Parliament and of the Council of 17 April 2019 on copyright and related rights in the Digital Single Market, Directive 96/9/EC and 2001/29/EC. All rights reserved.

ZANO ul. Lindego 7a,
30-148 Kraków

Number: 300919-v1

Sheet: A4

Scale: 1:25

Mass: with soft wood 55 kg
with hard wood 73 kg

Table
Amicus 13.033

