

GENERAL TECHNICAL DATA

dimensions:

- depth: 100 cm
- height: 76 cm
- width: 188,5 cm

weight: 73 kg

*weight when using exotic wood

materials:

- stainless or construction steel
- domestic coniferous or exotic wood

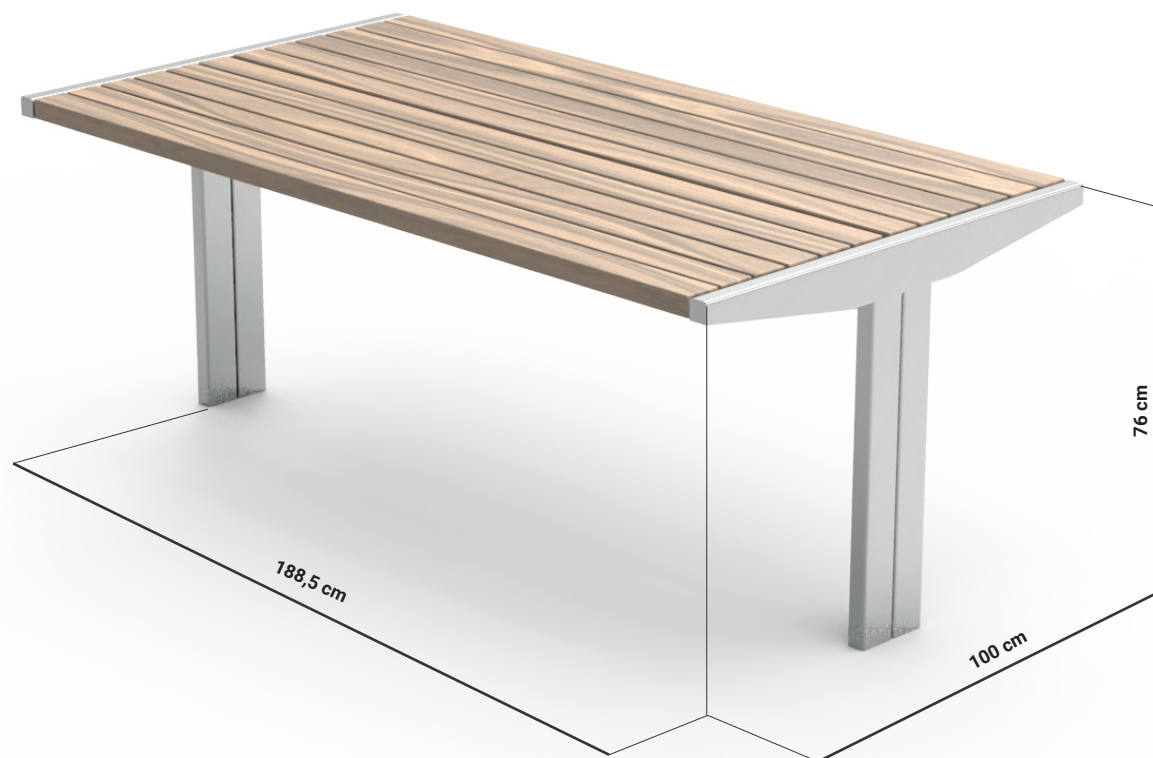

DESCRIPTION

The modern Amicus table contains all the best qualities of the Amicus city furniture family.

Bold style and minimalism characterizing this line makes Amicus an excellent option for futuristic office spaces, museums and galleries with modernist works. Similarly to the Seven bench, from which Amicus originated, the whole structure is based on two steel legs - made of carbon or stainless steel.

The table is available in stainless or carbon galvanized steel and painted in any RAL colour. Wooden top is made of domestic coniferous or exotic wood.



Filip Babiarz

product:
Amicus table 13.033
version:
designer: Filip Babiarz

FRONT VIEW

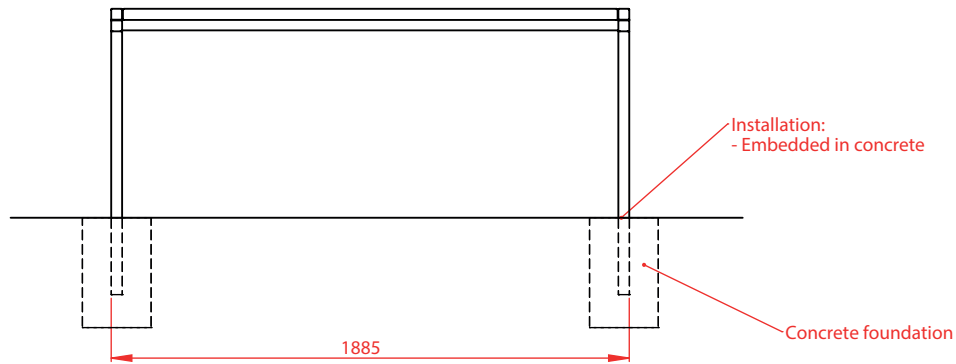

TOP VIEW

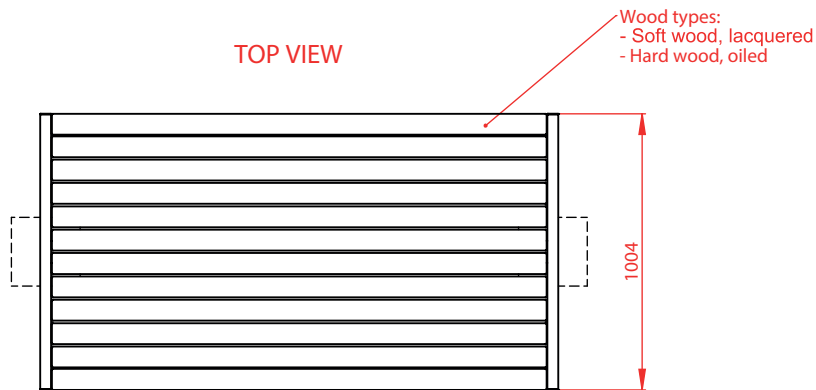

MOUNTING HOLES SPACING (SCALE 1:20)



Steel types:
 - Construction steel (S235JR, DC01) galvanized and powder coated according to RAL palette
 - Stainless steel (1.4301), brushed

SIDE VIEW

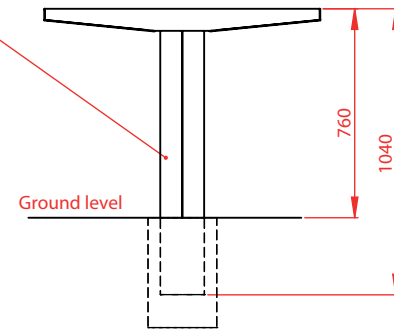

ISOMETRIC VIEW (SCALE 1:25)

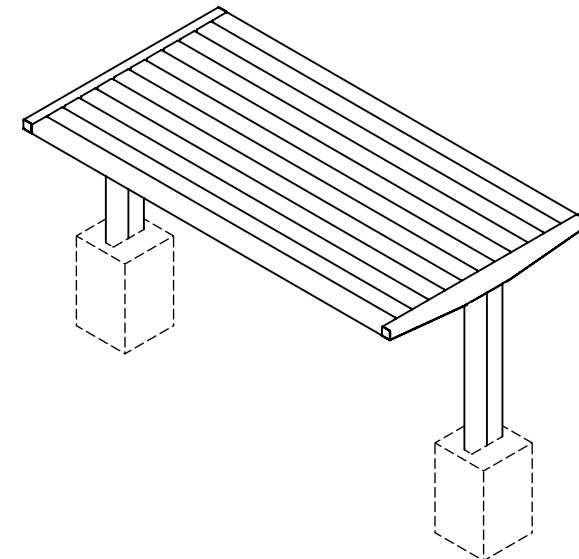

Dimensions given in [mm]

Project and drawing content is intellectual property of ZANO Street Architecture company. The author of the project reserves all rights in accordance with the Directives (EU): 2019/790 of the European Parliament and of the Council of 17 April 2019 on copyright and related rights in the Digital Single Market, Directive 96/9/EC and 2001/29/EC. All rights reserved.



ul.Lindego 7a,
30-148 Kraków

Table
Amicus 13.033

Number:	300919-v1	
Sheet:	A4	
Scale:	1:25	
Mass:	with soft wood	55 kg
	with hard wood	73 kg