

FRONT VIEW

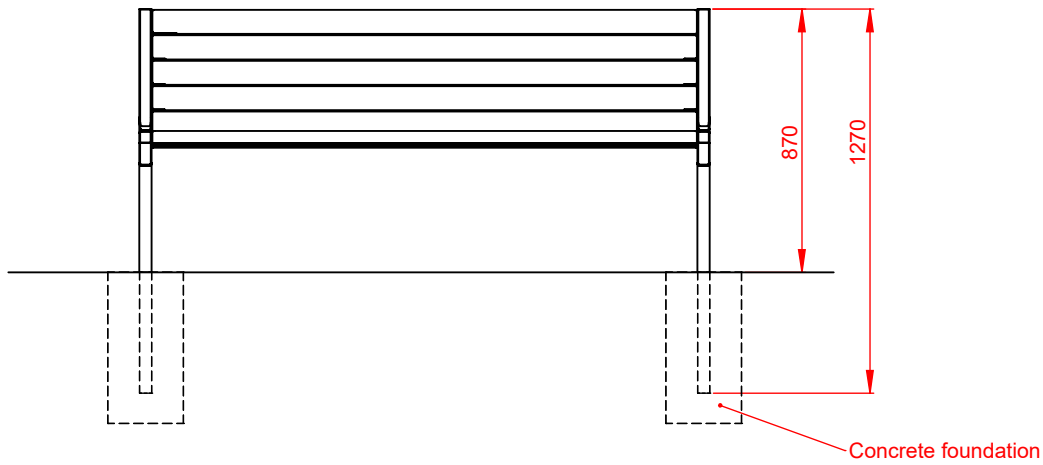

SIDE VIEW

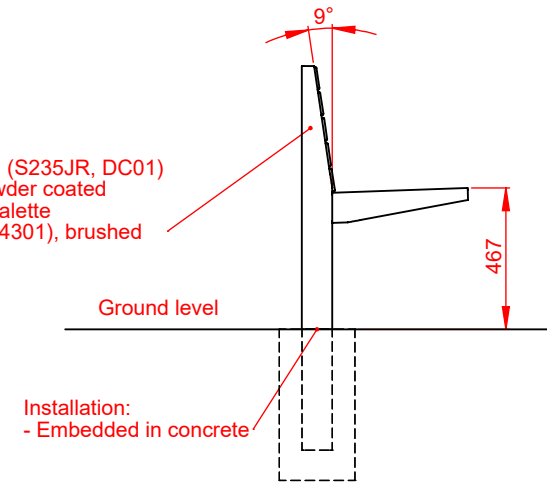

Steel types:
 - Construction steel (S235JR, DC01) galvanized and powder coated according to RAL palette
 - Stainless steel (1.4301), brushed

TOP VIEW

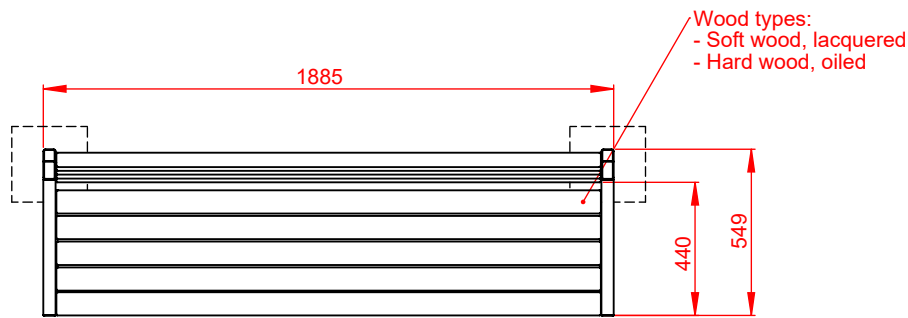

ISOMETRIC VIEW (SCALE 1:25)

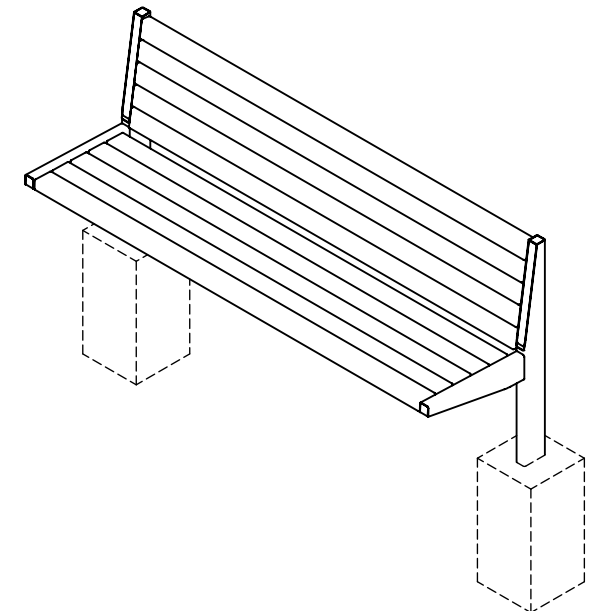

MOUNTING HOLES SPACING (SCALE 1:20)

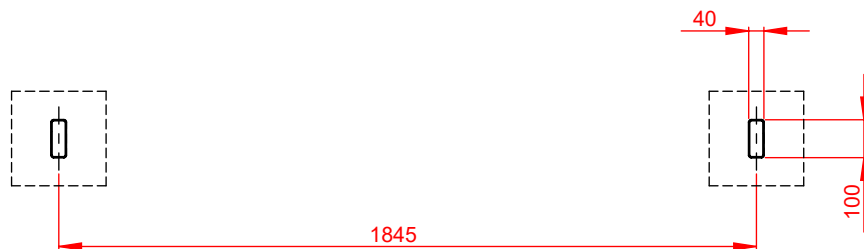

Dimensions given in [mm]

Project and drawing content is intellectual property of ZANO Street Architecture company. The author of the project reserves all rights in accordance with the Directives (EU): 2019/790 of the European Parliament and of the Council of 17 April 2019 on copyright and related rights in the Digital Single Market, Directive 96/9/EC and 2001/29/EC. All rights reserved.

ZANO ul. Lindego 7a,
30-148 Kraków

Bench Amicus 02.033	Number:	080719-v1
	Sheet:	A4
	Scale:	1:25
	Mass:	with soft wood 37 kg with hard wood 59 kg