

Mounting instructions for climbing equipment „collis 190“

Item-No. 51 5511 401



Diagramm 1: Overall view play equipment with description of individual elements

Mounting instructions for climbing equipment „collis 190“

Item-No. 51 5511 401

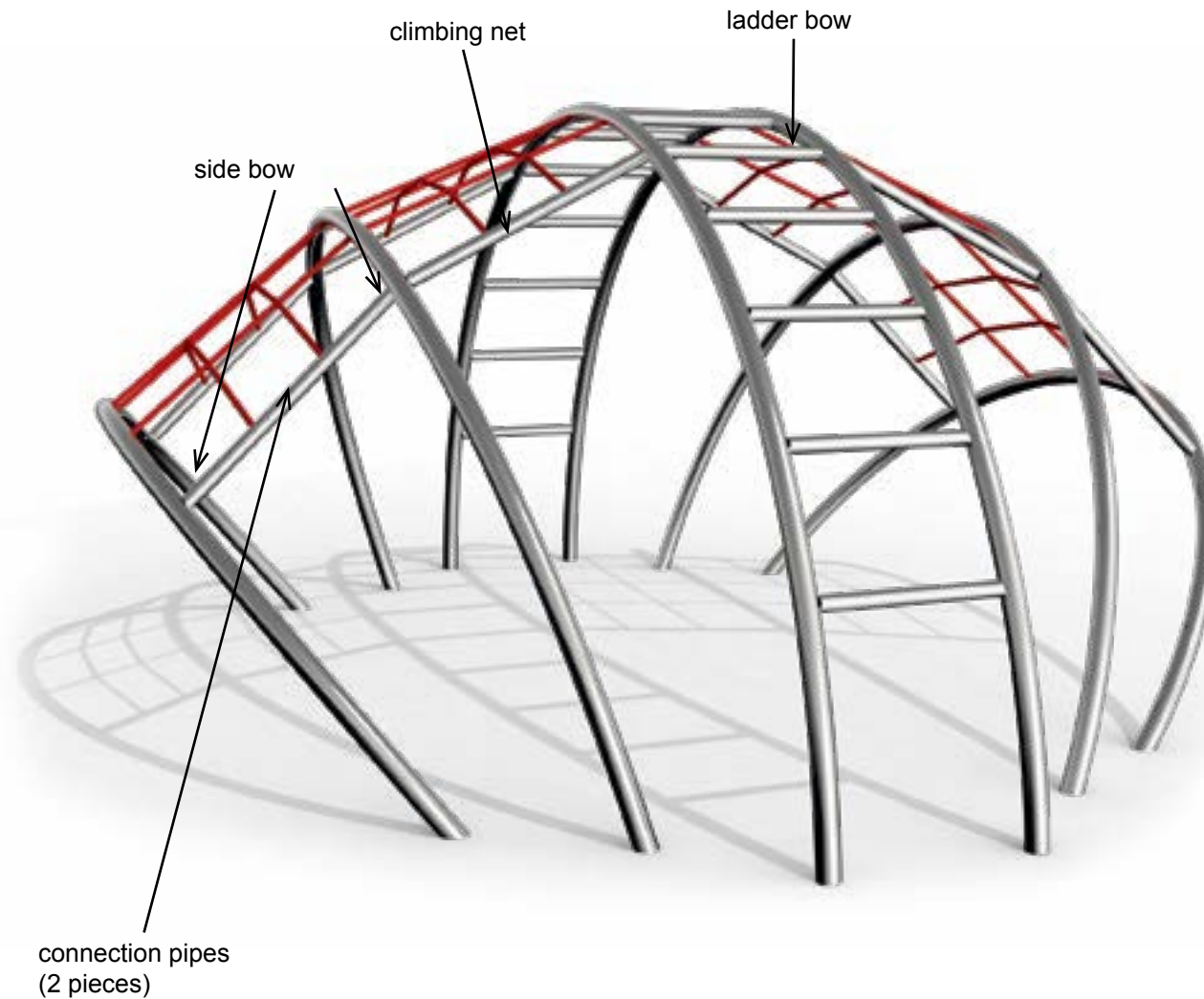

Diagramm 2: Rear view with dimension details „collis“



Diagramm 3a: Top view foundationplan

1. Select the play equipment location in consideration of the required safety area (see Diagram 3: 7600mm x 7300mm).
2. Carry out excavation work for the foundation anchor as shown in Diagram 2 and 3. After excavation, compress the foundation floor.
Note: The climbing equipment is only available with installation depth of 450mm. The climbing equipment is built in on the play level. Pay attention to items marked „game level“ of play equipment!
3. Set up the 2 main concrete foundations (y-form, height 300mm) in the quality class C 20/25 according to the dimensions indicated in diagram 3a and 3b.

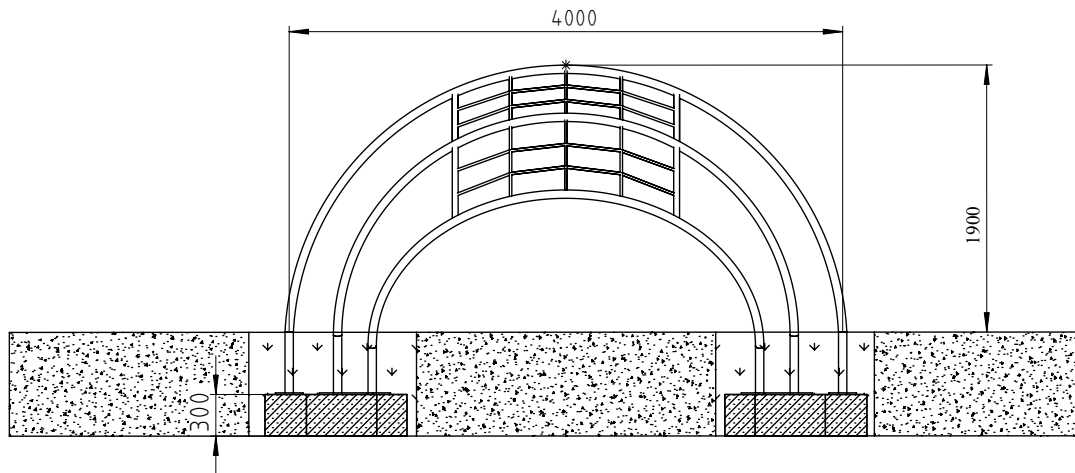
Reinforcement plan:

Concrete foundation with reinforcement

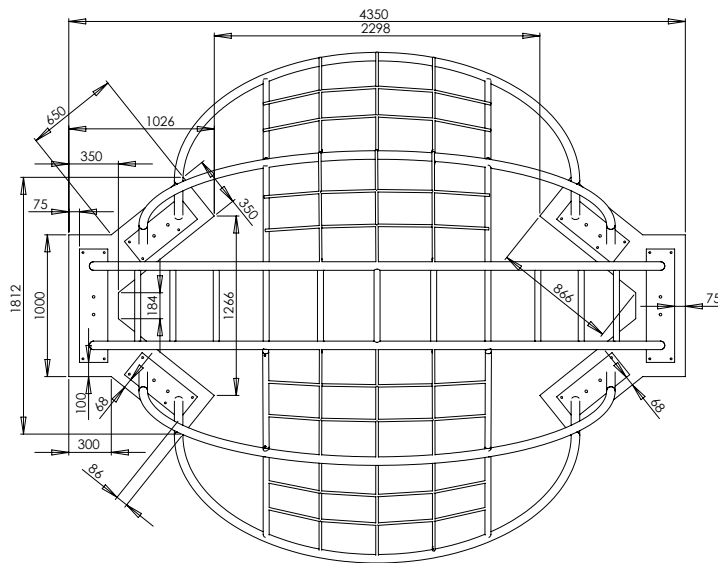
Main foundation: BSt 500S

Ever 4 stirrups \varnothing 8 mm lengthwise and cross

Concrete cover $h' = 3$ cm

Concrete quality class C 20/25

Foundations for attachment parts are no-reinforced

4. After a setting period of 10-14 days, depending on weather conditions and foundation size - clean the surface of the foundations and start with the installation of the combination equipment.

Mounting instructions for climbing equipment „collis 190“

Item-No. 51 5511 401



Diagramm 3b: Rear view foundationplan

5. Place the equipment as shown in the overview and in the Diagram 2a on the main foundation and do a rough aligning.
Note: Do not screw the base plates onto the foundations yet!
6. Arrange the side bow and plug it with the delivered connection pipes at the ladder bow. Screw it with cheese head screws M10 x 25 from below.
7. Add the delivered nets and stretch it with turnings.
8. Adjust the playground equipment at the foundations.
9. Drill holes into all foundations and screw the play equipment into the foundations with the included heavy-duty dowels.

Mounting instructions for climbing equipment „collis 190“

Item-No. 51 5511 401

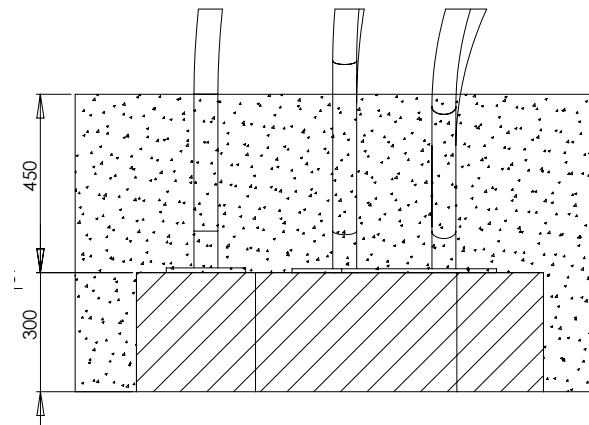
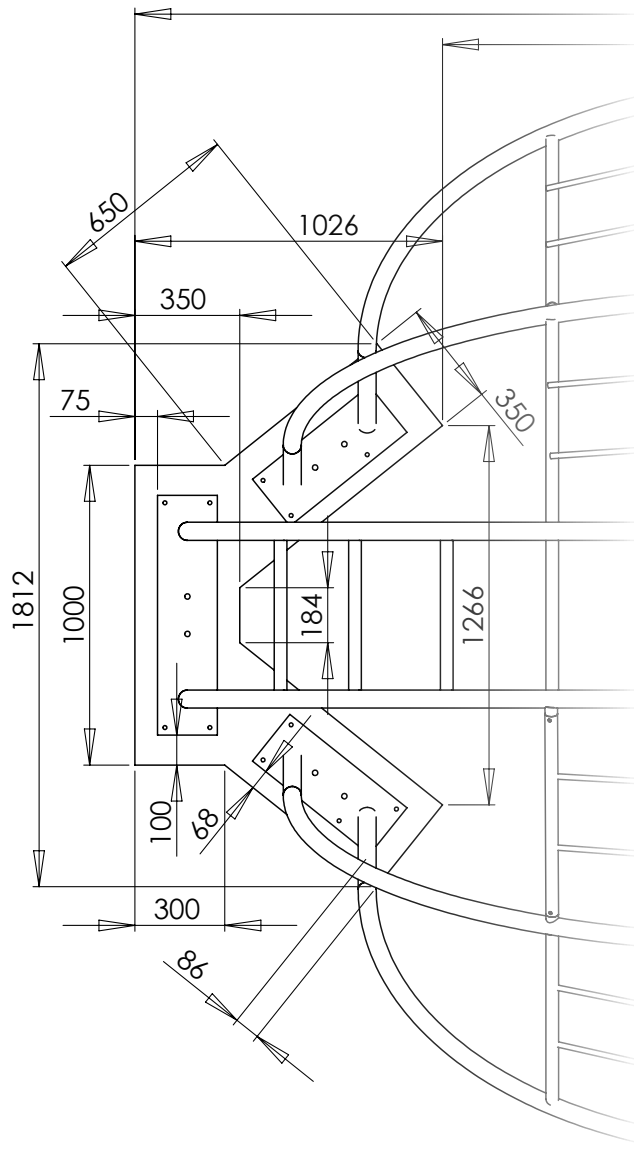

Diagramm 4: Top view dimension details

10. Drill holes into all foundations and screw the play equipment into the foundations with the included heavy-duty dowels.
11. Seal the foundation with the safety cover required for the height of fall indicated.
Critical drop height: 1900 mm.
Recommended surface material: sand, wood chip, gravel, synth. fall protection.
12. After 3 months, check the screws at the joints and retighten them if necessary.
13. Do not allow children to use the equipment before the installation has been finished.

Attention: If the play equipment has been incompletely installed or partly dismantled when carrying out maintenance and repair work, this may lead to particular risks of injury for the user. For this reason, make clearly visible that the equipment shall not be used in such cases.

NOTE: Play equipment, which contain components made of stainless steel should not come with „normal“ steel parts in contact. Those steel parts may rub off and leave small steel particles in combination with moisture brown rust stains. If such corrosion occur on stainless steel parts, they are fine to remove with an abrasive (240 grit).
Please take care when transporting and setting up the fact that the components are made of stainless steel with no „normal“ steel parts in contact.

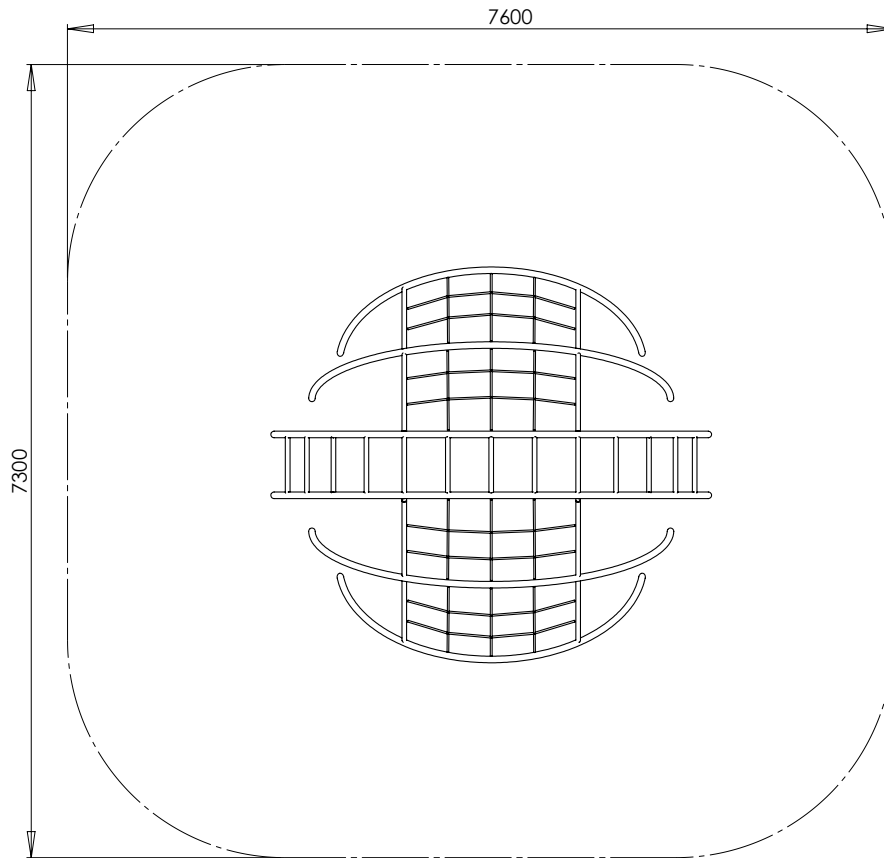
Mounting instructions for climbing equipment „collis 190“

Item-No. 51 5511 401

In order to preserve a good visual appearance of your stilum playground equipment over a long period one should take care of maintenance of the stainless surface even despite of their corrosion resistance.

Especially areas, which can not be reached by rainfall, should be frequently cleaned from dirt and deposits due to air pollution and dirt caused by the atmosphere. Light soiling can easily be removed by using a high pressure cleaner. For persistent deposits use a clean cloth moistened with a special liquid cleaner (e.g. on phosphoric acid) and rinse off with clear water after a short application time.

During cleaning with mild abrasive components, only wipe over stainless steel surface in polishing direction. For heavily soiled surfaces, polishes can be used (e.g. for cleaning chrome on cars) or for greasy and oily dirt alcoholic cleaning agents and solvents (e.g. ethyl alcohol, isopropyl alcohol or acetone).

However, it should be noted that the dissolved soiling is not spread over the surface again. Do not use any chloride or hydrochloric containing cleaning products nor scouring powder, bleaching - or silver polish cleaner. Cleaning intervals depend on type and degree of soiling as well as on demands made on optical characteristics. Therefore cleaning is advisable at intervals of six to twelve months – whereby in the case of strong soiling it is appropriate to clean the playground equipment at intervals of 3 to 6 months.