

Mounting instructions for merry-go-round „circulus 3“

Item No. 51 4013 401

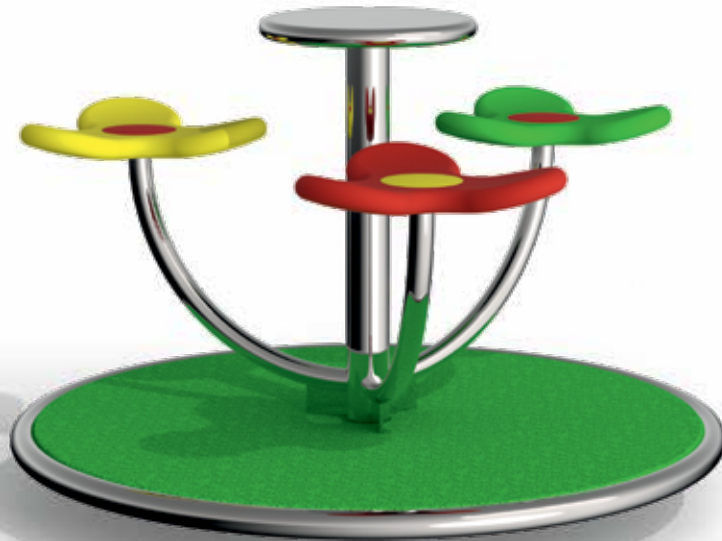
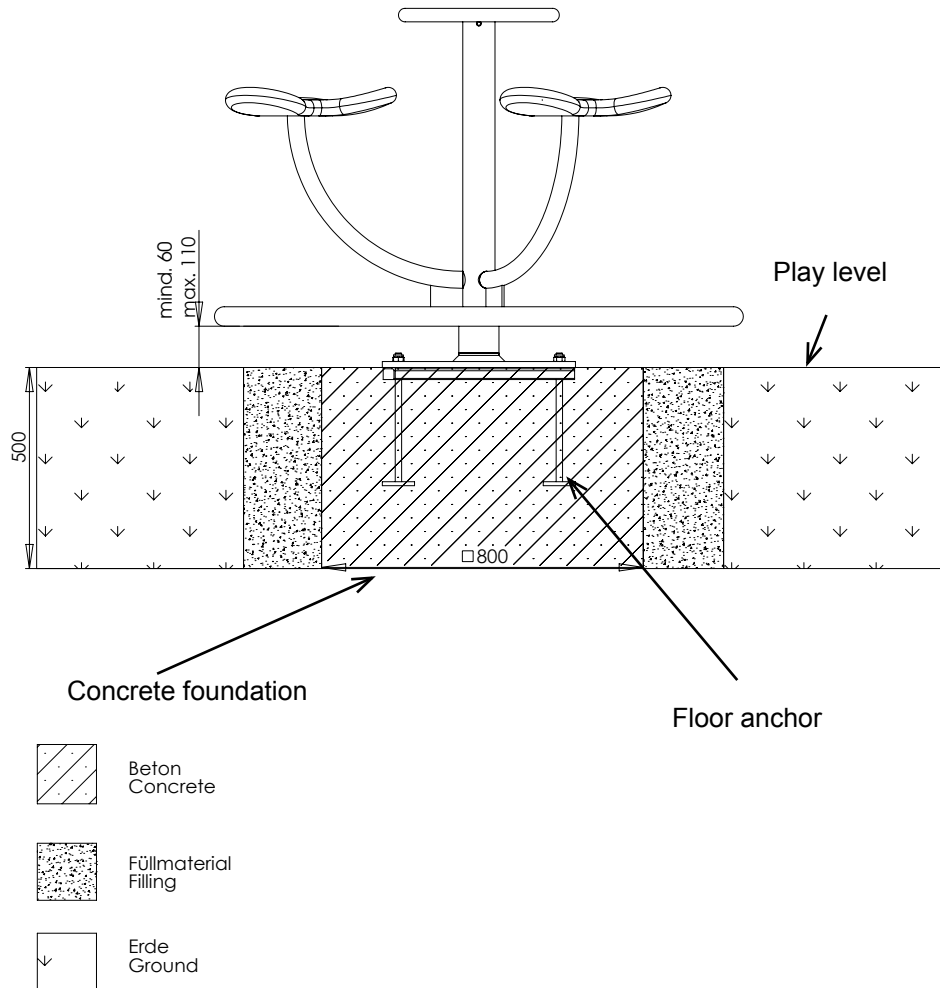

Diagram 1: Overall view of the play equipment

Mounting instructions for merry-go-round „circulus 3“

Item No. 51 4013 401



1. Select the play equipment location in consideration of the required safety area (see Diagram 3: Ø 5400 mm).
2. The impact area of a playground equipment with an enforced movement is not allowed to overlap the impact area of other equipment. Regarding to DIN 1176 - 4.2.8.2.5, impact absorbing surfaces have to be put under the whole impact area of every equipment with an enforced movement.
3. Carry out excavation work for the foundation anchor as shown in Diagram 2. After excavation, compress the foundation floor.
Note: The roundabout is built in on the play level. Pay attention to items marked „game level“ of play equipment!
4. **The distance of the playing surface to the bottom of the hub has to be 60 mm at minimum and a maximum of 110 mm!**
5. Concrete foundation acc. the specified dimensions (LxWxH 800 x 800 x 500mm) build with centrally mounted, horizontal reinforcement. It shed the supplied anchor bolts with the foundation that the upper angle frame is horizontal and flush with the foundation surface.

Reinforcement plan: Concrete foundation with reinforcement

Main foundation: BSt 500S

Ever 4 stirrups Ø 8 mm lengthwise and cross

Concrete cover $h' = 3$ cm

Concrete quality class B25

Diagram 2: Side view with dimension details „circulus3“

Mounting instructions for merry-go-round „circulus 3“

Item No. 51 4013 401

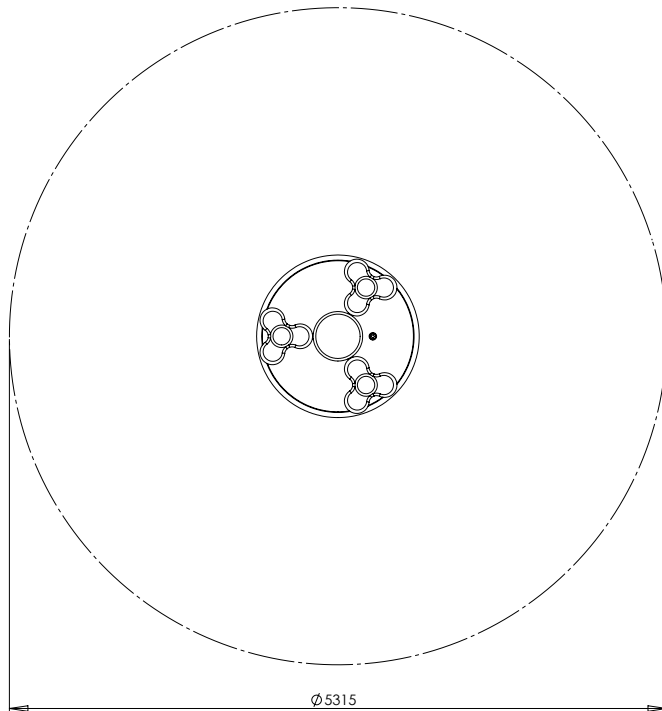

Diagram 3: Top view „circulus3“

6. After a setting period of 10 – 14 days, depending on weather conditions and foundation size, any existing gaps between the foundation and Foundation hole with compacted fill and excavation.
7. Clean the surface of the foundation and put the pre-mounted play equipment onto the foundation anchor. Screw out the locking screw with hexagon socket from the roundabout bottom. Use the opening in the roundabout floor to screw the base plate of the play equipment onto the foundation anchor. After that, close the opening in the roundabout bottom.
8. Fill up and compress the holes between the foundation and the foundation hole with the excavation.
9. Seal the foundation with the safety cover required for the height of fall indicated. Set up impact-absorbing playground surfacing according to EN 1177 HIC 1000.
Critical drop height: 660 mm
Recommended surface material: grass, sand, wood chip, gravel, synth. fall protection.
10. Do not allow children to use the equipment before the installation has been finished.

Attention: If the play equipment has been incompletely installed or partly dismantled when carrying out maintenance and repair work, this may lead to particular risks of injury for the user. For this reason, make clearly visible that the

Mounting instructions for merry-go-round „circulus 3“

Item No. 51 4013 401

equipment shall not be used in such cases.

NOTE: Play equipment, which contain components made of stainless steel should not come with „normal“ steel parts in contact. Those steel parts may rub off and leave small steel particles in combination with moisture brown rust stains. If such corrosion occur on stainless steel parts, they are fine with an abrasive (240 grit) to remove.

Please take care when transporting and setting up the fact that the components are made of stainless steel with no „normal“ steel parts in contact. In order to preserve a good visual appearance of your stilum playground equipment over a long period one should take care of maintenance of the stainless surface even despite of their corrosion resistance.

Especially areas, which can not be reached by rainfall should be frequently cleaned from dirt and deposits due to air pollution and dirt caused by the atmosphere. Light soiling can easily be removed by using a high pressure cleaner.

For persistent deposits use a clean cloth moistened with a special liquid cleaner (e.g. on phosphoric acid) and rinse off with clear water after a short application time. During cleaning with mild abrasive components, only wipe over stainless steel surface in polishing direction.

For heavily soiled surfaces, polishes can be used (e.g. for cleaning chrome on cars) or for greasy and oily dirt alcoholic cleaning agents and solvents (e.g. ethyl alcohol, isopropyl alcohol or acetone).

However, it should be noted that the dissolved soiling is not spread over the surface again.

Do not use any chlorid or hydrochloric containing cleaning products nor scouring powder, bleaching - or silver polish cleaner. Cleaning intervals depend on type and degree of soiling as well as on demands made on optical characteristics.

Therefore cleaning is advisable at intervals of six to twelve months – whereby in the case of strong soiling it is appropriate to clean the playground equipment at intervals of 3 to six months.