

DATA SHEET SPRINGRIDER KLEMENS

Text for invitation to tender | Item No: 513019401

MATERIALS | SCOPE OF SUPPLY

Springrider, pre-mounted completely

body:	EPDM rubber granule with steel inlay
handle:	stainless steel, V2A, 2 pieces with balls made of EPDM, 2 pieces
spring:	spring steel \varnothing 20 mm \varnothing 200 x 200 mm height 1 piece
eyes:	plastic, 2 pieces
foundation anchor:	galvanized steel

TECHNICAL INFORMATION

Dimensions:

Main dimension:	645x 520 mm
Height:	830 mm
Weight:	50 kg
capacity:	acc. to normative requirements
Dimension largest piece:	645 x 520 x 1326 mm
Heaviest piece:	50 kg

Max. fall height:	500 mm
Safety surfacing area:	6,16 m ²
Required safety slabs:	9,00 m ²
Required lawn grating:	9,00 m ²
Recommended surface material:	grass, sand, wood chip, gravel, synth. impact protection

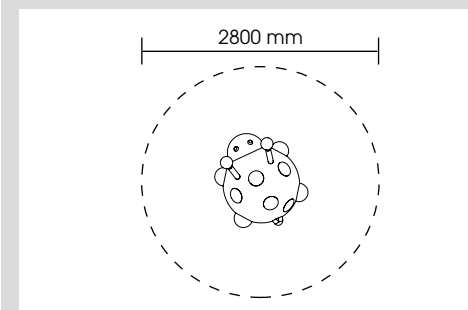

INSTALLATION

Foundations: 1
Installation at concrete surfaces possible (special edition)

Installation according to our detailed mounting instructions, see www.stilum.com

