

DATA SHEET MULTIFUNCTIONAL TRAINER

Item No: 551010402 | Text for invitation to tender

MATERIALS | SCOPE OF SUPPLY

Fitness equipment, nearly pre-mounted;
final installation on location

tubular frame:	stainless steel, V2A
tube end caps:	balls made of EPDM, 20 pieces
roll:	stainless steel, V2A, with layer made of EPDM rubber granule, 1 piece
foundation:	steel, coated
Instruction sheet:	stainless steel, aludibond 1 piece

TECHNICAL INFORMATION

Dimensions:

Main dimension:	3820 x 1160 mm
Height:	2000 mm
Weight:	265 kg
capacity:	acc. to normative requirements

Max. fall height:	2000 mm
Safety surfacing area:	34,25 m ²
Required safety slabs:	37,50 m ²
Required lawn grating:	40,00 m ²
Recommended surface material:	sand, gravel, wood chip, synth. impact protection

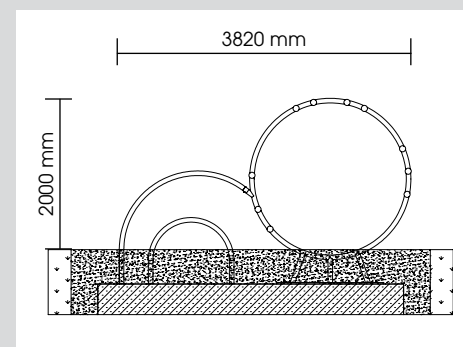
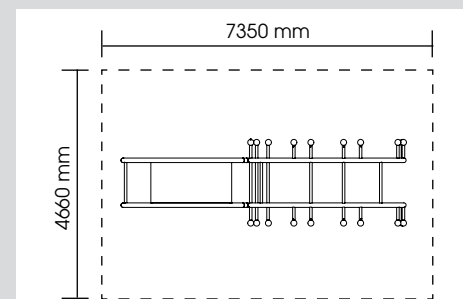

INSTALLATION

Foundations: 1
Installation at concrete surfaces possible
(special edition)

Installation according to our detailed mounting
instructions, see www.stilum.com

