



PL	INSTRUKCJA MONTAŻU	Nazwa	Baszta 11	Nr kat.	1111
ENG	ASSEMBLY INSTRUCTIONS	Product	Tower 1111	Cat. no.	
DEU	MONTAGEANLEITUNG	Name	Orbis Turm 1111 / Metall- Pfosten	Art.-Nr.	

## 1111



Wiek użytkowników Age of users Altersgruppe	Ilość użytkowników Number of users Anzahl der Benutzer	Przeznaczenie urządzenia Purpose of device Bestimmung des Spielgerätes	Zgodność z normą In accordance with the standard Geltende Norm
3-14	18	do zabawy na zewnątrz for outdoor playing zum draußen Spielen	PN-EN 1176-1+A1:2024-03
NOVUM Sp. z o.o. ul. Gnieźnieńska 2a, 12-100 Szczytno		e-mail: kontakt@novum4kids.pl e-mail: export@novum4kids.com	www.novum4kids.pl www.novum4kids.com

**UWAGA / WARNING / ACHTUNG:**

**PL** Jeżeli w zestawie występuje zjeżdżalnia, zestaw należy posadzić w taki sposób, aby ślizg zjeżdżałni znajdował się od strony północnej, czyli od strony nienasłonecznionej, aby zapobiegać nadmiernemu nagrzewaniu się ślizgu.

**ENG** If there is a slide in the set, it should be installed from the north, poorly sunny side to avoid possible hazards (burns) through direct skin contact.

**DEU** Wenn eine Spielplatzanlage eine Rutsche enthält, sollte diese Anlage so platziert werden, dass die Rutsche sich auf der Nordseite befindet, dh. auf der schattigen Seite, um übermäßige Erwärmung der Rutschbahn zu vermeiden.

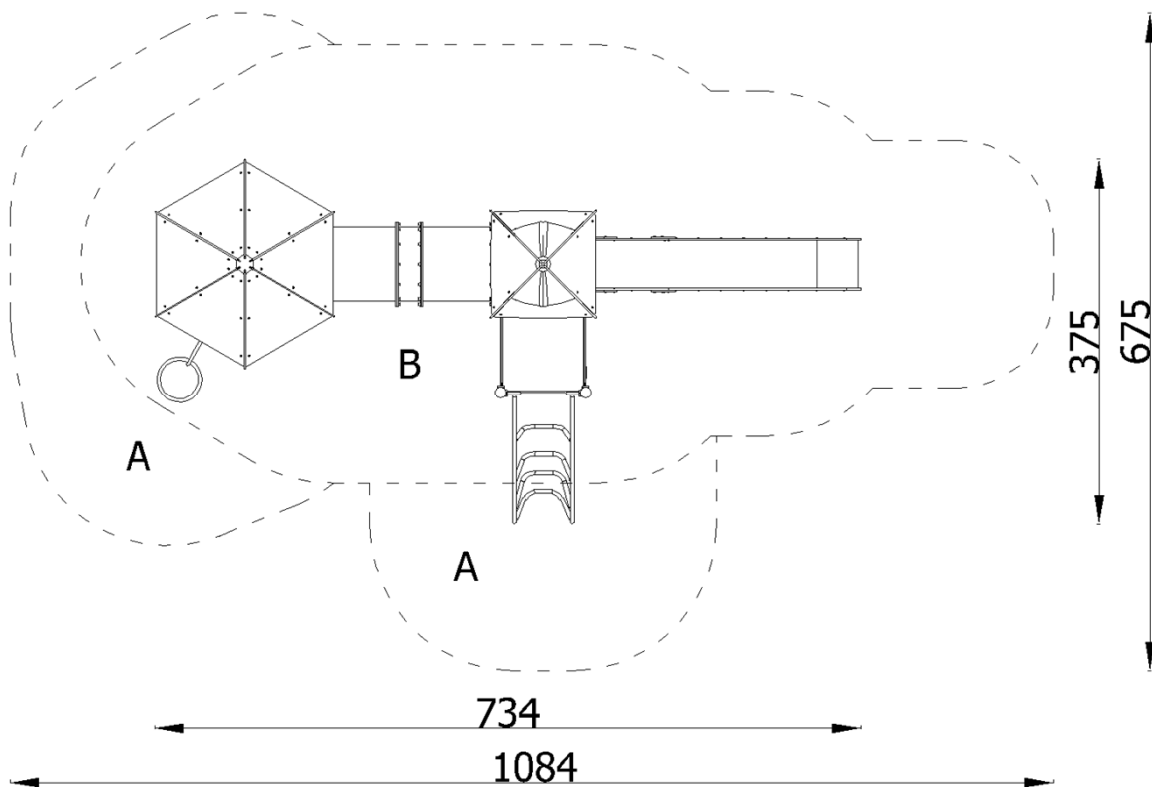

Montaż zgodnie z planem zagospodarowania terenu.  
 Installation in accordance with the land development plan.  
 Montage gemäß dem Flächennutzungsplan

Bezpieczna nawierzchnia / Safe surface / Safe Oberfläche

Strefa Zone Zone	Max. wysokość upadku Max. fall height Max. Fallhöhe	Pole powierzchni Surface area Fläche	Obwód strefy bezpiecz. Perimeter security zone Umkreis der Fallschutzfläche
A	1,50 m	13,00 m <sup>2</sup>	31,50 m
B	1,80 m	36,00 m <sup>2</sup>	
C	-	-	

Nawierzchnia / Safe surface / Fallschutzbelag			1111
	Materiał Material Material	Min. wysokość warstwy Min. layer thicknesses Min. Schichtöhe	
$h < 0,6$ m	Beton / Concrete / Beton Nawierzchnia bitumiczna / Bituminous surfacing / Bituminöse Oberfläche		
$h \leq 1$ m	Gleba / Topsoil / Boden Darrí / Turf / Grasnarbe		
$h \leq 2$ m	Kora / Bark / Borke	20÷80 mm	300
	Wióry / Wood chips / Holzhackschnitzel	5÷30 mm	
	Piasek / Sand / Sand Żwir / Gravel / Kies	0,25÷8 mm	
$h \leq 3$ m	Kora / Bark / Borke	20÷80 mm	400
	Wióry / Wood chips / Holzhackschnitzel	5÷30 mm	
	Piasek / Sand / Sand Żwir / Gravel / Kies	0,25÷8 mm	
$h \leq 3$ m	Nawierzchnia syntetyczna / Synthetic granulates / Synthetische Oberfläche	wg danych producenta acc. to the manufacturer's data nach Angaben des Herstellers	

Posadowienie / Foundation / Gründung	1111
--------------------------------------	------

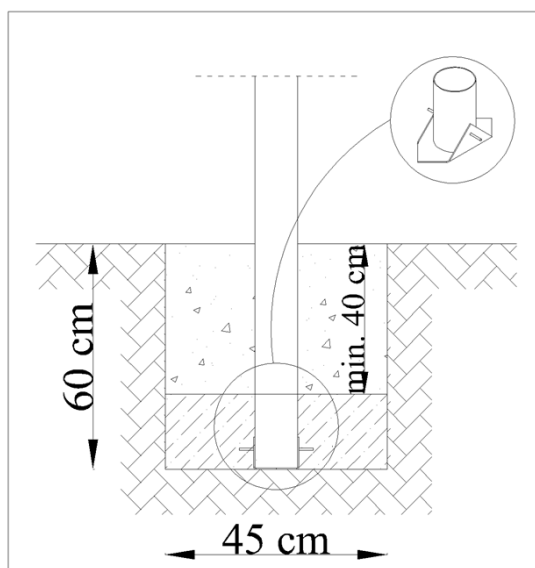

Beton / Concrete / Beton: **C16/20** - **0,64** m<sup>3</sup>

W celu kontroli fundamentów należy usunąć nawierzchnię bezpieczną / piasek / żwir etc.  
 In order to control the foundations, remove the safe surface (sand, gravel, etc.)  
 Um die Fundamente zu überprüfen, entfernen Sie den Fallschutzbelag: Sand/ Kies etc.

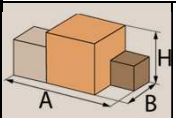
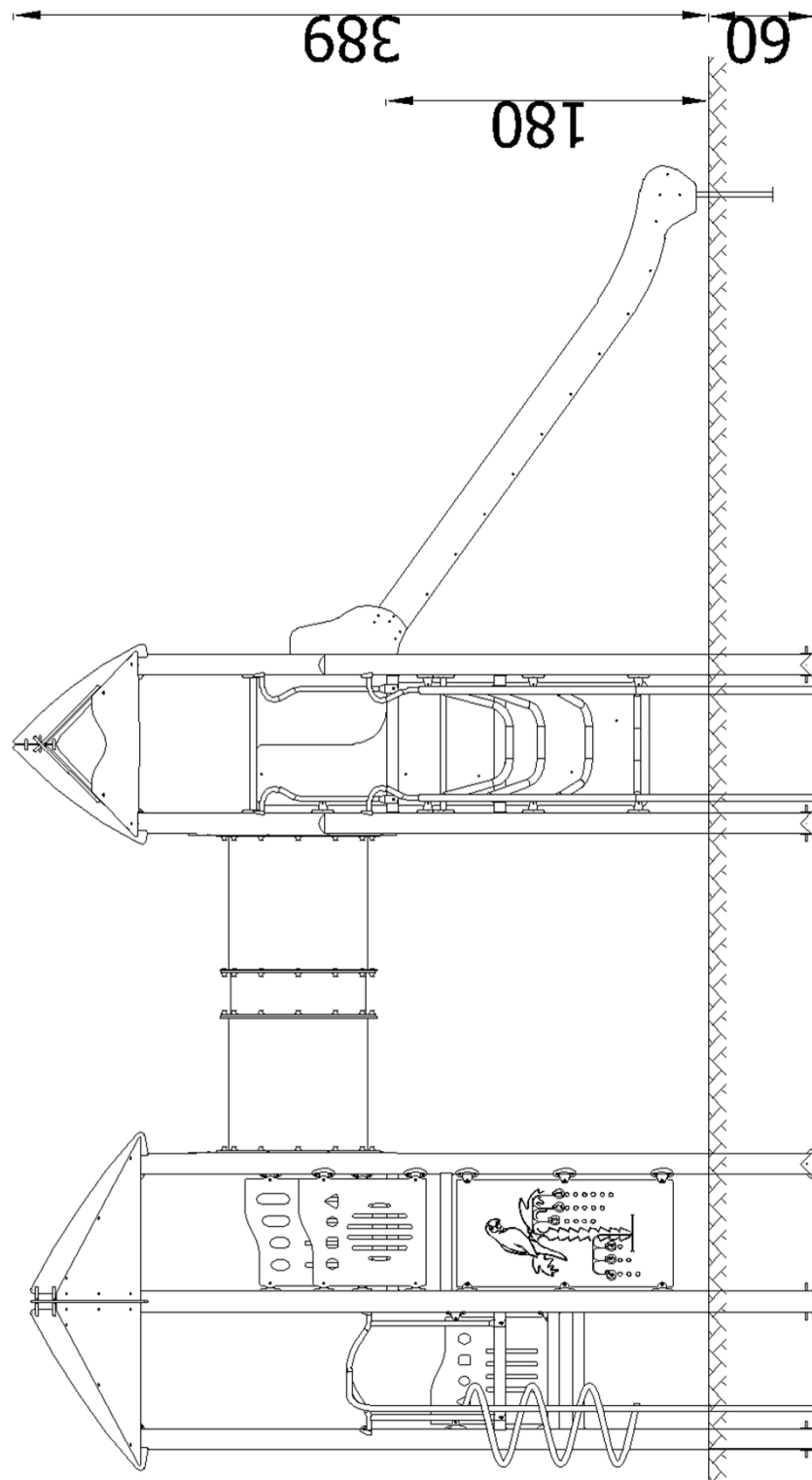

3,75x7,34x3,89  
(AxBxH) [m]

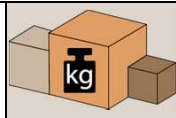

519 kg

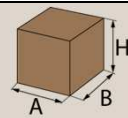

3,8x0,12x0,12  
(AxBxH) [m]



69 kg



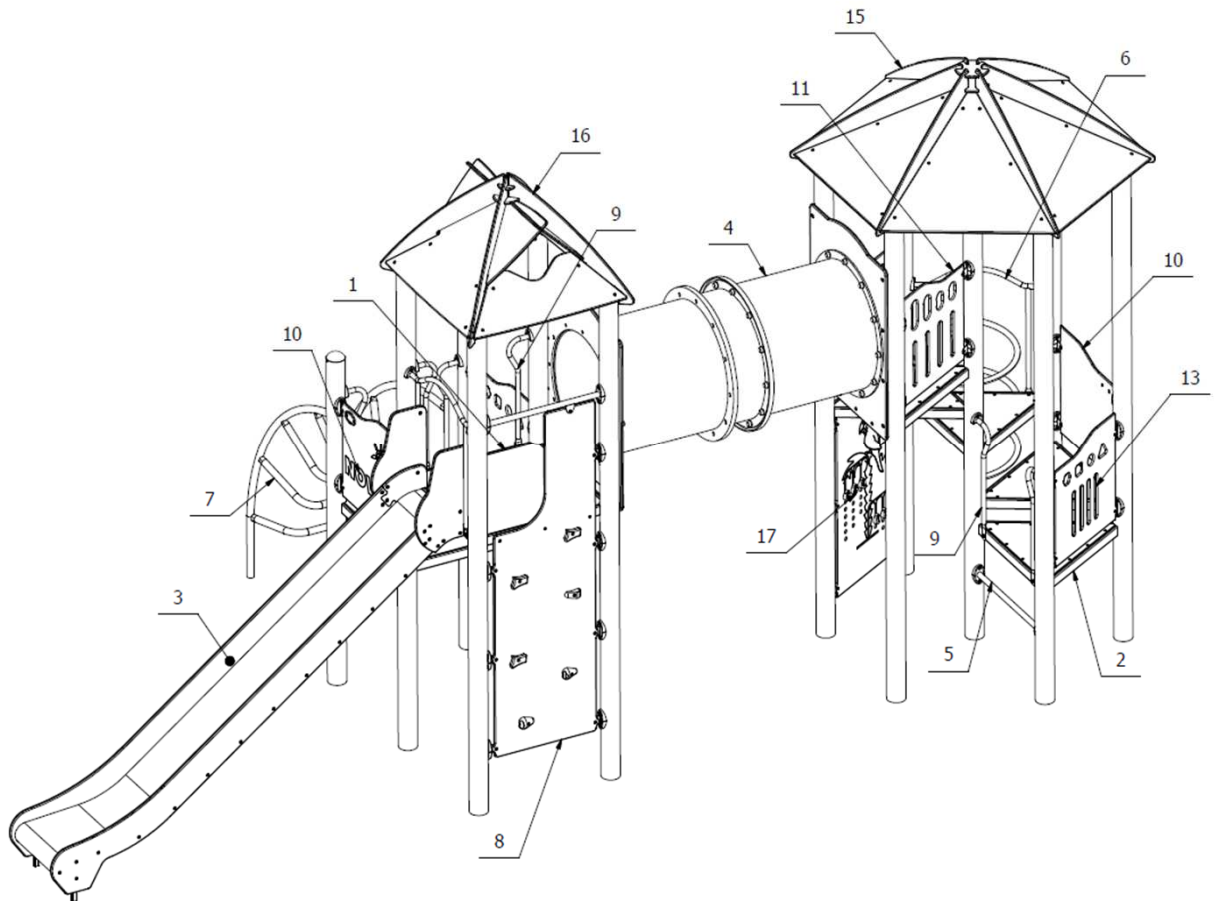





Części zamienne dostępne u producenta.  
Stosować klej do gwintów w połączeniach śrubowych.

Spare parts available from the manufacturer.  
Use thread glue in screw connections.

Ersatzteile beim Hersteller erhältlich.  
Gewindekleber für Schraubverbindungen verwenden.

18	1111/1 - 1111/12	1
17	26194_RM	1
16	2518_RM	1
15	2516_RM	1
14	2403_28_RM_P	1
13	2403_27_RM_P	1
12	2403_26_RM_L	1
11	2403_18_RM_P	1
10	2403_01_RM_P	2
9	23108_RM	2
8	23106_RM	1
7	23104_RM	1
6	23103_RM	1
5	2335_RM	2
4	2207_RM	1
3	2115_RM	1
2	2072_RM	5
1	2070_RM	2
Lp.	Nr części	Ilość
No.	Art. Nr.	Quantity Anzahl
	Part No.	Teile-Nr

															
								5 m	30 m						
															
2,5 m				60 cm	100 cm										
															
				7 mm								13 mm	17 mm	19 mm	24 mm
															
13 mm	17 mm	19 mm	24 mm	4 mm	5 mm	6 mm	8 mm	T40				T45			
															

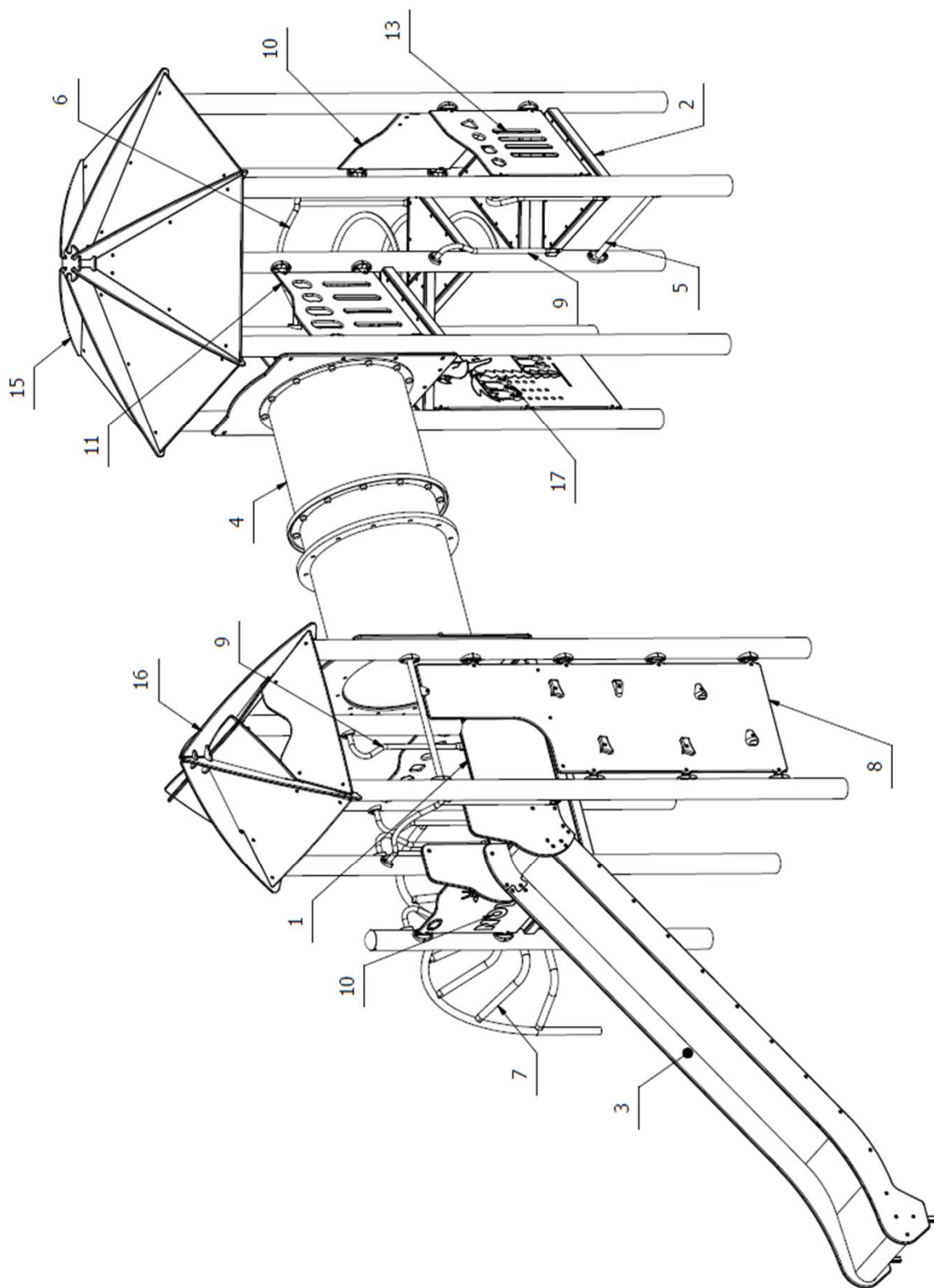

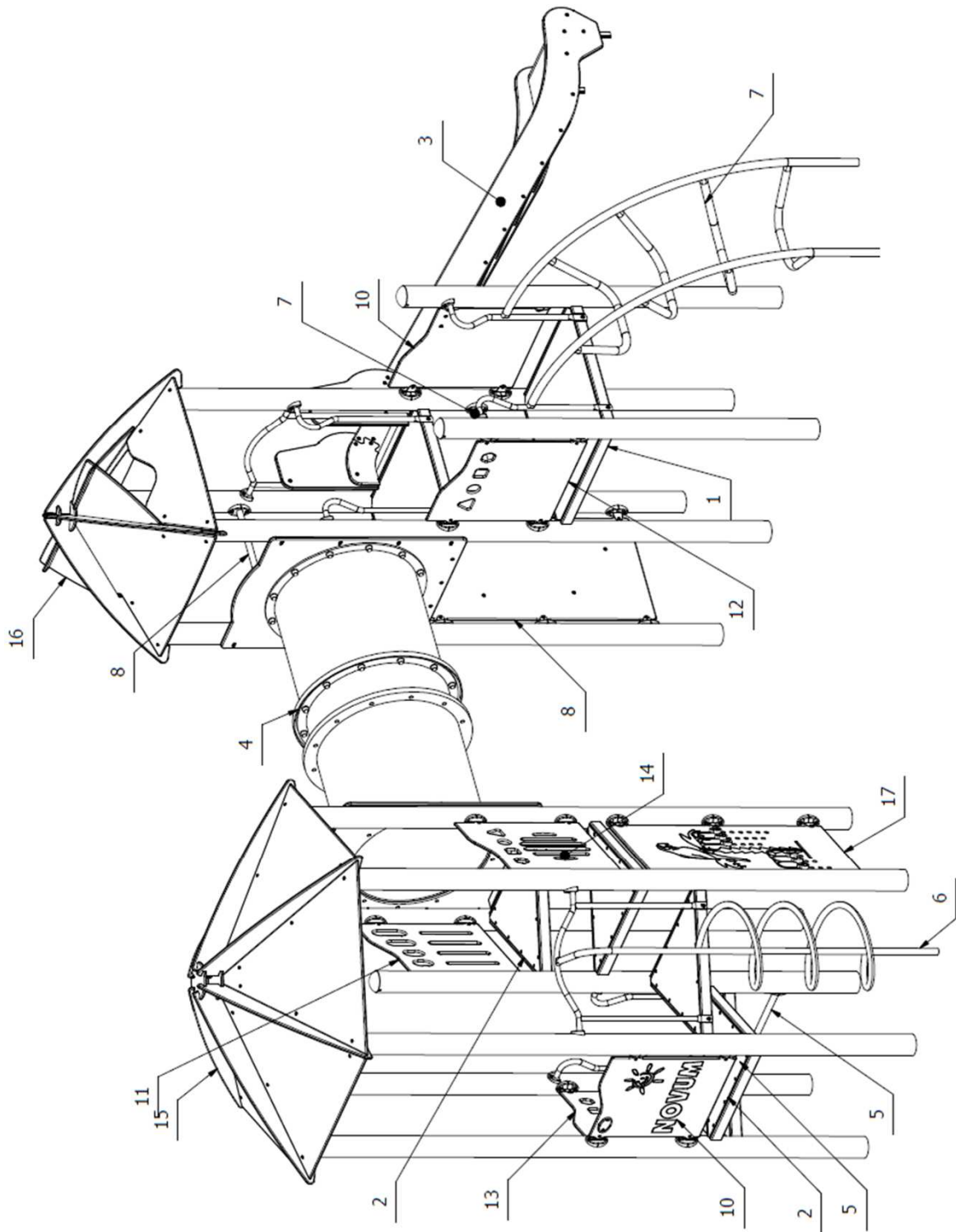

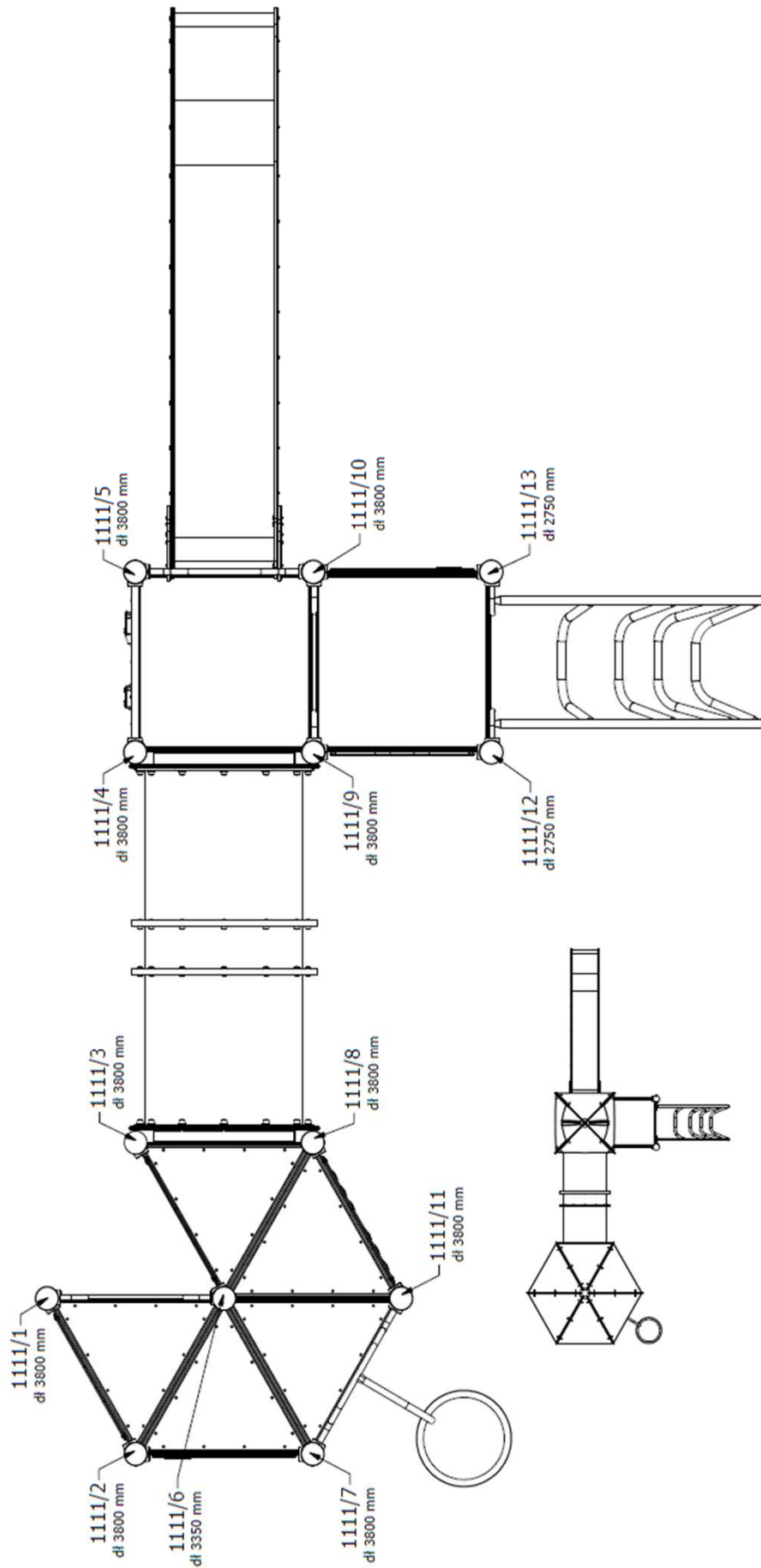

ISO7380_2_M8x16_A2	8
Drawing/Norm number	Quantity

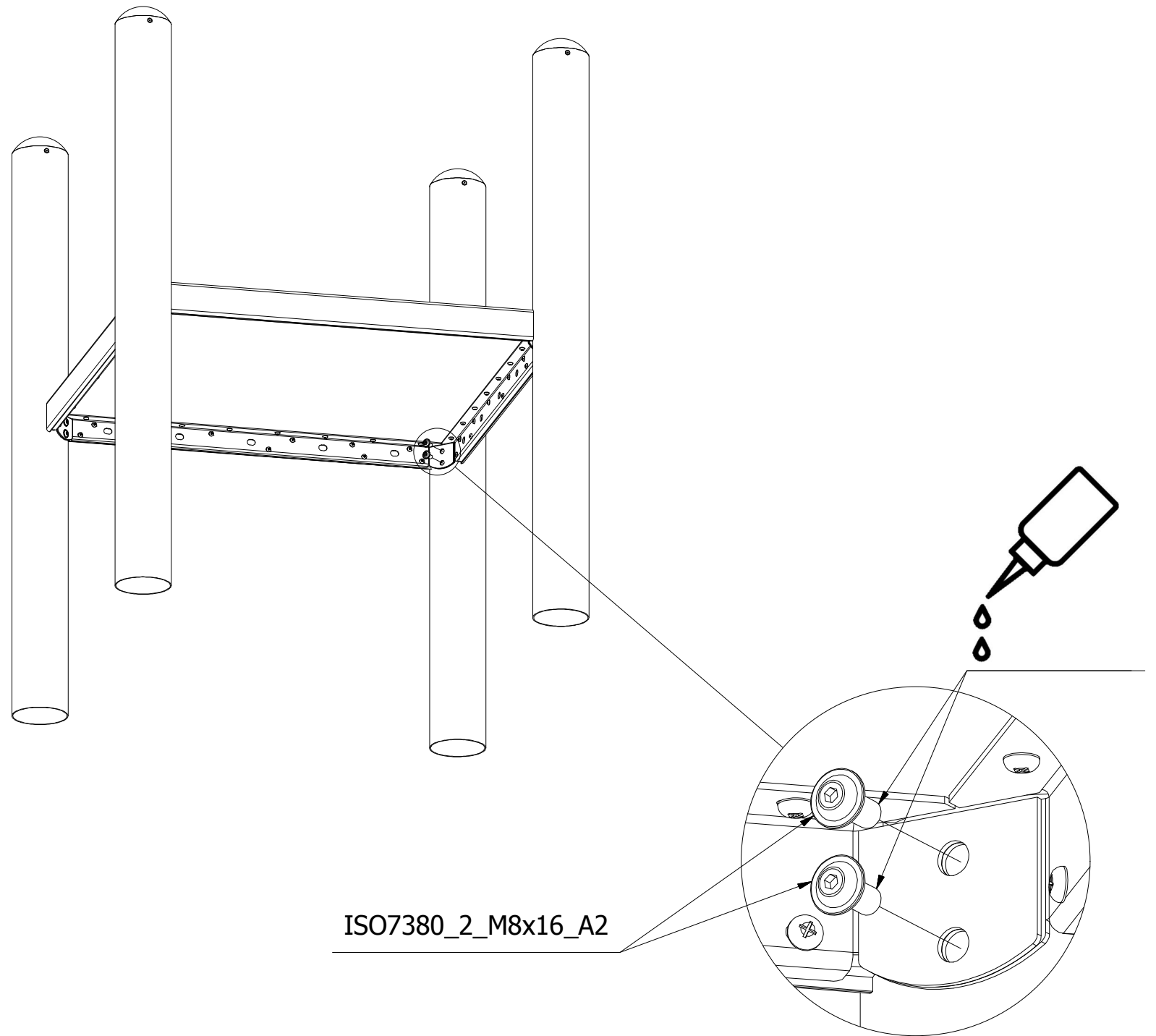
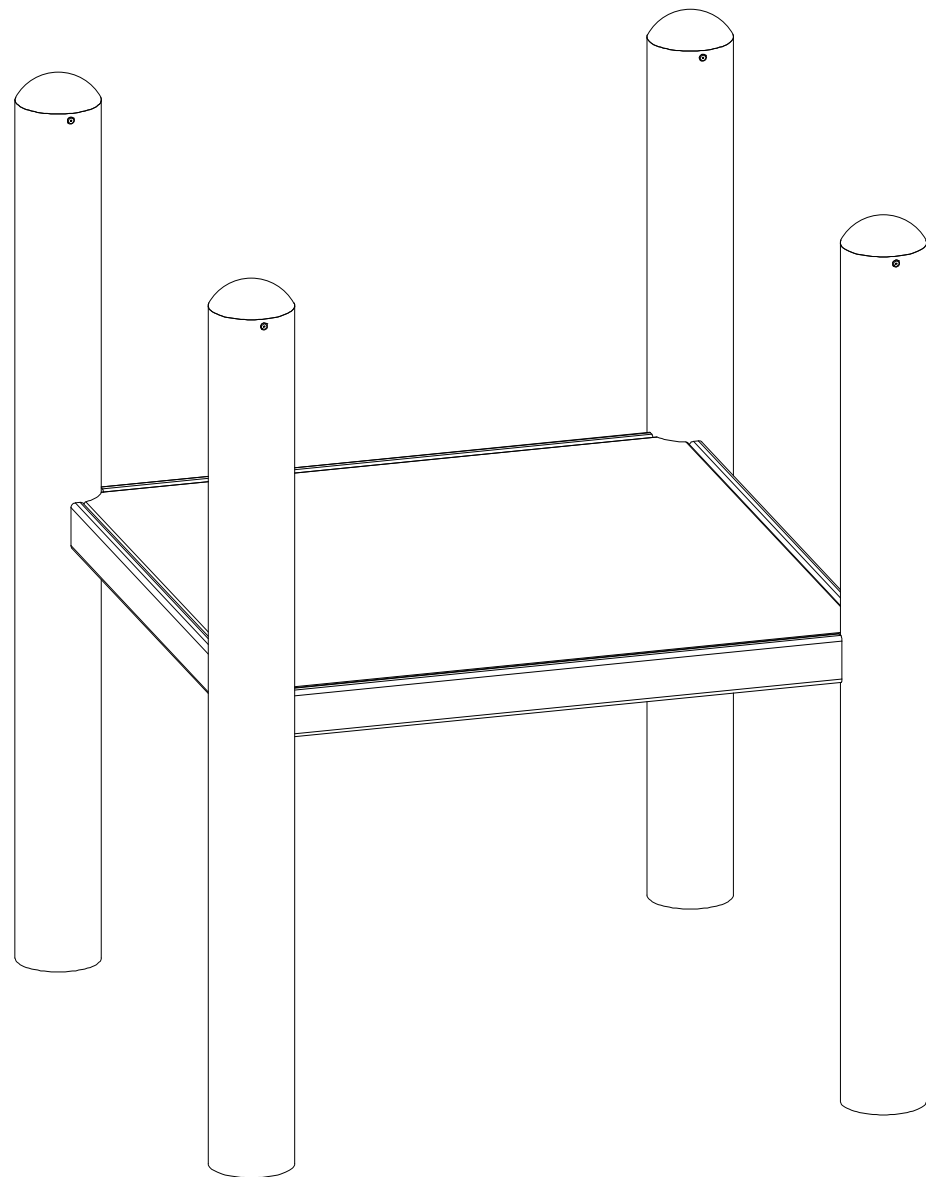

ISO7380_2_M8x16_A2	6
Drawing/Norm number	Quantity

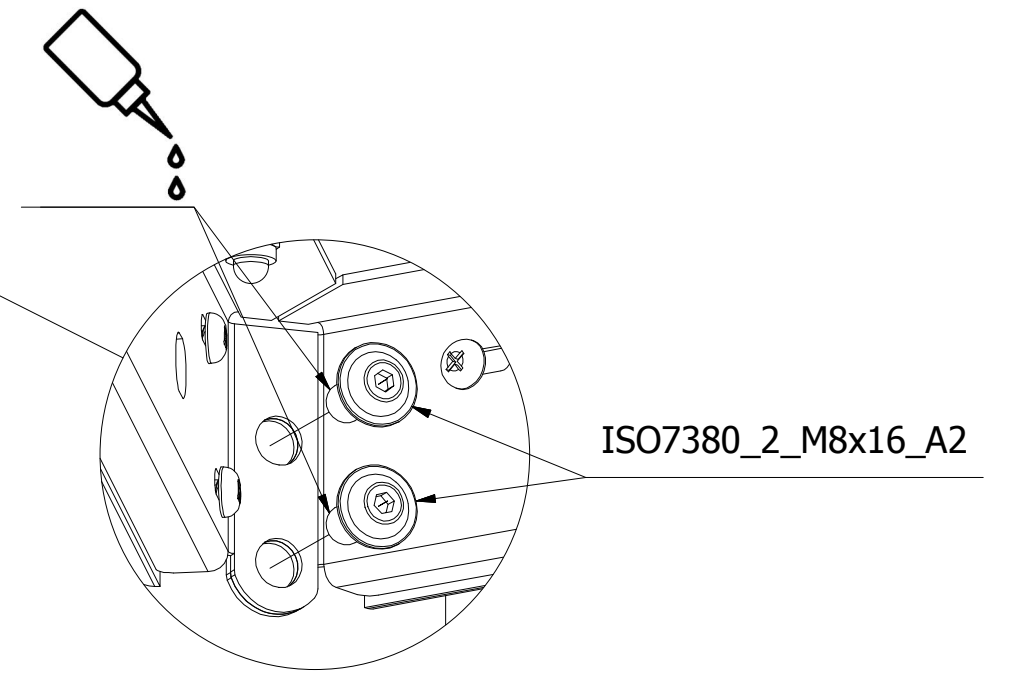
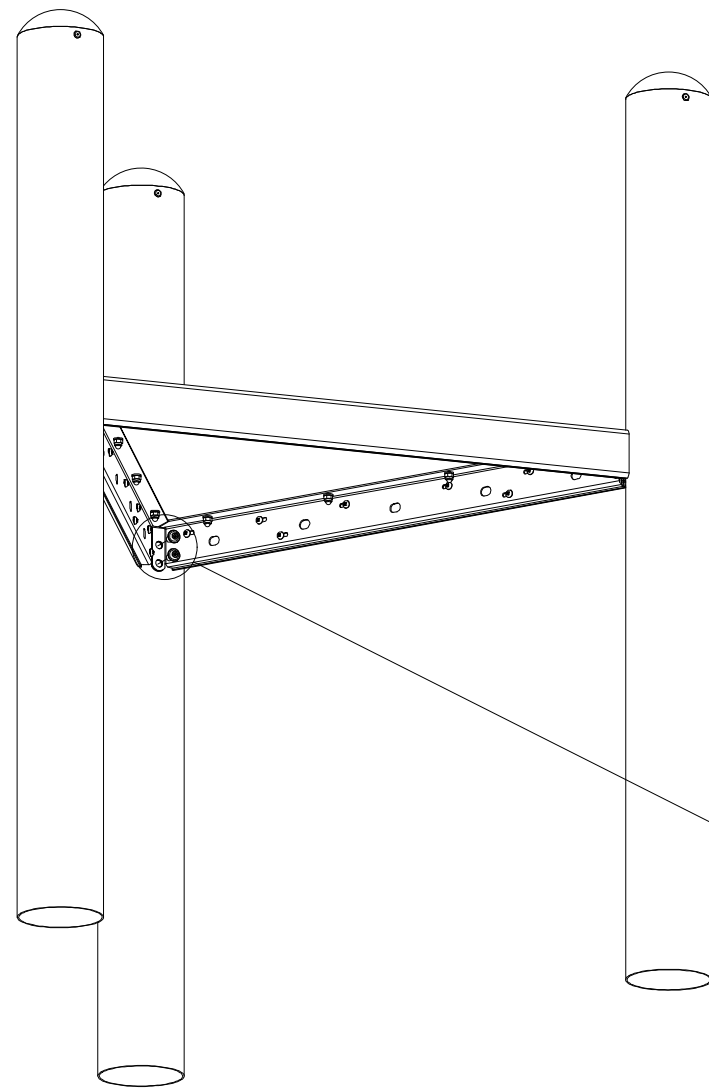
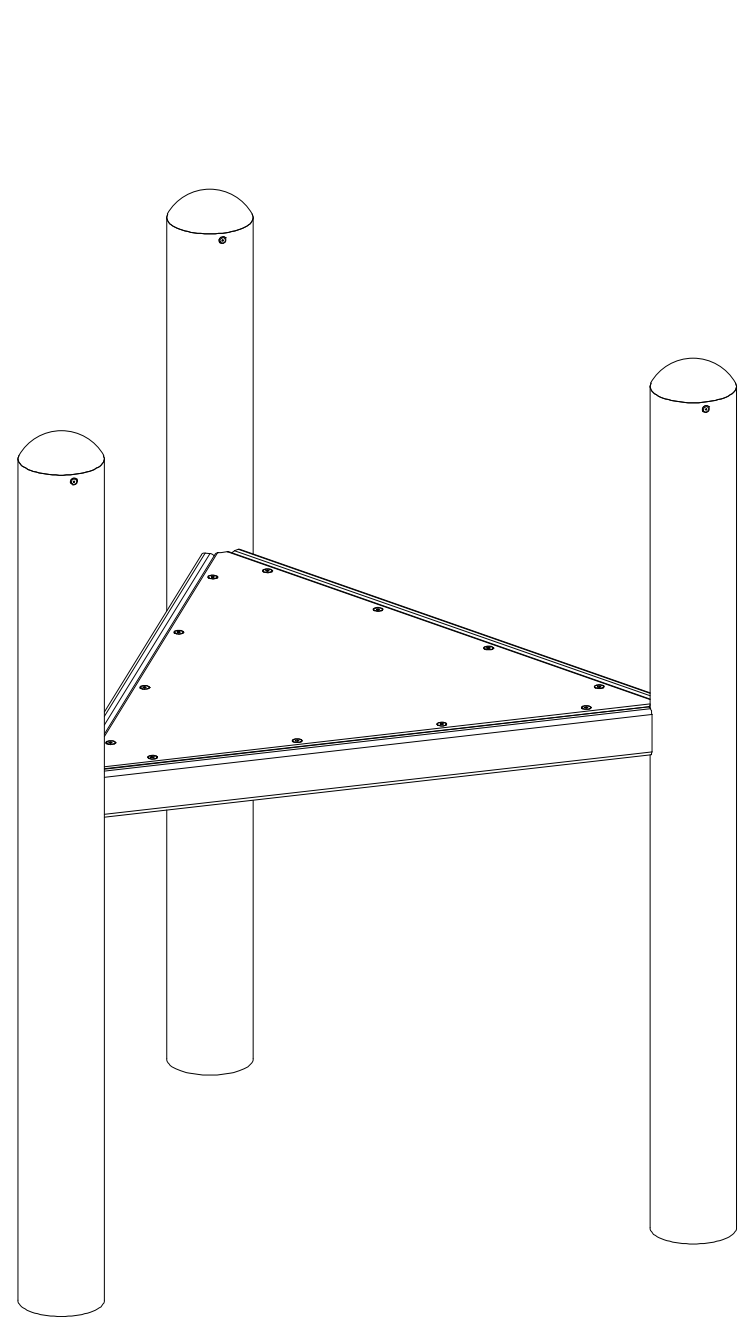

8919_001	2
DIN986_M8_A2	4
ISO7089_8_A2	4
ISO7380_2_M8x16_A2	2
ISO7380_2_M8x30_A2	2
ISO7380_2_M8x35_A2	2
ISO7380_2_M8x40_A2	2
Drawing/Norm number	Quantity

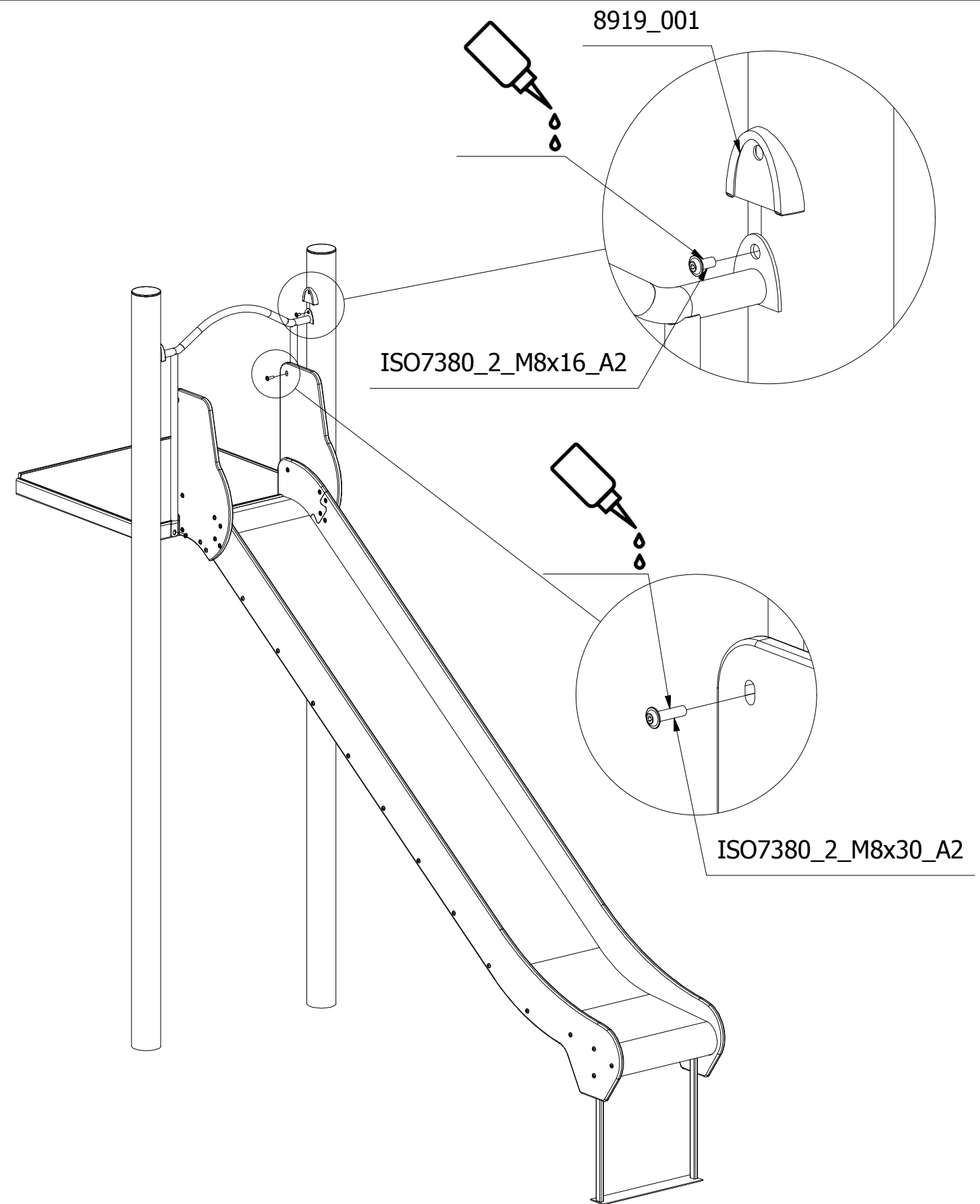
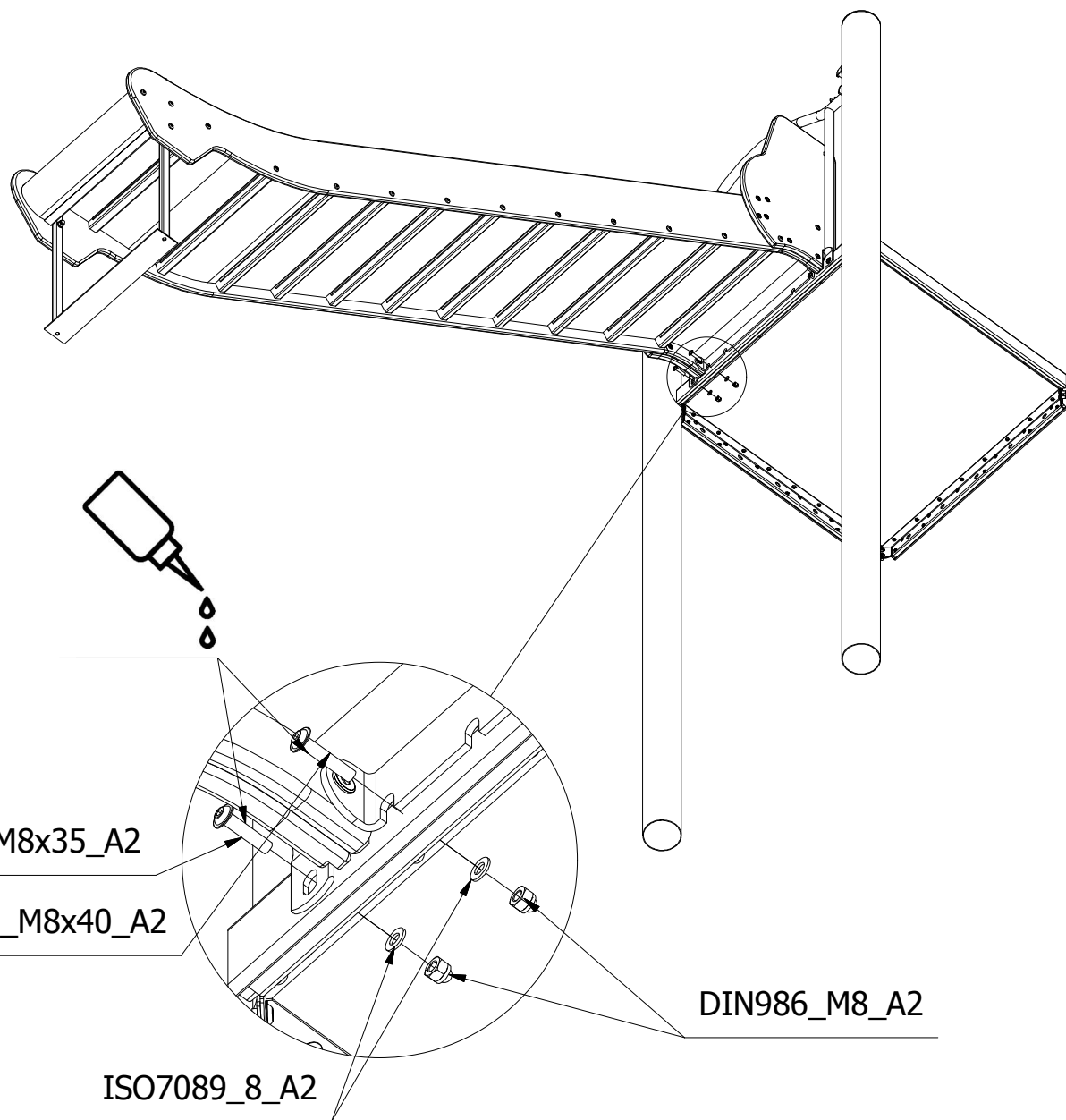

ISO7093_8_A2	16
ISO7380_2_M8x30_A2	16
Drawing/Norm number	Quantity

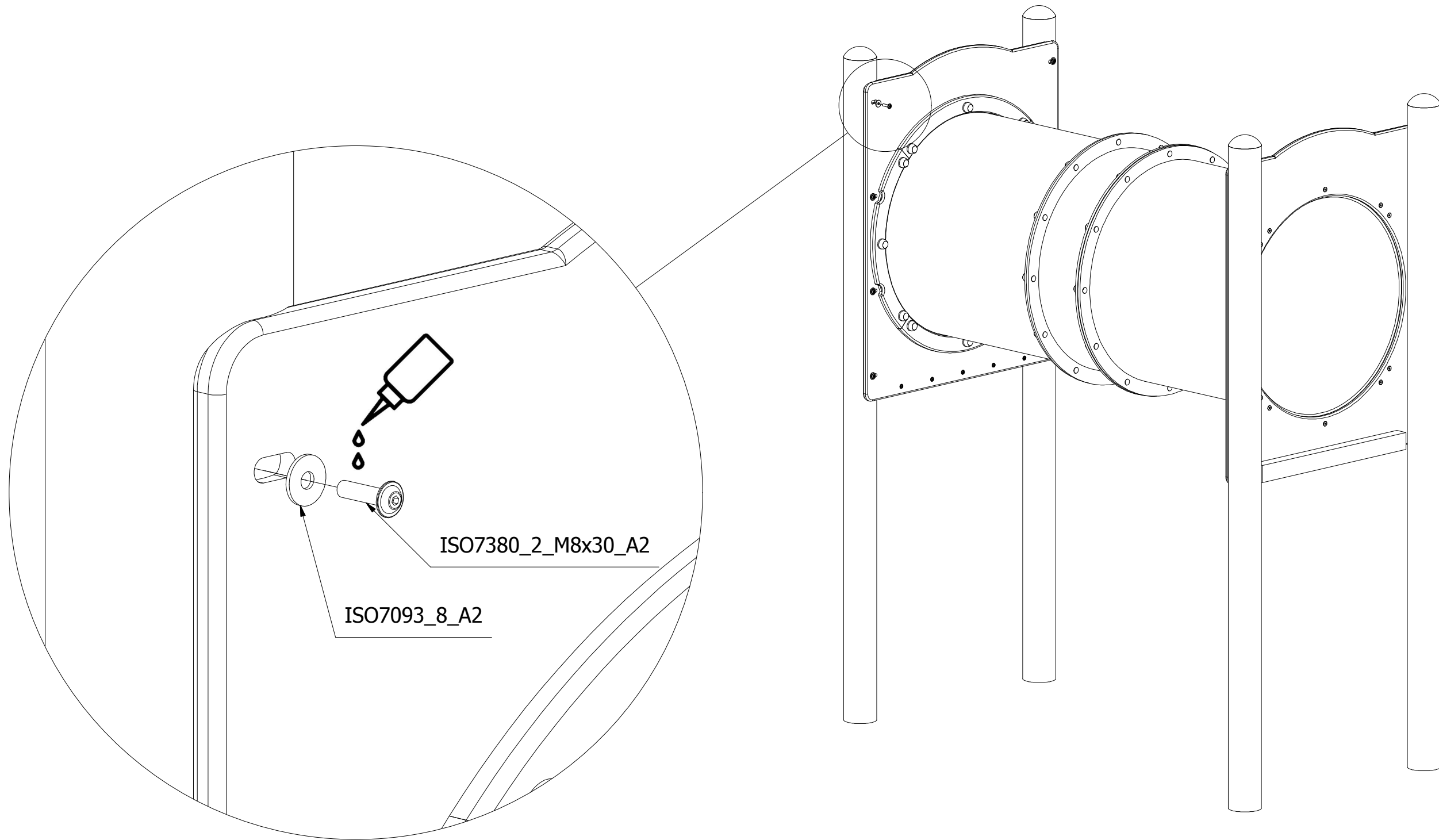

ISO7380_2_M8x16_A2	4
8919_001	4
Drawing/Norm number	Quantity

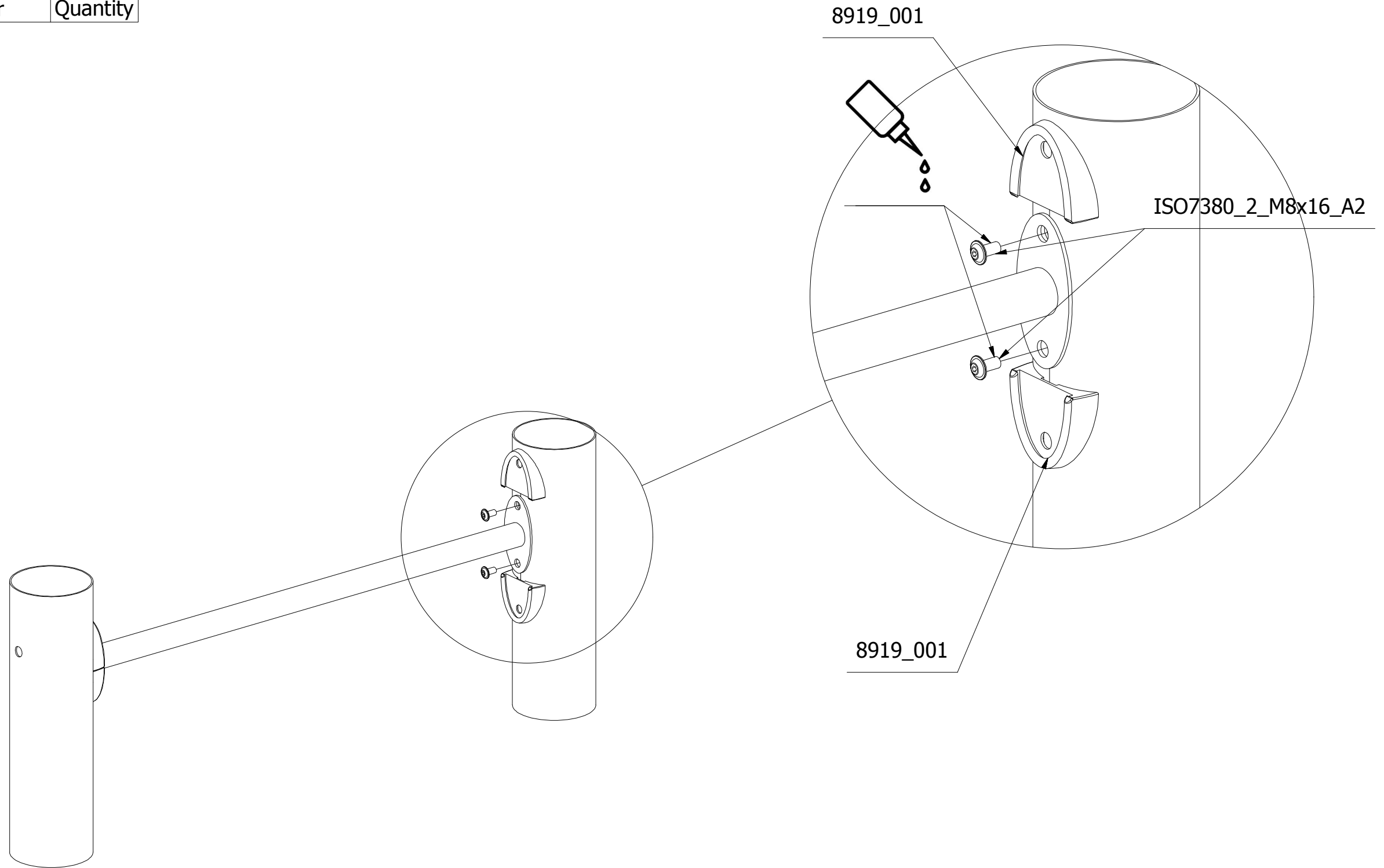

DIN986_M8_A2	2
ISO7089_8_A2	2
ISO7380_2_M8x35_A2	2
ISO7380_2_M8x16_A2	2
8919_001	2
Drawing/Norm number	Quantity

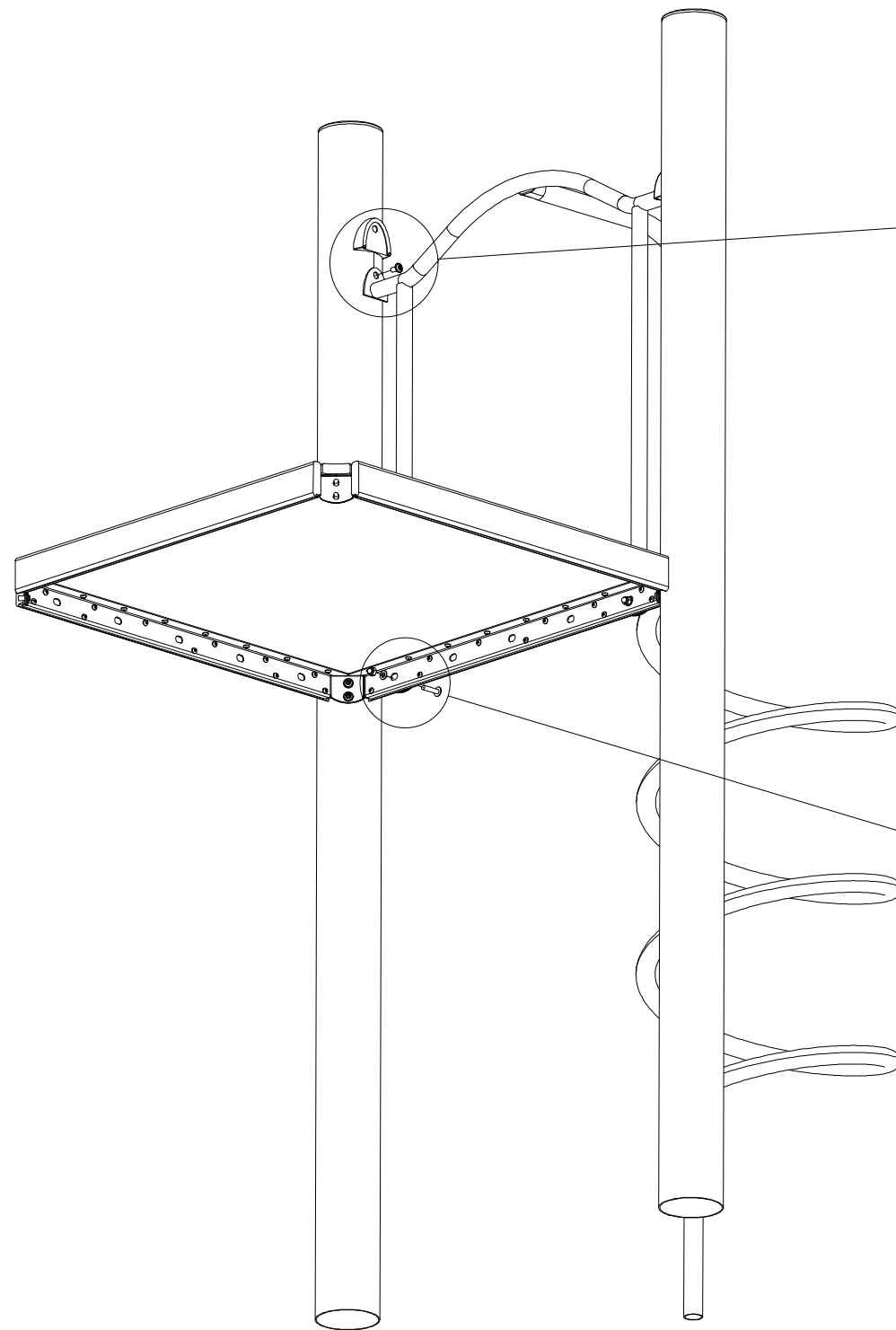

8919\_001

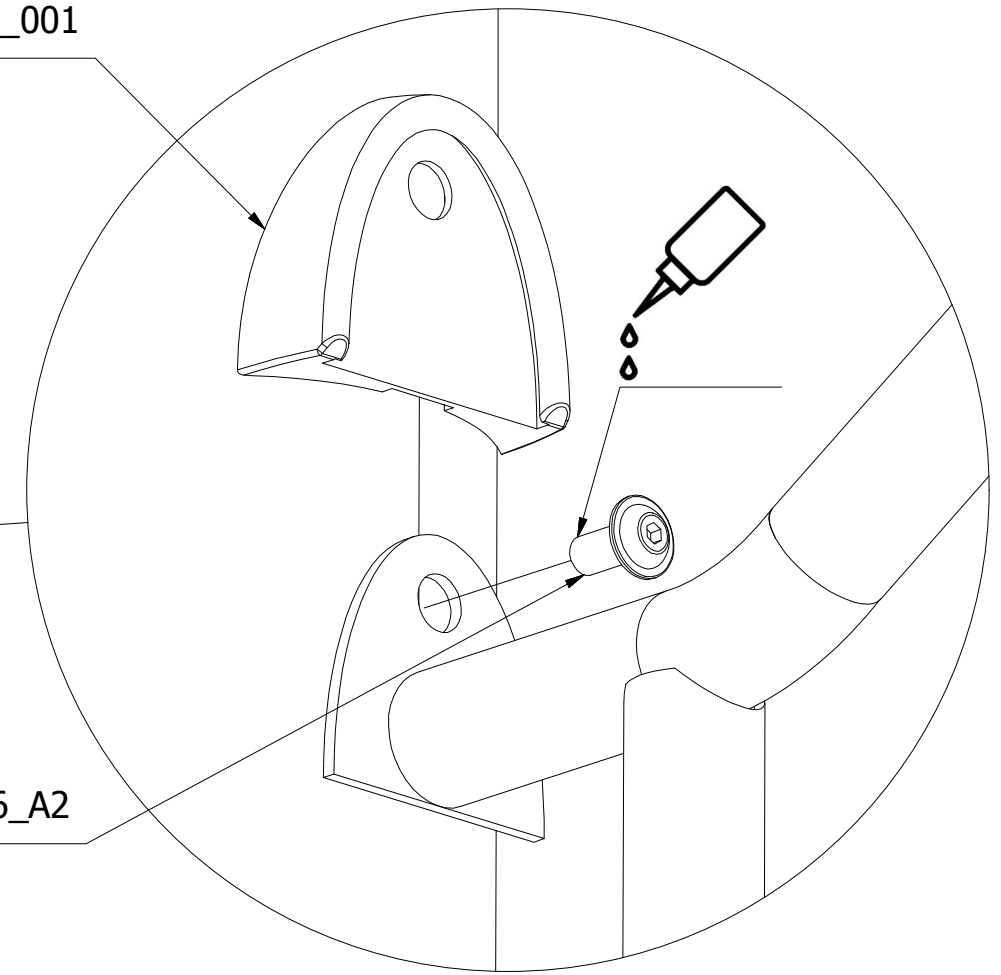

ISO7380\_2\_M8x16\_A2

DIN986\_M8\_A2

ISO7089\_8\_A2

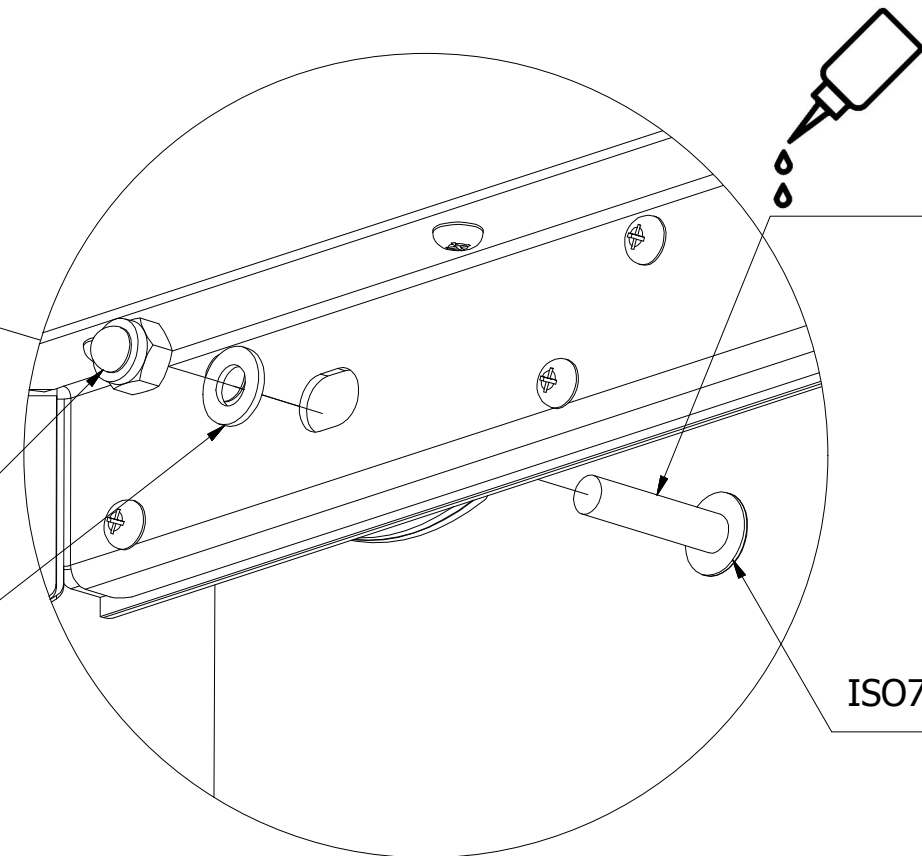

ISO7380\_2\_M8x35\_A2

DIN986_M8_A2	2
ISO7380_2_M8x35_A2	2
ISO7089_8_A2	2
ISO7380_2_M8x16_A2	2
8919_001	2
Drawing/Norm number	Quantity

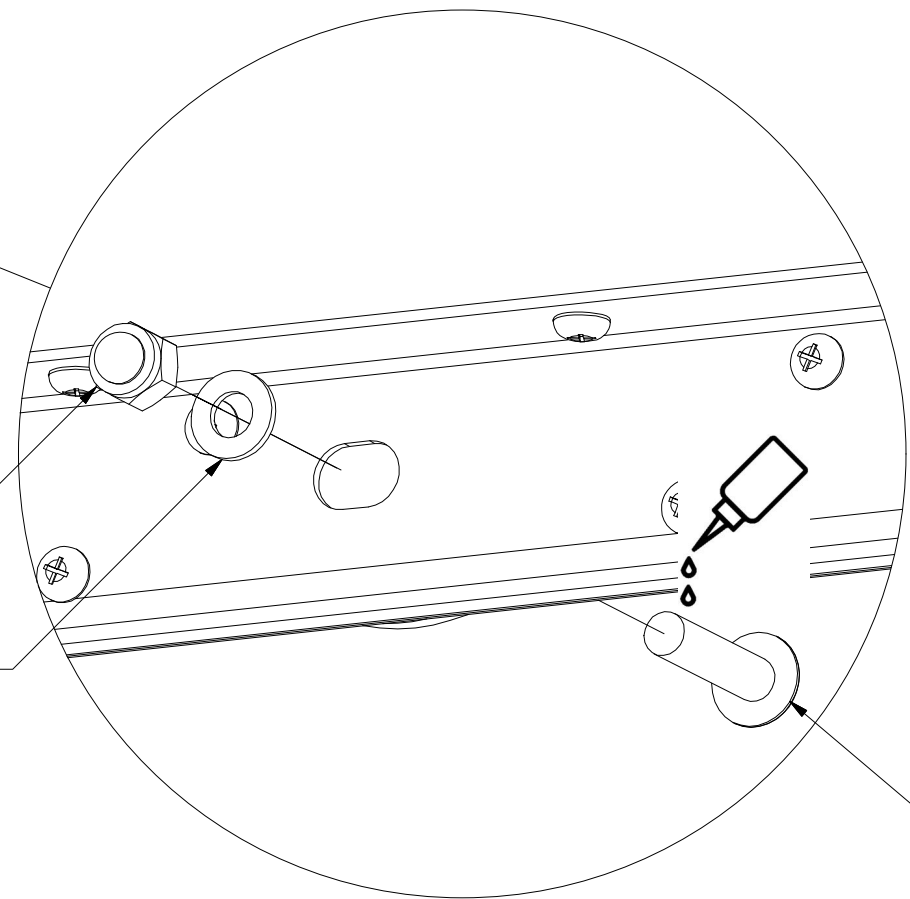
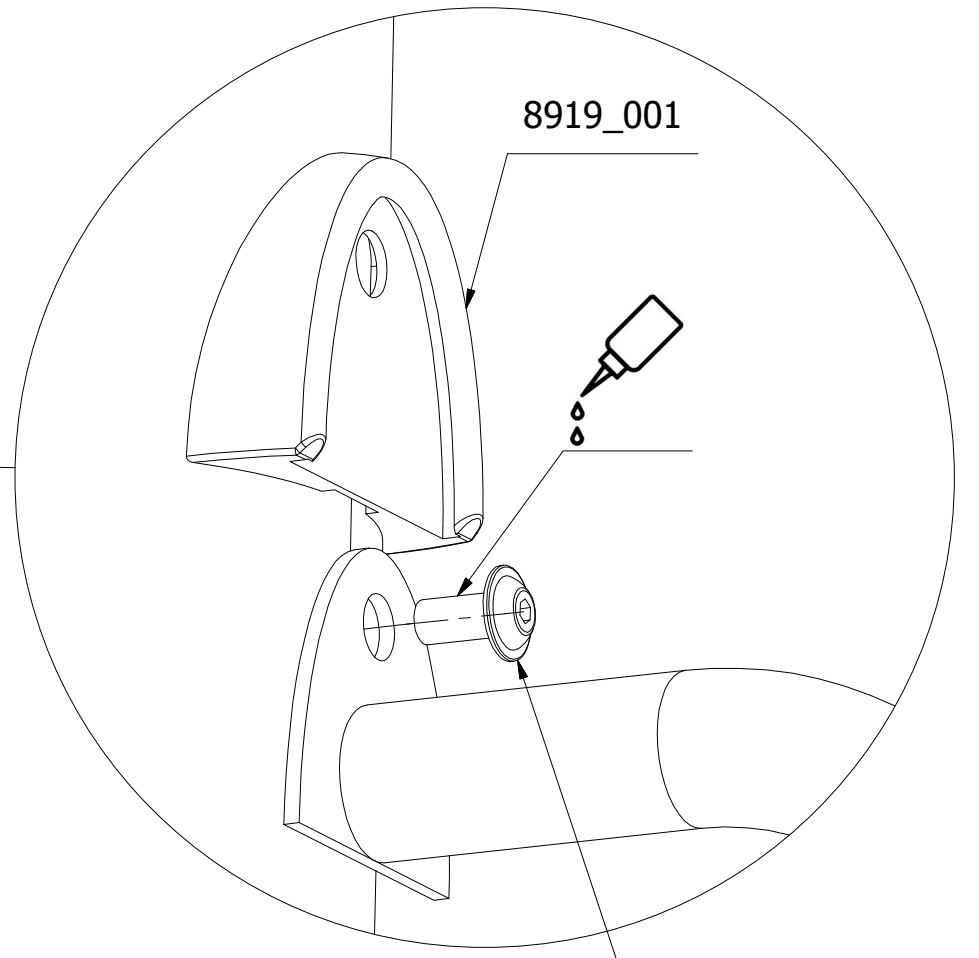
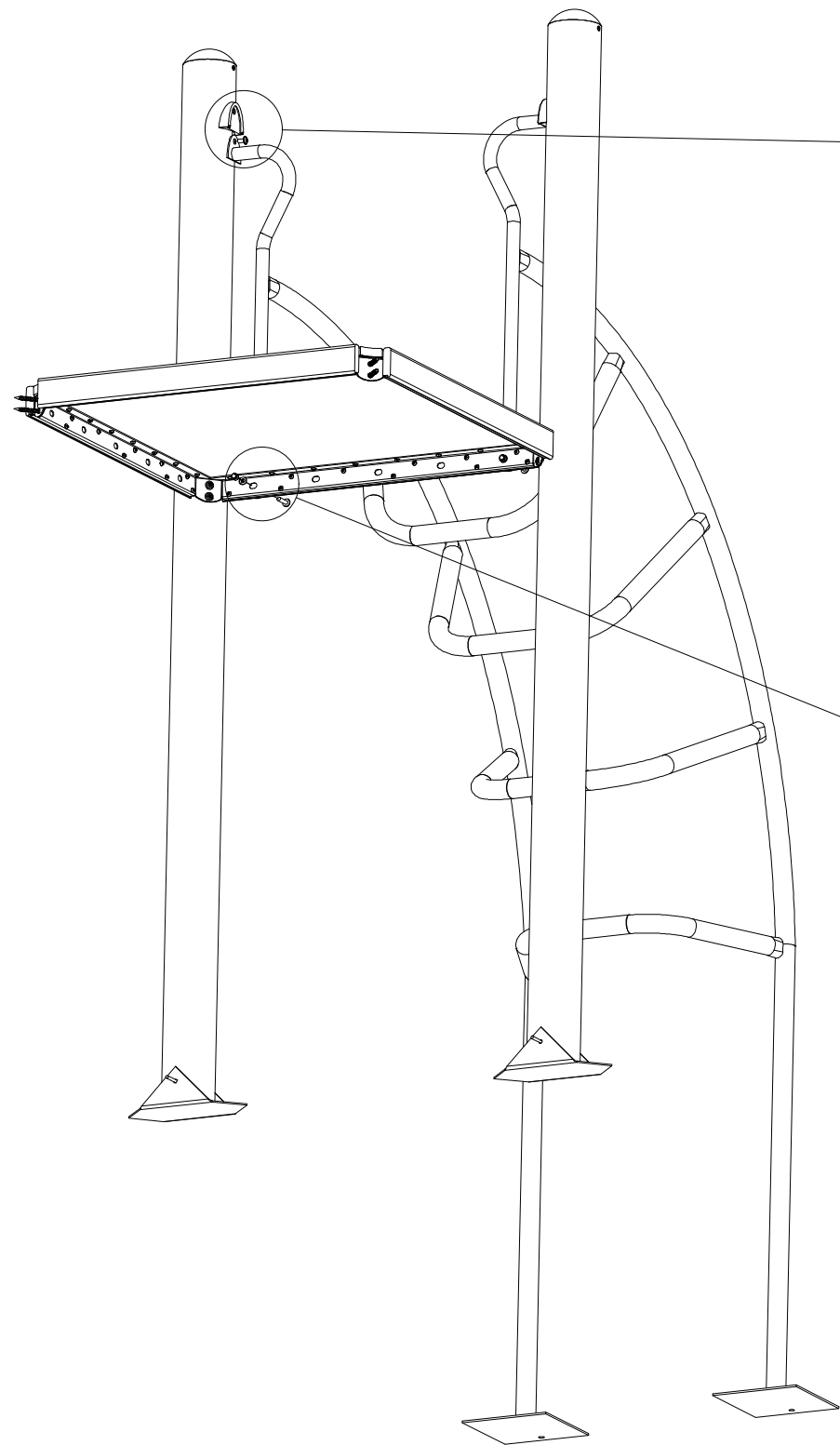

ISO7380\_2\_M8x16\_A2

ISO7380\_2\_M8x35\_A2



Cat. no.

**23104\_RM**

2024-07-23

1 / 1

ISO7380_2_M6x12_A2	8
ISO7380_2_M6x30_A2	3
8919_001	18
ISO7380_2_M8x16_A2	18
8902_007_A2	11
Drawing/Norm number	Quantity

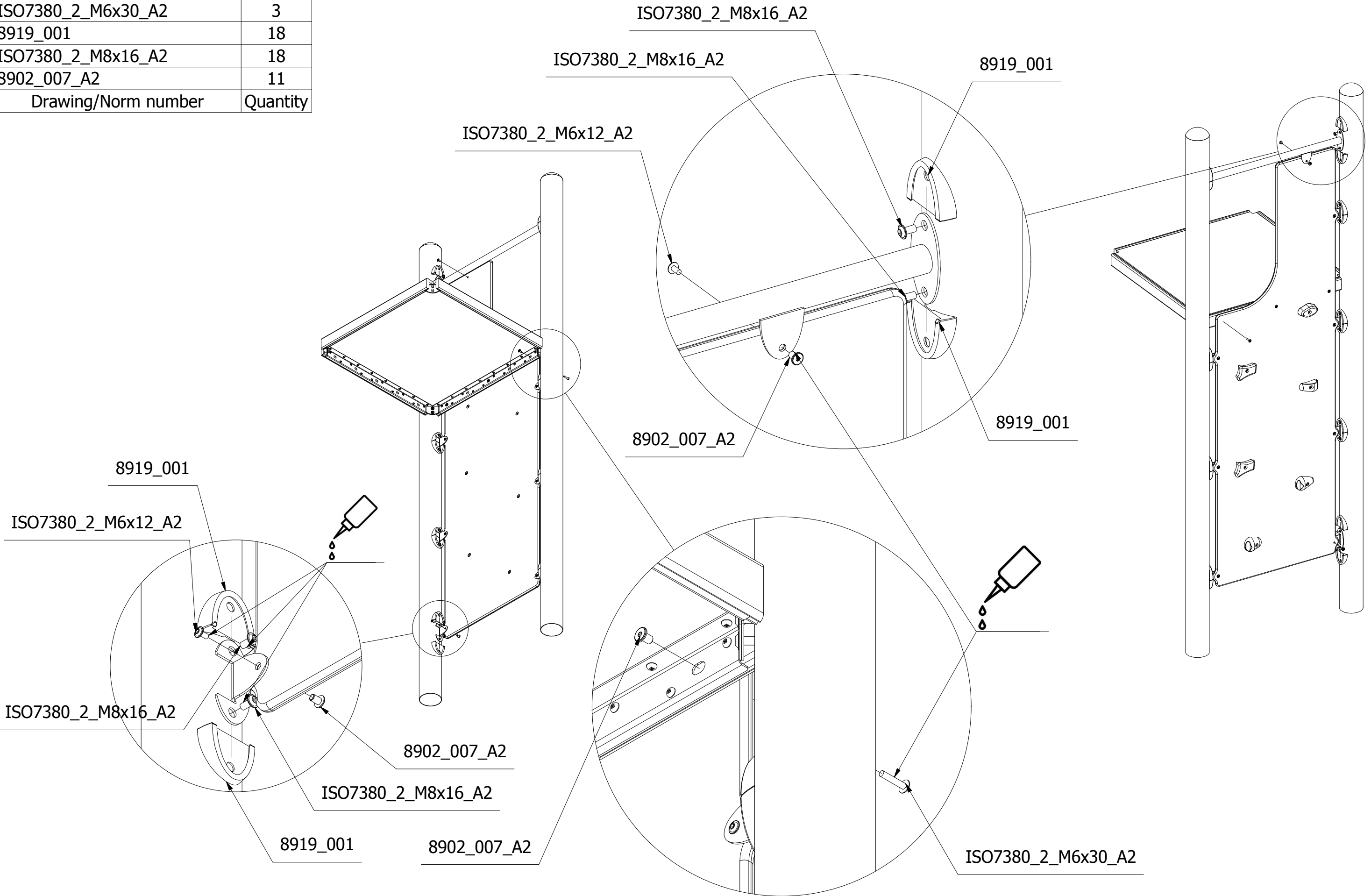

ISO7380_2_M8x16_A2	2
ISO7380_2_M8x35_A2	2
DIN986_M8_A2	2
ISO7089_8_A2	2
8919_001	2
Drawing/Norm number	Quantity

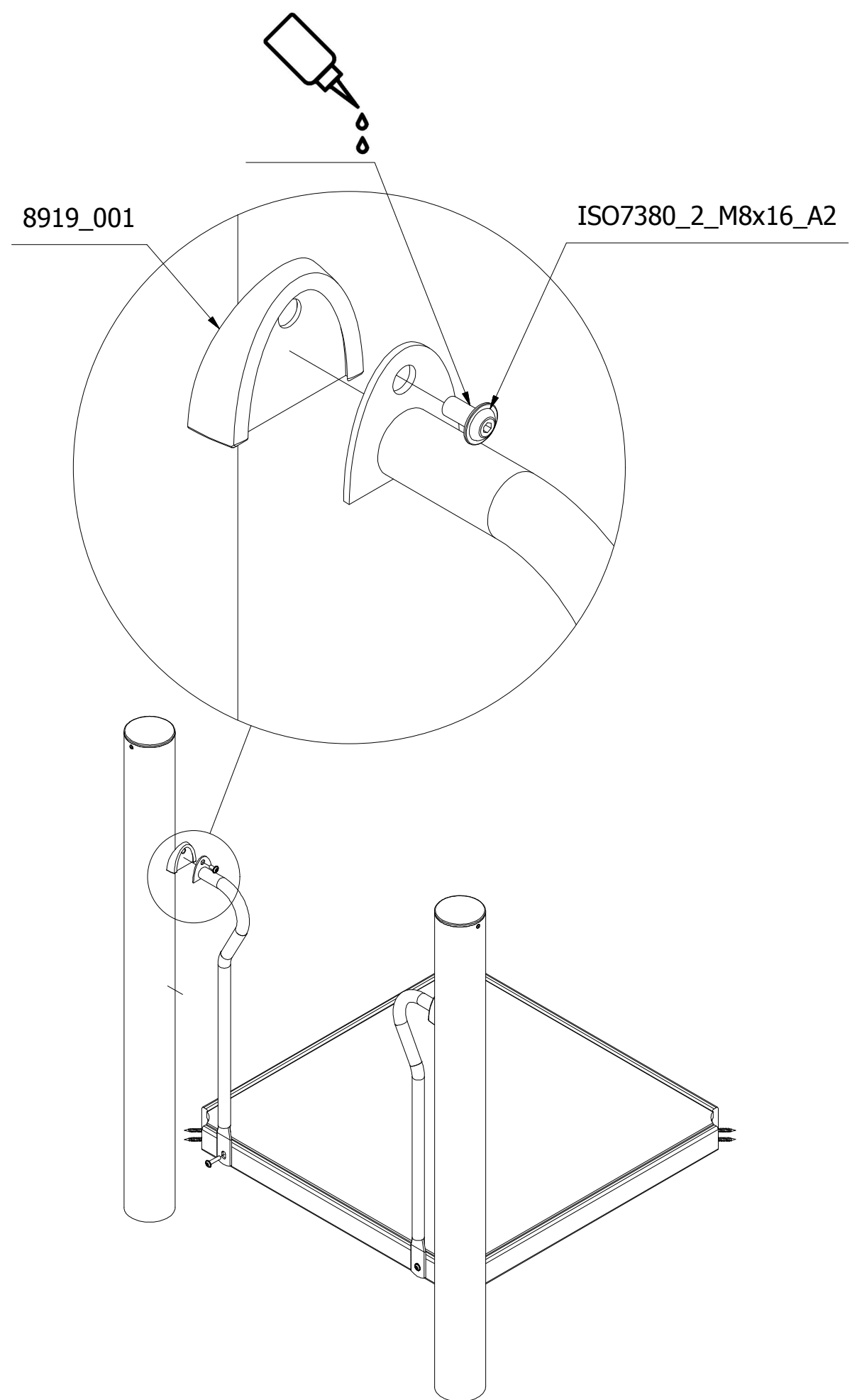
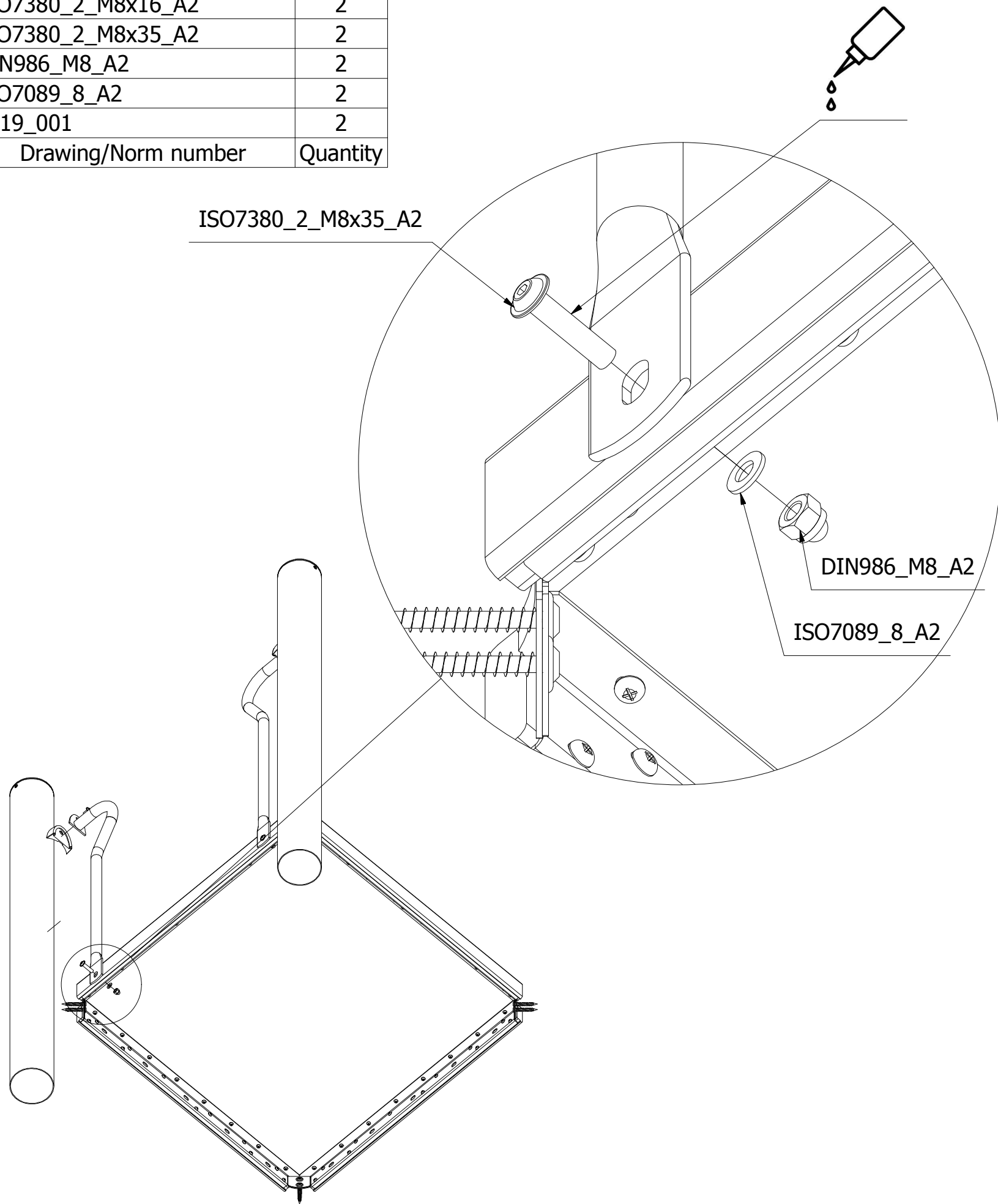

ISO7380_2_M8x16_A2	8
B_8801_041	4
ISO7380_2_M6x10_A2	4
8902_007_A2	4
8919_001	8
Drawing/Norm number	Quantity

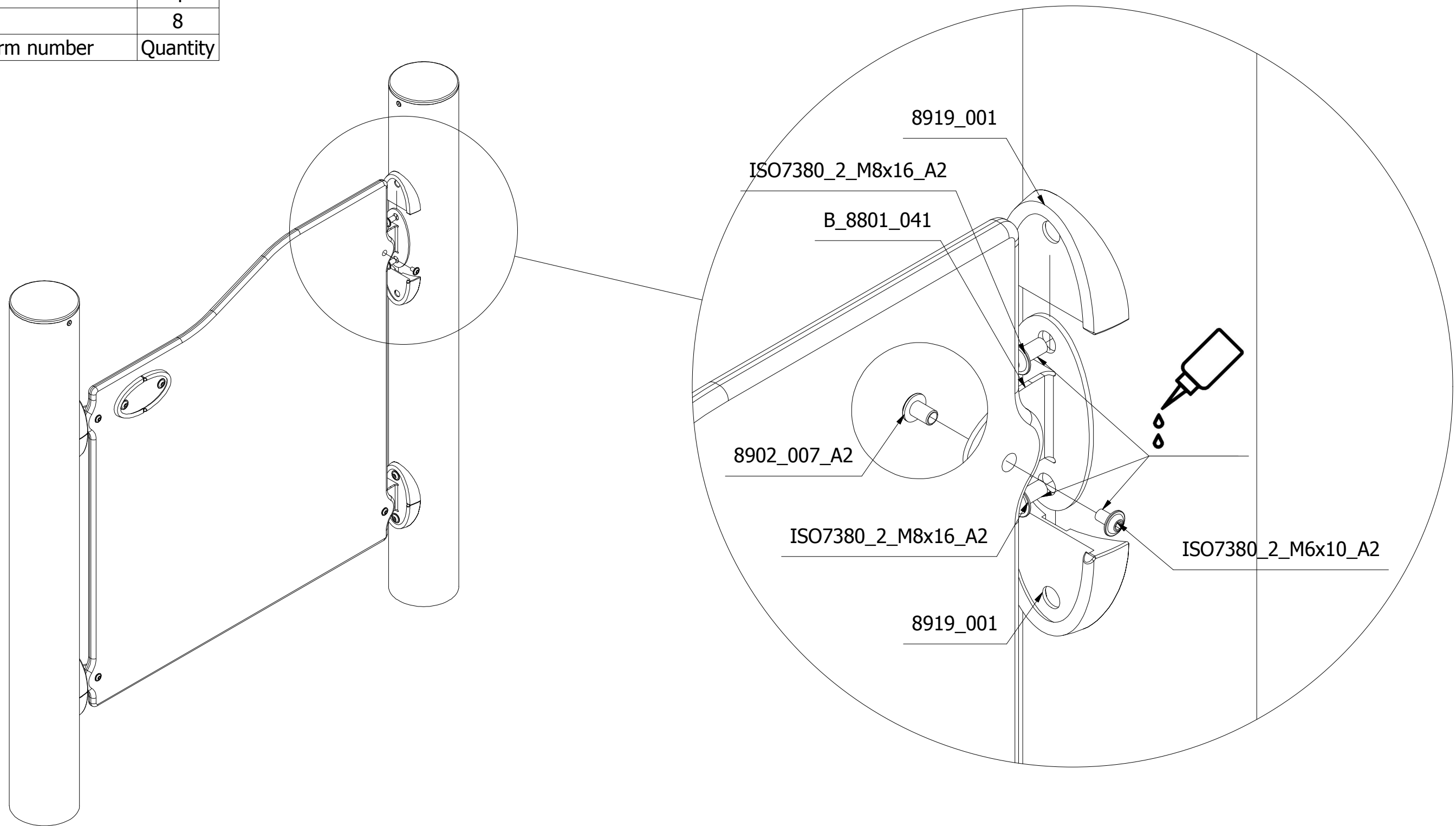

Cat. no.

**2403\_RM**

2024-05-08

1 / 4

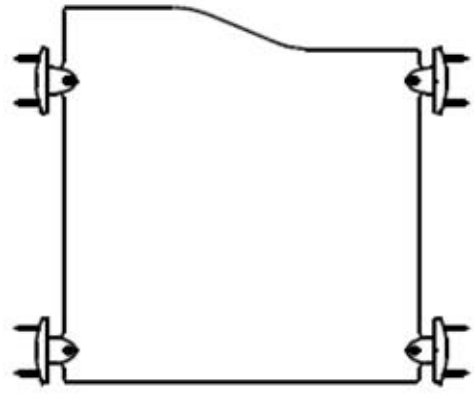

2403\_37

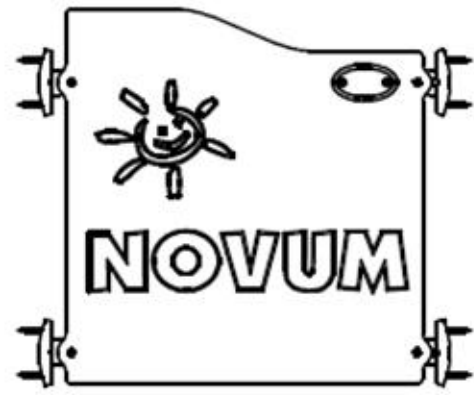

2403\_01

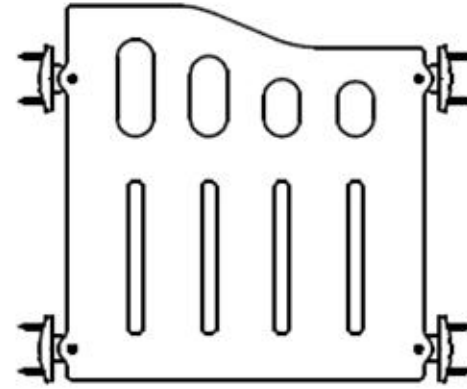

2403\_18

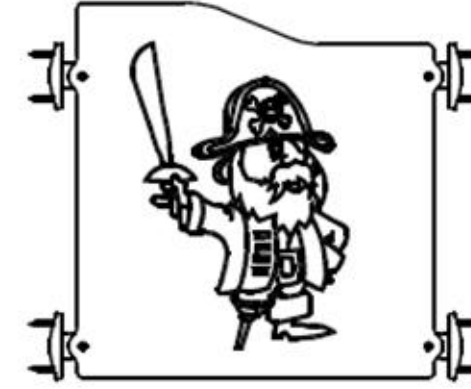

2403\_20

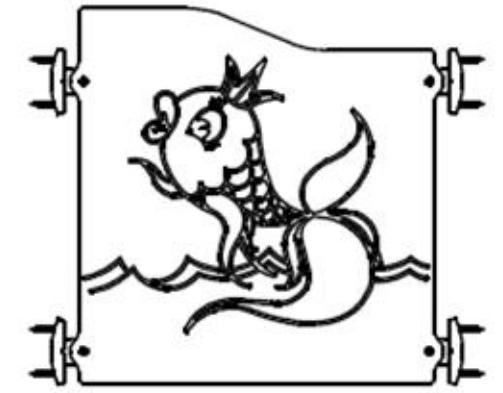

2403\_22

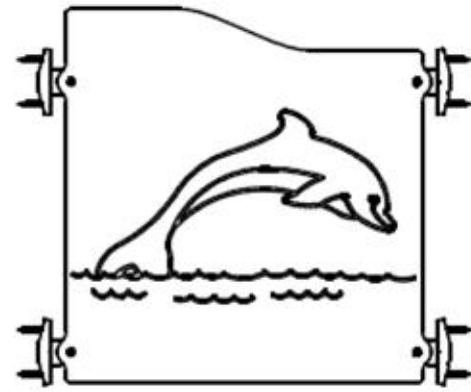

2403\_23

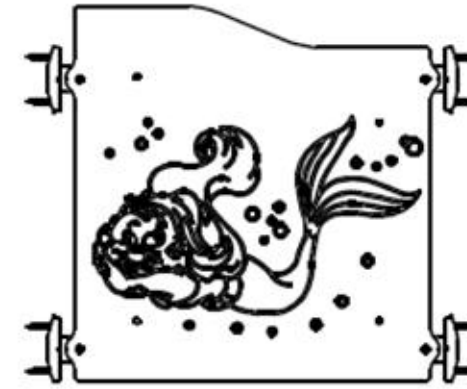

2403\_24

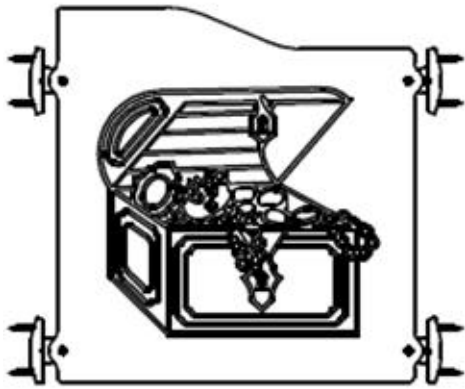

2403\_25

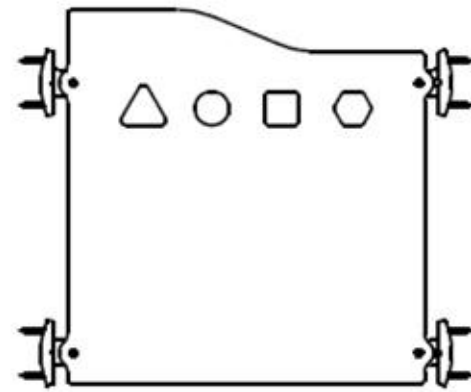

2403\_26

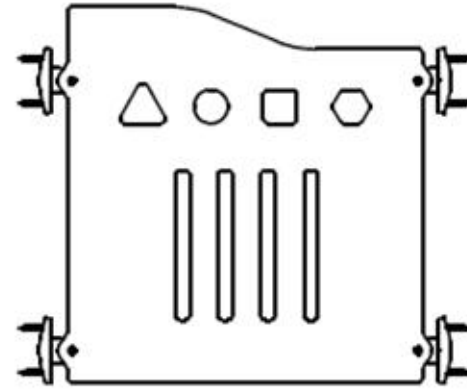

2403\_27

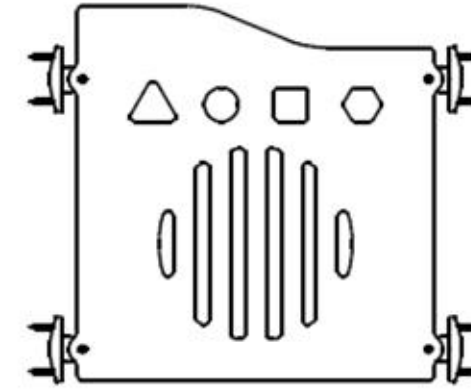

2403\_28

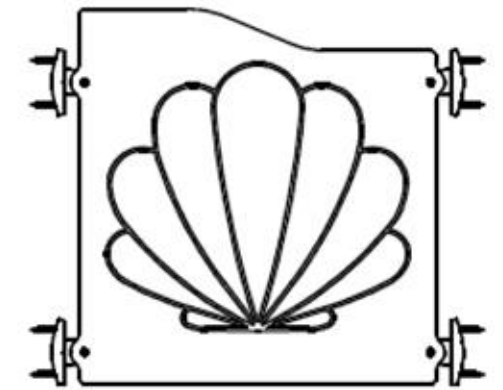

2403\_31



2403\_10



2403\_11

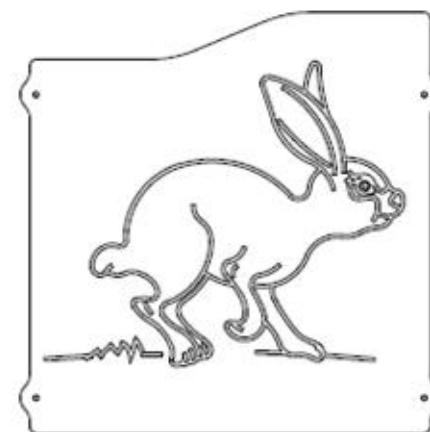

2403\_12

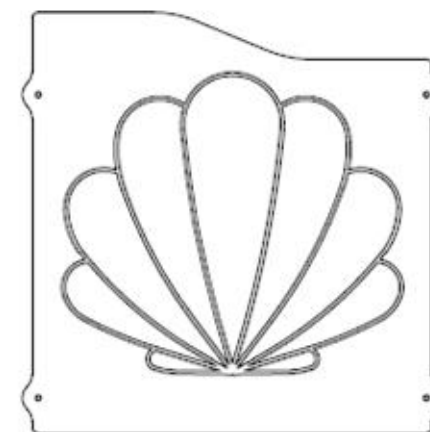

2403\_31

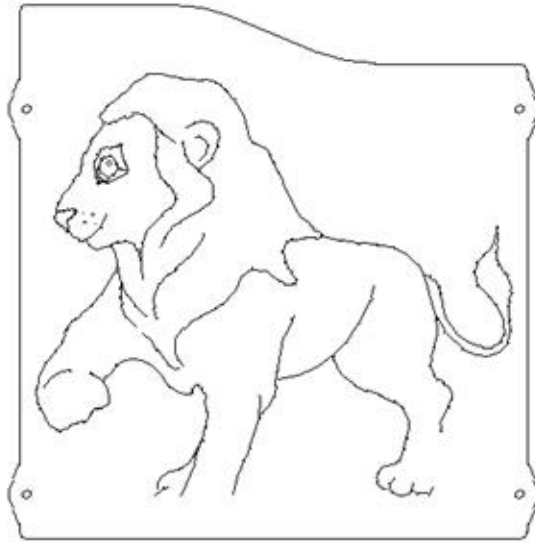

2403\_02

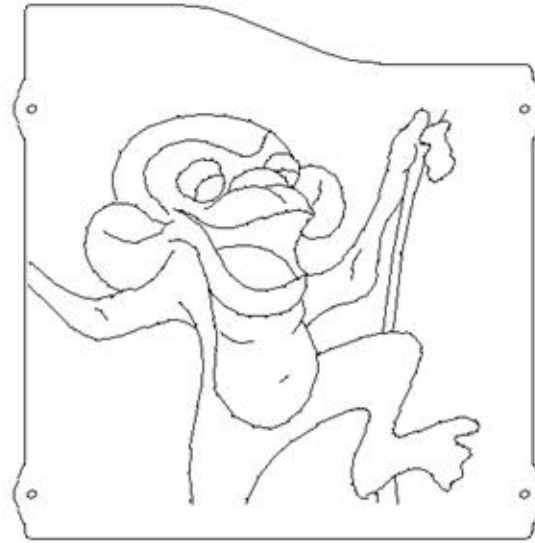

2403\_03

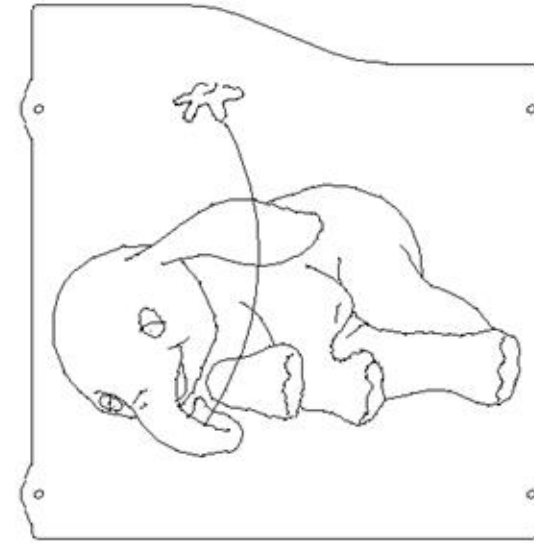

2403\_04

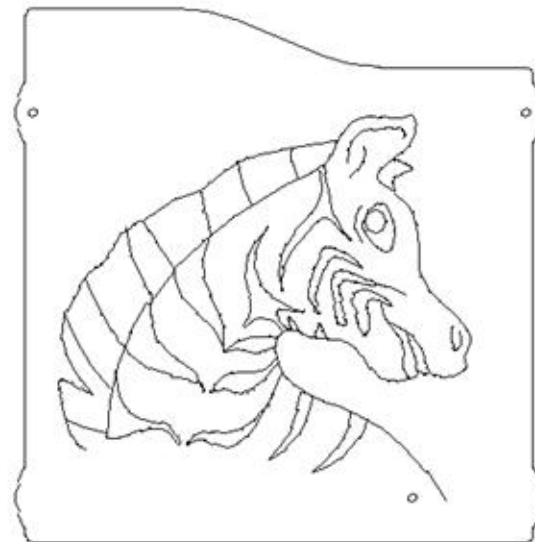

2403\_05

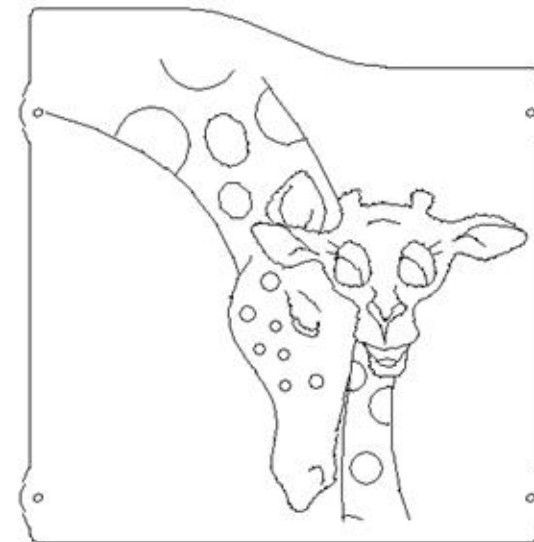

2403\_06

ISO7380_2_M6x12_12	42
8902_007_M6_A2	42
B_8801_042	18
B_8801_043P	6

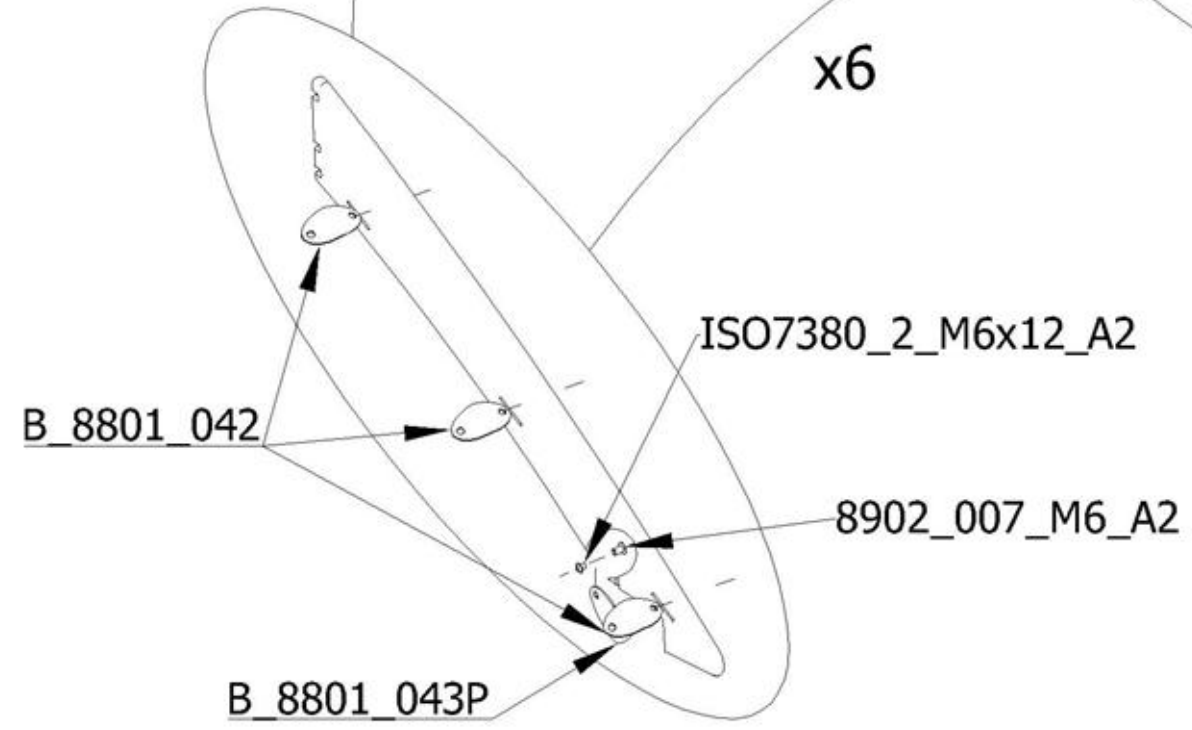
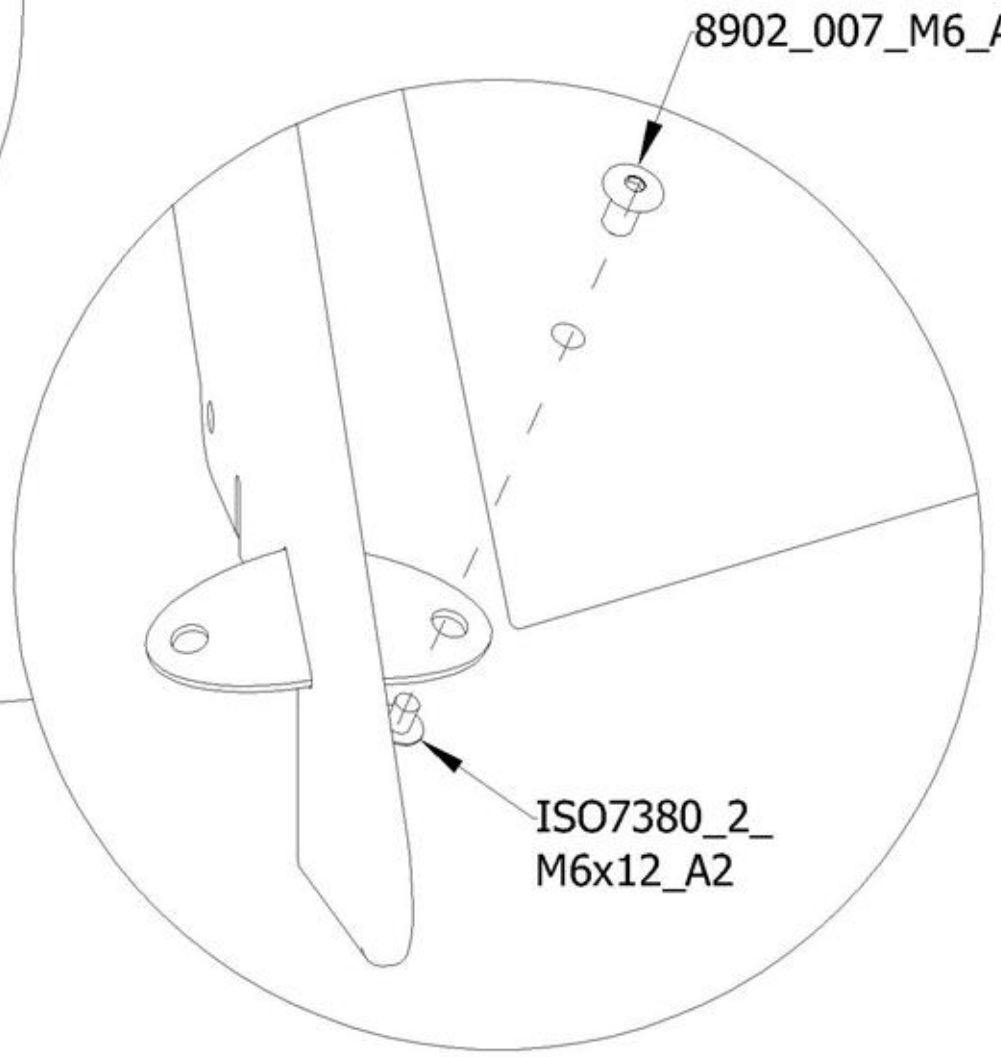
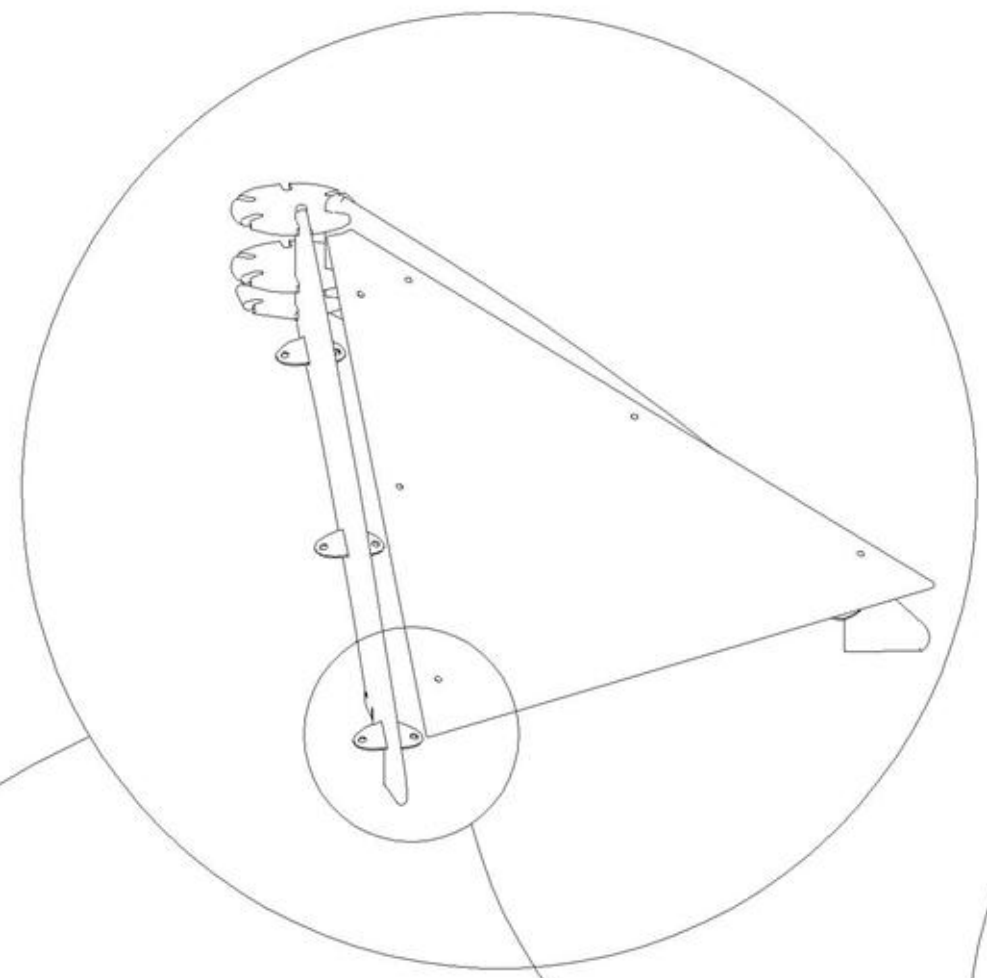
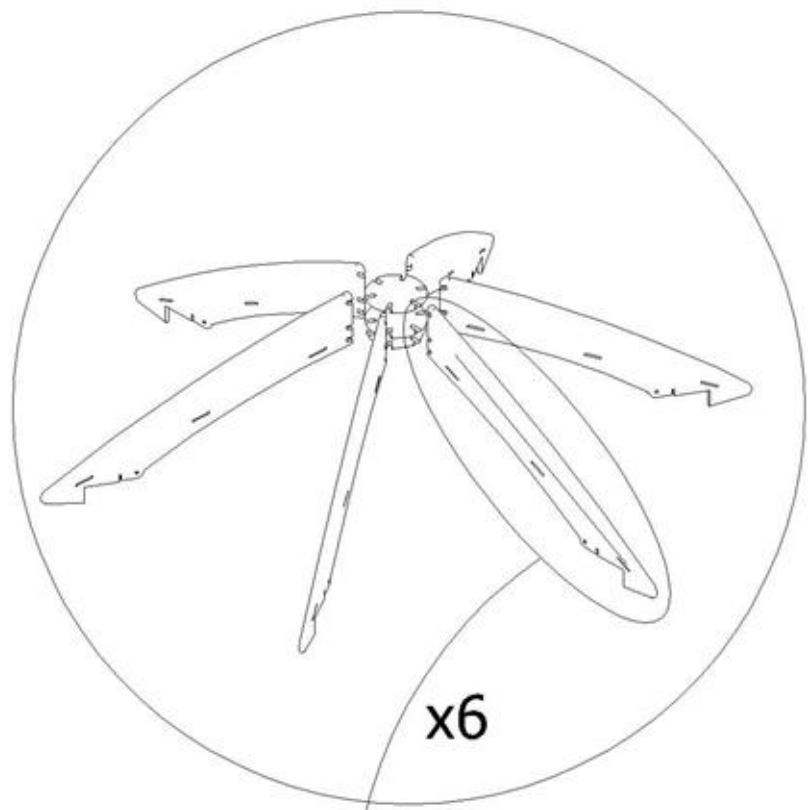

ISO7380_2_M8x16_A2	6
ISO7380_2_M6x12_A2	42
B_8801_043P	6
8902_007_A2	42
Drawing/Norm number	Quantity

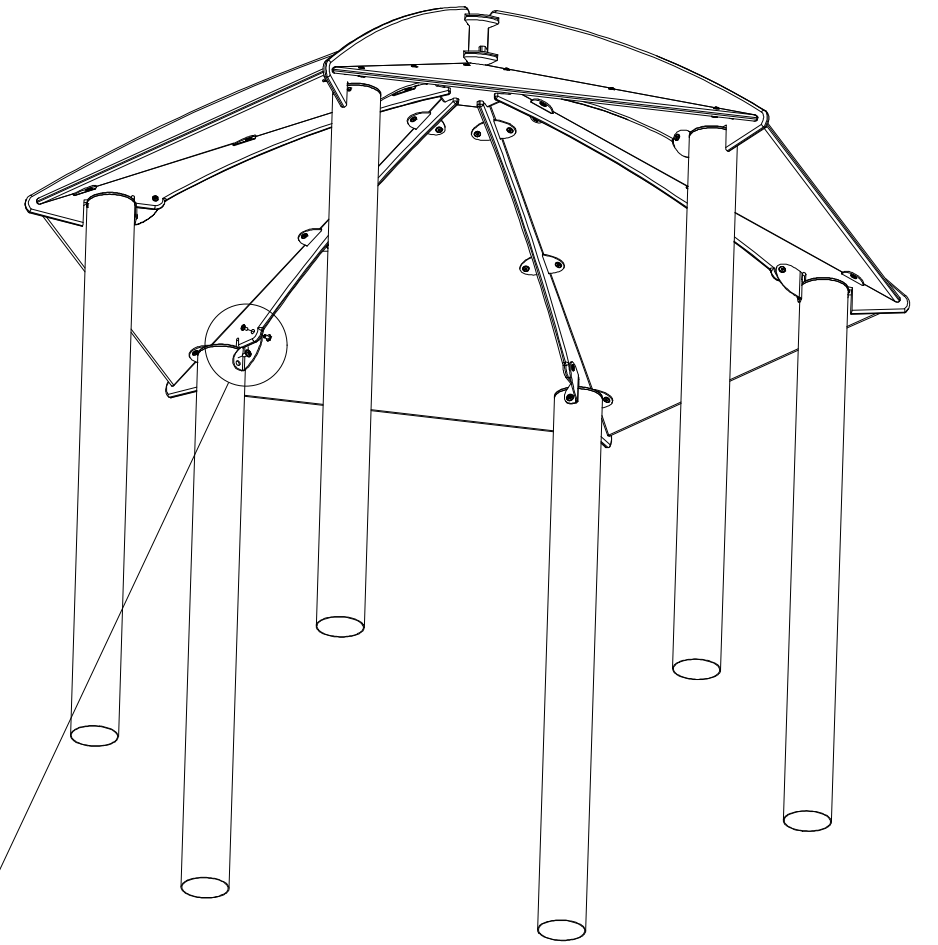
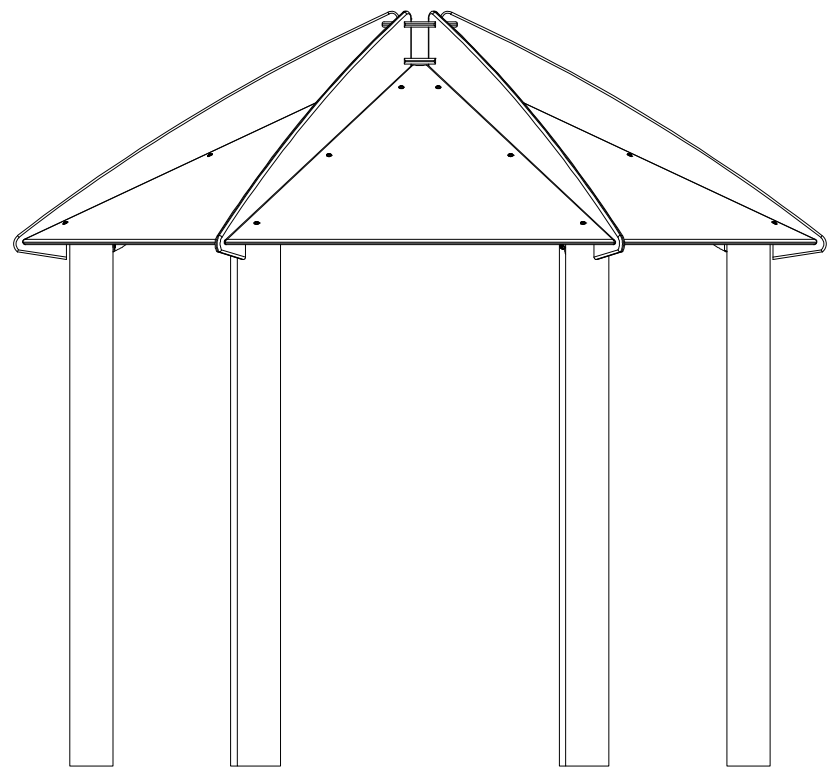

ISO7380\_2\_M6x12\_A2

ISO7380\_2\_M8x16\_A2

8902\_007\_A2

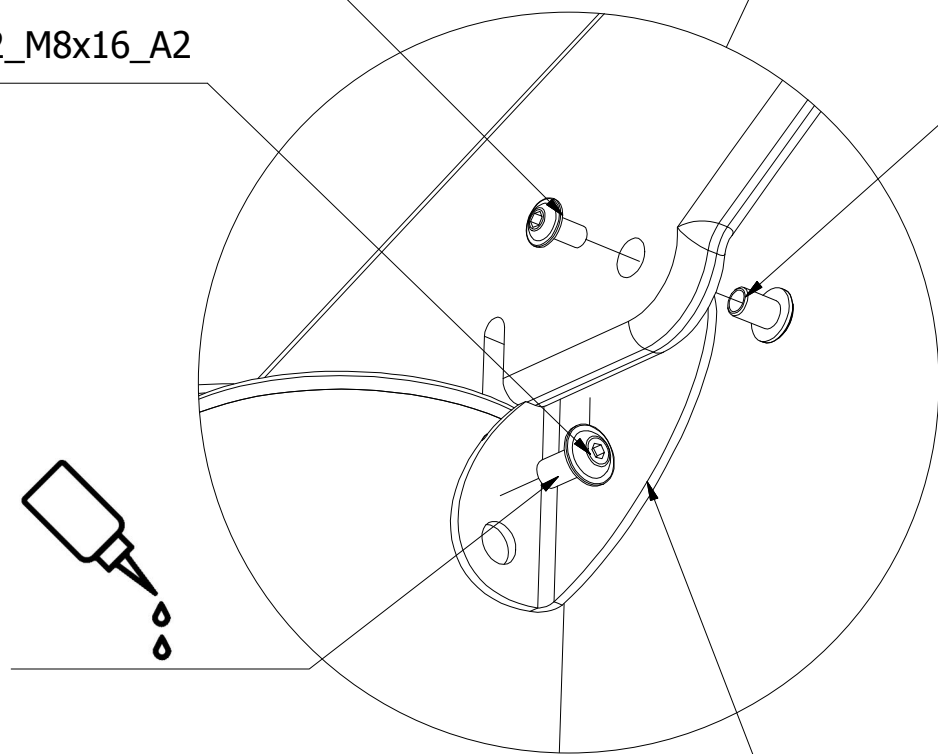

B\_8801\_043P

ISO7380_2_M8x16_A2	4
ISO7380_2_M6x12_A2	4
8902_007_A2	4
B_8801_040P	4
Drawing/Norm number	Quantity

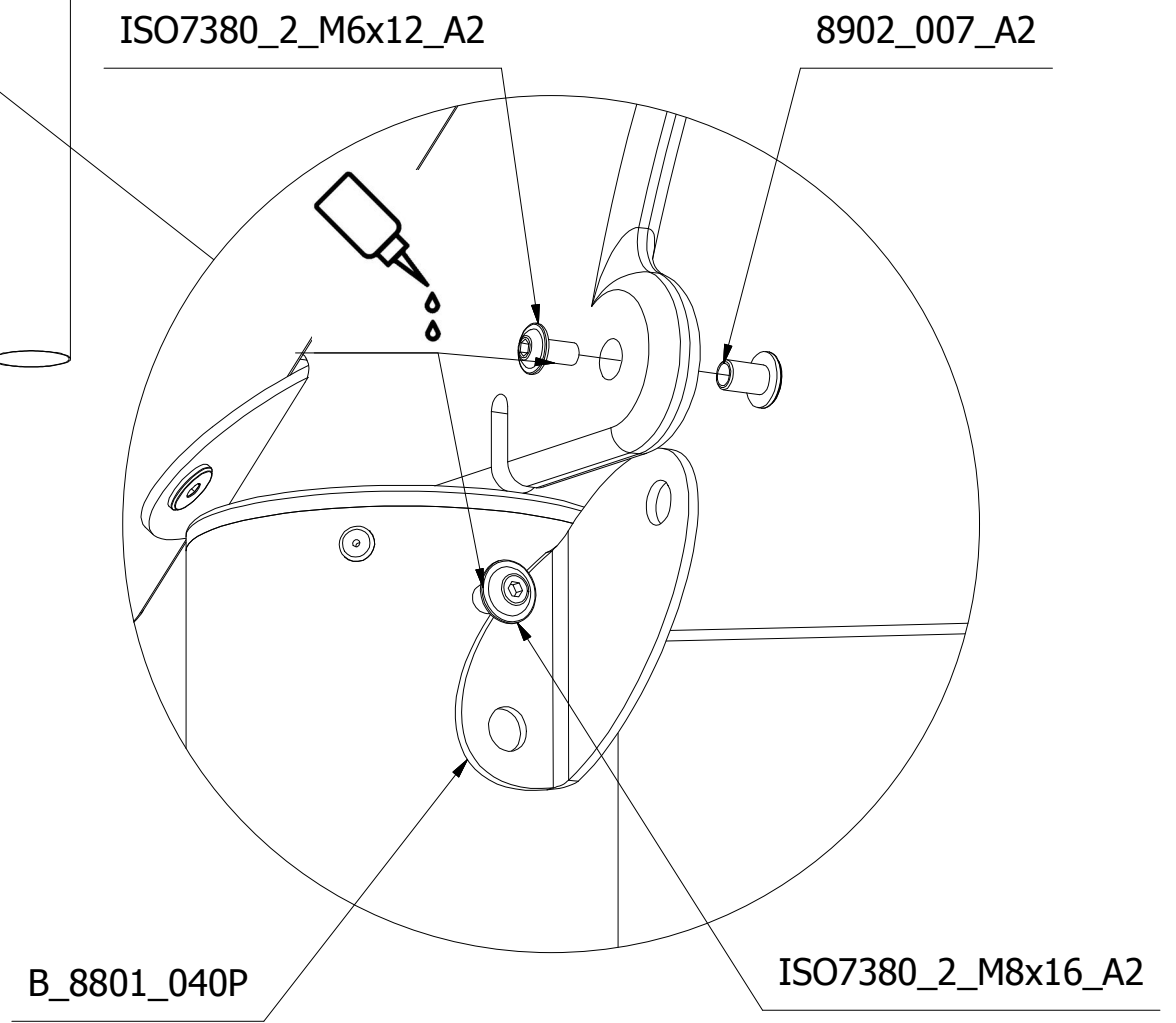
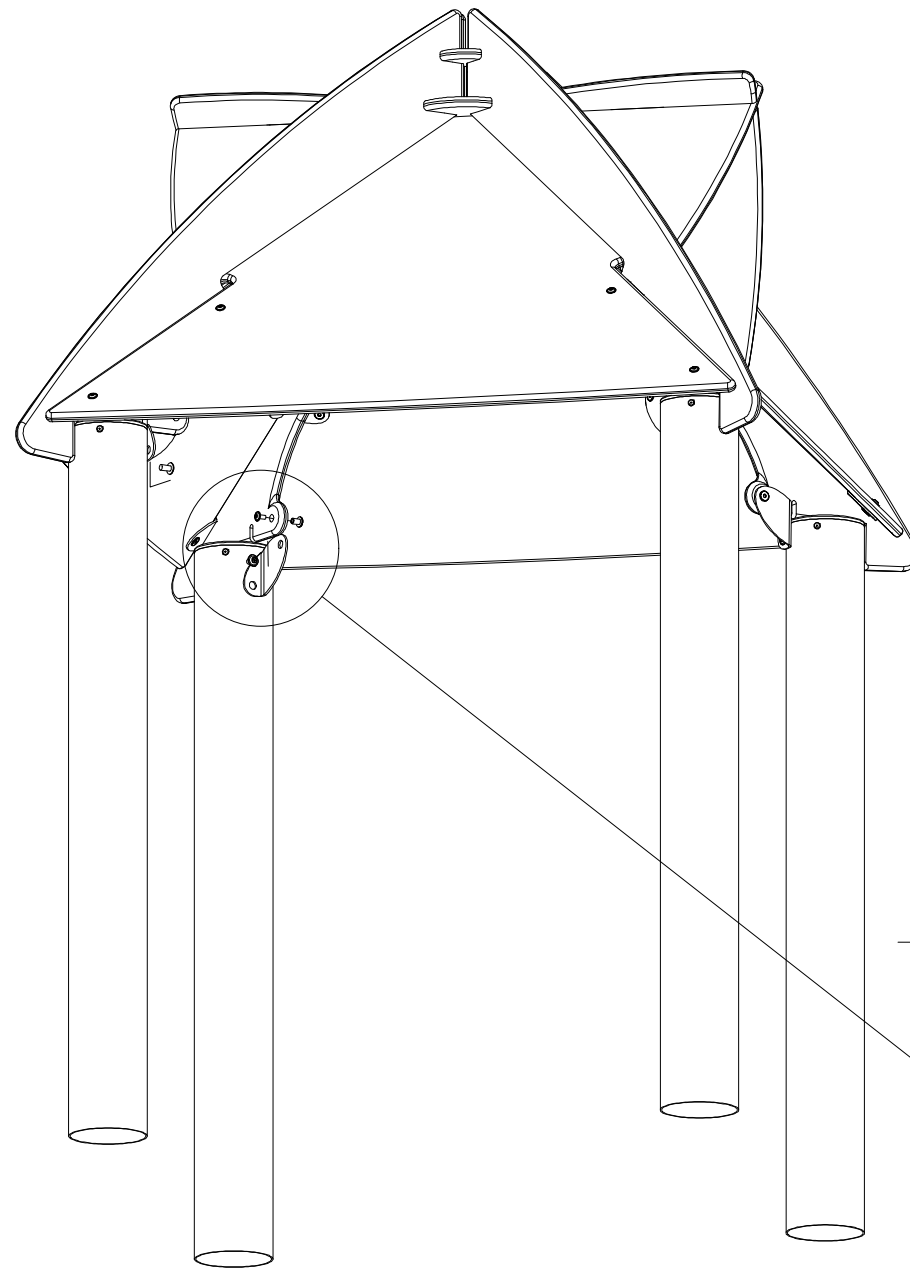
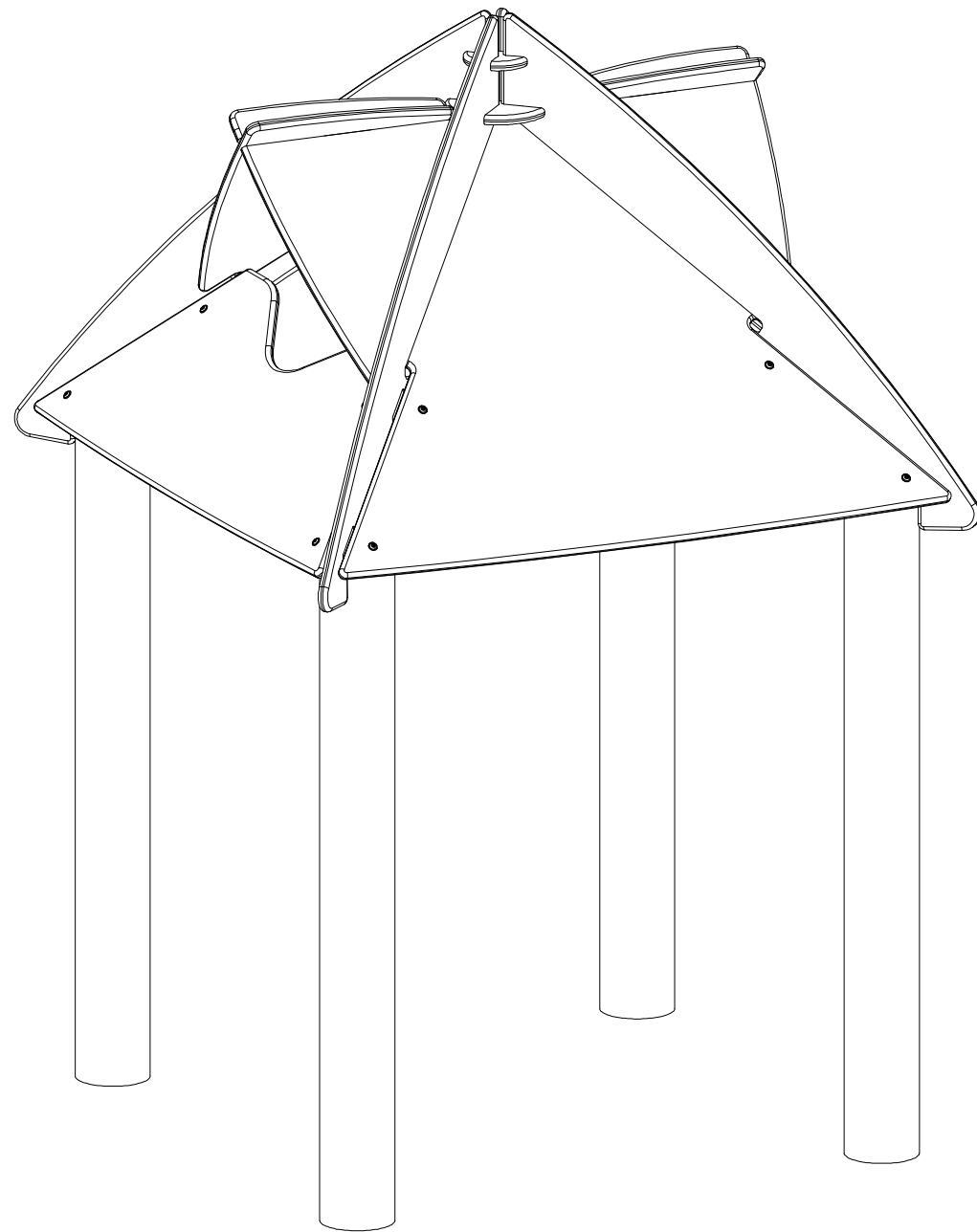

ISO7380_2_M8x16_A2	12
B_8801_041	6
8902_007_A2	6
ISO7380_2_M6x20_A2	6
8919_001	12
Drawing/Norm number	Quantity

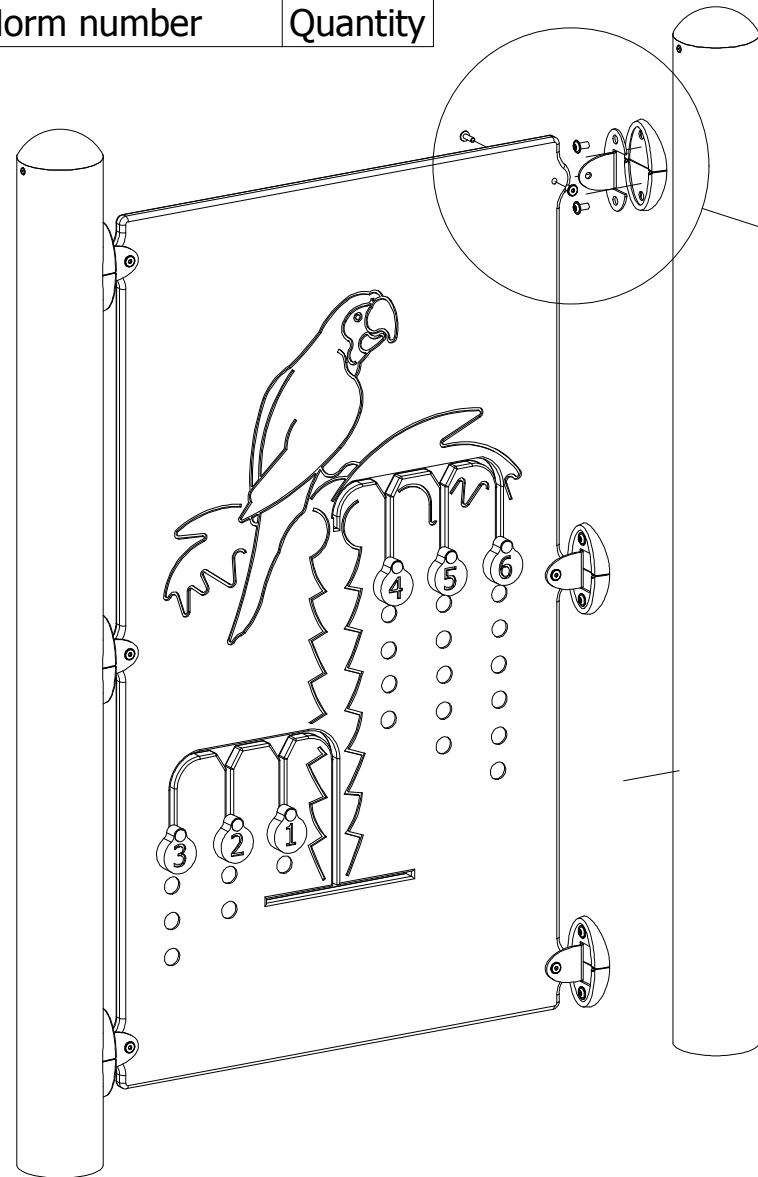

ISO7380\_2\_M6x20\_A2

