



PL	INSTRUKCJA MONTAŻU	Nazwa	Platforma 3	Nr kat.
ENG	ASSEMBLY INSTRUCTIONS	Product	Orbis Set 1118	Cat. no.
DEU	MONTAGEANLEITUNG	Name	Orbis Set 1118 / Metall- Pfosten	Art.-Nr.

1118

1118



Wiek użytkowników Age of users Altersgruppe	Ilość użytkowników Number of users Anzahl der Benutzer	Przeznaczenie urządzenia Purpose of device Bestimmung des Spielgerätes	Zgodność z normą In accordance with the standard Geltende Norm
3-14	10	do zabawy na zewnątrz for outdoor playing zum draußen Spielen	PN-EN 1176-1+A1:2024-03
NOVUM Sp. z o.o. ul. Gnieźnieńska 2a, 12-100 Szczytno		e-mail: kontakt@novum4kids.pl e-mail: export@novum4kids.com	www.novum4kids.pl www.novum4kids.com

UWAGA / WARNING / ACHTUNG:

PL Jeżeli w zestawie występuje zjeżdżalnia, zestaw należy posadowić w taki sposób, aby ślizg zjeżdżalni znajdował się od strony północnej, czyli od strony nienasłonecznionej, aby zapobiegać nadmiernemu nagrzewaniu się ślizgu.

ENG If there is a slide in the set, it should be installed from the north, poorly sunny side to avoid possible hazards (burns) through direct skin contact.

DEU Wenn eine Spielplatzanlage eine Rutsche enthält, sollte diese Anlage so platziert werden, dass die Rutsche sich auf der Nordseite befindet, dh. auf der schattigen Seite, um übermäßige Erwärmung der Rutschbahn zu vermeiden.

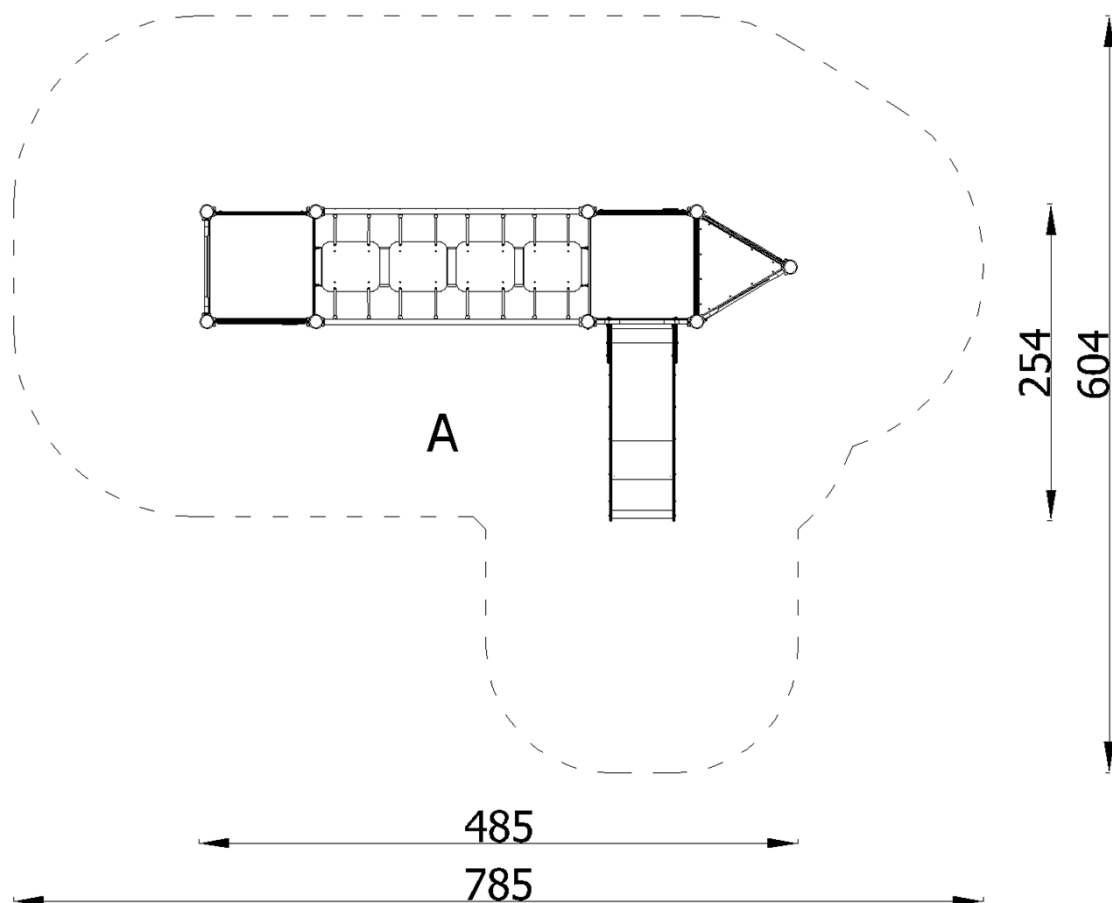

Montaż zgodnie z planem zagospodarowania terenu.
 Installation in accordance with the land development plan.
 Montage gemäß dem Flächennutzungsplan

Bezpieczna nawierzchnia / Safe surface / Safe Oberfläche

Strefa Zone Zone	Max. wysokość upadku Max. fall height Max. Fallhöhe	Pole powierzchni Surface area Fläche	Obwód strefy bezpiecz. Perimeter security zone Umkreis der Fallschutzfläche
A	1,00 m	33,00 m ²	23,50 m
B	-	-	
C	-	-	

Nawierzchnia / Safe surface / Fallschutzbelag			1118
	Materiał Material Material		Min. wysokość warstwy Min. layer thicknesses Min. Schichtöhe
$h < 0,6$ m	Beton / Concrete / Beton Nawierzchnia bitumiczna / Bituminous surfacing / Bituminöse Oberfläche		
$h \leq 1$ m	Gleba / Topsoil / Boden Darrí / Turf / Grasnarbe		
$h \leq 2$ m	Kora / Bark / Borke	20÷80 mm	300
	Wióry / Wood chips / Holzhackschnitzel	5÷30 mm	
	Piasek / Sand / Sand Żwir / Gravel / Kies	0,25÷8 mm	
$h \leq 3$ m	Kora / Bark / Borke	20÷80 mm	400
	Wióry / Wood chips / Holzhackschnitzel	5÷30 mm	
	Piasek / Sand / Sand Żwir / Gravel / Kies	0,25÷8 mm	
$h \leq 3$ m	Nawierzchnia syntetyczna / Synthetic granulates / Synthetische Oberfläche		wg danych producenta acc. to the manufacturer's data nach Angaben des Herstellers

Posadowienie / Foundation / Gründung	1118
--------------------------------------	------

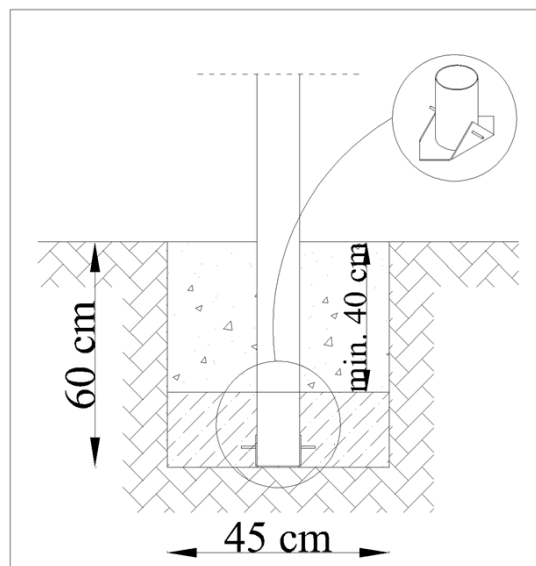

Beton / Concrete / Beton: **C16/20** - **0,41** m³

W celu kontroli fundamentów należy usunąć nawierzchnię bezpieczną / piasek / żwir etc.
 In order to control the foundations, remove the safe surface (sand, gravel, etc.)
 Um die Fundamente zu überprüfen, entfernen Sie den Fallschutzbelag: Sand/ Kies etc.

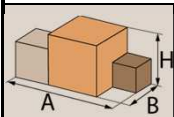
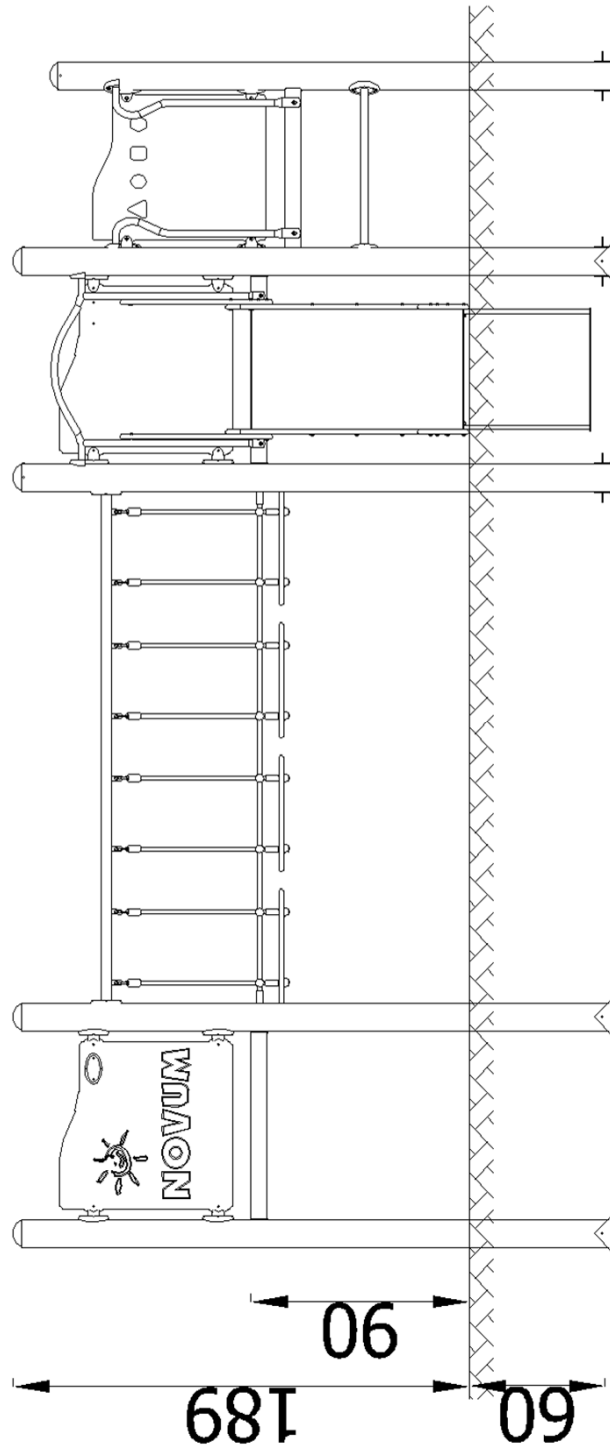

2,54x4,85x1,86
(AxBxH) [m]



274 kg

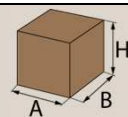

2,1x0,11x0,06
(AxBxH) [m]



42 kg

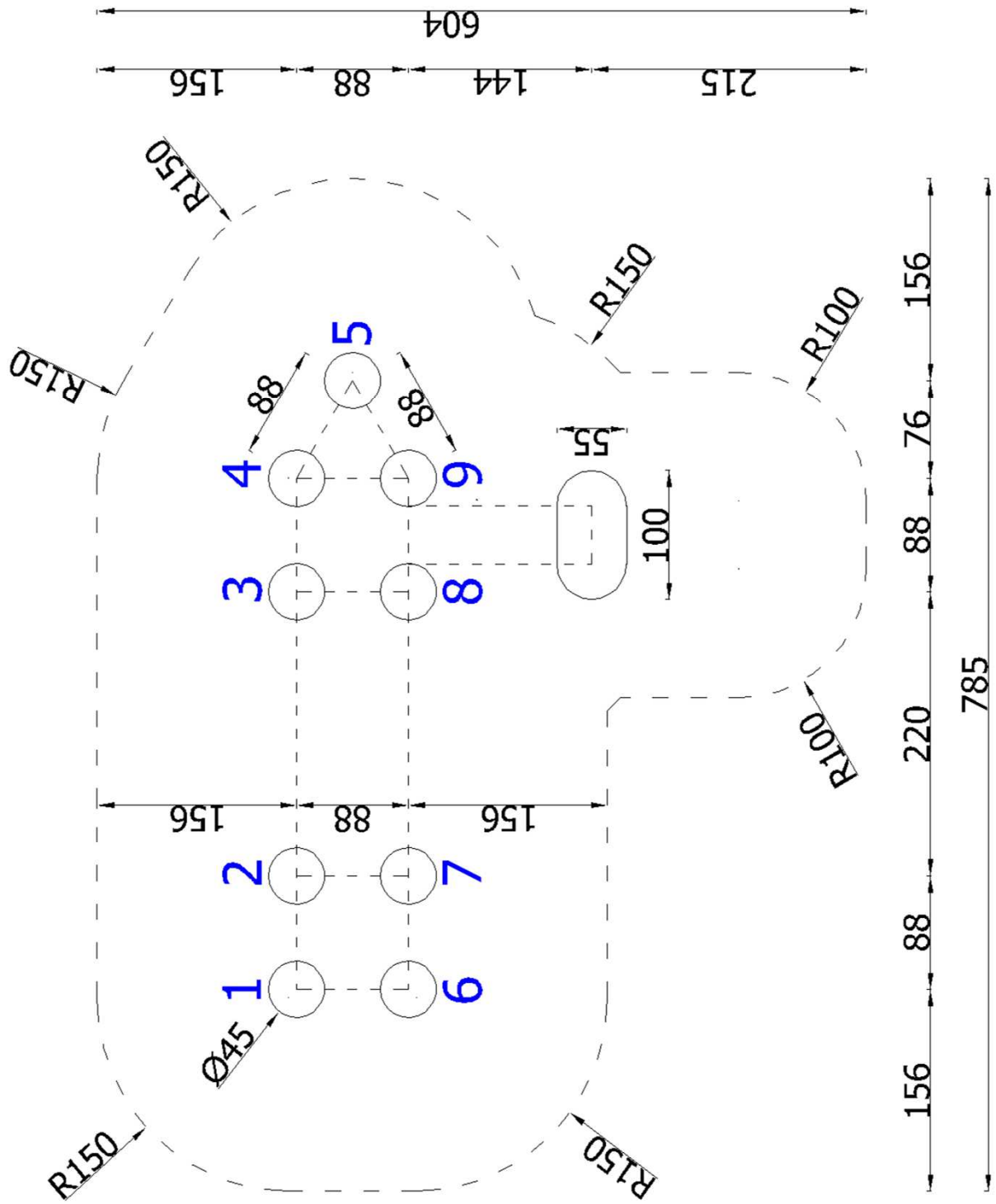

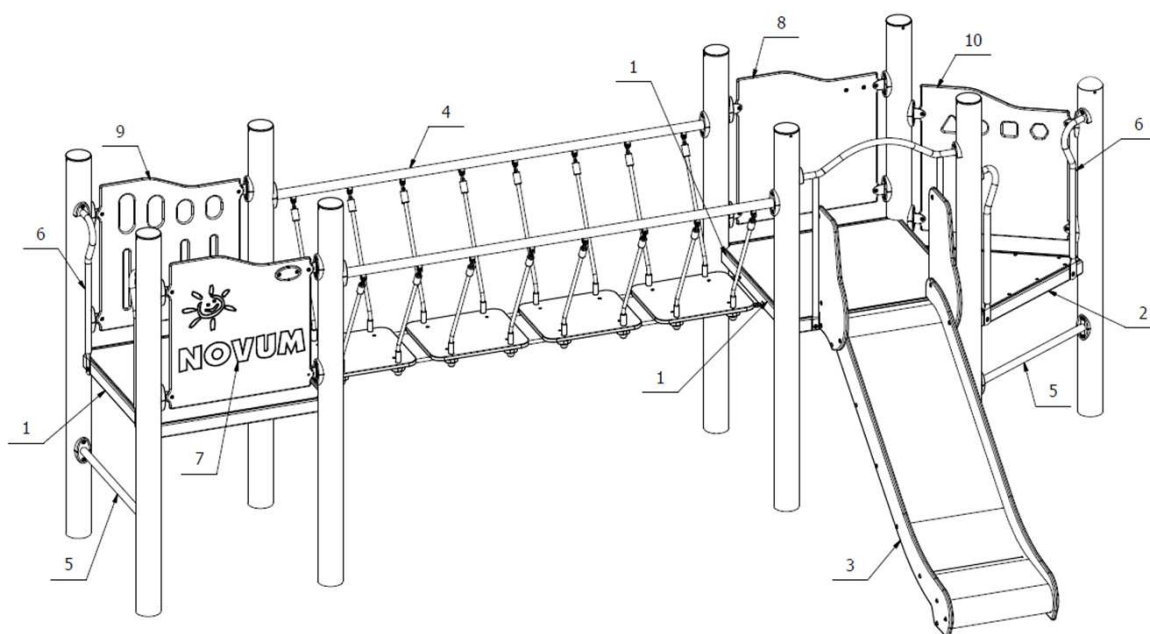

Części zamienne dostępne u producenta.
Stosować klej do gwintów w połączeniach śrubowych.

Spare parts available from the manufacturer.
Use thread glue in screw connections.

Ersatzteile beim Hersteller erhältlich.
Gewindekleber für Schraubverbindungen verwenden.

11	1118/1 - 1118/9	1
10	2403_26_RM_P	1
9	2403_18_RM_L	1
8	2403_01_RM_P	1
7	2403_01_RM_L	1
6	23108_RM	2
5	2335_RM	2
4	22260_RM	1
3	2112_RM	1
2	2072_RM	1
1	2070_RM	2
Lp.	Nr części	Ilość
No.	Art. Nr.	Quantity Anzahl
	Part No.	Teile-Nr

															
								5 m	30 m						
															
2,5 m				60 cm	100 cm										
															
				7 mm								13 mm	17 mm	19 mm	24 mm
															
13 mm	17 mm	19 mm	24 mm	4 mm	5 mm	6 mm	8 mm	T40				T45			
															

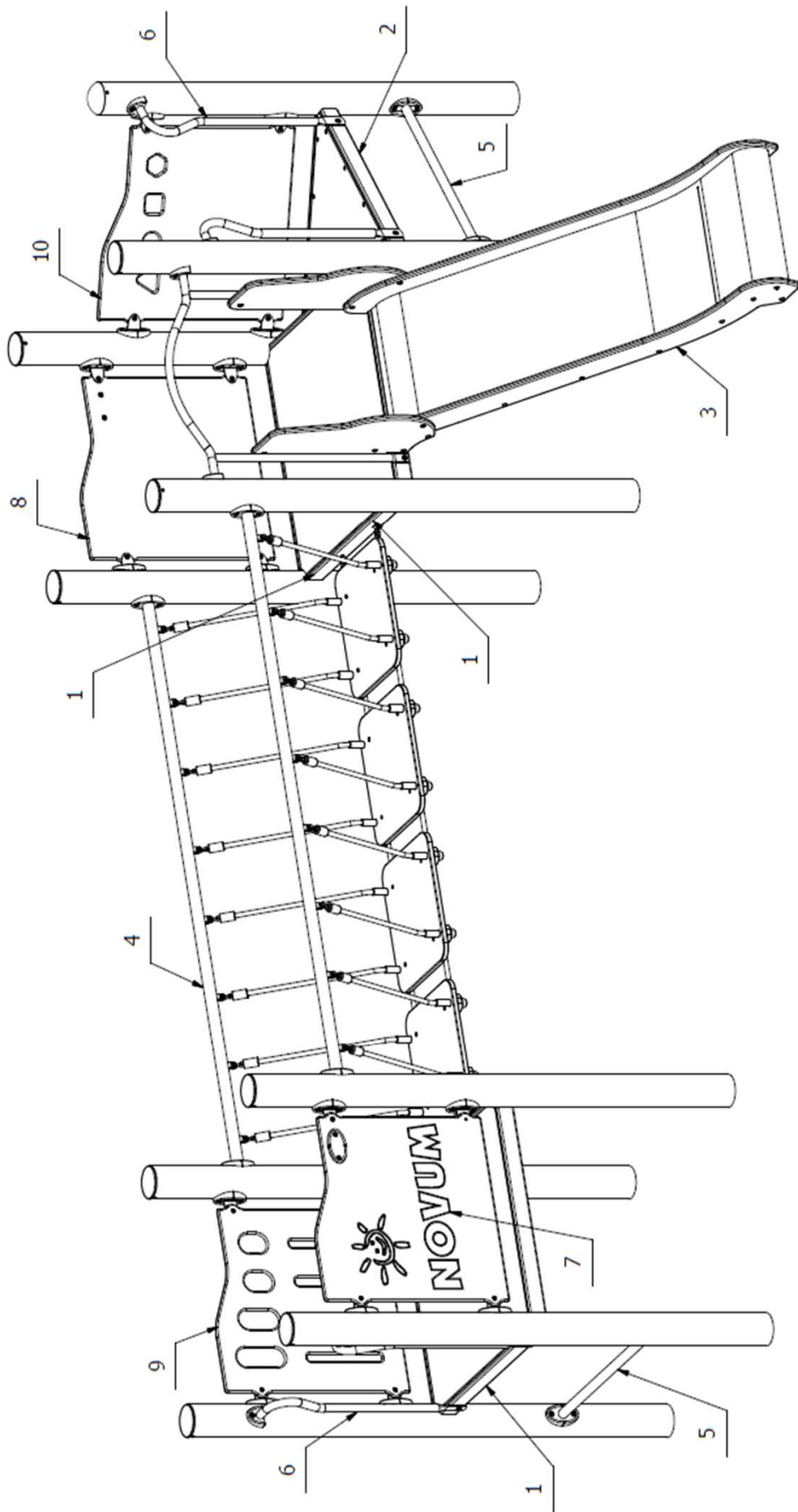

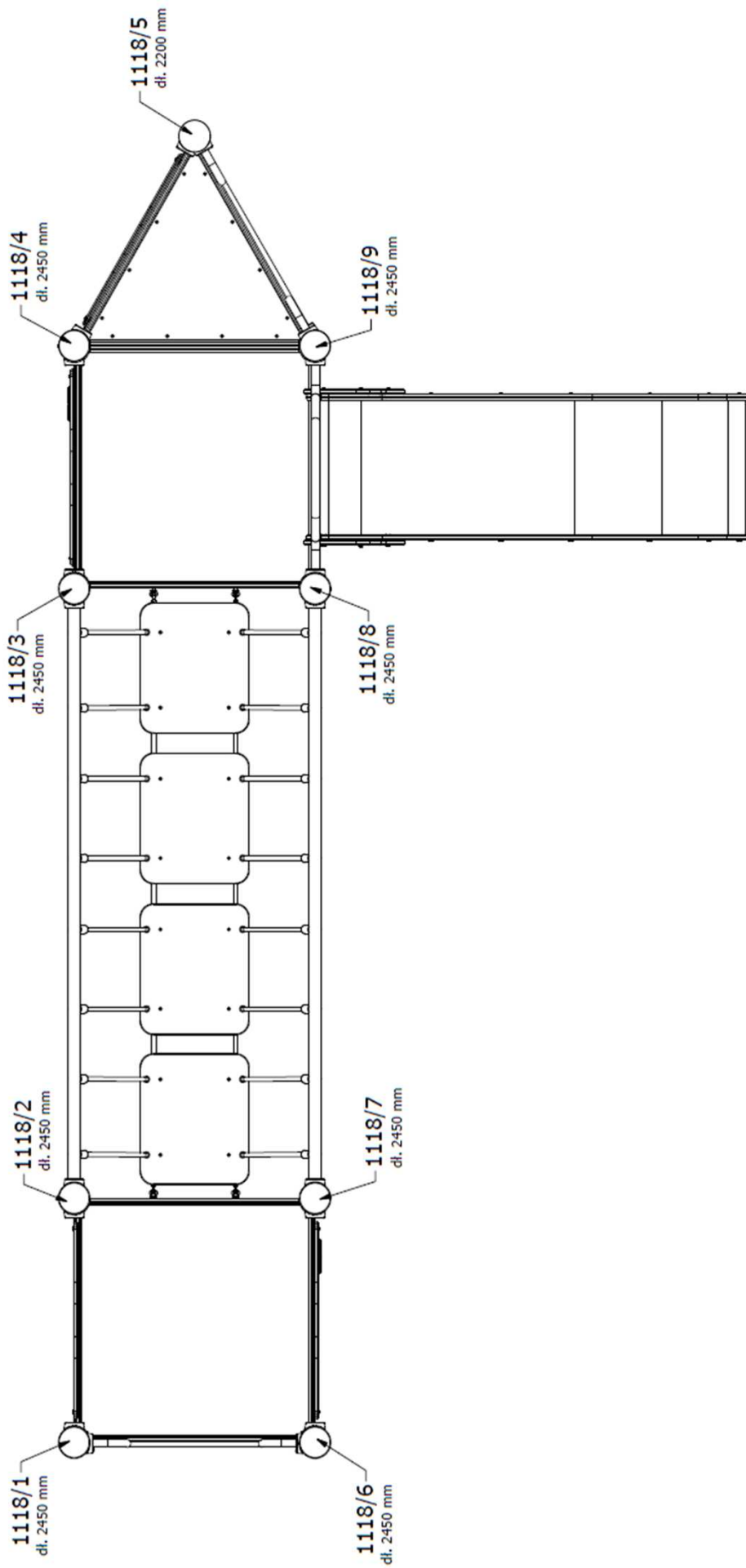

ISO7380_2_M8x16_A2	8
Drawing/Norm number	Quantity

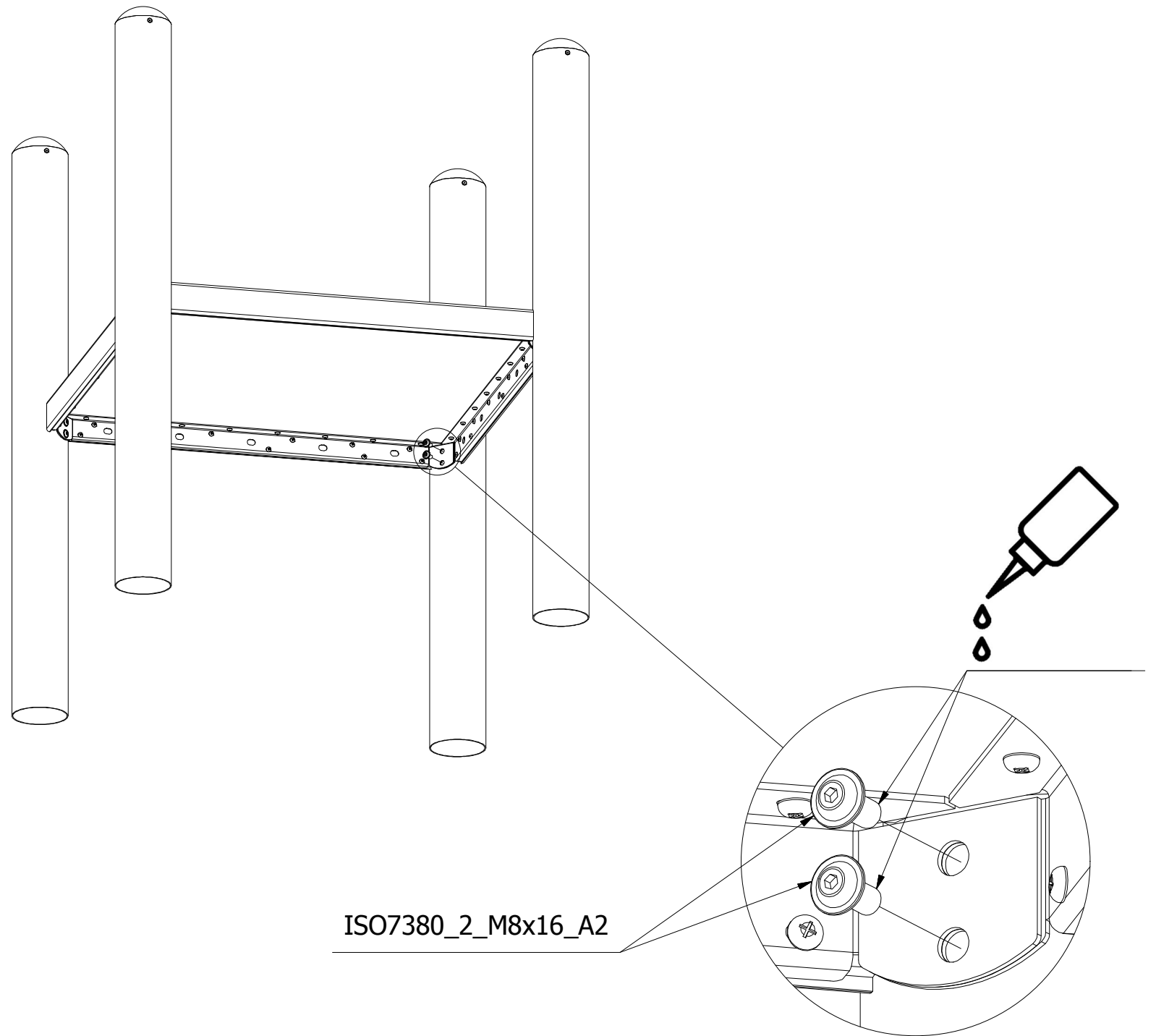
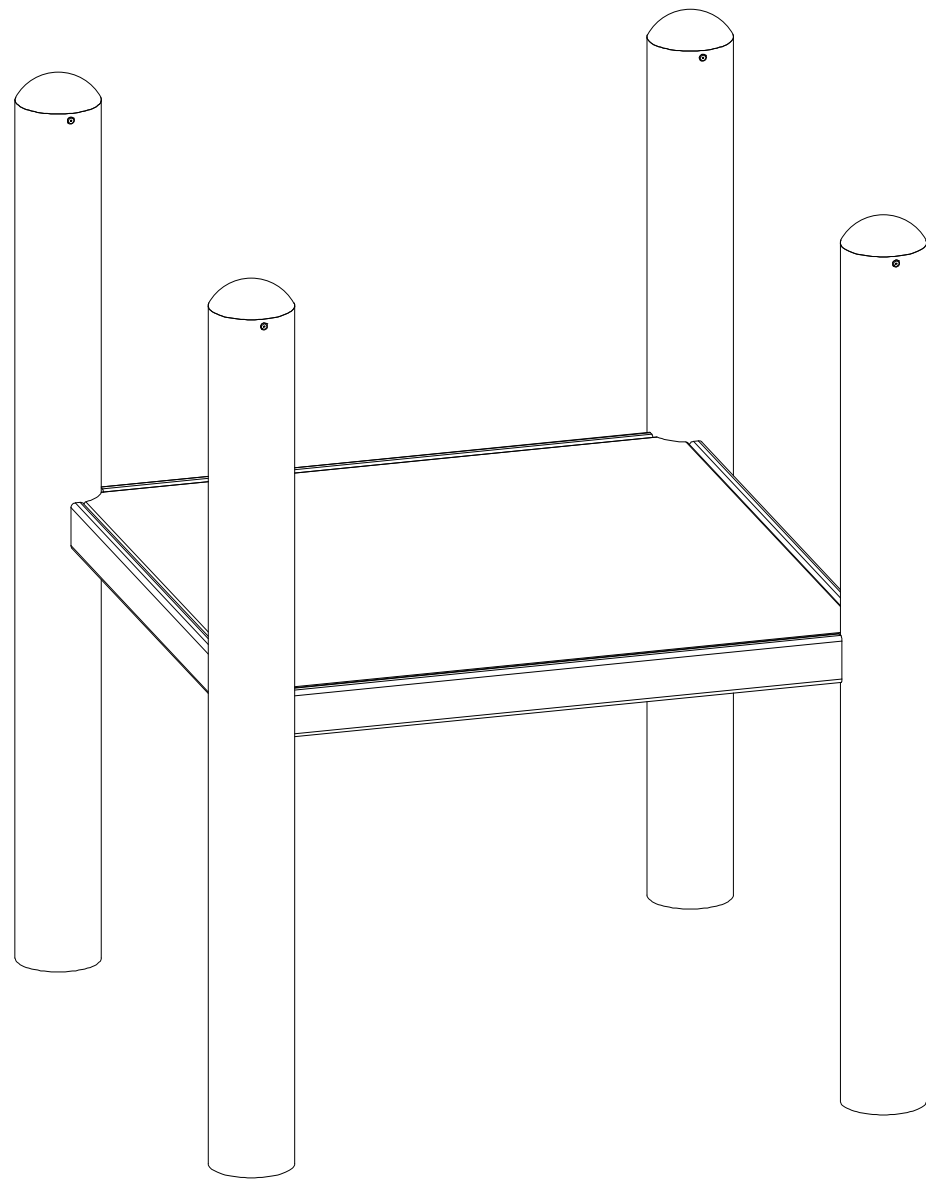

ISO7380_2_M8x16_A2

ISO7380_2_M8x16_A2	6
Drawing/Norm number	Quantity

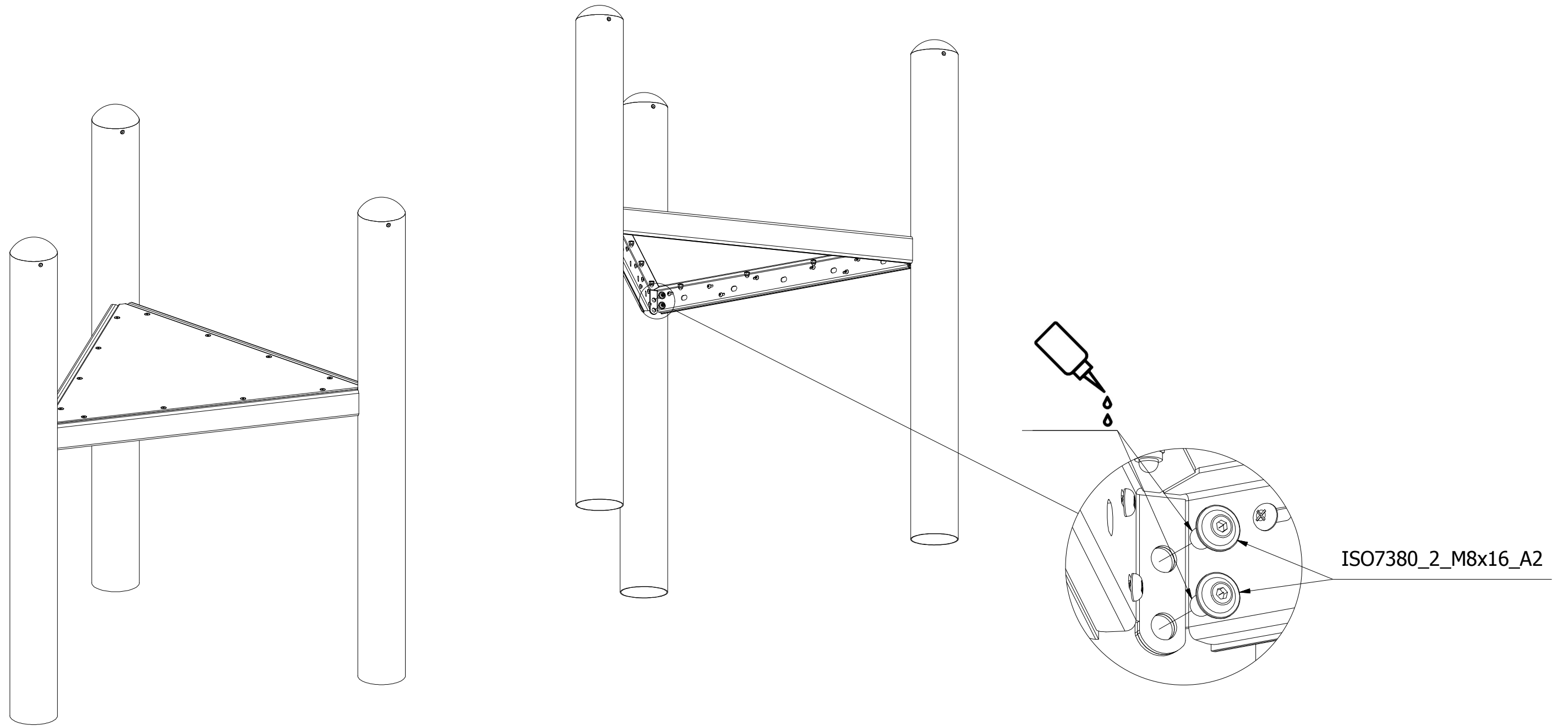

ISO7380_2_M8x16_A2	2
ISO7380_2_M8x40_A2	2
ISO7380_2_M8x35_A2	2
ISO7380_2_M8x30_A2	2
ISO7089_8_A2	4
DIN986_M8_A2	4
8919_001	2
Drawing/Norm number	Quantity

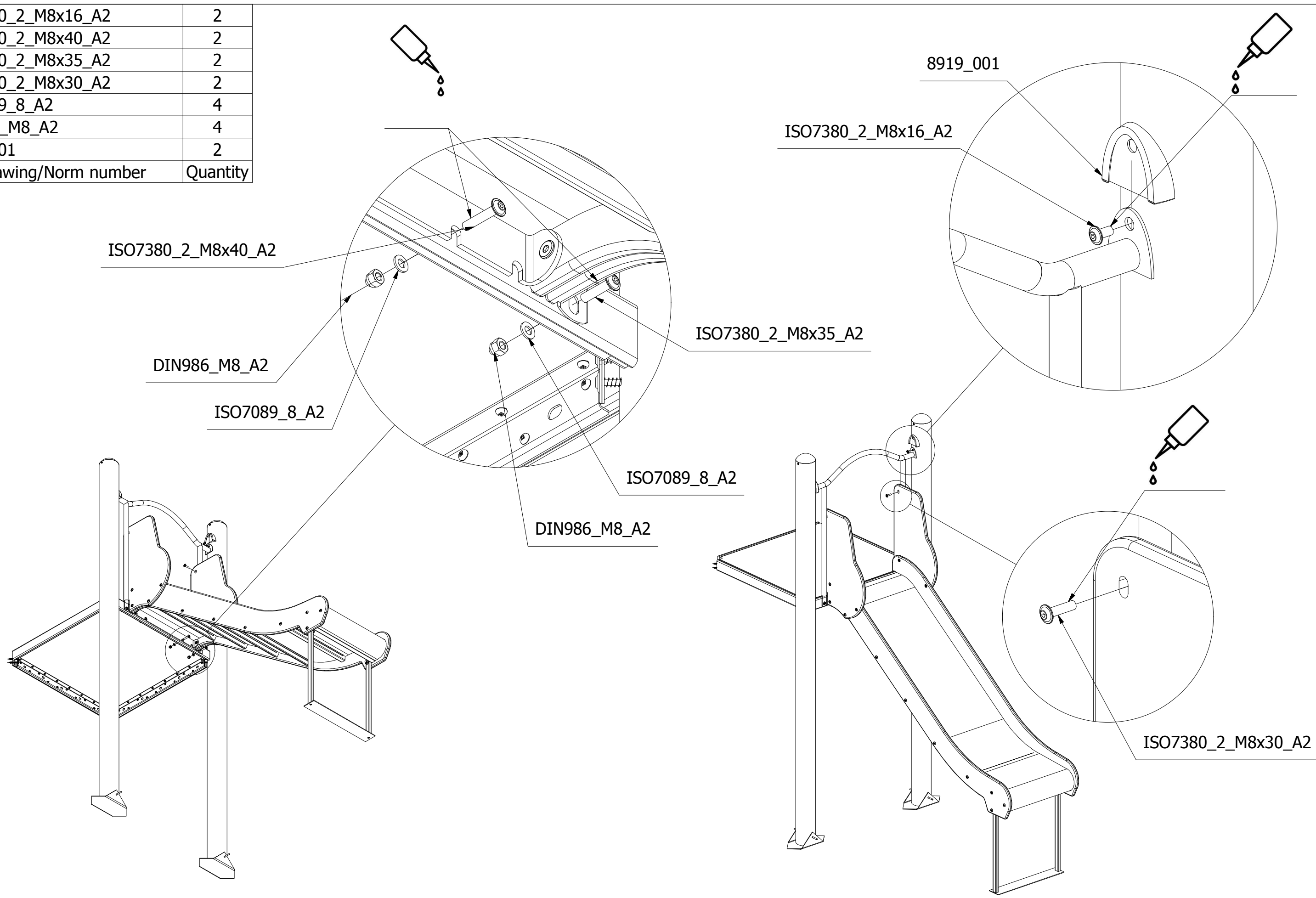

DIN986_M10_A2	4
ISO7089_10_A2	4
ISO7089_8_A2	16
DIN986_M8_A2	16
ISO7380_2_M8x30_A2	24
8919_001	8
Drawing/Norm number	Quantity

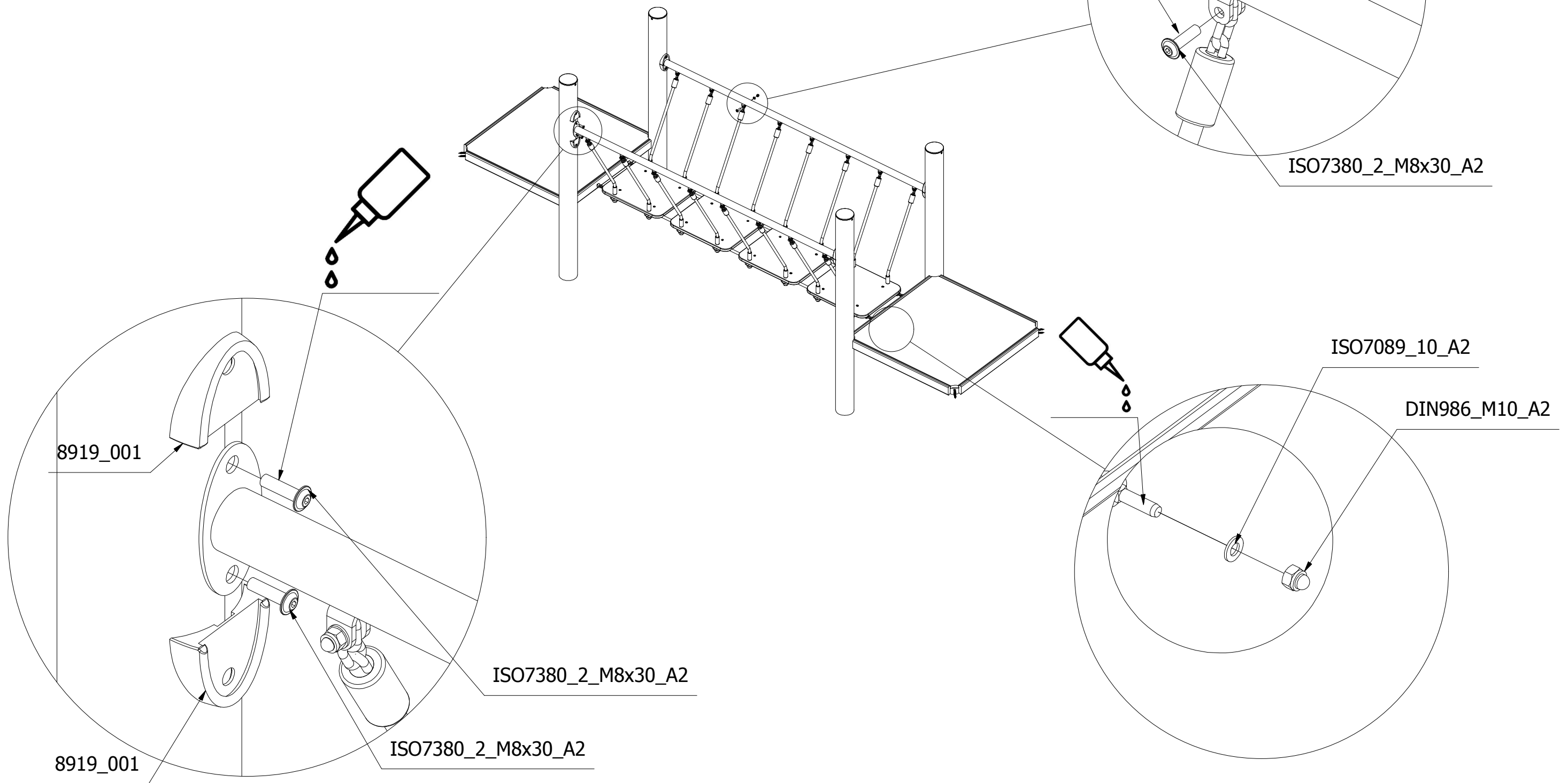

ISO7380_2_M8x16_A2	4
8919_001	4
Drawing/Norm number	Quantity

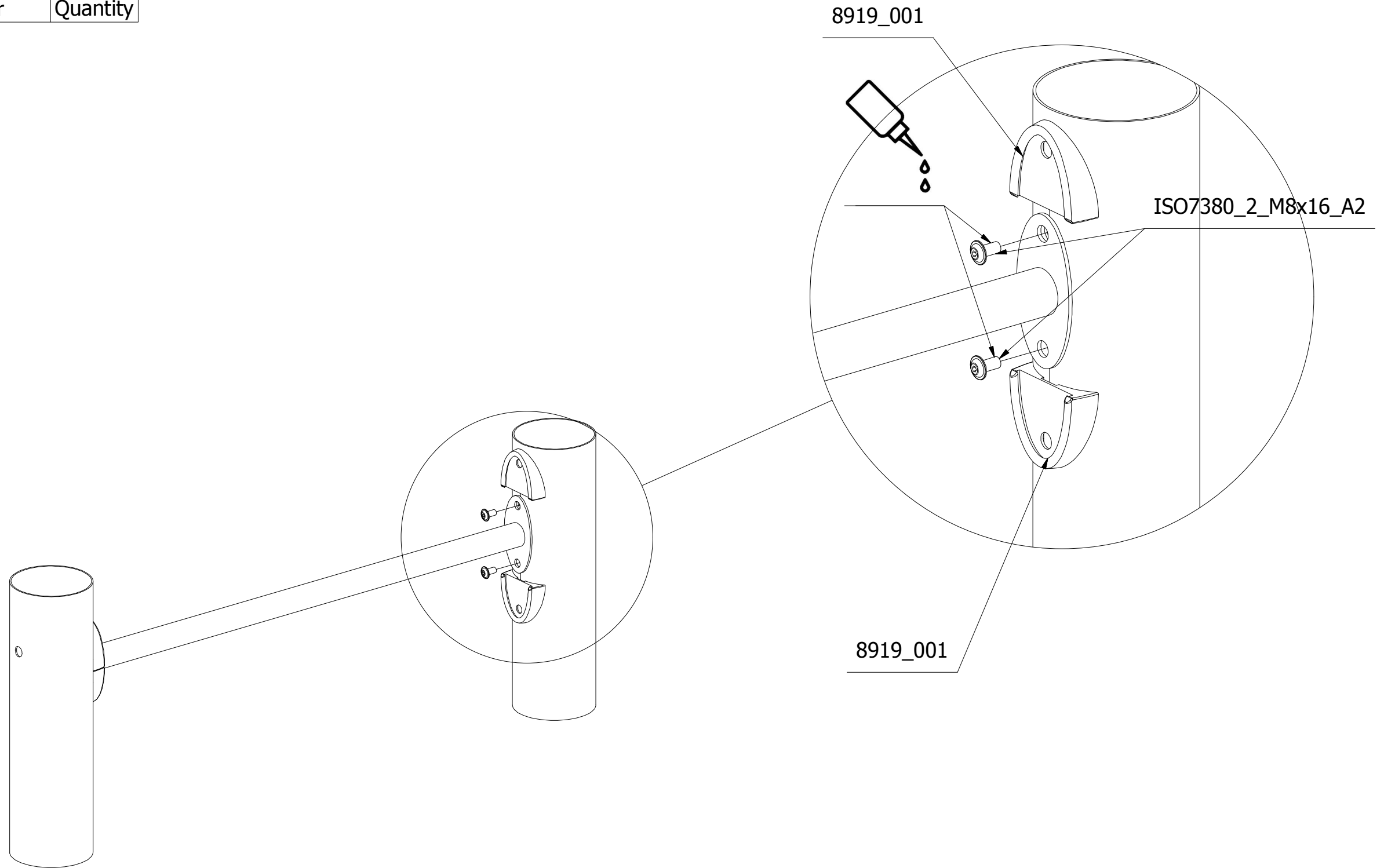

ISO7380_2_M8x16_A2	2
ISO7380_2_M8x35_A2	2
DIN986_M8_A2	2
ISO7089_8_A2	2
8919_001	2
Drawing/Norm number	Quantity

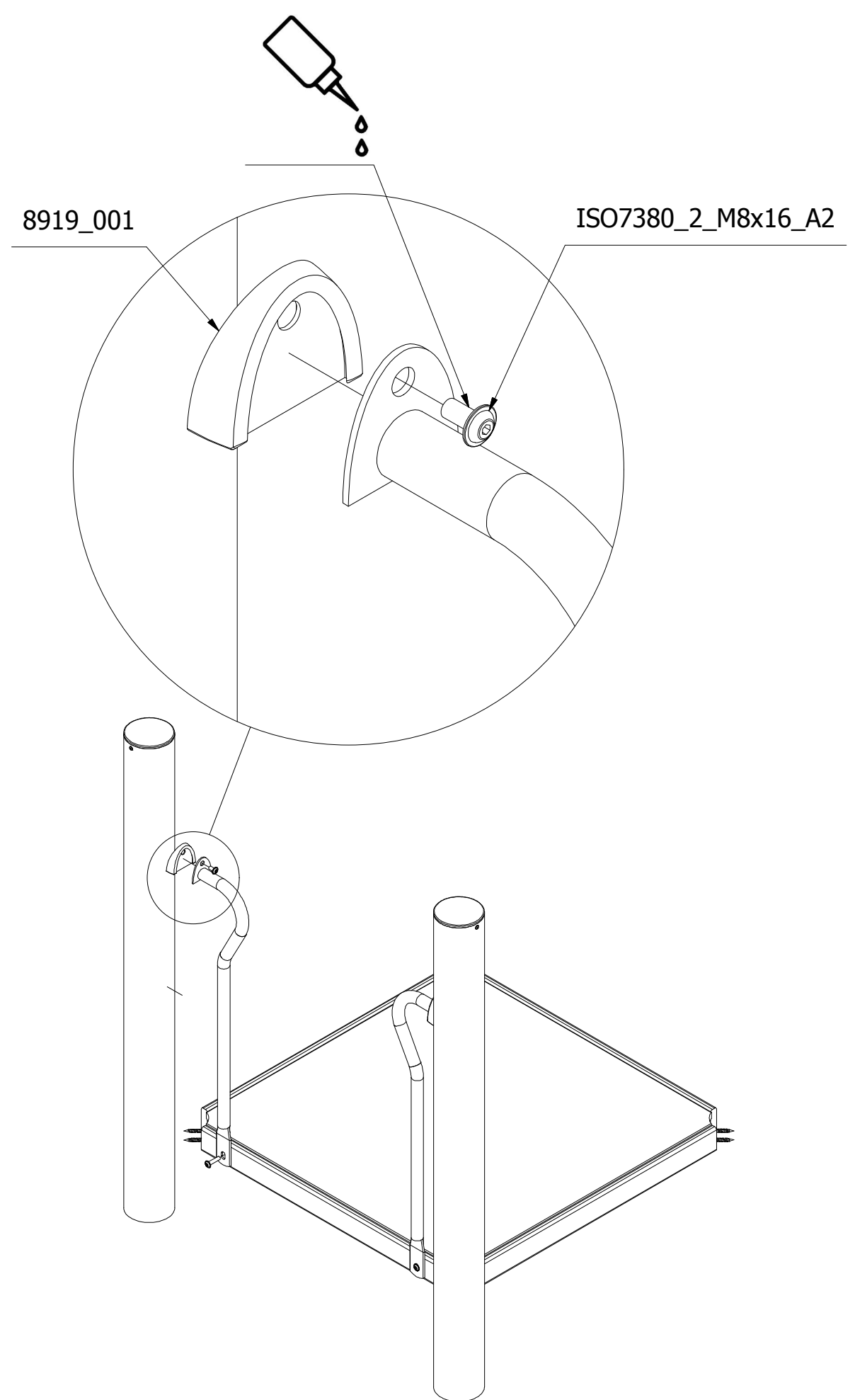
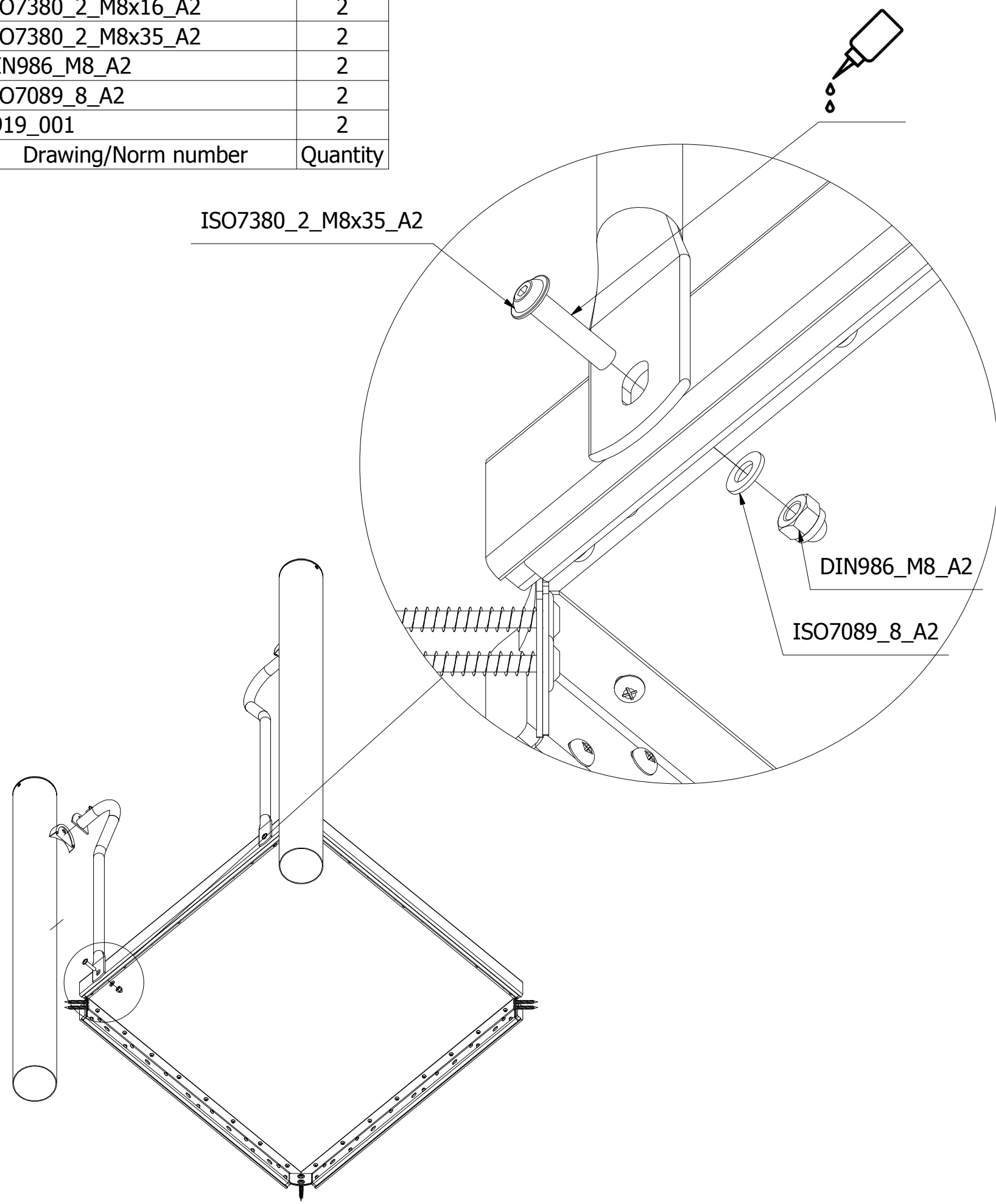

Cat. no.
23108_RM

2024-05-09
1 / 1

ISO7380_2_M8x16_A2	8
B_8801_041	4
ISO7380_2_M6x10_A2	4
8902_007_A2	4
8919_001	8
Drawing/Norm number	Quantity

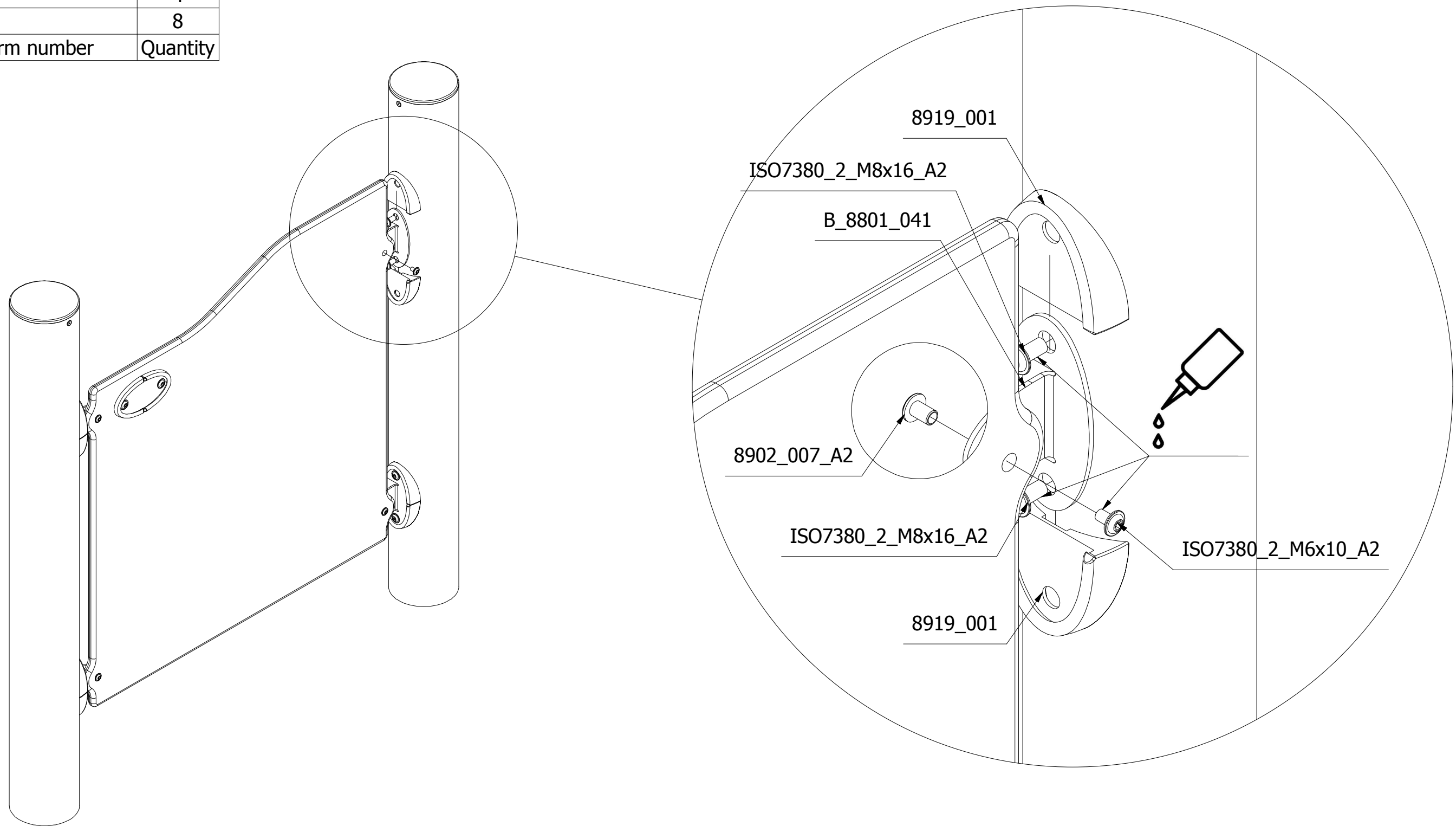

Cat. no.

2403_RM

2024-05-08

1 / 4

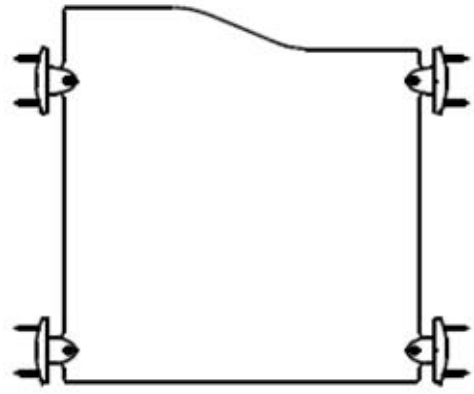

2403_37

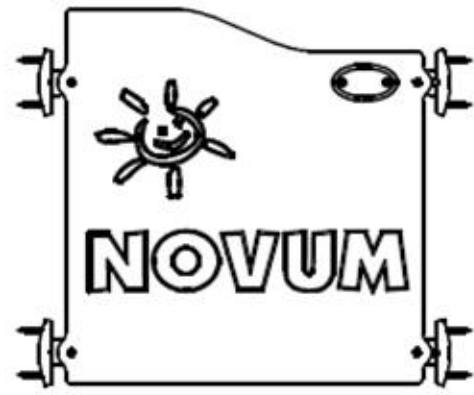

2403_01

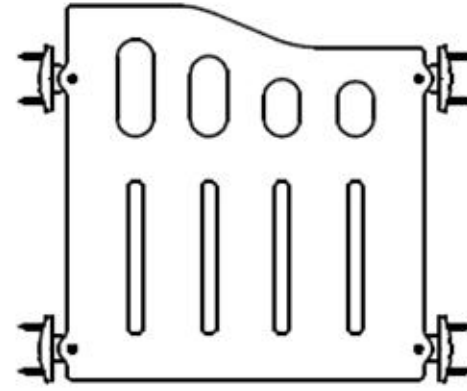

2403_18

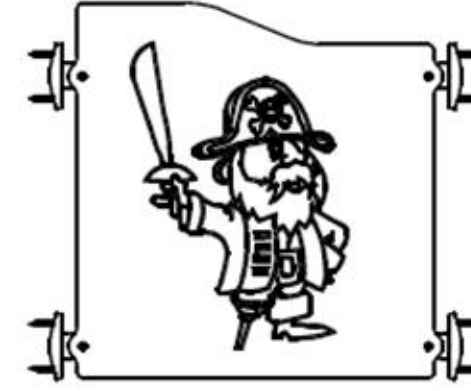

2403_20

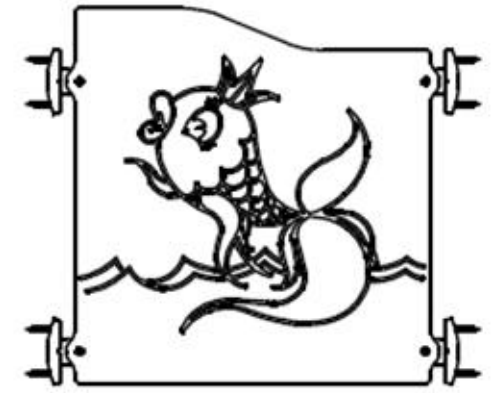

2403_22

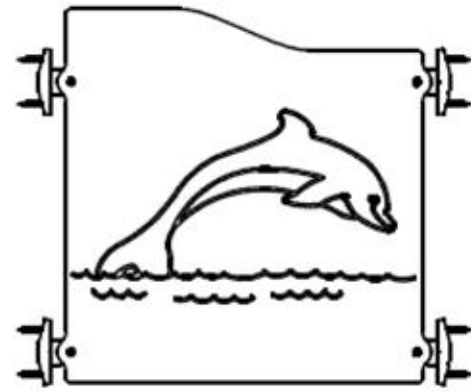

2403_23

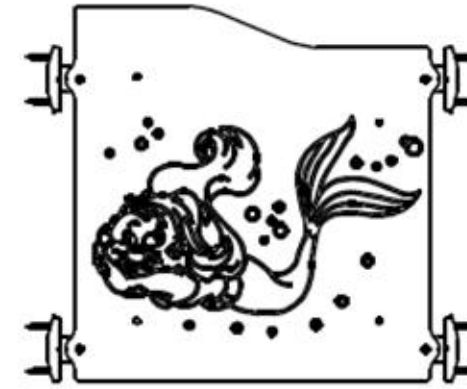

2403_24

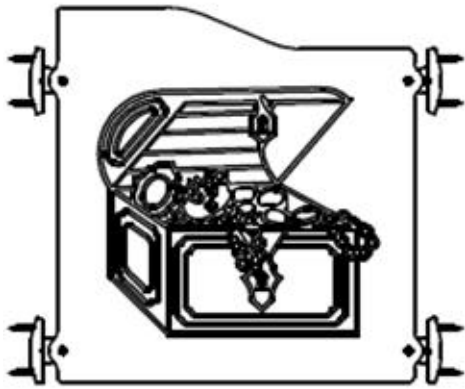

2403_25

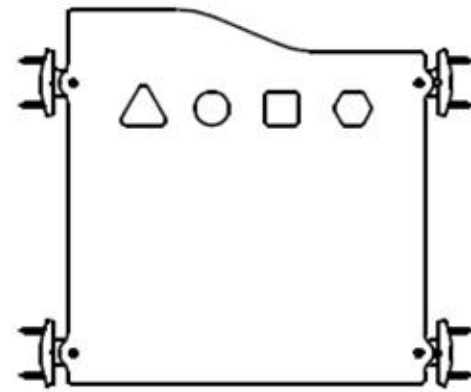

2403_26

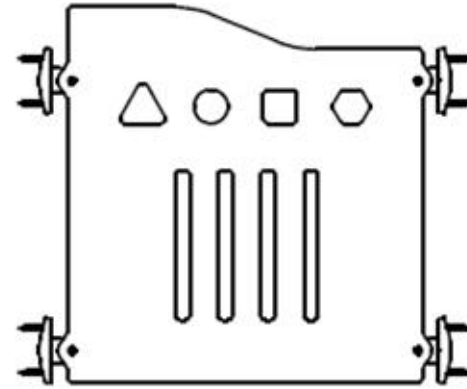

2403_27

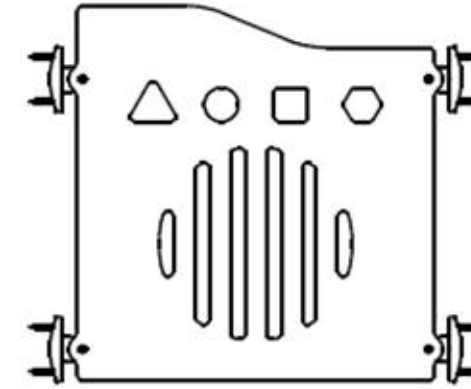

2403_28

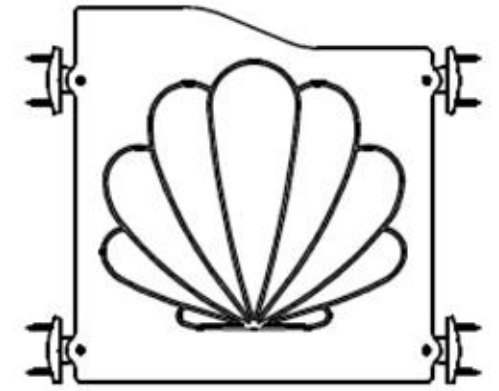

2403_31



2403_10



2403_11

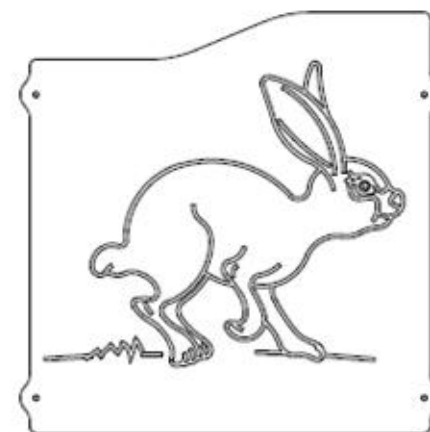

2403_12

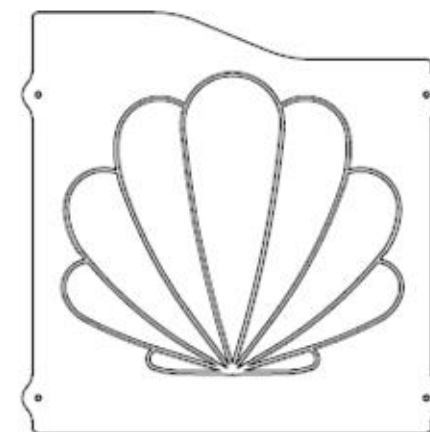

2403_31

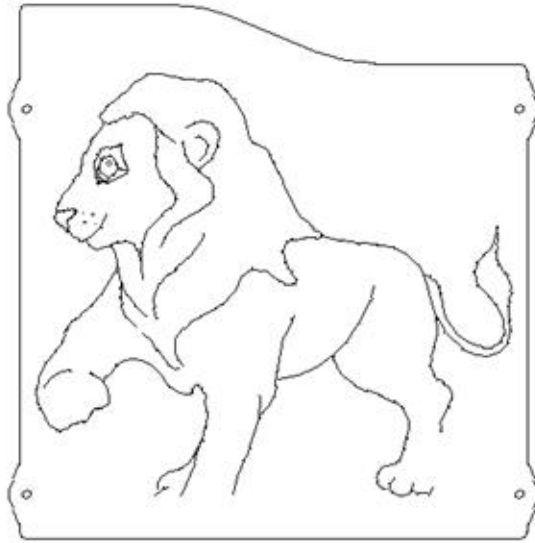

2403_02

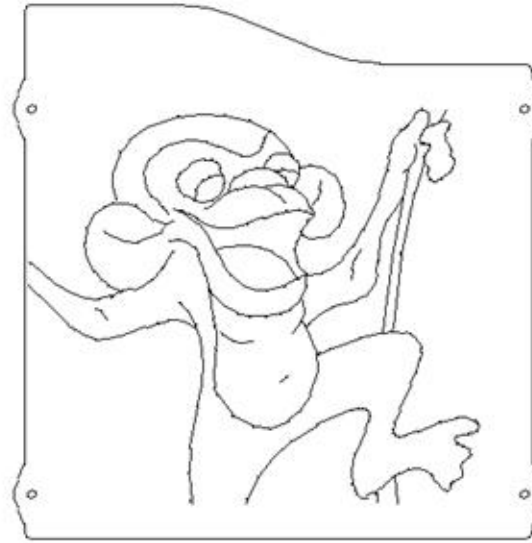

2403_03

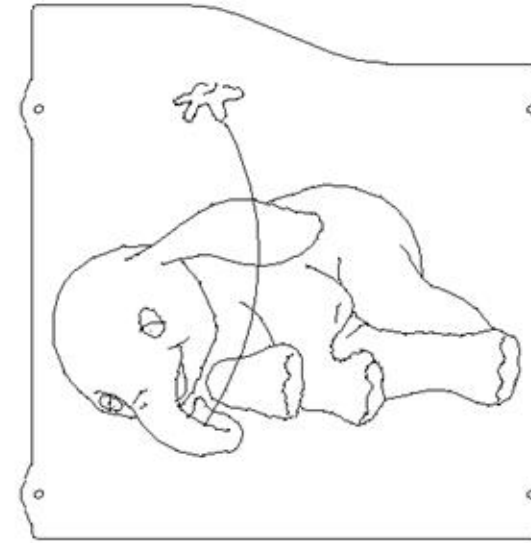

2403_04

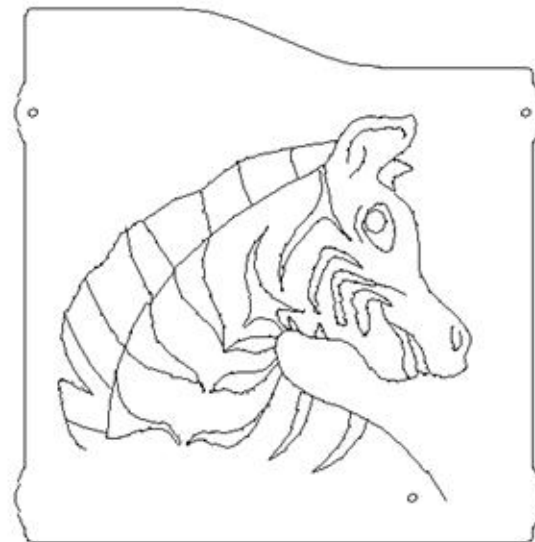

2403_05

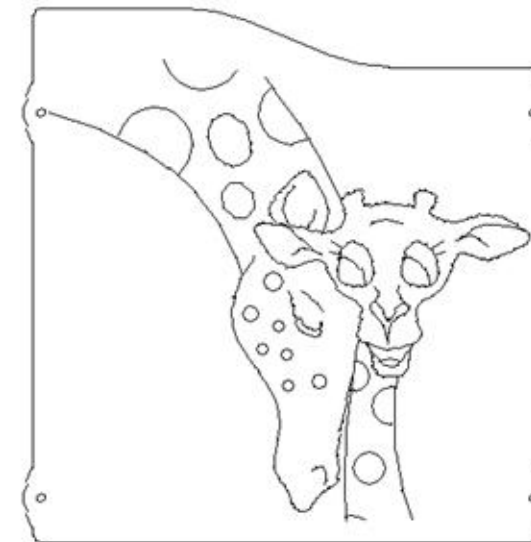

2403_06