

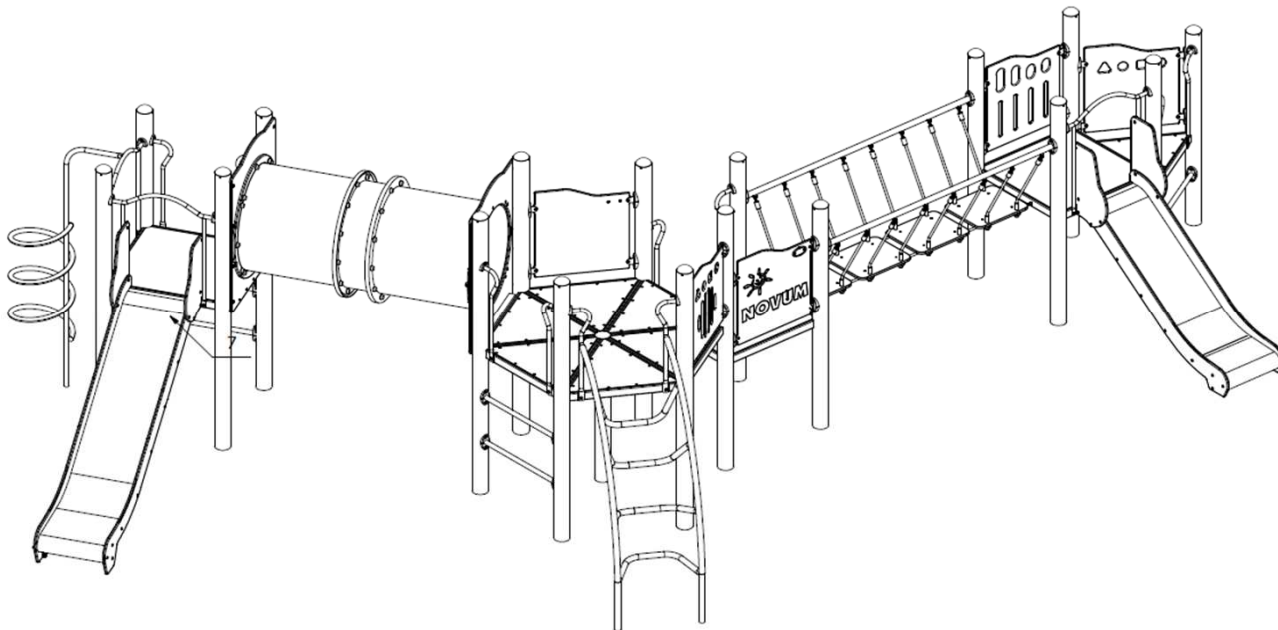

PL	INSTRUKCJA MONTAŻU	Nazwa	Zestaw Orbis	Nr kat.
ENG	ASSEMBLY INSTRUCTIONS	Product	Orbis Set	Cat. no.
DEU	MONTAGEANLEITUNG	Name	Orbis Set	Art.-Nr.
FRA	INSTRUCTIONS D'INSTALLATION	Catégorie	Orbis Set	Référence.

1124

**1124**



Wiek użytkowników Age of users Altersgruppe	Ilość użytkowników Number of users Anzahl der Benutzer Nombre d'utilisateurs	Przeznaczenie urządzenia Purpose of device Bestimmung des Spielgerätes	Zgodność z normą In accordance with the standard Geltende Norm
3 - 14	25	do zabawy na zewnątrz for outdoor playing zum draußen Spielen	PN-EN 1176-1:2017
NOVUM Sp. z o.o. Sp. k. ul. Bolesława Chrobrego 1, 12-100 Szczytno		e-mail: <a href="mailto:biuro@novumedukacja.pl">biuro@novumedukacja.pl</a>	<a href="http://www.novumedukacja.pl">www.novumedukacja.pl</a>
NOVUM Sp. z o.o. Sp. k. ul. Bolesława Chrobrego 1, 12-100 Szczytno		e-mail: <a href="mailto:eksport@novumgrom.com">eksport@novumgrom.com</a>	<a href="http://www.novum4kids.com">www.novum4kids.com</a>

**UWAGA / WARNING / ACHTUNG / ATTENTION:**

**PL** Jeżeli w zestawie występuje zjeżdżalnia, zestaw należy posadowić w taki sposób, aby ślizg zjeżdżalni znajdował się od strony północnej, czyli od strony nienasłonecznionej, aby zapobiegać nadmiernemu nagrzewaniu się ślizgu.

**ENG** If there is a slide in the set, it should be installed from the north, poorly sunny side to avoid possible hazards (burns) through direct skin contact.

**DEU** Wenn eine Spielplatzanlage eine Rutsche enthält, sollte diese Anlage so platziert werden, dass die Rutsche sich auf der Nordseite befindet, dh. auf der schattigen Seite, um übermäßige Erwärmung der Rutschbahn zu vermeiden.

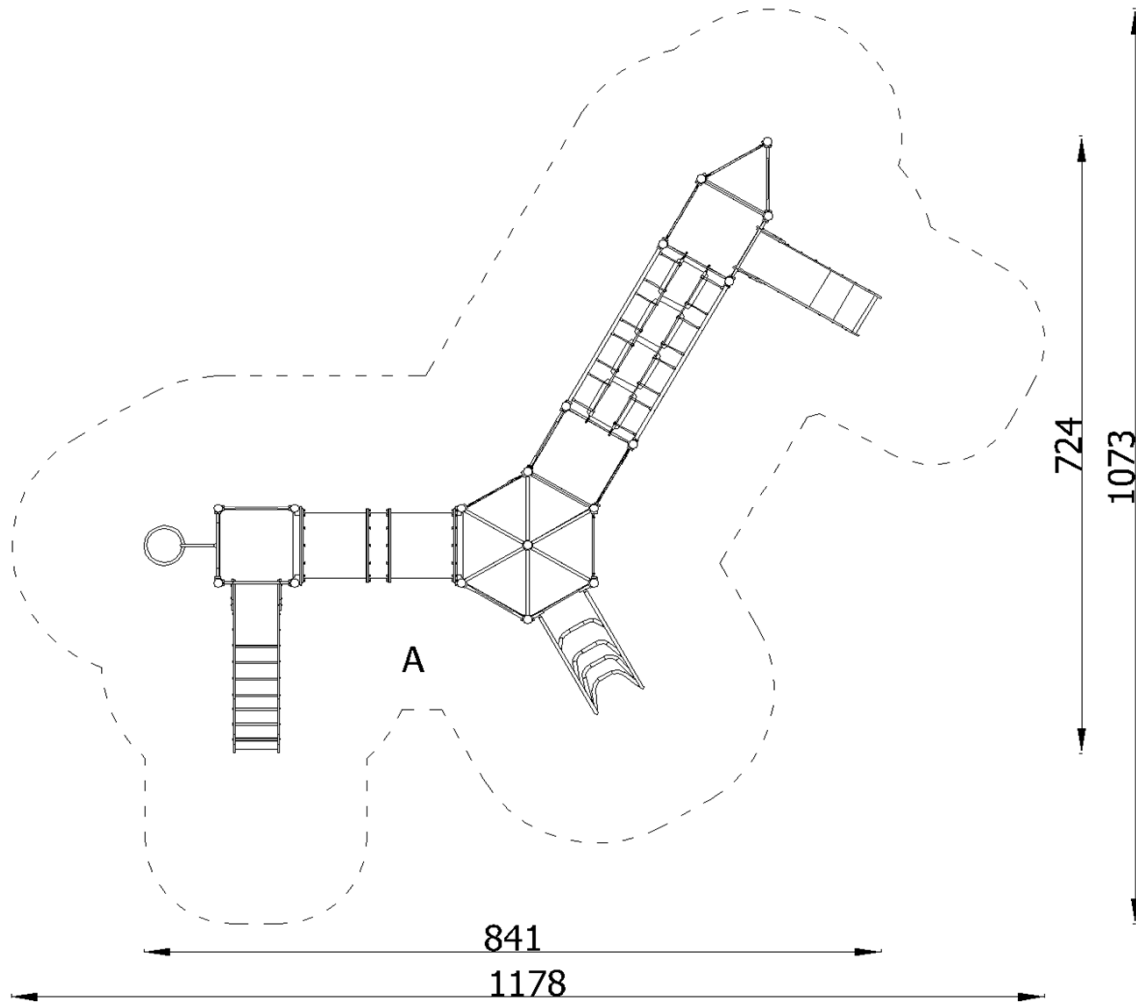

Montaż zgodnie z planem zagospodarowania terenu.  
 Installation in accordance with the land development plan.  
 Montage gemäß dem Flächennutzungsplan

Bezpieczna nawierzchnia / Safe surface / Safe Oberfläche / Surface sûre

Strefa Zone Zone Zone	Max. wysokość upadku Max. fall height Max. Fallhöhe Max. hauteur de chute	Pole powierzchni Surface area Fläche Surface	Obwód strefy bezpiecz. Perimeter security zone Umkreis der Fallschutzfläche Zone de périmètre de sé.
A	1,20 m	63,50 m <sup>2</sup>	40,00 m
B	-	-	
C	-	-	

Nawierzchnia / Safe surface / Fallschutzbelag / fr

1124



Materiał  
Material  
Material

Min. wysokość warstwy  
Min. layer thicknesses  
Min. Schichtöhe

h<0,6 m

Beton / Concrete / Beton  
Nawierzchnia bitumiczna / Bituminous surfacing / Bituminöse Oberfläche

h<1 m

Gleba / Topsoil / Boden  
Darń / Turf / Grasnarbe

h<2 m

Kora / Bark / Borke

20÷80 mm

Wióry / Wood chips / Holzackschnitzel

5÷30 mm

Piasek / Sand / Sand  
Żwir / Gravel / Kies

0,25÷8 mm

300

h<3 m

Kora / Bark / Borke

20÷80 mm

Wióry / Wood chips / Holzackschnitzel

5÷30 mm

Piasek / Sand / Sand  
Żwir / Gravel / Kies

0,25÷8 mm

400

h<3 m

Nawierzchnia syntetyczna / Synthetic granulates / Synthetische Oberfläche

wg danych producenta  
acc. to the manufacturer's data  
nach Angaben des Herstellers

Posadowienie / Foundation / Gründung / Fondation

1124

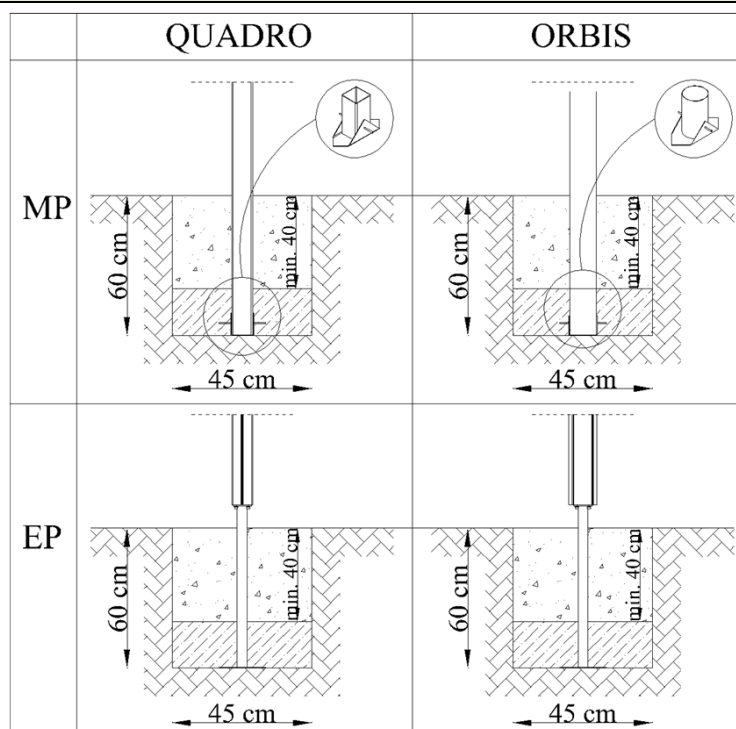

Beton / Concrete / Beton: **C16/20** - **0,95** m<sup>3</sup>

W celu kontroli fundamentów należy usunąć nawierzchnię bezpieczną / piasek / żwir etc.  
In order to control the foundations, remove the safe surface (sand, gravel, etc.)  
Um die Fundamente zu überprüfen, entfernen Sie den Fallschutzbelag: Sand/ Kies etc.

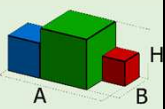
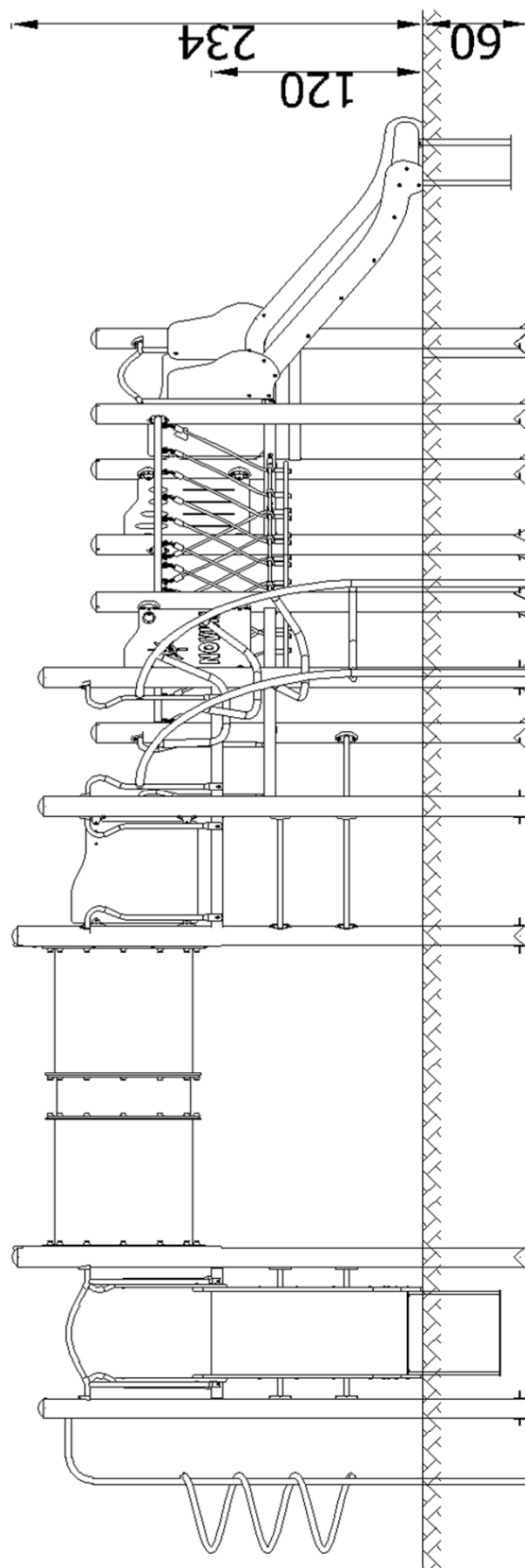

7,24x8,41x2,34  
(AxBxH) [m]

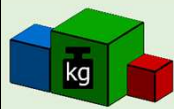

670 kg

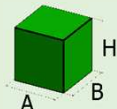

2,9x0,3x0,13  
(AxBxH) [m]



49 kg

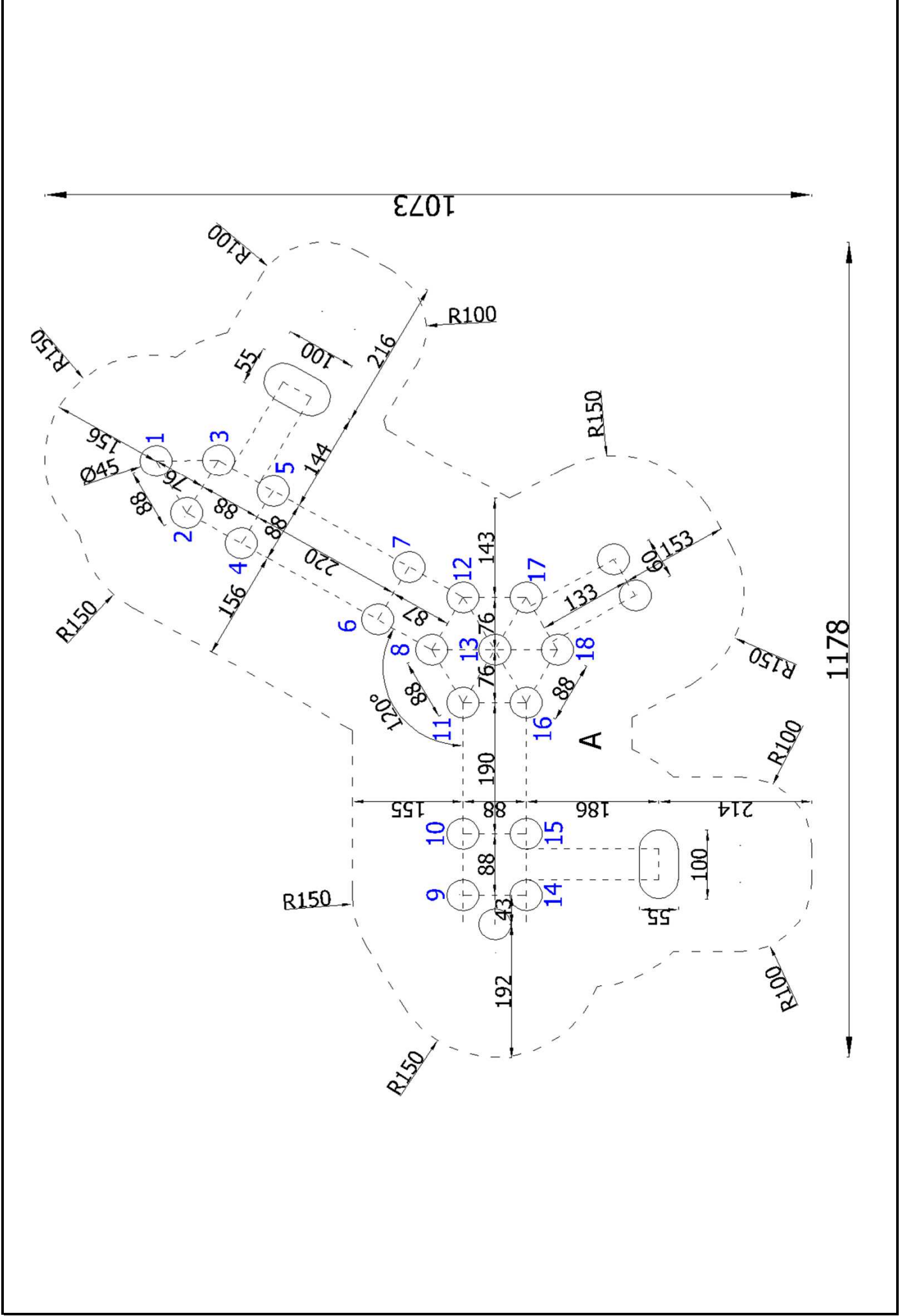

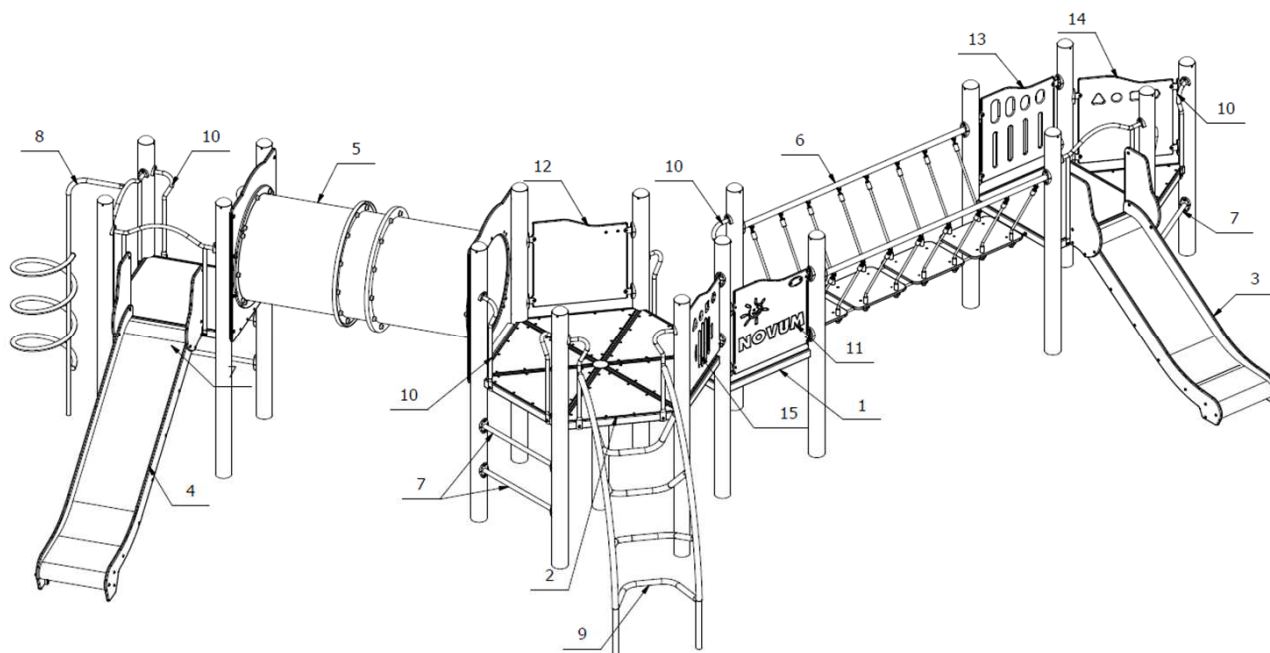

Części zamienne dostępne u producenta. Stosować klej do gwintów w połączeniach śrubowych.  
Spare parts available from the manufacturer. Use thread glue in screw connections.  
Ersatzteile beim Hersteller erhältlich. Gewindekleber für Schraubverbindungen verwenden.

16	Komplet rur z elementem kotwiącym zestawu 1124 - ocynk		1124/1 - 1124/18	1			
15	Zabezpieczenie Ażurowe Koło		2403_28_RM_L	1			
14	Zabezpieczenie Ażurowe Figury		2403_26_RM_P	1			
13	Zabezpieczenie Ażurowe		2403_18_RM_P	1			
12	Zabezpieczenie NOVUM		2403_01_RM_P	1			
11	Zabezpieczenie NOVUM		2403_01_RM_L	1			
10	Zwężka		23108_RM	4			
9	Wejście łukowe 120		23104_RM	1			
8	Wejście spiralne 120		23103_RM	1			
7	Stopień z podwójnymi wypraskami		2335_RM	6			
6	Pomost linowy z prostokątami - prostokąty na linach		22260_RM	1			
5	Pomost tunelowy tuba		2207_RM	1			
4	Zjeżdżalnia 120		2113_RM	1			
3	Zjeżdżalnia 90		2112_RM	1			
2	Podest trójkątny		2072_RM	7			
1	Podest Orbis		2070_RM	3			
Lp. Art. Nr.	No. Rep.	Nazwa części Teilename	Part name Nom de la pièce	Nr części Teile-Nr	Part No. Partie No.	Ilość Anzahl	Quantity Nombre

															
								5 m	30 m						
															
2,5 m				60 cm	100 cm										
															
				7 mm								13 mm	17 mm	19 mm	24 mm
															
13 mm	17 mm	19 mm	24 mm	4 mm	5 mm	6 mm	8 mm	T40				T45			
															

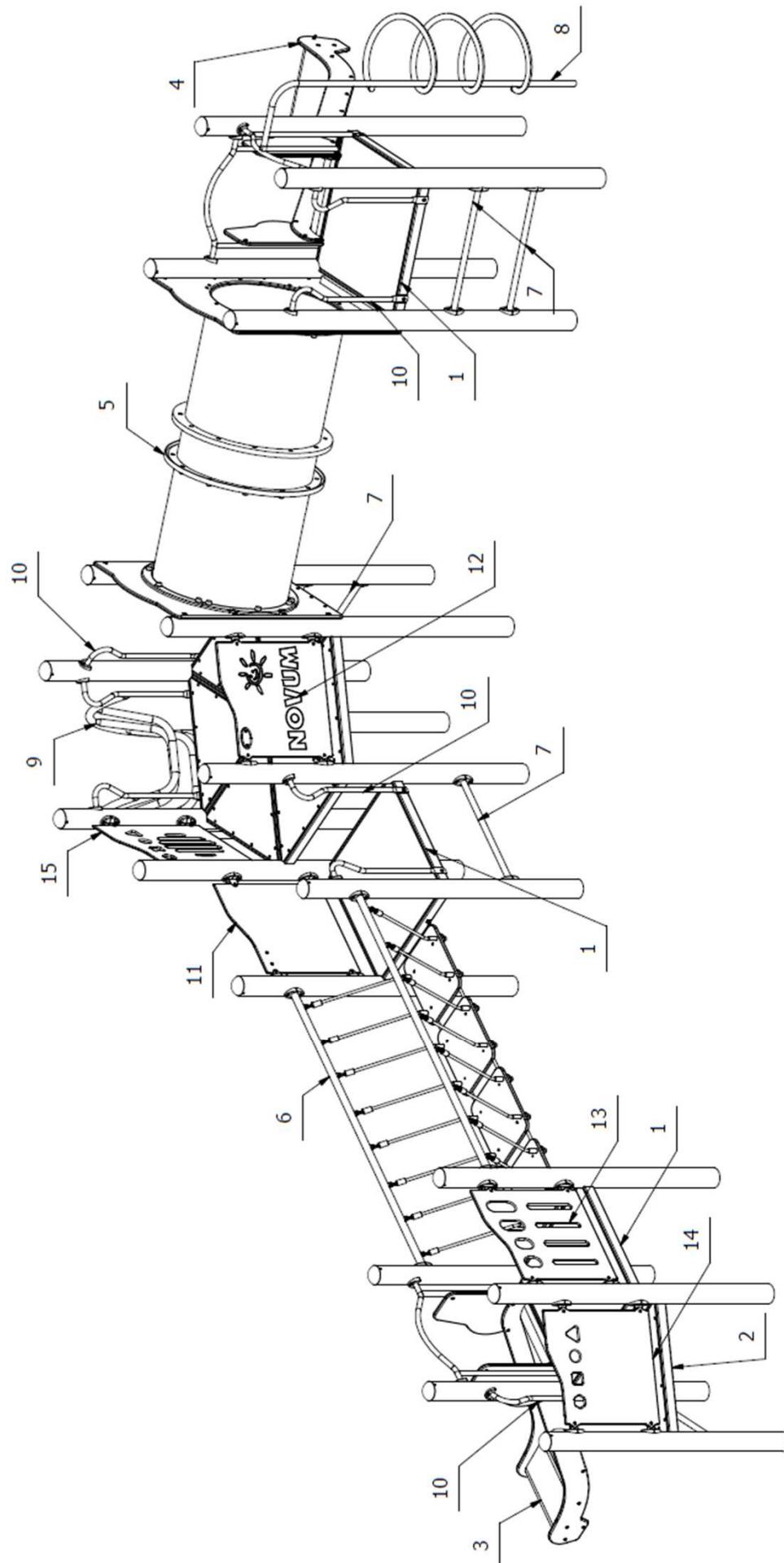

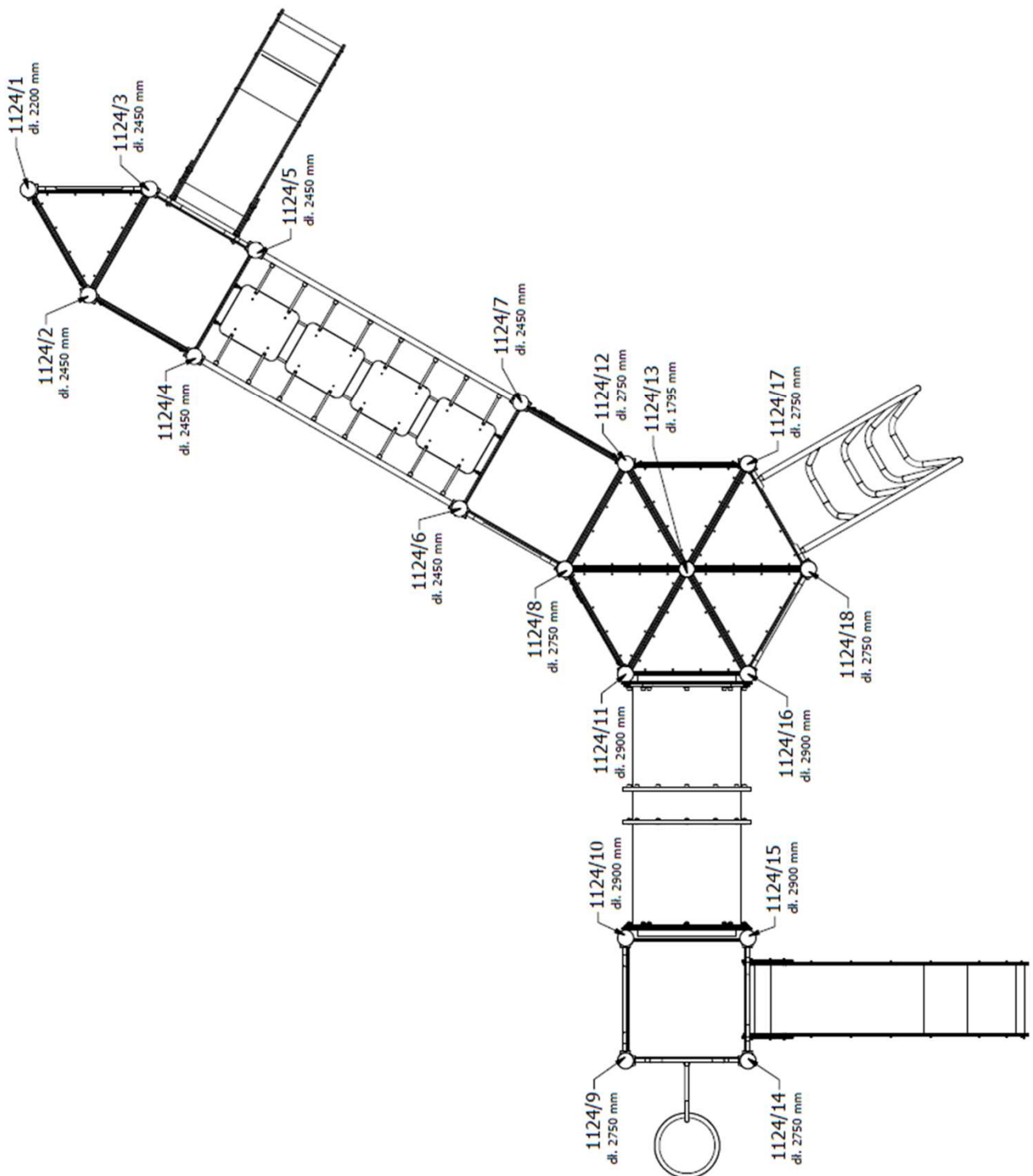

ISO7380_2_M8x16_A2	8
Nr Rys./Normy	Ilość

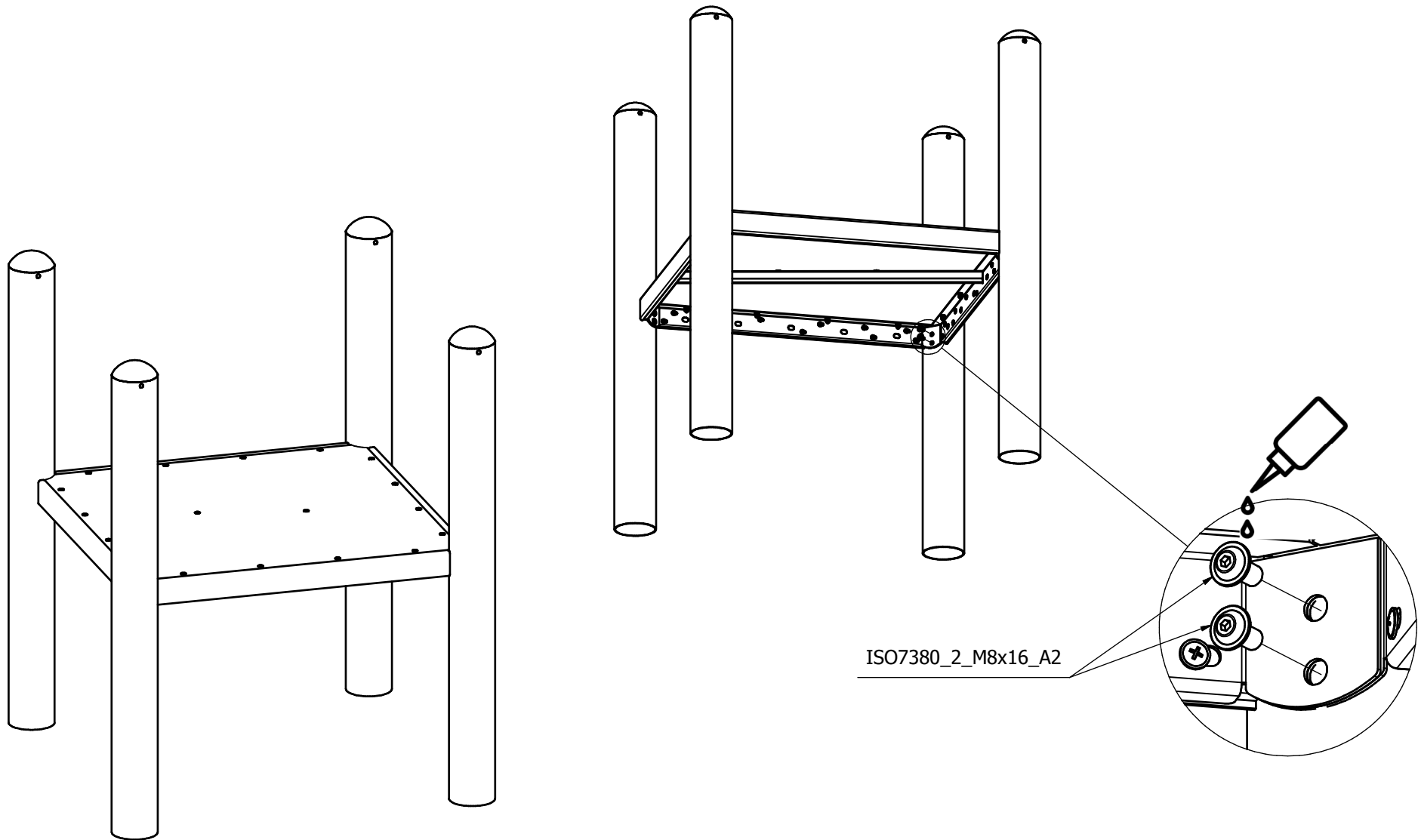

ISO7380\_2\_M8x16\_A2

ISO7380_2_M8x16_A2	6
Nr Rys./Normy	Ilość

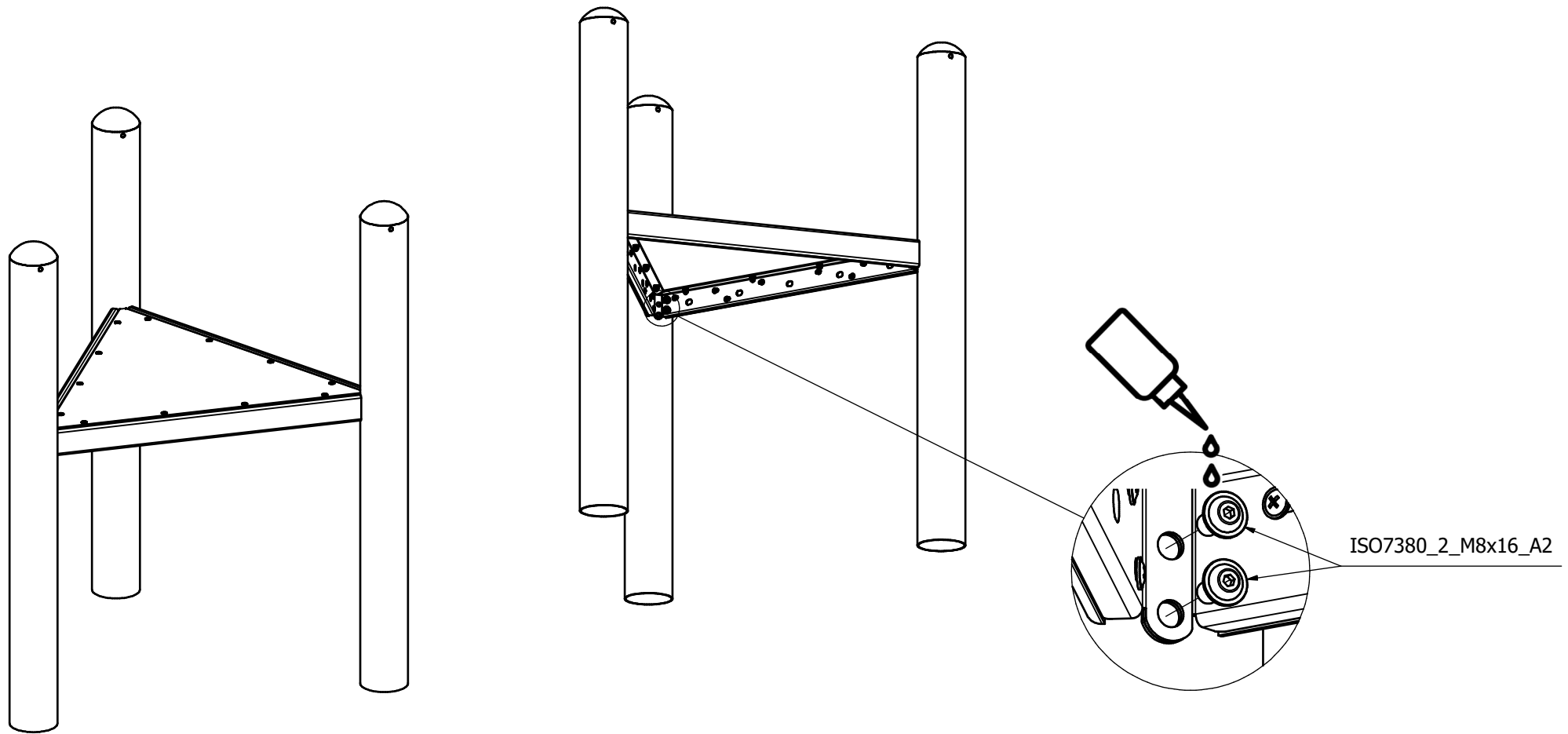

ISO7380_2_M8x16_A2	2
ISO7380_2_M8x40_A2	4
ISO7380_2_M8x35_A2	2
ISO7380_2_M8x30_A2	2
ISO7089_8_A2	4
DIN986_M8_A2	4
8919_001	2
Nr Rys./Normy	Ilość

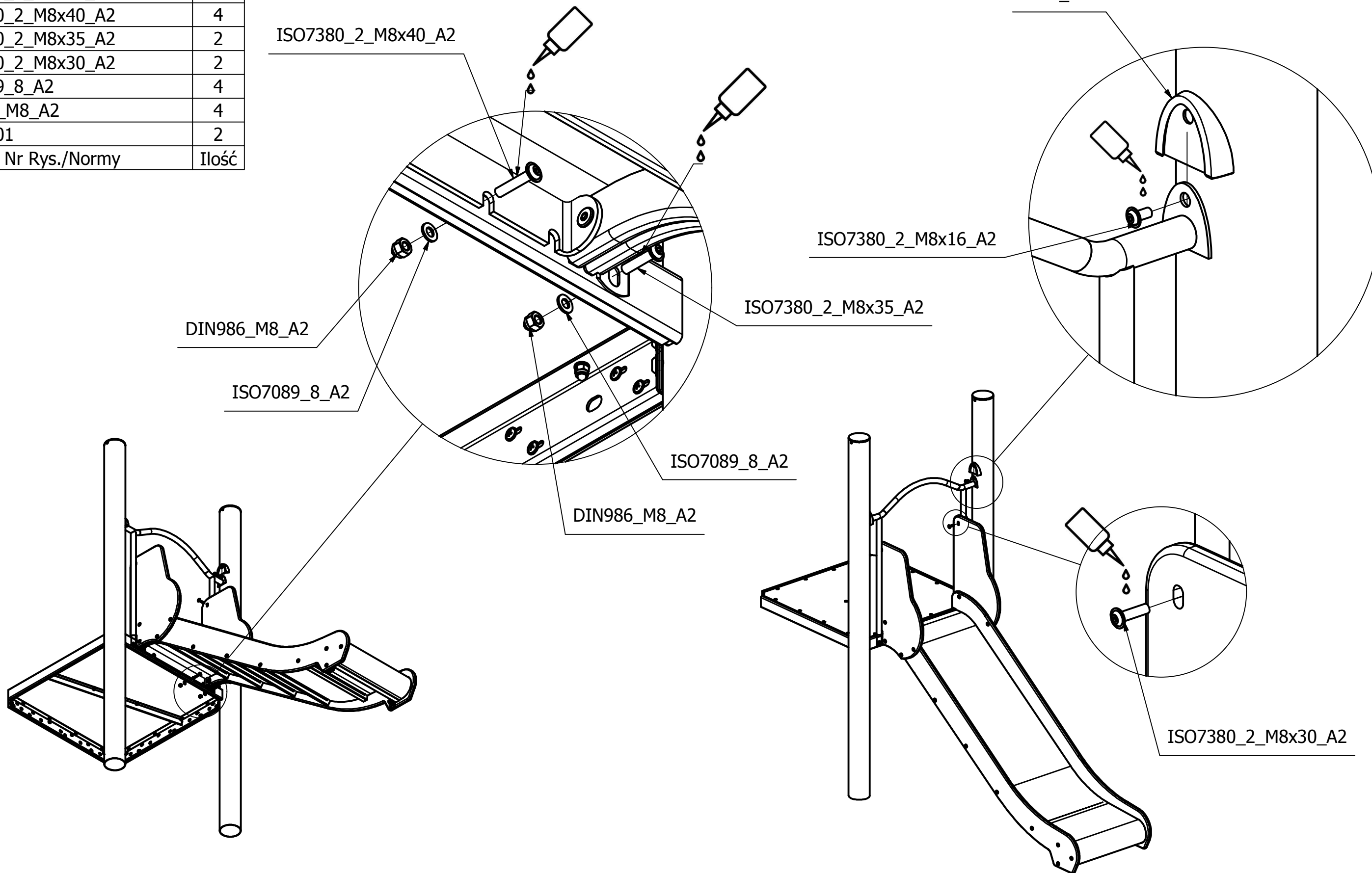

8919_001	2
DIN986_M8_A2	4
ISO7089_8_A2	4
ISO7380_2_M8x16_A2	2
ISO7380_2_M8x30_A2	2
ISO7380_2_M8x35_A2	2
ISO7380_2_M8x40_A2	2
Nr Rys./Normy	Ilość

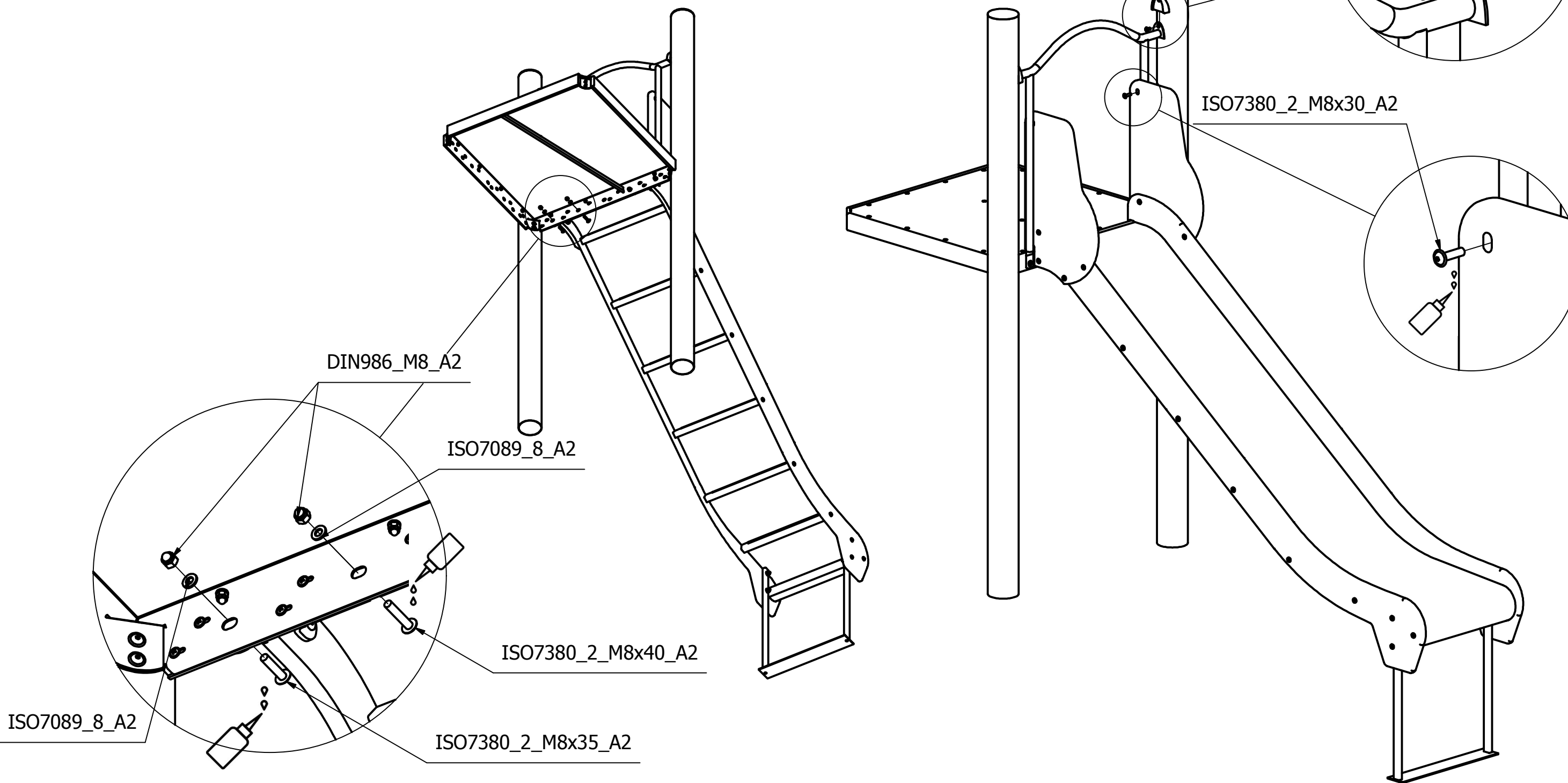

ISO7093_8_A2	16
ISO7380_2_M8x30_A2	16
Nr Rys./Normy	Ilość

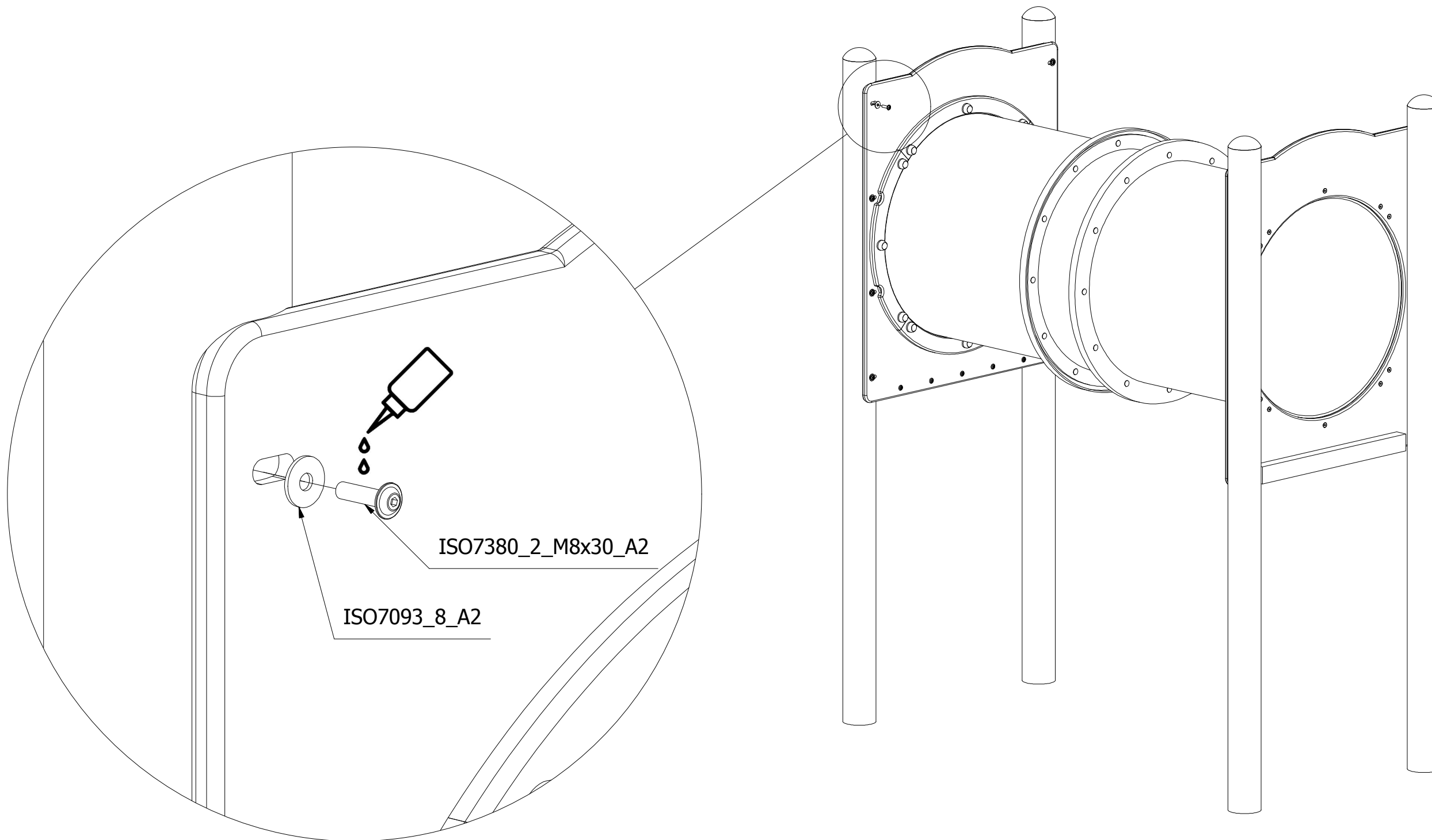

DIN986_M10_A2	4
ISO7089_10_A2	4
ISO7089_8_A2	16
DIN986_M8_A2	16
ISO7380_2_M8x30_A2	24
8919_001	8
Nr Rys./Normy	Ilość

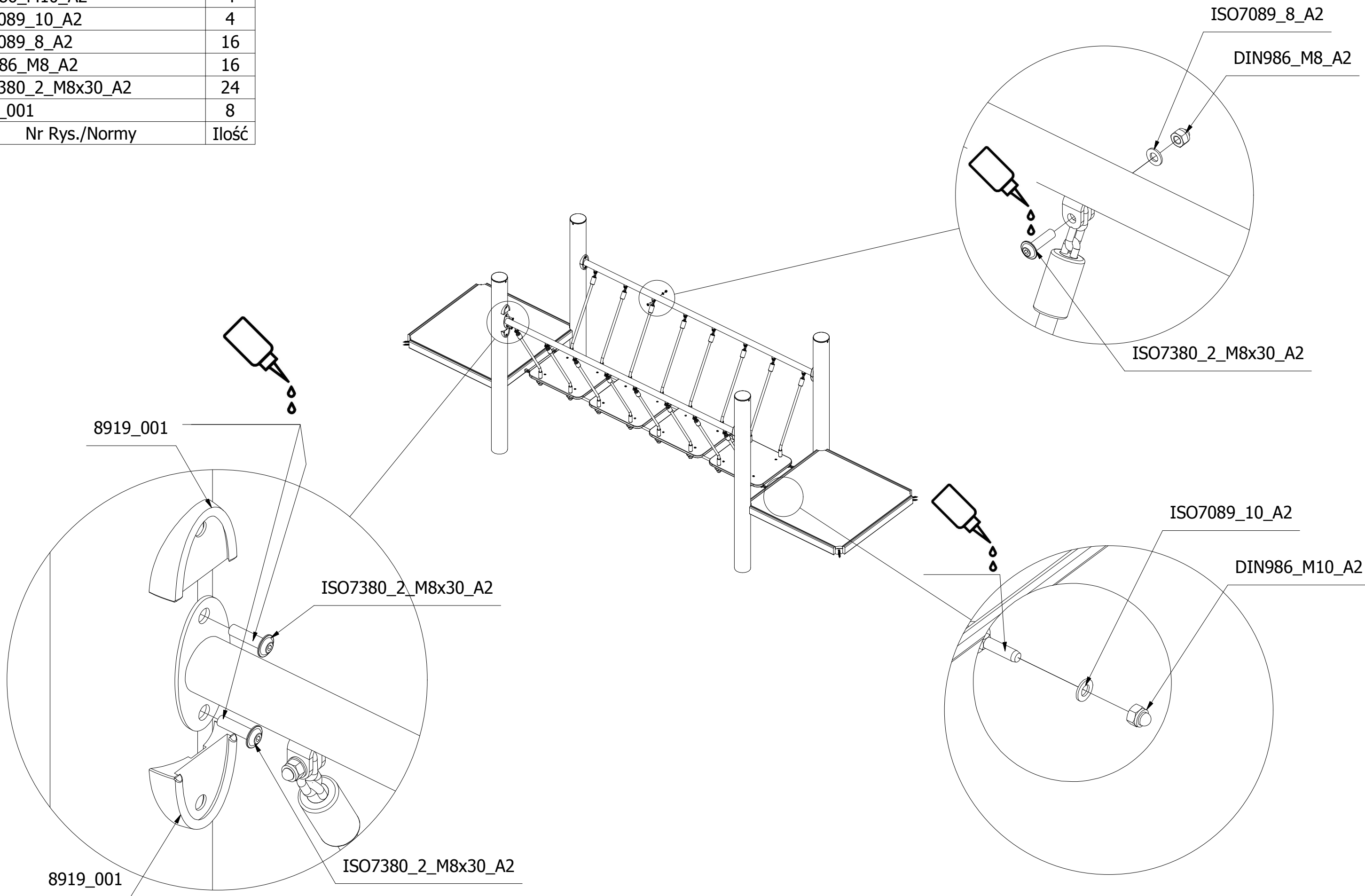

Nr kat. / Cat. no. / Art. Nr.

**22260\_RD**

Nazwa / Product / Name

Pomost linowy z prostokątami - prostokąty na linach

2022-05-06

1 / 1

ISO7380_2_M8x16_A2	4
8919_001	4
Nr Rys./Normy	Ilość

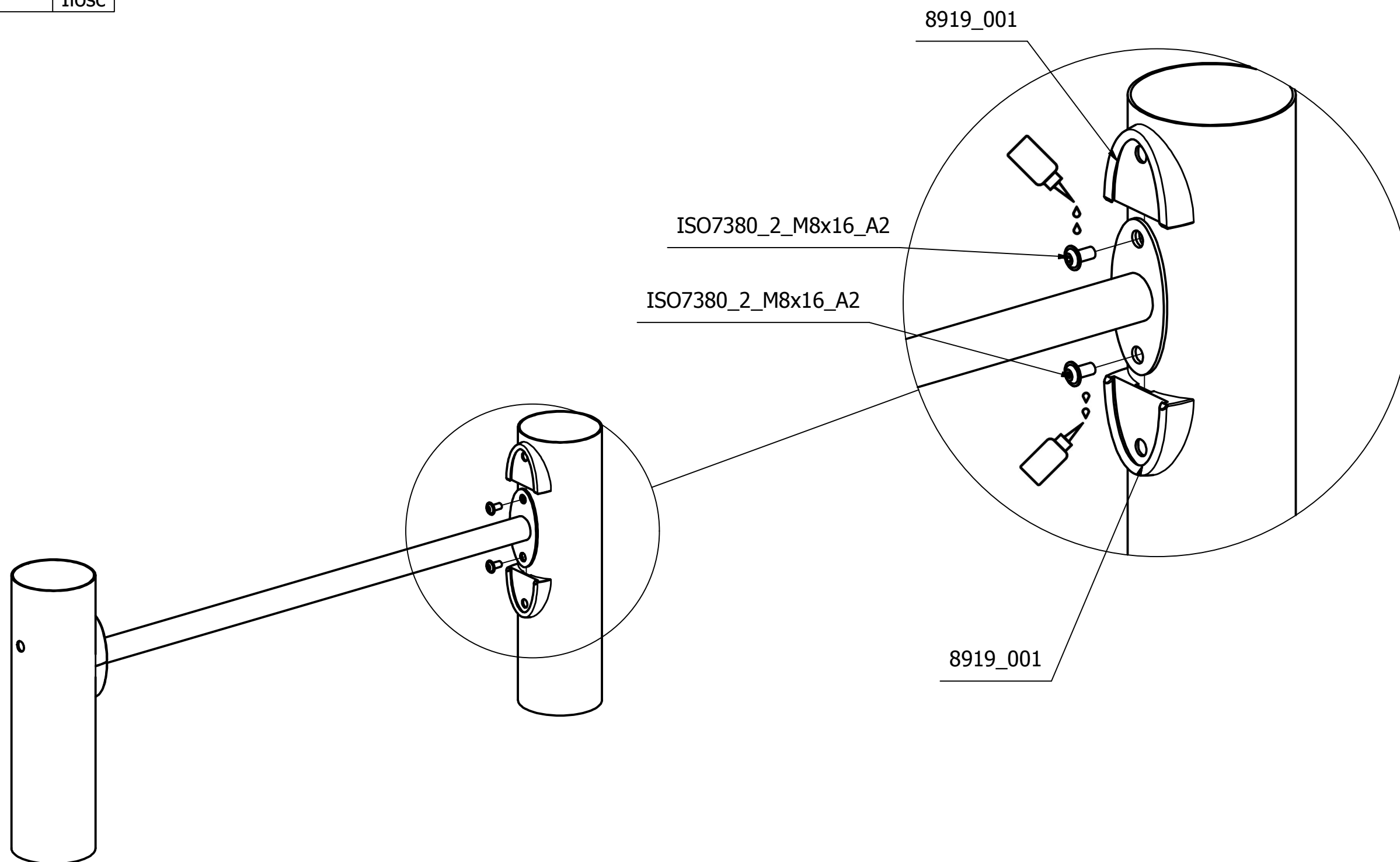

DIN986_M8_A2	2
ISO7089_8_A2	2
ISO7380_2_M8x35_A2	2
ISO7380_2_M8x16_A2	2
8919_001	2
Nr Rys./Normy	Ilość

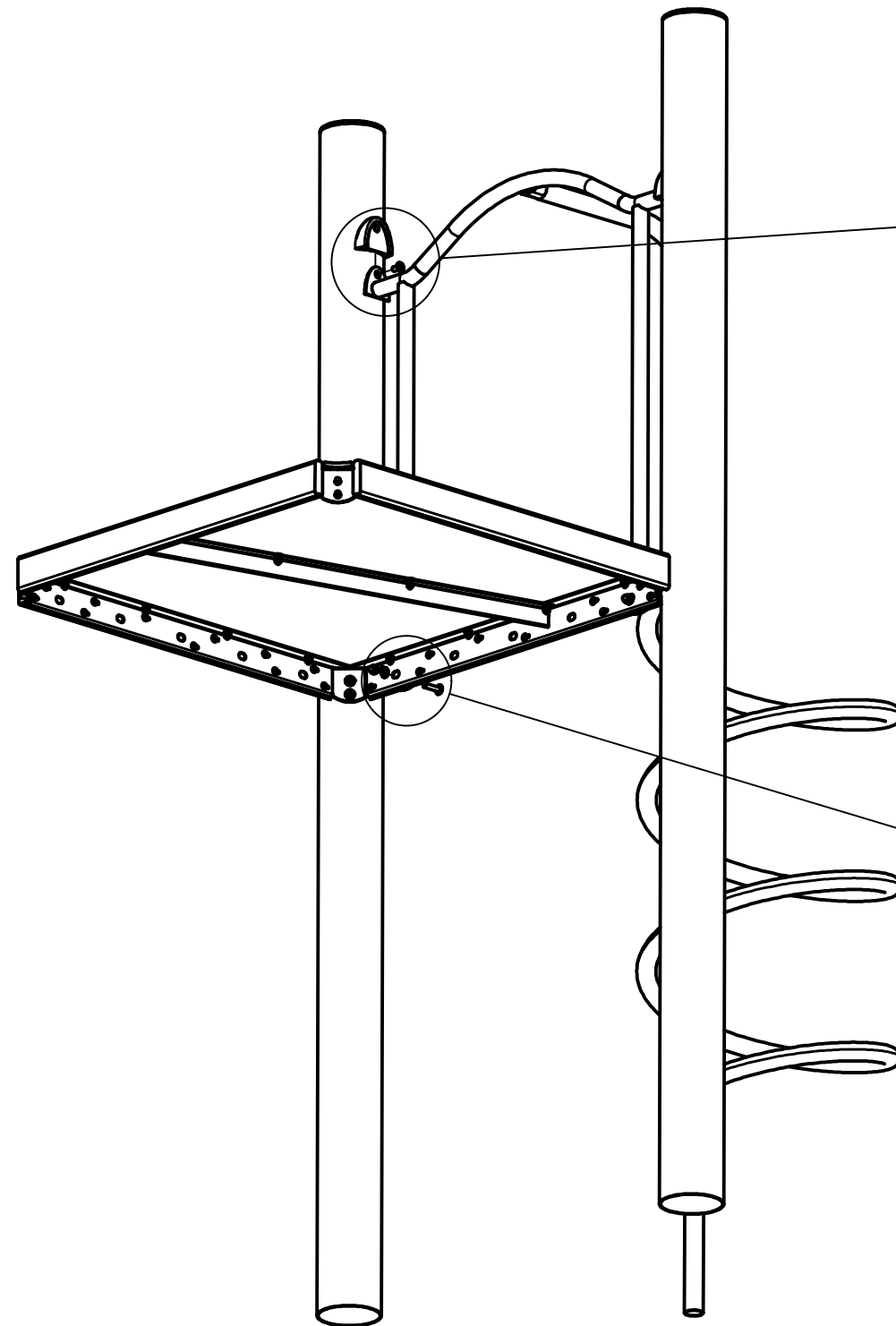

8919\_001

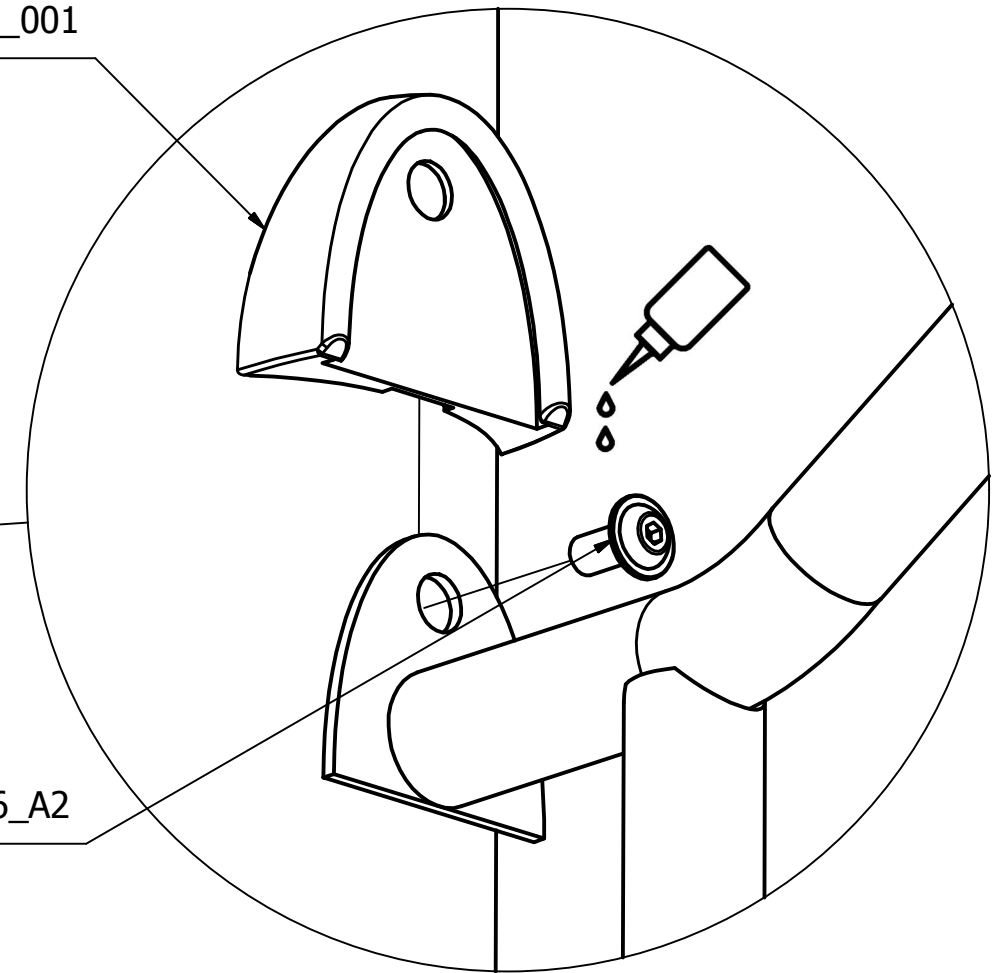

ISO7380\_2\_M8x16\_A2

DIN986\_M8\_A2

ISO7089\_8\_A2

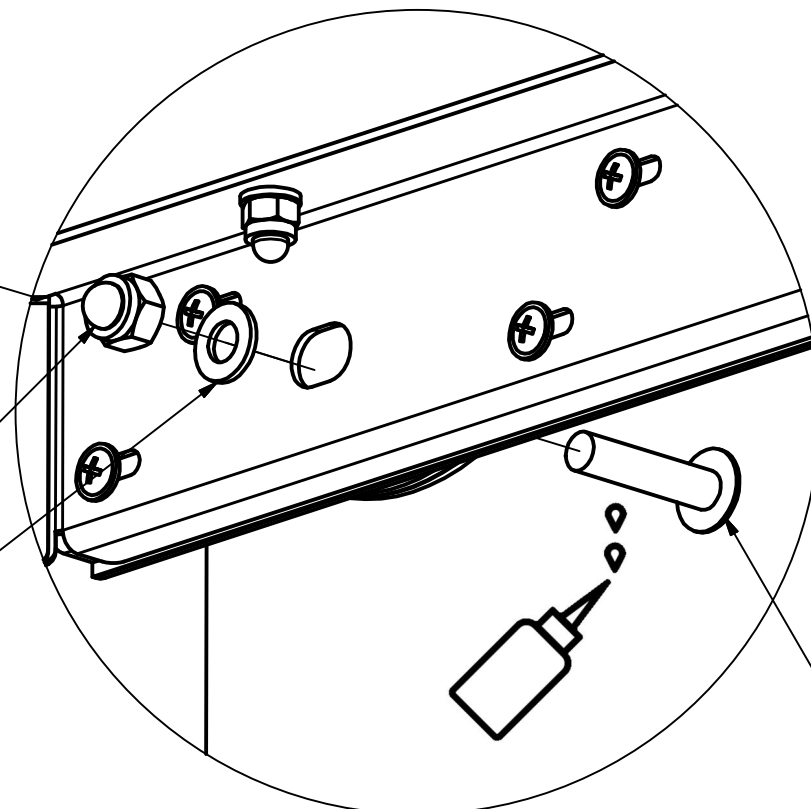

ISO7380\_2\_M8x35\_A2



Nr kat. / Cat. no. / Art. Nr.  
**23103\_RM**

Nazwa / Product / Name  
**Wejście spiralne 120**

2021-06-18  
 1 / 1

DIN986_M8_A2	2
ISO7380_2_M8x35_A2	2
ISO7089_8_A2	2
ISO7380_2_M8x16_A2	2
8919_001	2
Nr Rys./Normy	Ilość

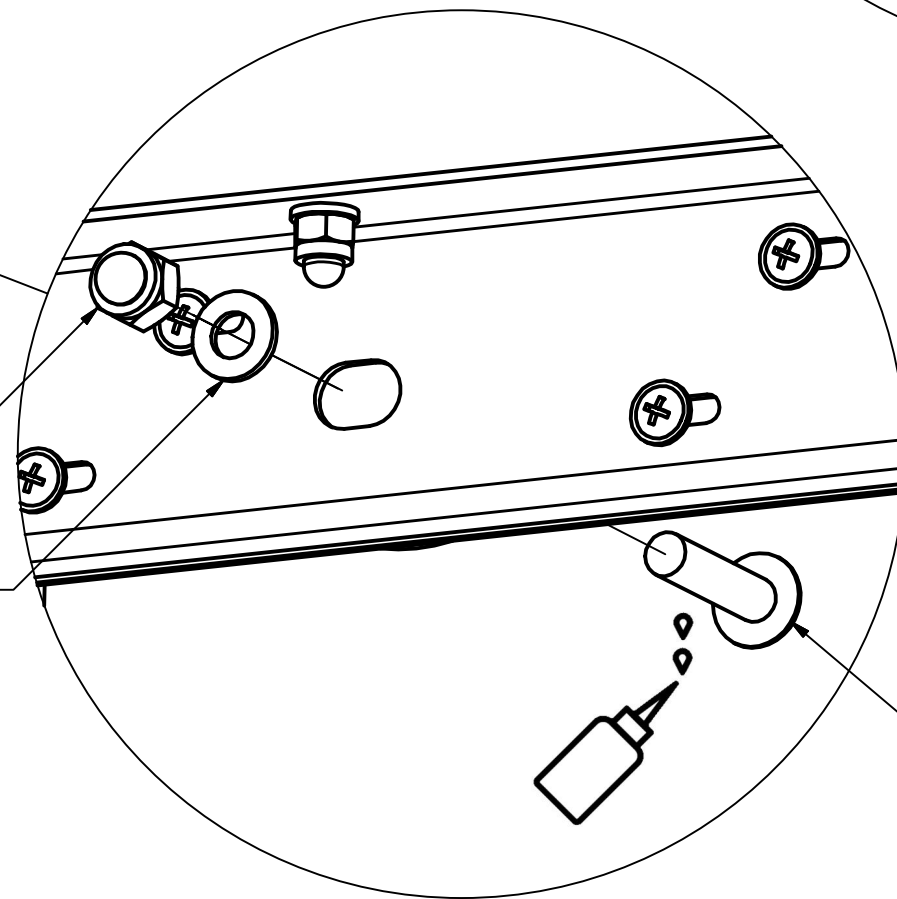
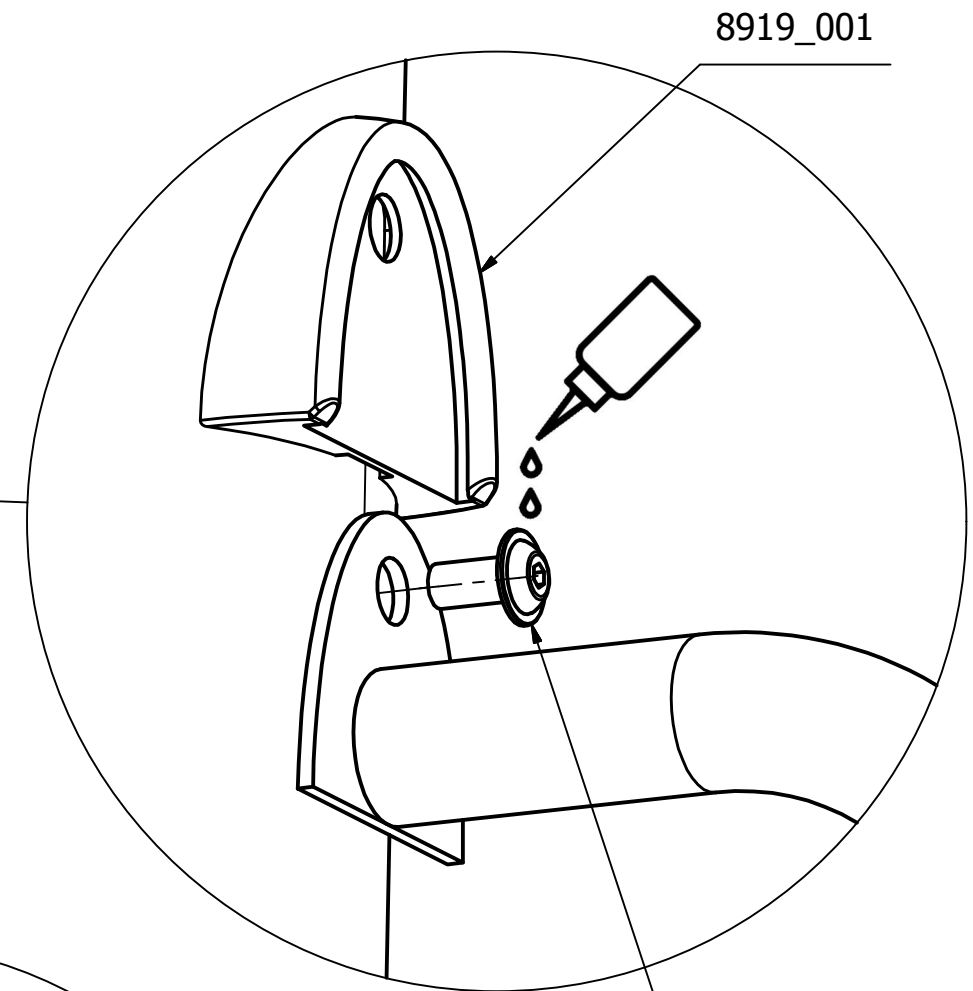
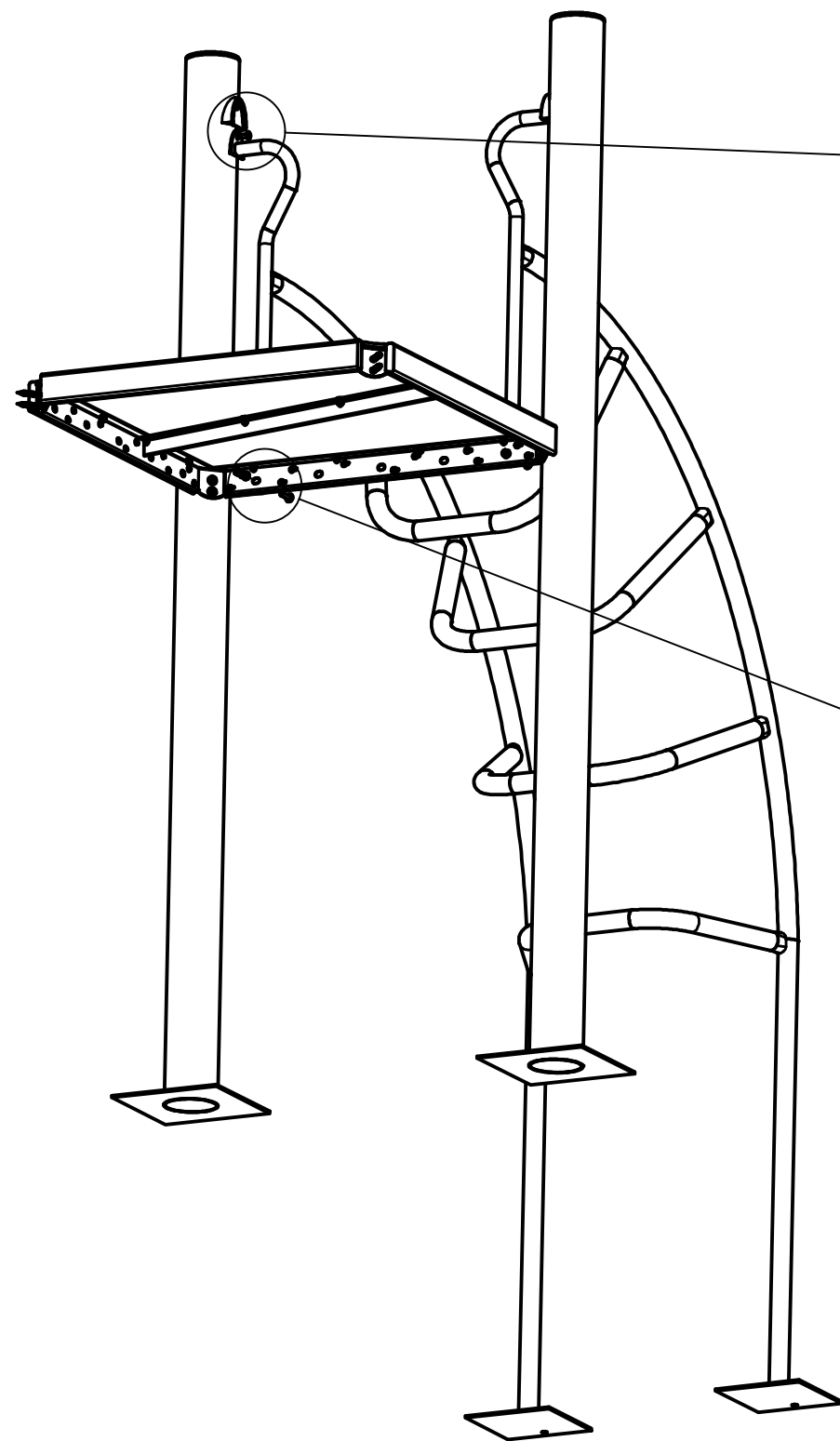

8919\_001

ISO7380\_2\_M8x16\_A2

DIN986\_M8\_A2

ISO7089\_8\_A2

ISO7380\_2\_M8x35\_A2

DIN986_M8_A2	2
ISO7380_2_M8x35_A2	2
ISO7089_8_A2	2
ISO7380_2_M8x16_A2	2
8919_001	2
Nr Rys./Normy	Ilość

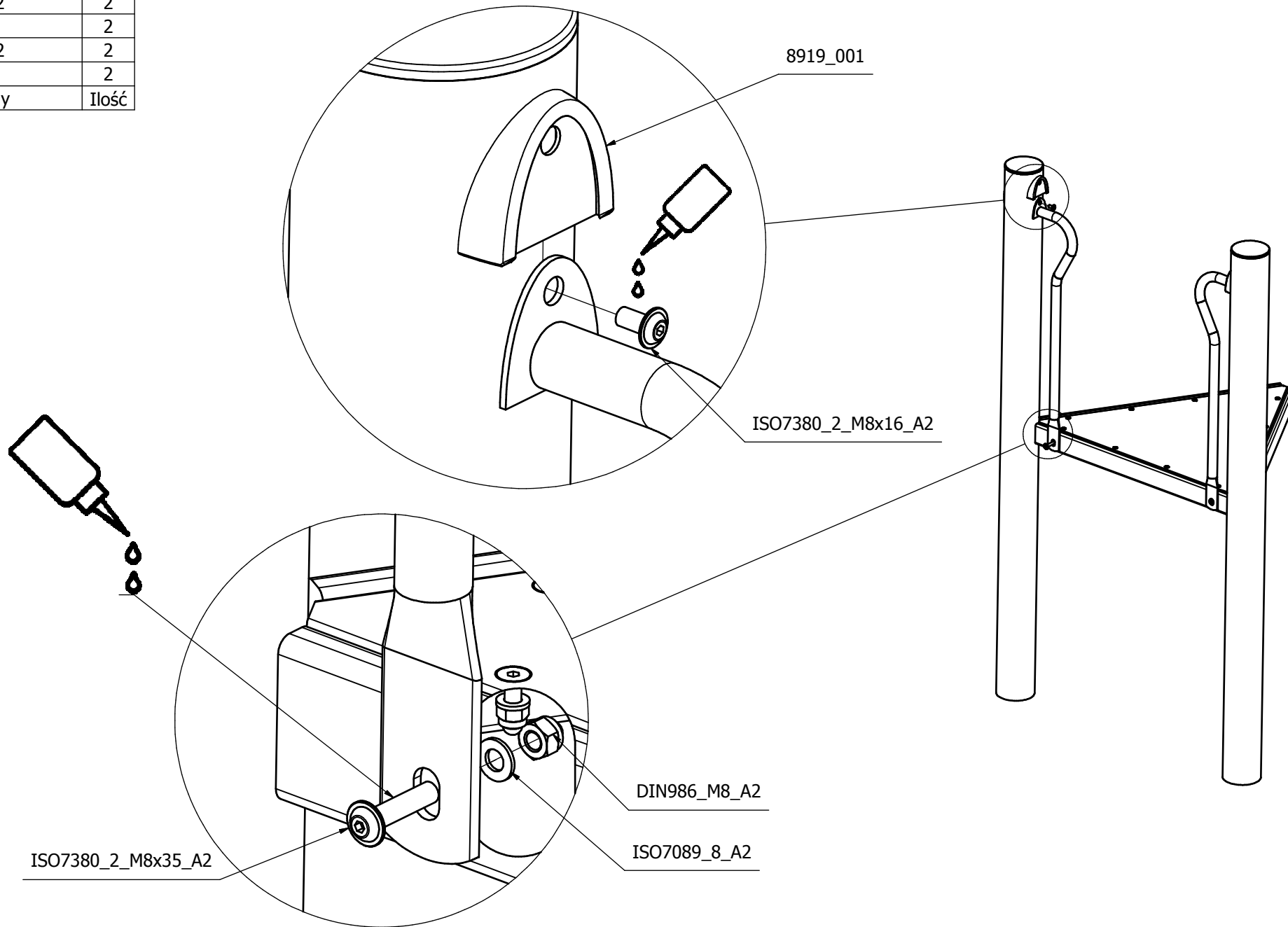

ISO7380_2_M8x16_A2	8
B_8801_041	4
ISO7380_2_M6x10_A2	4
8902_007_A2	4
8919_001	8
Nr Rys./Normy	Ilość

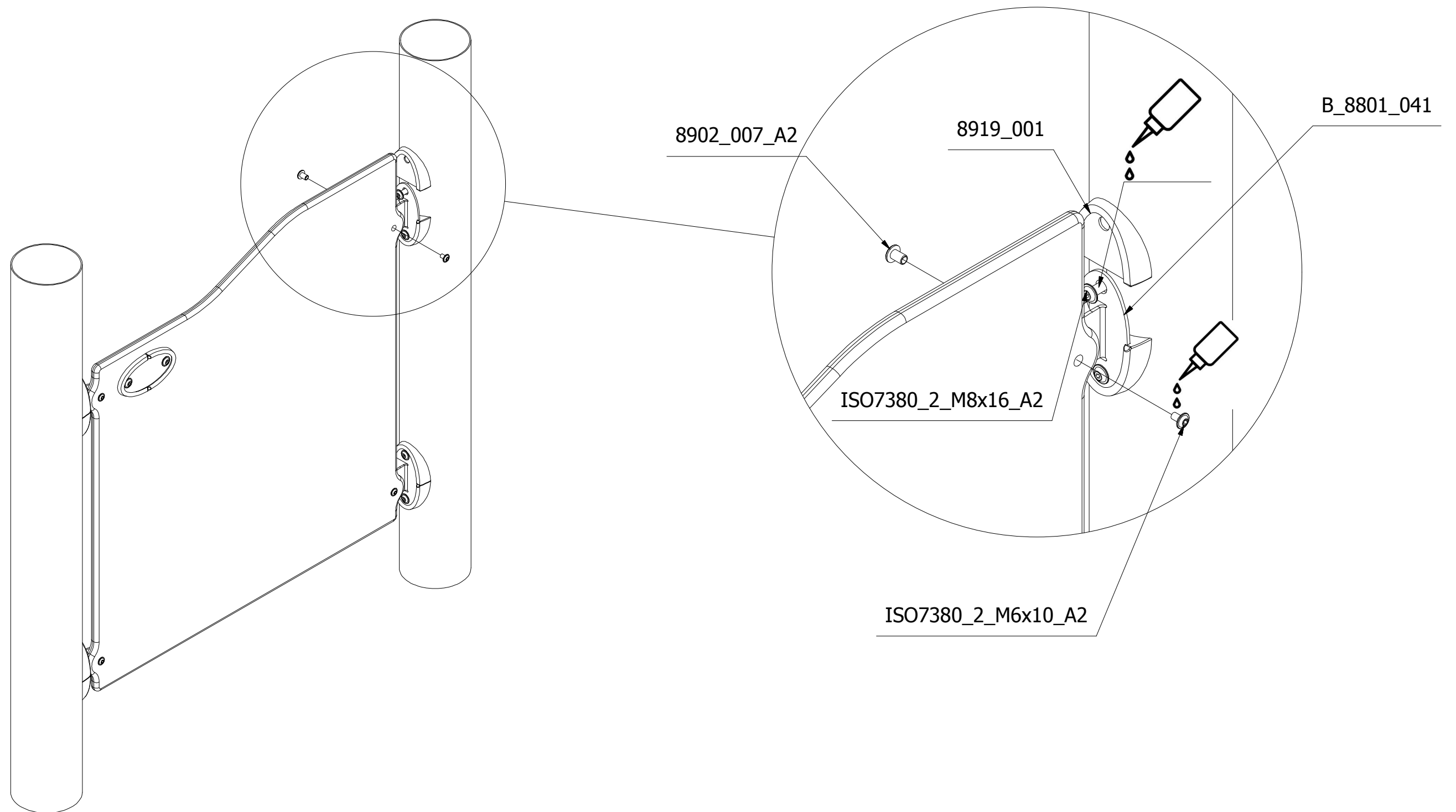

Nr kat. / Cat. no. / Art. Nr.

**2403\_RM**

Nazwa / Product / Name

Zabezpieczenie

2022-03-29

1 / 1