

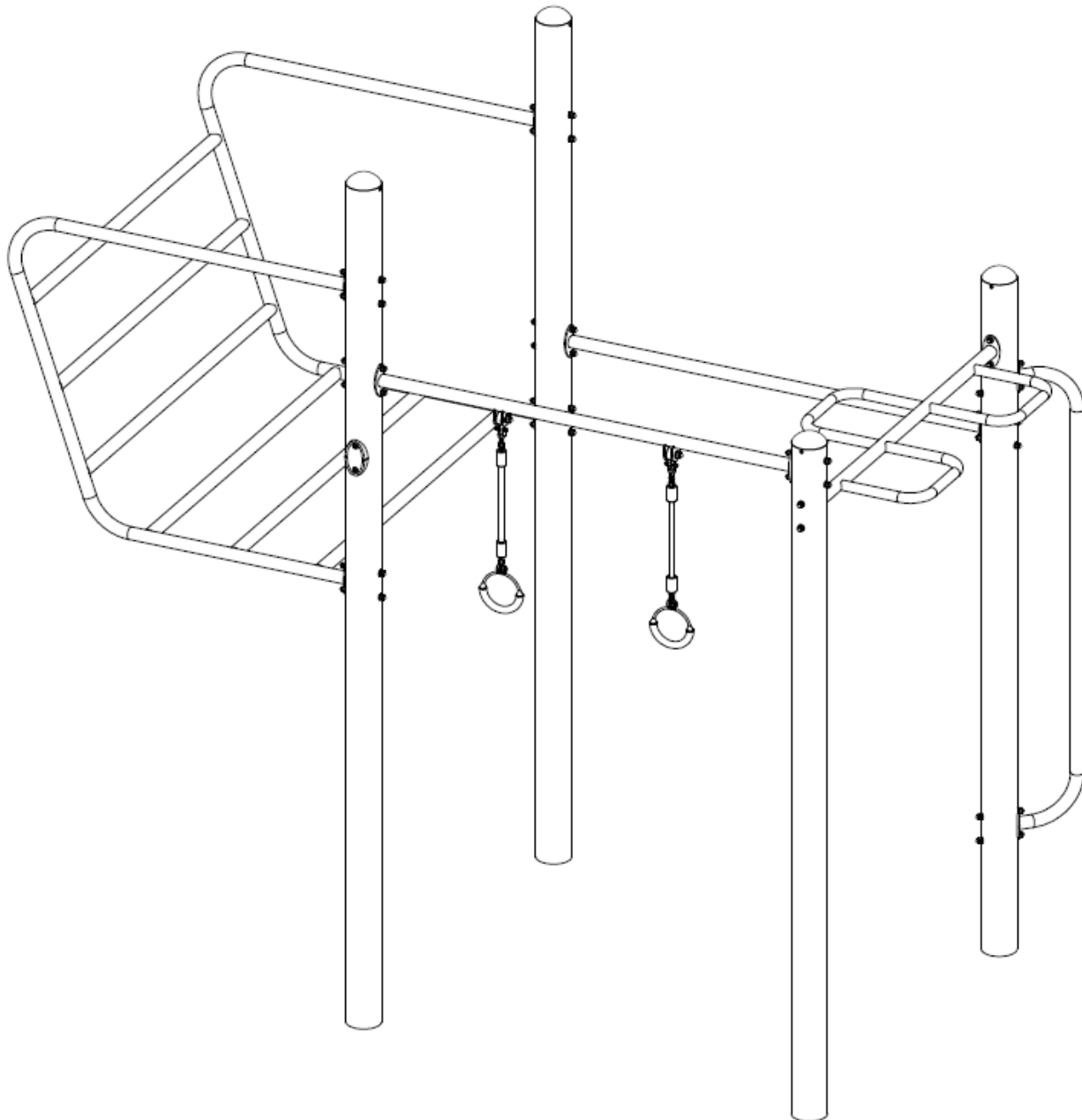

PL	INSTRUKCJA MONTAŻU	Nazwa	Street workout 140	Nr kat.	15140
ENG	ASSEMBLY INSTRUCTIONS	Product	Street workout 140	Cat. no.	
DEU	MONTAGEANLEITUNG	Name	Street workout 140	Art.-Nr.	
FRA	INSTRUCTIONS D'INSTALLATION	Catégorie	Street workout 140	Référence.	

## 15140



Wiek użytkowników Age of users Altersgruppe	Ilość użytkowników Number of users Anzahl der Benutzer Nombre d'utilisateurs	Przeznaczenie urządzenia Purpose of device Bestimmung des Spielgerätes	Zgodność z normą In accordance with the standard Geltende Norm
14 -	5	do zabawy na zewnątrz for outdoor playing zum draußen Spielen	PN-EN 16630:2015
NOVUM Sp. z o.o. Sp. k. ul. Bolesława Chrobrego 1, 12-100 Szczytno		e-mail: <a href="mailto:biuro@novumedukacja.pl">biuro@novumedukacja.pl</a>	<a href="http://www.novumedukacja.pl">www.novumedukacja.pl</a>
NOVUM Sp. z o.o. Sp. k. ul. Bolesława Chrobrego 1, 12-100 Szczytno		e-mail: <a href="mailto:eksport@novumgrom.com">eksport@novumgrom.com</a>	<a href="http://www.novum4kids.com">www.novum4kids.com</a>

**UWAGA / WARNING / ACHTUNG / ATTENTION:**

**PL** Jeżeli w zestawie występuje zjeżdżalnia, zestaw należy posadzić w taki sposób, aby ślizg zjeżdżałni znajdował się od strony północnej, czyli od strony nienasłonecznionej, aby zapobiegać nadmiernemu nagrzewaniu się ślizgu.

**ENG** If there is a slide in the set, it should be installed from the north, poorly sunny side to avoid possible hazards (burns) through direct skin contact.

**DEU** Wenn eine Spielplatzanlage eine Rutsche enthält, sollte diese Anlage so platziert werden, dass die Rutsche sich auf der Nordseite befindet, dh. auf der schattigen Seite, um übermäßige Erwärmung der Rutschbahn zu vermeiden.

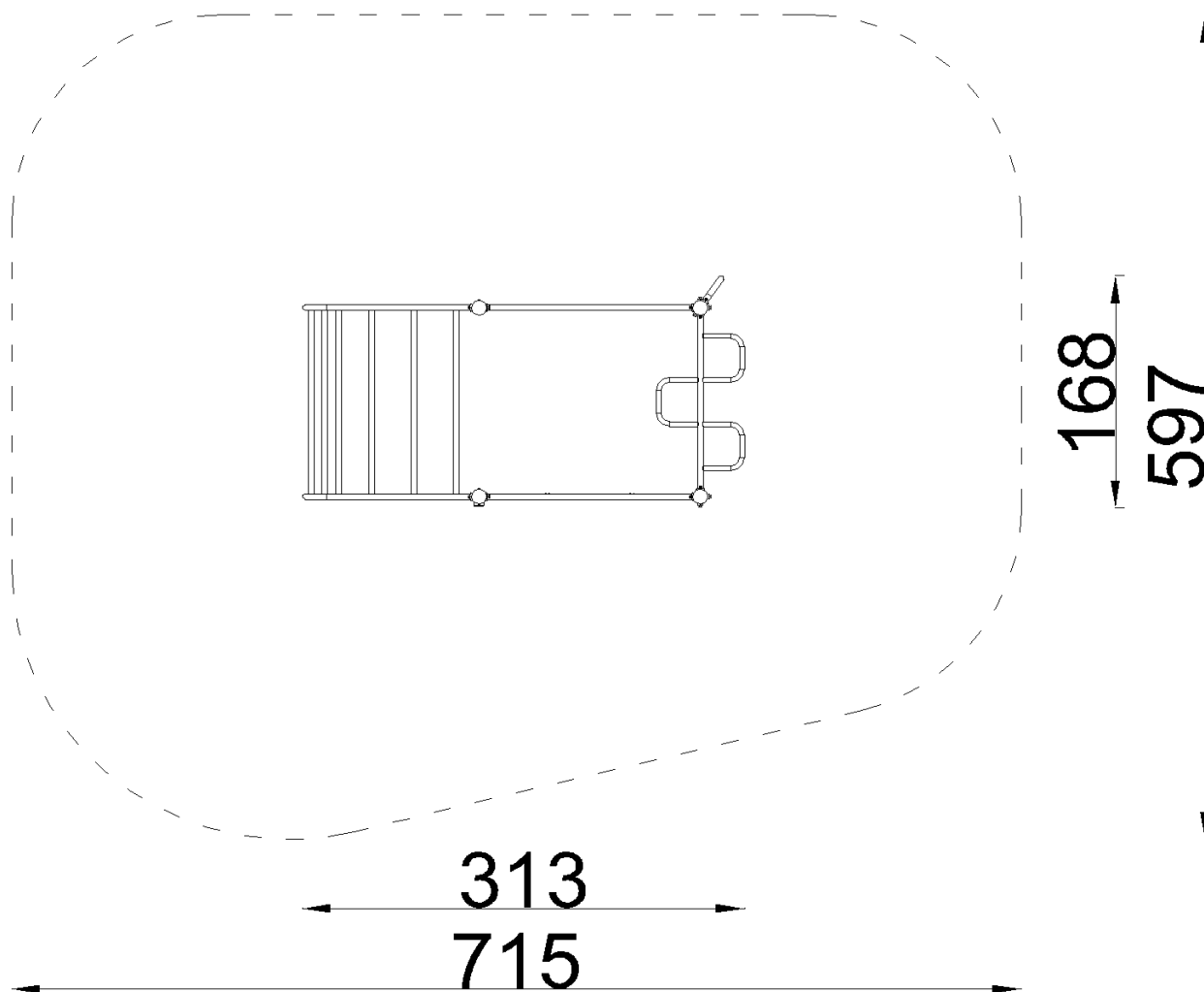

Montaż zgodnie z planem zagospodarowania terenu.  
Installation in accordance with the land development plan.  
Montage gemäß dem Flächennutzungsplan

## Bezpieczna nawierzchnia / Safe surface / Safe Oberfläche / Surface sûre

Strefa Zone Zone Zone	Max. wysokość upadku Max. fall height Max. Fallhöhe Max. hauteur de chute	Pole powierzchni Surface area Fläche Surface	Obwód strefy bezpiecz. Perimeter security zone Umkreis der Fallschutzfläche Zone de périmètre de sé.
A	2,35 m	37,50 m <sup>2</sup>	22,50 m
B	-	-	
C	-	-	

Nawierzchnia / Safe surface / Fallschutzbelag / fr		15140
	Materiał Material Material	Min. wysokość warstwy Min. layer thicknesses Min. Schichtöhe
$h \leq 0,6$ m	Beton / Concrete / Beton Nawierzchnia bitumiczna / Bituminous surfacing / Bituminöse Oberfläche	
$h \leq 1$ m	Gleba / Topsoil / Boden Darń / Turf / Grasnarbe	
$h \leq 2$ m	Kora / Bark / Borke	20÷80 mm
	Wióry / Wood chips / Holzhacksnitzel	5÷30 mm
	Piasek / Sand / Sand Żwir / Gravel / Kies	0,25÷8 mm
$h \leq 3$ m	Kora / Bark / Borke	20÷80 mm
	Wióry / Wood chips / Holzhacksnitzel	5÷30 mm
	Piasek / Sand / Sand Żwir / Gravel / Kies	0,25÷8 mm
$h \leq 3$ m	Nawierzchnia syntetyczna / Synthetic granulates / Synthetische Oberfläche	wg danych producenta acc. to the manufacturer's data nach Angaben des Herstellers

Posadowienie / Foundation / Gründung / Fondation	15140
--	-------

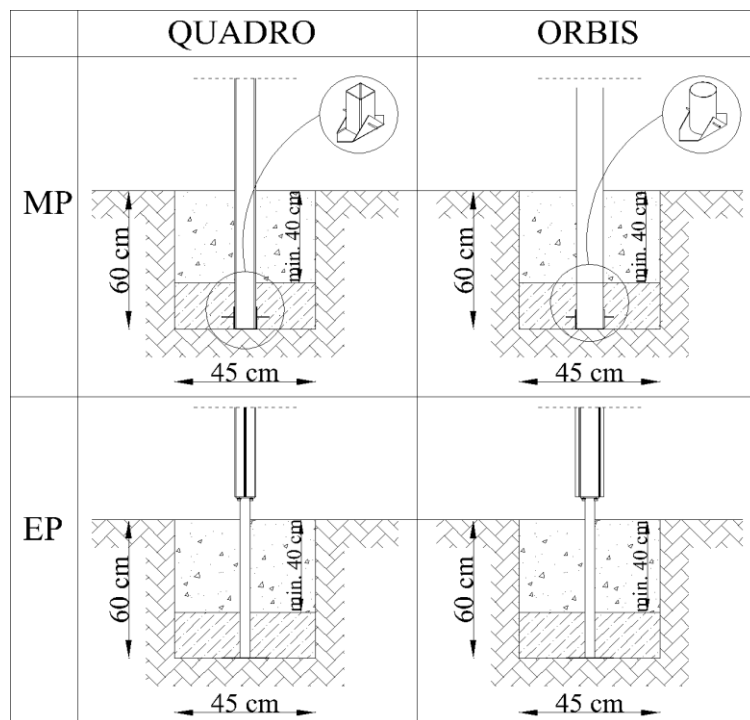

Beton / Concrete / Beton: **C16/20** - **0,16 m<sup>3</sup>**

W celu kontroli fundamentów należy usunąć nawierzchnię bezpieczną / piasek / żwir etc.

In order to control the foundations, remove the safe surface (sand, gravel, etc.)

Um die Fundamente zu überprüfen, entfernen Sie den Fallschutzbelag: Sand/ Kies etc.

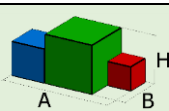
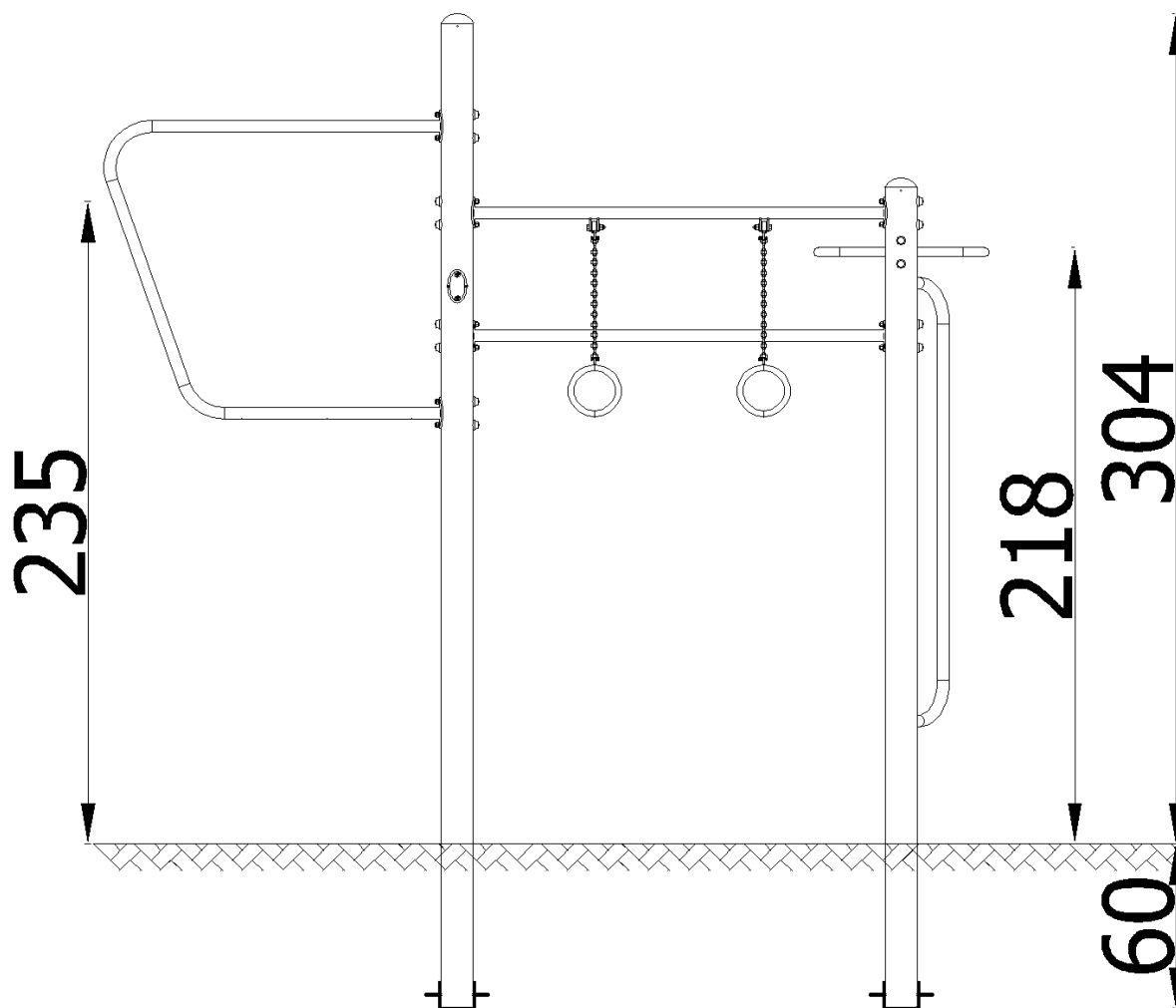

3,13 x 1,68 x  
3,04  
(AxBxH) [m]

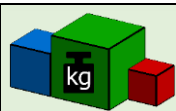

150 kg

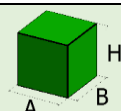

0,12 x 0,12 x  
3,64  
(AxBxH) [m]



41 kg

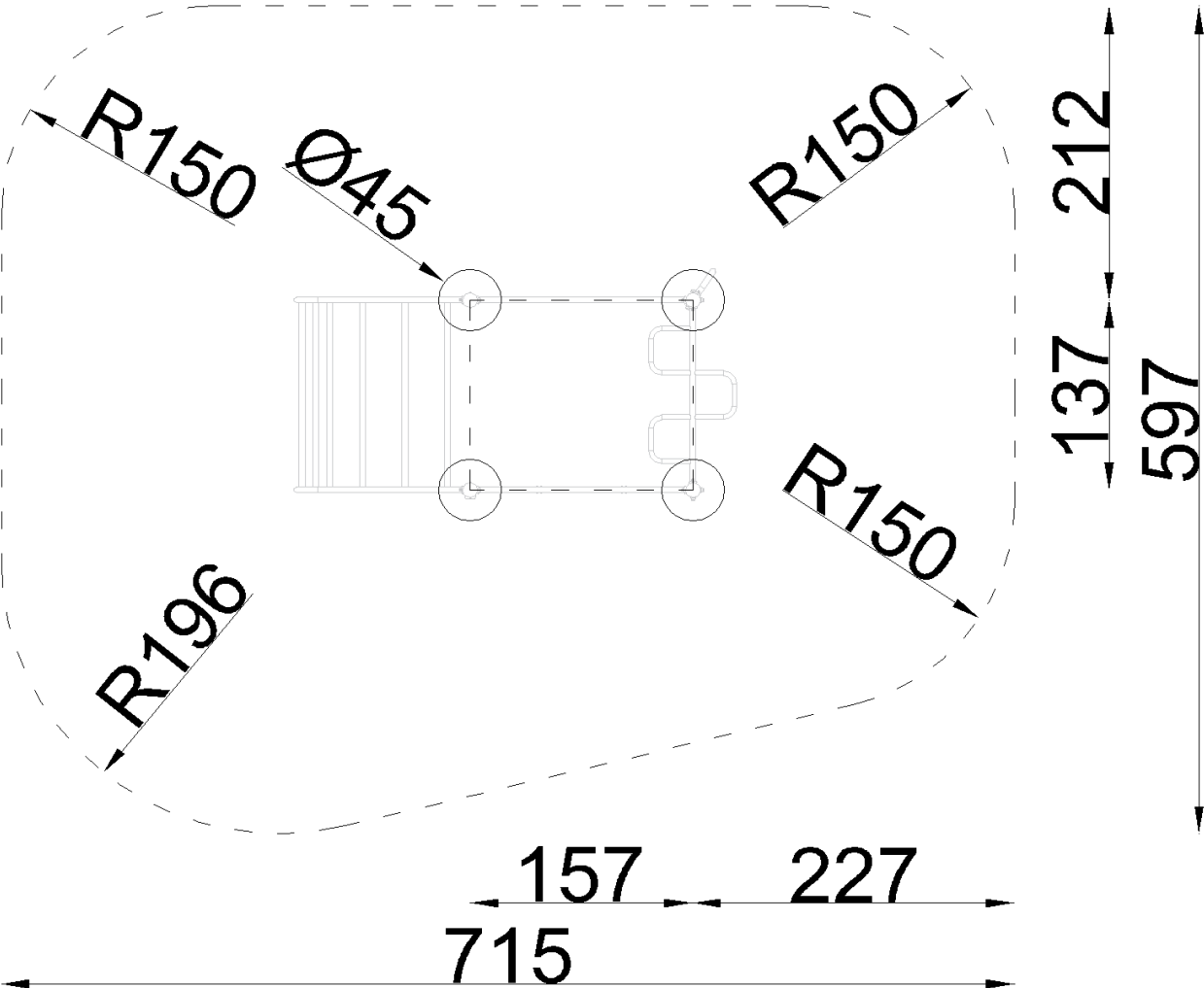

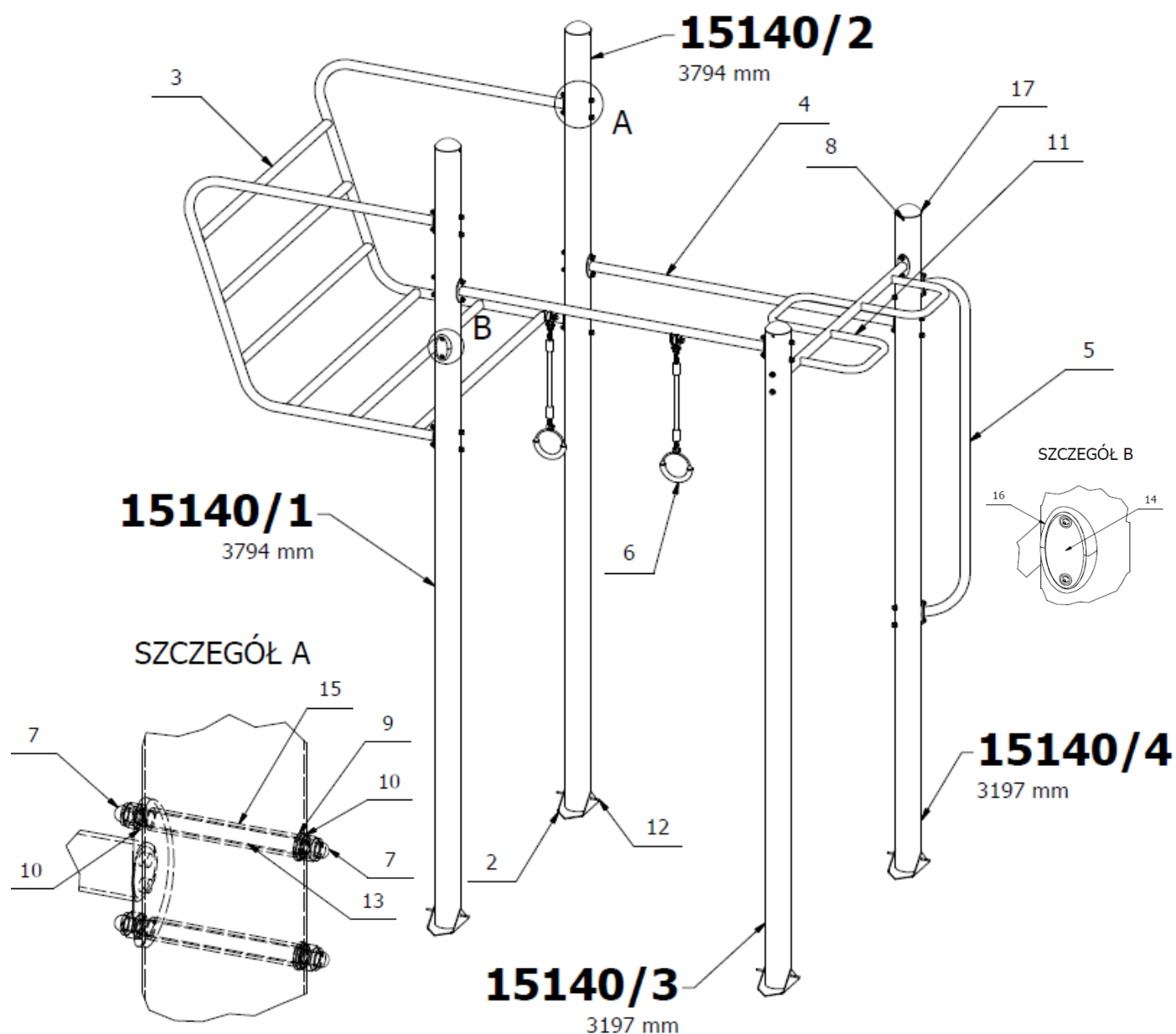



Części zamienne dostępne u producenta. Stosować klej do gwintów w połączeniach śrubowych.  
Spare parts available from the manufacturer. Use thread glue in screw connections.

20	Śruba z łbem podkładkowym	ISO7380_2_M8x16_A2	2				
17	Zaślepka kołpakowa rury114,3	8912_120	4				
16	Wkładka łezka wklęsła	8919_001	2				
15	Tuleja 16x2x112	R_8813_004	24				
14	Tabliczka znamionowa pionowa	8918_002	1				
13	Szpilka gwintowana M10x150	8816_150_A2	24				
12	Pręt 6x200 mm	8850_002	4				
11	Przejście strażackie	L27117_001	1				
10	Podkładka sprężysta	DIN127_10_A2	48				
9	Podkładka	ISO7089_10_A2	24				
8	Nit zrywalny	DIN7337_A5x10	8				
7	Nakrętka kołpakowa	DIN986_M10_A2	48				
6	Kółka gimnastyczne l=1456	27119	1				
5	Drążek pionowy	L2798_001	1				
4	Drążek l=1456	L_27118_001	1				
3	Drabinka pochyła	L27120_001	1				
2	Blacha 3x283x283	B_8802_025	4				
1	Komplet słupów z elementem kotwiącym zestawu 15140	15140/1_15140/4	1				
Lp. Art. Nr.	No. Rep.	Nazwa części Teilename	Part name Nom de la pièce	Nr części Teile-Nr	Part No. Partie No.	Ilość Anzahl	Quantity Nombre

Narzędzia / Tools / Handwerkzeug / Outils

15140

															
								5 m	30 m						
															
2,5 m				60 cm	100 cm										
															
				7 mm								13 mm	17 mm	19 mm	24 mm
															
13 mm	17 mm	19 mm	24 mm	4 mm	5 mm	6 mm	8 mm	T40				T45			
															

8850_002	1
B_8802_025	1
Nr Rys./Normy	Ilość

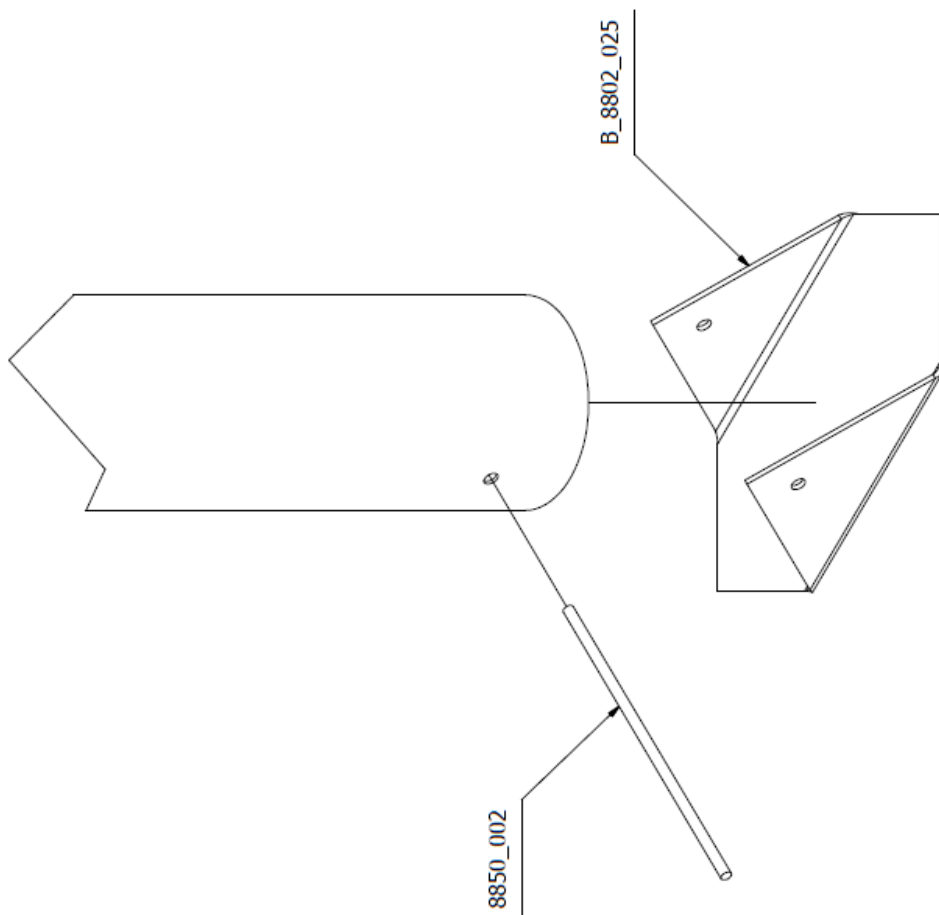



DIN986_M10_A2	4
DIN127_10_A2	4
8816_150_A2	2
R_8813_004	2
ISO7089_10_A2	2
Nr Rys./Normy	Ilość

