



PL	INSTRUKCJA MONTAŻU	Nazwa		Nr kat.	1525
ENG	ASSEMBLY INSTRUCTIONS	Product		Cat. no.	
DEU	MONTAGEANLEITUNG	Name		Art.-Nr.	
FRA	INSTRUCTIONS D'INSTALLATION	Catégorie		Référence.	

1525



Wiek użytkowników Age of users Altersgruppe	Ilość użytkowników Number of users Anzahl der Benutzer Nombre d'utilisateurs	Przeznaczenie urządzenia Purpose of device Bestimmung des Spielgerätes	Zgodność z normą In accordance with the standard Geltende Norm
14 -	3	do zabawy na zewnątrz for outdoor playing zum draußen Spielen	PN-EN 16899:2017
NOVUM Sp. z o.o. Sp. k. ul. Bolesława Chrobrego 1, 12-100 Szczytno		e-mail: biuro@novumedukacja.pl	www.novumedukacja.pl
NOVUM Sp. z o.o. Sp. k. ul. Bolesława Chrobrego 1, 12-100 Szczytno		e-mail: eksport@novumgrom.com	www.novum4kids.com
NOVUM Deutschland GmbH, Schiffgesweg 11, 50259 Pulheim		e-mail: service@novum4kids.de	www.novum4kids.de
NOVUM DIRECT France Centre Commerciale La Samiane 01290 CROTTET		e-mail: contact@novum-direct.fr	www.novum-direct.fr

UWAGA / WARNING / ACHTUNG / ATTENTION:

PL Jeżeli w zestawie występuje zjeżdżalnia, zestaw należy posadzić w taki sposób, aby ślizg zjeżdżalni znajdował się od strony północnej, czyli od strony nienasłonecznionej, aby zapobiegać nadmiernemu nagrzewaniu się ślizgu.

ENG If there is a slide in the set, it should be installed from the north, poorly sunny side to avoid possible hazards (burns) through direct skin contact.

DEU Wenn eine Spielplatzanlage eine Rutsche enthält, sollte diese Anlage so platziert werden, dass die Rutsche sich auf der Nordseite befindet, dh. auf der schattigen Seite, um übermäßige Erwärmung der Rutschbahn zu vermeiden.

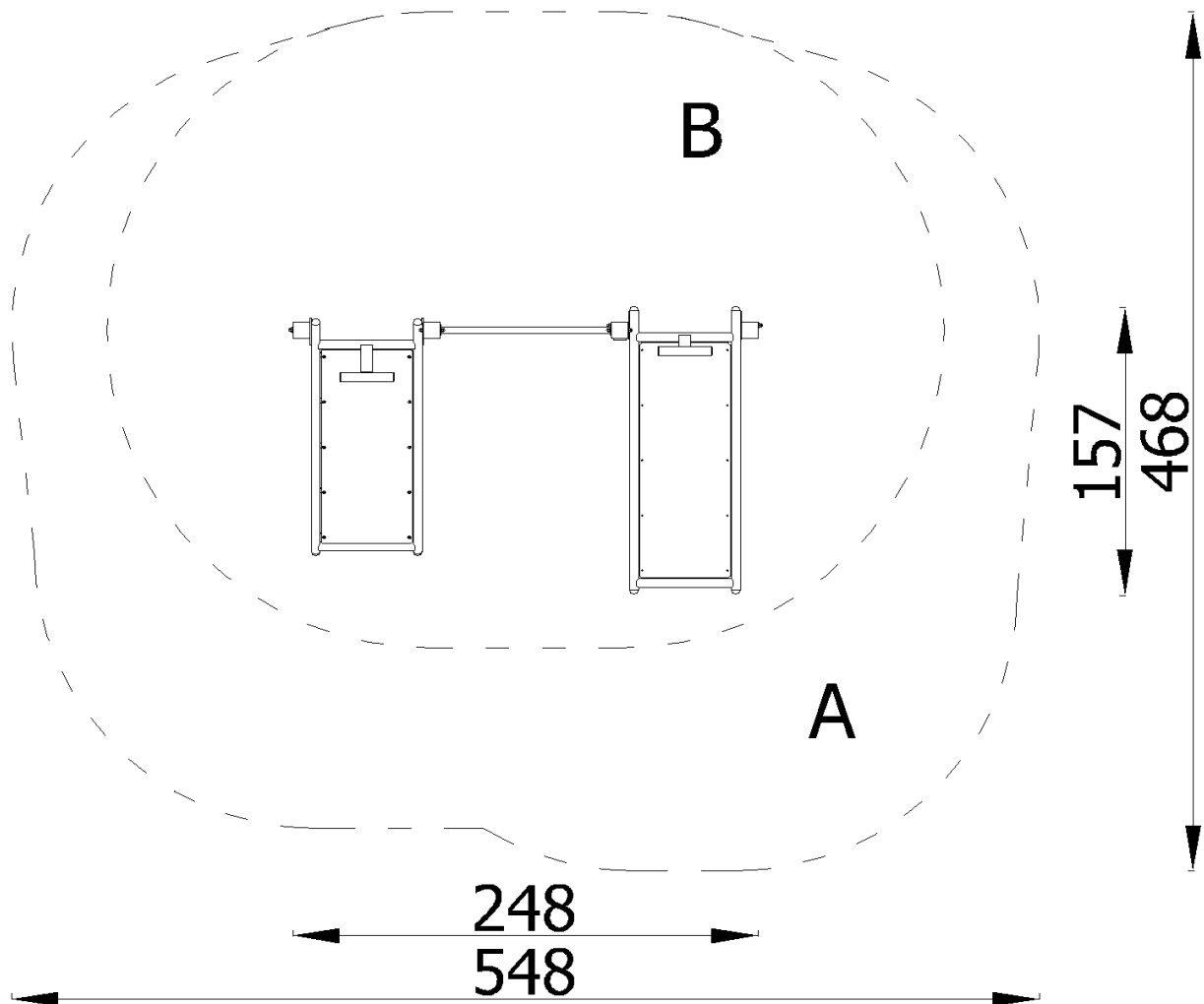

Montaż zgodnie z planem zagospodarowania terenu.
 Installation in accordance with the land development plan.
 Montage gemäß dem Flächennutzungsplan

Bezpieczna nawierzchnia / Safe surface / Safe Oberfläche / Surface sûre

Strefa Zone Zone Zone	Max. wysokość upadku Max. fall height Max. Fallhöhe Max. hauteur de chute	Pole powierzchni Surface area Fläche Surface	Obwód strefy bezpiecz. Perimeter security zone Umkreis der Fallschutzfläche Zone de périmètre de sé.
A	1,00 m	9,00 m ²	17,00 m
B	1,82 m	13,00 m ²	
C	-	-	

Nawierzchnia / Safe surface / Fallschutzbelag / fr			1525
	Materiał Material Material	Min. wysokość warstwy Min. layer thicknesses Min. Schichtöhe	
h<0,6 m	Beton / Concrete / Beton Nawierzchnia bitumiczna / Bituminous surfacing / Bituminöse Oberfläche		
h<1 m	Gleba / Topsoil / Boden Darıń / Turf / Grasnarbe		
h<2 m	Kora / Bark / Borke	20÷80 mm	300
	Wióry / Wood chips / Holzhacksnitzel	5÷30 mm	
	Piasek / Sand / Sand Żwir / Gravel / Kies	0,25÷8 mm	
h<3 m	Kora / Bark / Borke	20÷80 mm	400
	Wióry / Wood chips / Holzhacksnitzel	5÷30 mm	
	Piasek / Sand / Sand Żwir / Gravel / Kies	0,25÷8 mm	
h<3 m	Nawierzchnia syntetyczna / Synthetic granulates / Synthetische Oberfläche	wg danych producenta acc. to the manufacturer's data nach Angaben des Herstellers	

Posadowienie / Foundation / Gründung / Fondation	1525
--	------

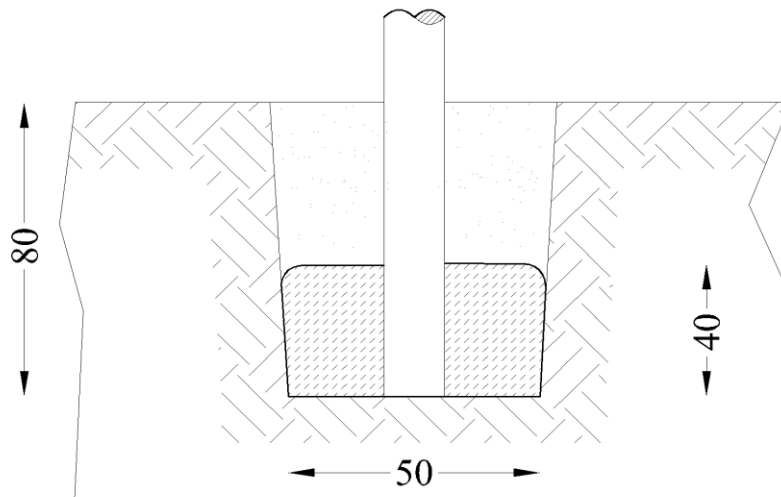

Beton / Concrete / Beton: **C16/20** - **0,80 m³**

W celu kontroli fundamentów należy usunąć nawierzchnię bezpieczną / piasek / żwir etc.

In order to control the foundations, remove the safe surface (sand, gravel, etc.)

Um die Fundamente zu überprüfen, entfernen Sie den Fallschutzbelag: Sand/ Kies etc.

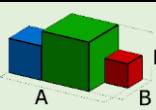
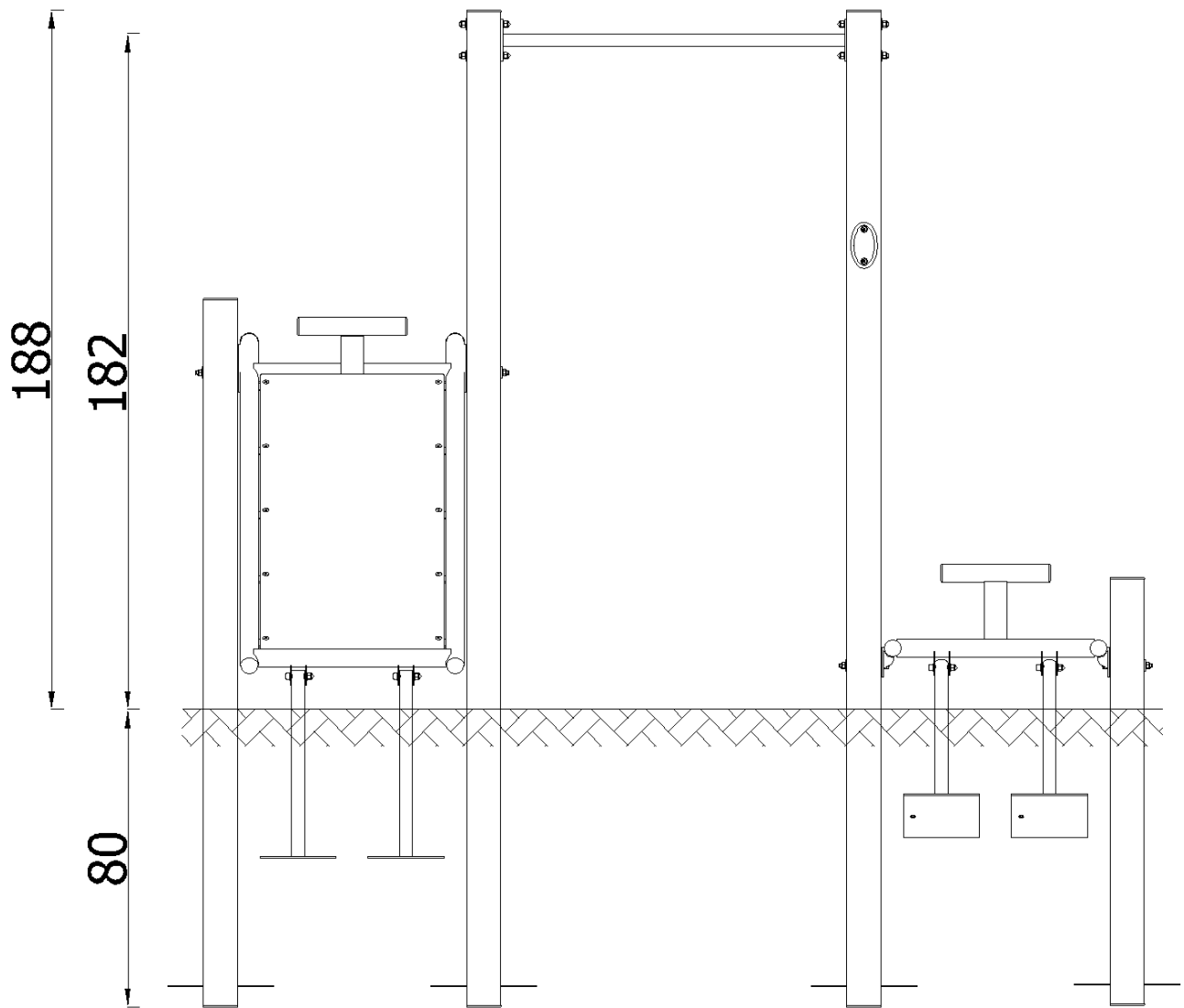

2,48x1,57x1,88
(AxBxH) [m]

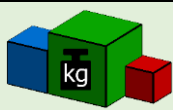

134 kg

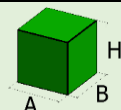

0,09x0,09x2,67
(AxBxH) [m]



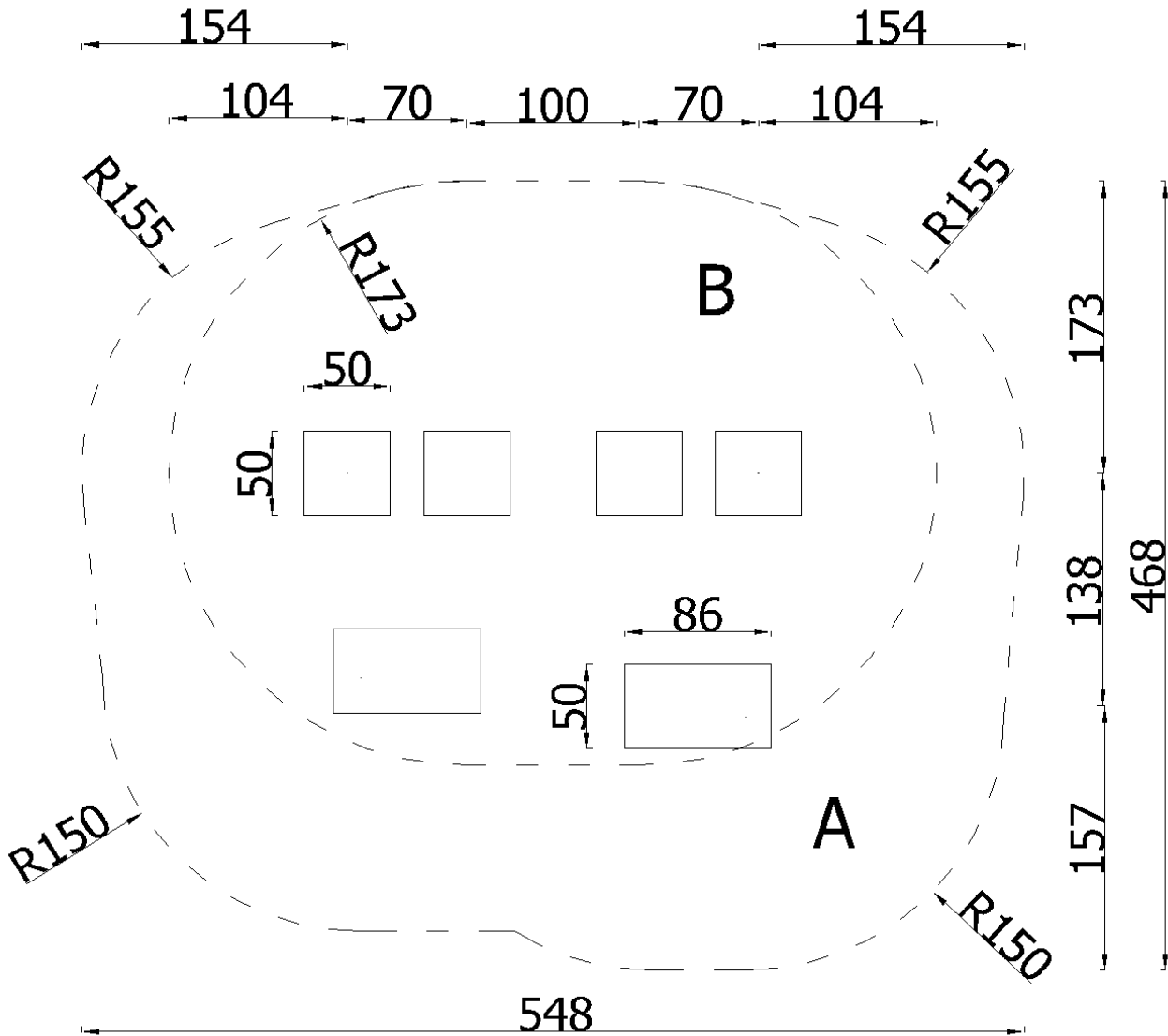

29 kg

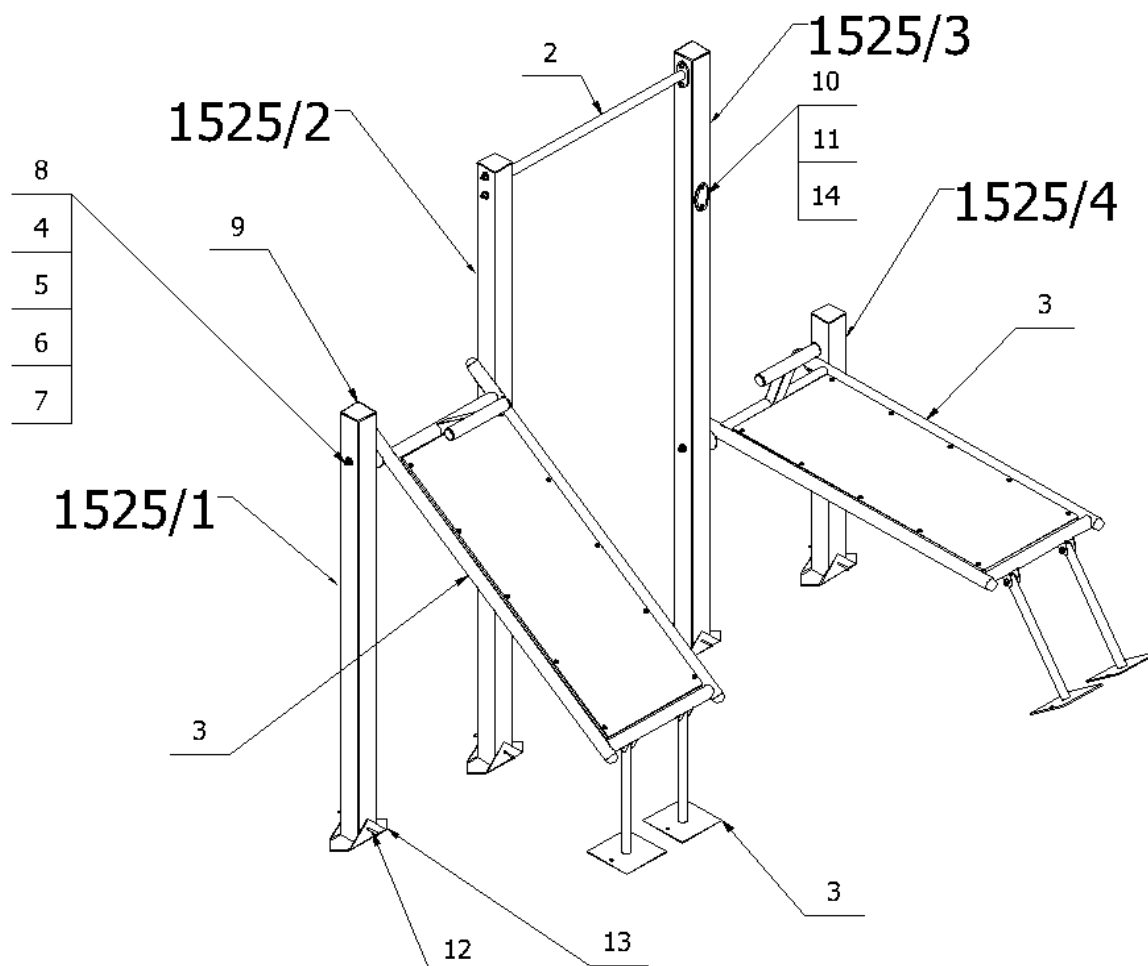



14	Śruba z łbem podkładowym	ISO7380_2_M8x16_A2	2	A2	0,010	
13	Blacha 3x200x200	B_8802_027	4	S235JR	0,943	
12	Pręt 6x200 mm	8850_002	4	Stal	0,044	
11	Wkładka łezka płaska	8919_002	2	PE	0,011	600732
10	Tabliczka znamionowa pionowa	8918_002	1	Al	0,007	0899012
9	Zaślepka kwadratowa 90x90	8912_212	4	PE	0,049	
8	Szpilka gwintowana M10x130	8816_130_A2	8	A2	0,010	
7	Podkładka szeroka	ISO7093_10_A2	8	A2	0,012	
6	Podkładka sprężysta	DIN127_10_A2	16	A2	0,003	
5	Tuleja 16x2x89mm	R_8813_003	8	Stal oc.	0,008	
4	Nakrętka kołpakowa	DIN986_M10_A2	16	A2	0,018	
3	Ławka do brzuszków	1524	2		28,801	
2	Drażek 90	2701_QM	1		3,086	
1	Komplet słupów z elementem kotwiącym zestawu 1525	1525/1_1525/4	1			
Nr.	Nazwa	Nr Rys./Normy	Il.	Materiał	Masa	Uwagi

Części zamienne dostępne u producenta. Stosować klej do gwintów w połączeniach śrubowych.
 Spare parts available from the manufacturer. Use thread glue in screw connections.
 Ersatzteile beim Hersteller erhältlich. Gewindekleber für Schraubverbindungen verwenden.

															
								5 m	30 m						
															
2,5 m				60 cm	100 cm										
															
				7 mm								13 mm	17 mm	19 mm	24 mm
															
13 mm	17 mm	19 mm	24 mm	4 mm	5 mm	6 mm	8 mm	T40				T45			
															

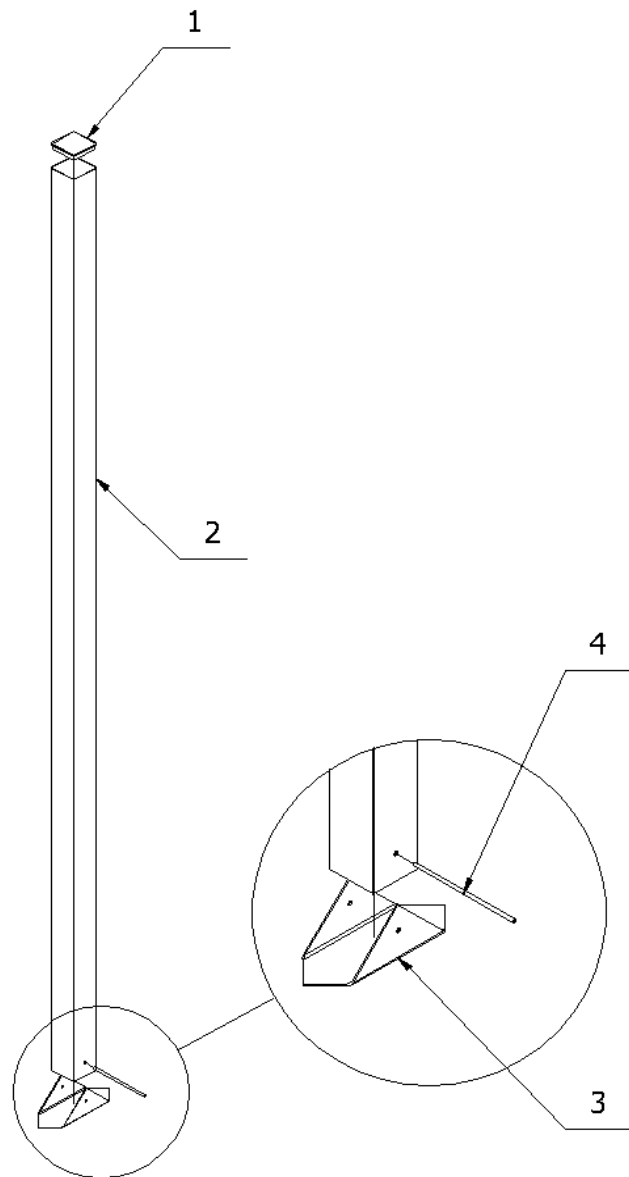

4	1	8850_002
3	1	B_8802_027
2	1	SŁUP / POLE
1	1	8912_212
Nr.	Il.	Nr Rys./Normy

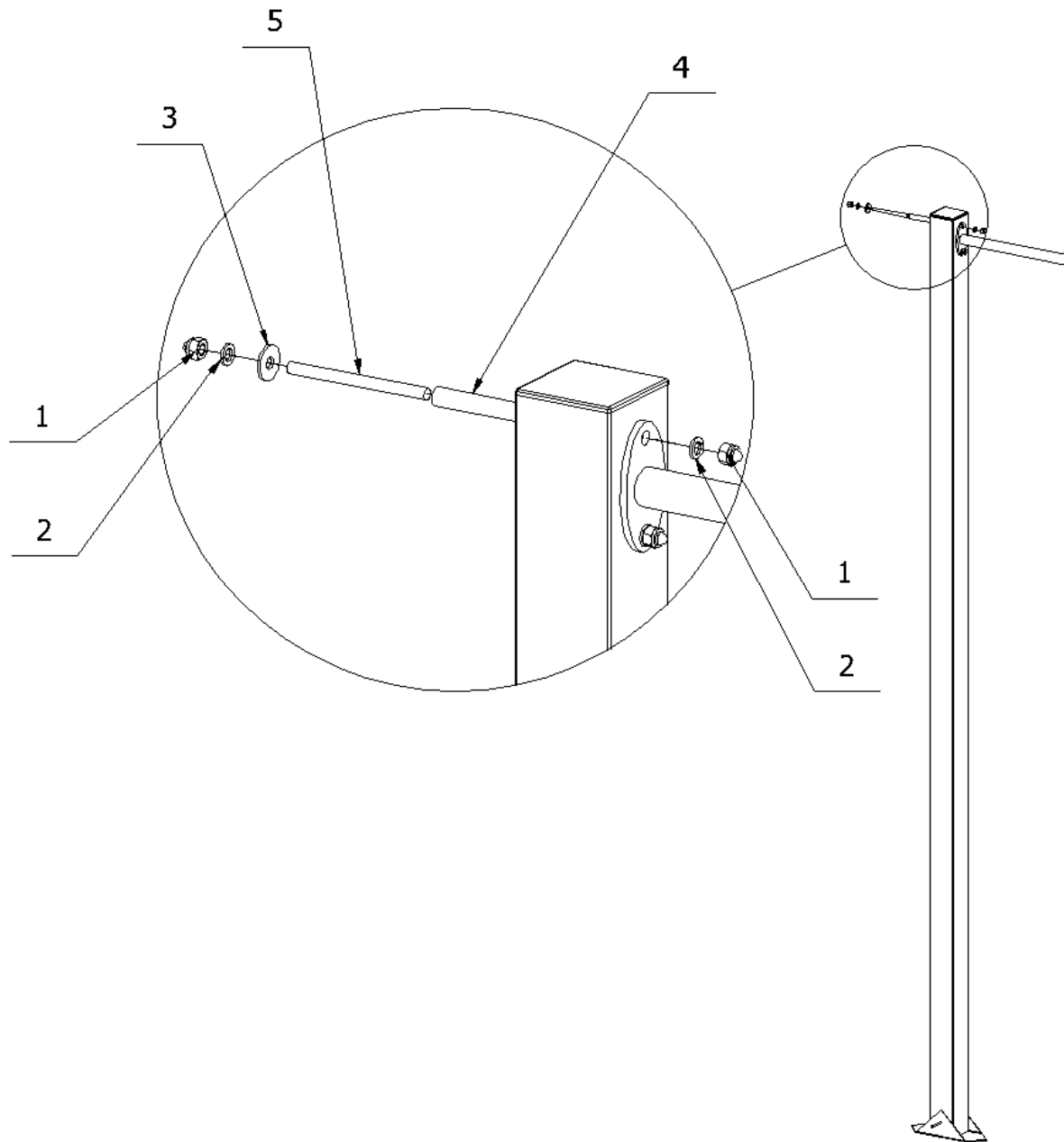

5	2	8816_130_A2
4	2	R_8813_003
3	2	ISO7093_10_A2
2	4	DIN127_10_A2
1	4	DIN986_M10_A2
Nr.	Il.	Nr Rys./Normy

1524

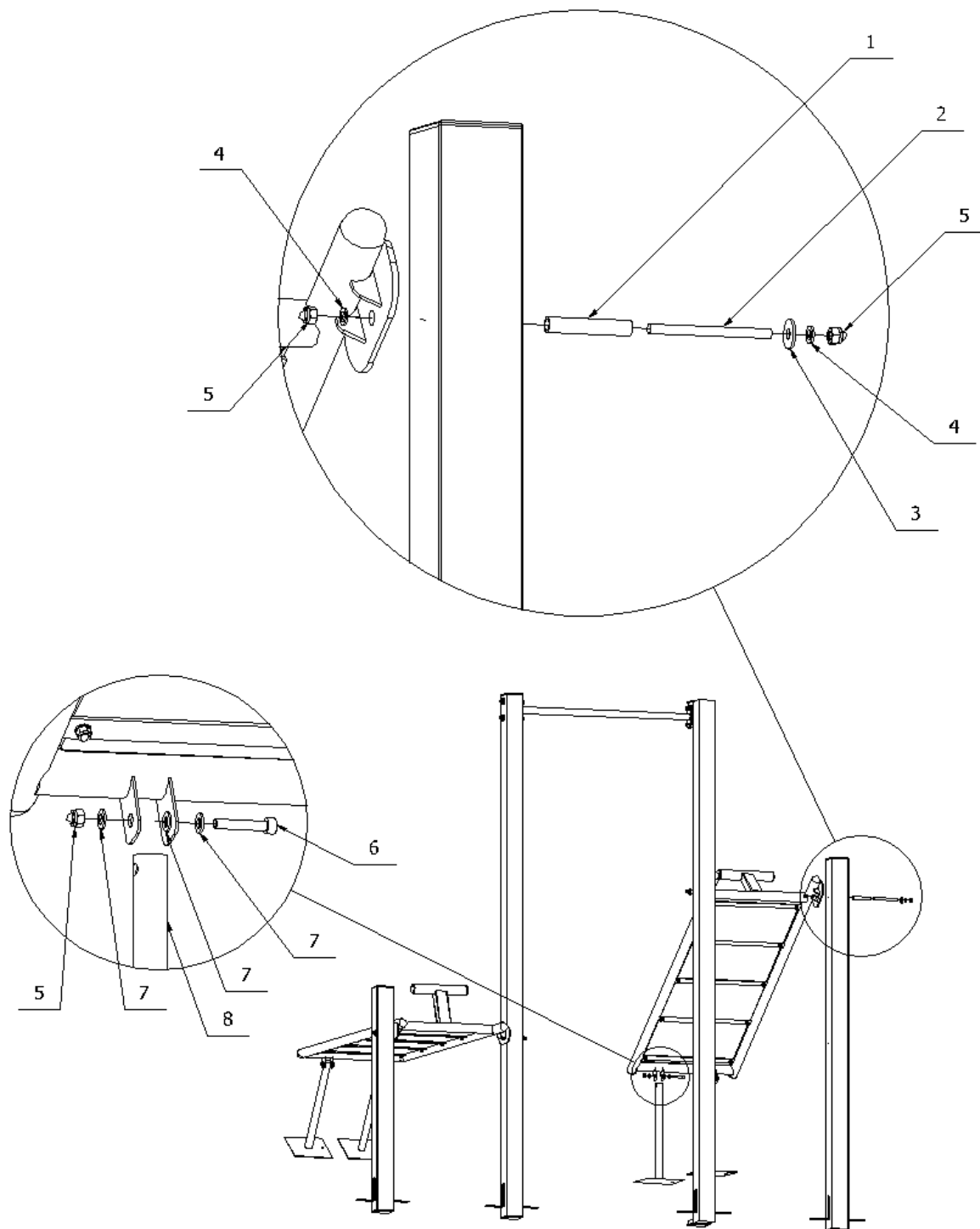

8	2	L1524_002
7	6	ISO7089_10_A2
6	2	ISO4762_M10x55_A2
5	16	DIN986_M10_A2
4	16	DIN127_10_A2
3	8	ISO7093_10_A2
2	8	8816_130_A2
1	8	R_8813_003
Nr.	Il.	Nr Rys./Nomy