



PL	INSTRUKCJA MONTAŻU	Nazwa	Action4Kids J8118	Nr kat.	1906
ENG	ASSEMBLY INSTRUCTIONS	Product	Action4Kids J8118	Cat. no.	
DEU	MONTAGEANLEITUNG	Name	Action4Kids J8118	Art.-Nr.	
FRA	INSTRUCTIONS D'INSTALLATION	Catégorie	Action4Kids J8118	Référence.	

1906



Wiek użytkowników Age of users Altersgruppe	Ilość użytkowników Number of users Anzahl der Benutzer Nombre d'utilisateurs	Przeznaczenie urządzenia Purpose of device Bestimmung des Spielgerätes	Zgodność z normą In accordance with the standard Geltende Norm
3-14	7	do zabawy na zewnątrz for outdoor playing zum draußen Spielen	PN-EN 1176-1:2017
NOVUM Sp. z o.o. Sp. k. ul. Bolesława Chrobrego 1, 12-100 Szczytno		e-mail: <a href="mailto:biuro@novumedukacja.pl">biuro@novumedukacja.pl</a> <a href="http://www.novumedukacja.pl">www.novumedukacja.pl</a>	
NOVUM Sp. z o.o. Sp. k. ul. Bolesława Chrobrego 1, 12-100 Szczytno		e-mail: <a href="mailto:eksport@novumgrom.com">eksport@novumgrom.com</a> <a href="http://www.novum4kids.com">www.novum4kids.com</a>	
NOVUM Deutschland GmbH, Schiffgesweg 11, 50259 Pulheim		e-mail: <a href="mailto:service@novum4kids.de">service@novum4kids.de</a> <a href="http://www.novum4kids.de">www.novum4kids.de</a>	
NOVUM DIRECT France Centre Commerciale La Samiane 01290 CROTTET		e-mail: <a href="mailto:contact@novum-direct.fr">contact@novum-direct.fr</a> <a href="http://www.novum-direct.fr">www.novum-direct.fr</a>	

**UWAGA / WARNING / ACHTUNG / ATTENTION:**

**PL** Jeżeli w zestawie występuje zjeżdżalnia, zestaw należy posadowić w taki sposób, aby ślizg zjeżdżalni znajdował się od strony północnej, czyli od strony nienasłonecznionej, aby zapobiegać nadmiernemu nagrzewaniu się ślizgu.

**ENG** If there is a slide in the set, it should be installed from the north, poorly sunny side to avoid possible hazards (burns) through direct skin contact.

**DEU** Wenn eine Spielplatzanlage eine Rutsche enthält, sollte diese Anlage so platziert werden, dass die Rutsche sich auf der Nordseite befindet, dh. auf der schattigen Seite, um übermäßige Erwärmung der Rutschbahn zu vermeiden.

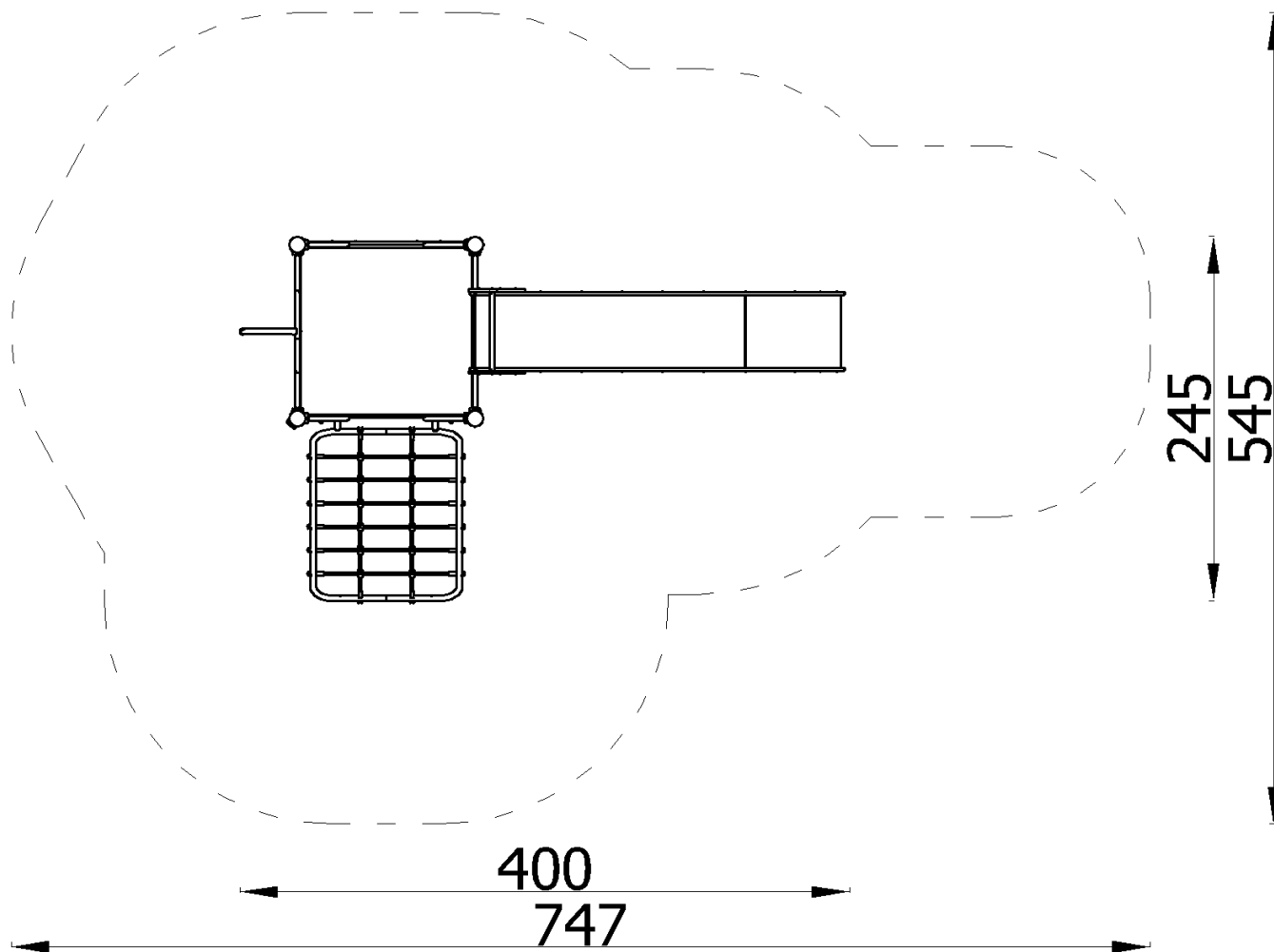

Montaż zgodnie z planem zagospodarowania terenu.  
 Installation in accordance with the land development plan.  
 Montage gemäß dem Flächennutzungsplan

Bezpieczna nawierzchnia / Safe surface / Safe Oberfläche / Surface sûre

Strefa Zone Zone Zone	Max. wysokość upadku Max. fall height Max. Fallhöhe Max. hauteur de chute	Pole powierzchni Surface area Fläche Surface	Obwód strefy bezpiecz. Perimeter security zone Umkreis der Fallschutzfläche Zone de périmètre de sé.
A	1,50 m	28,50 m <sup>2</sup>	21,30 m
B	-	-	
C	-	-	

Nawierzchnia / Safe surface / Fallschutzbelag / fr			1906
	Materiał Material Material	Min. wysokość warstwy Min. layer thicknesses Min. Schichtöhe	
h<0,6 m	Beton / Concrete / Beton Nawierzchnia bitumiczna / Bituminous surfacing / Bituminöse Oberfläche		
h<1 m	Gleba / Topsoil / Boden Darıń / Turf / Grasnarbe		
h<2 m	Kora / Bark / Borke	20÷80 mm	300
	Wióry / Wood chips / Holzhackschnitzel	5÷30 mm	
	Piasek / Sand / Sand Żwir / Gravel / Kies	0,25÷8 mm	
h<3 m	Kora / Bark / Borke	20÷80 mm	400
	Wióry / Wood chips / Holzhackschnitzel	5÷30 mm	
	Piasek / Sand / Sand Żwir / Gravel / Kies	0,25÷8 mm	
h<3 m	Nawierzchnia syntetyczna / Synthetic granulates / Synthetische Oberfläche	wg danych producenta acc. to the manufacturer's data nach Angaben des Herstellers	

Posadowienie / Foundation / Gründung / Fondation	1906
--	------

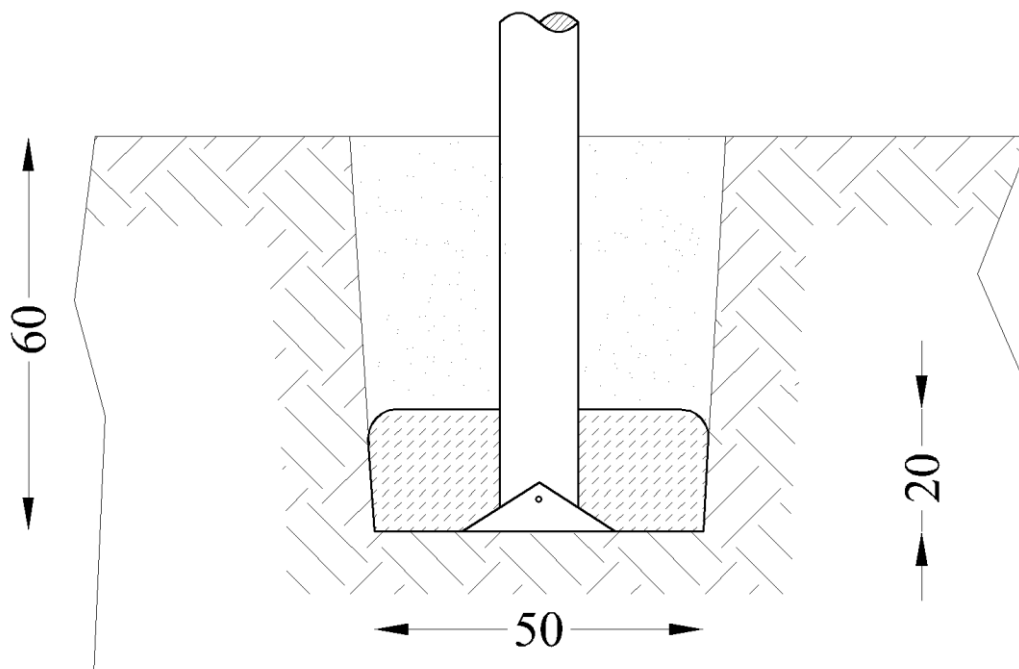

Beton / Concrete / Beton: **C16/20** - **0,36 m<sup>3</sup>**

W celu kontroli fundamentów należy usunąć nawierzchnię bezpieczną / piasek / żwir etc.  
 In order to control the foundations, remove the safe surface (sand, gravel, etc.)  
 Um die Fundamente zu überprüfen, entfernen Sie den Fallschutzbelag: Sand/ Kies etc.

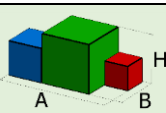
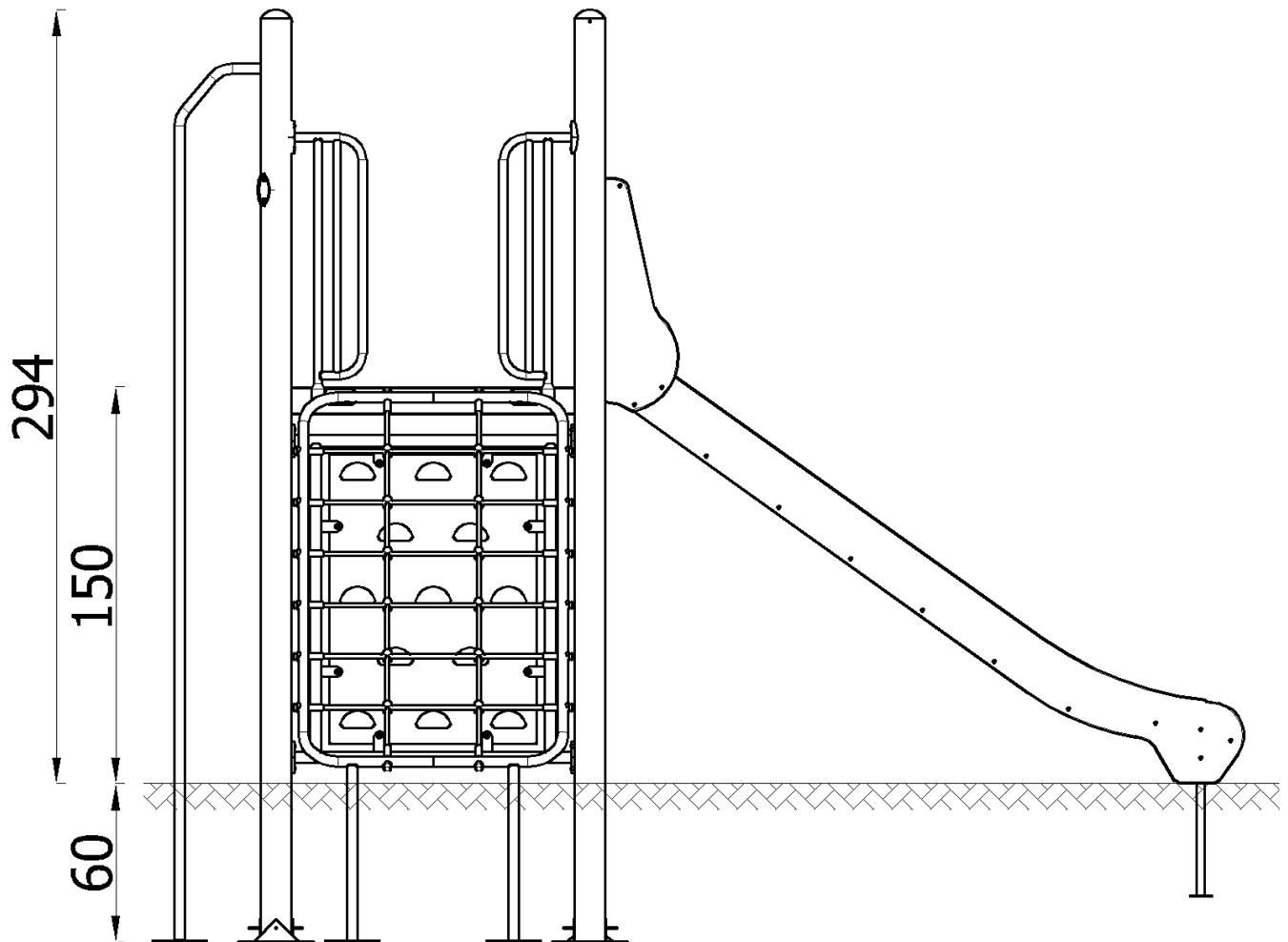

4x2,45x2,94  
(AxBxH) [m]

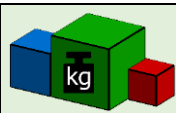

199 kg

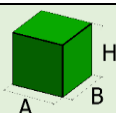

0,1x0,1x3,54  
(AxBxH) [m]





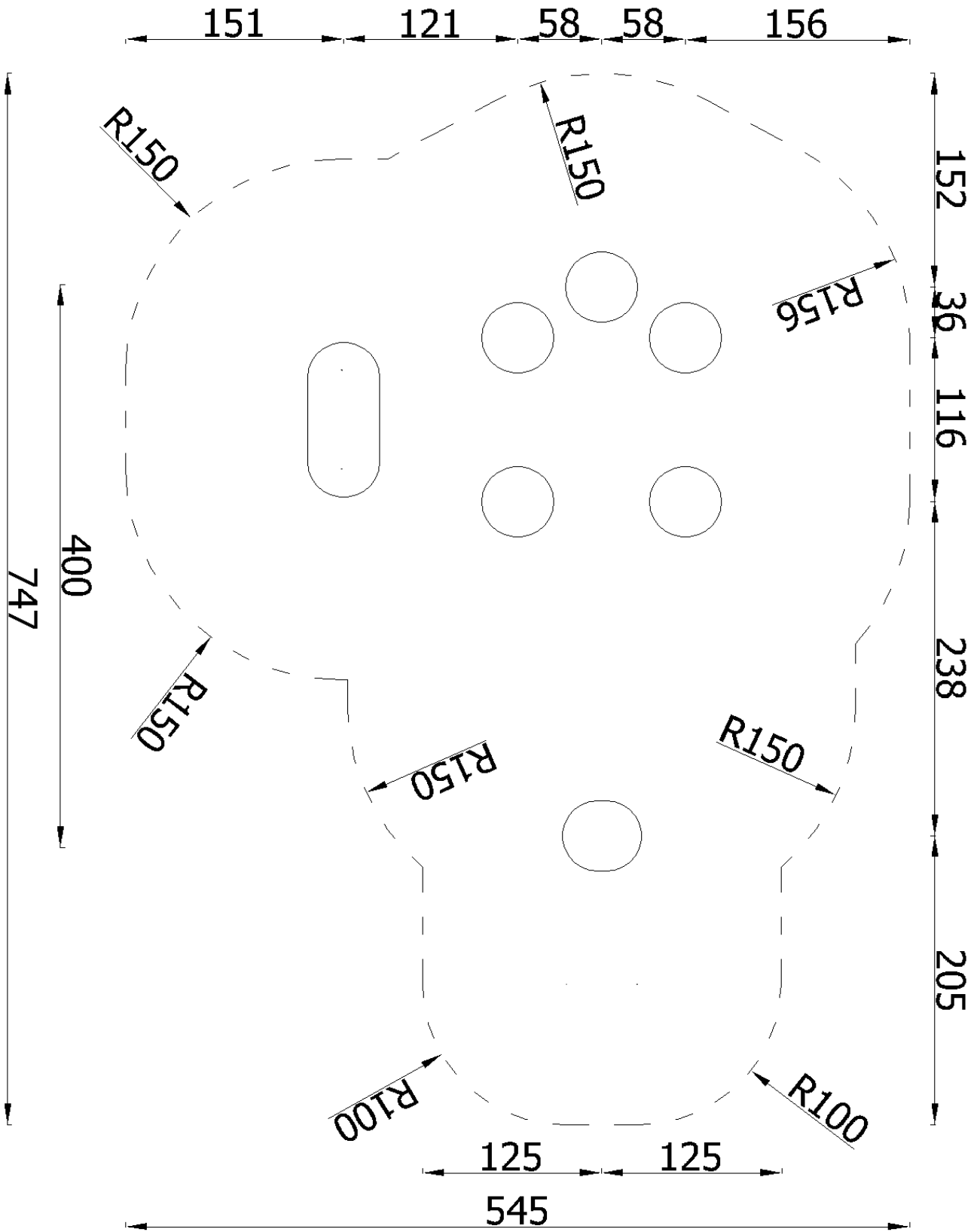

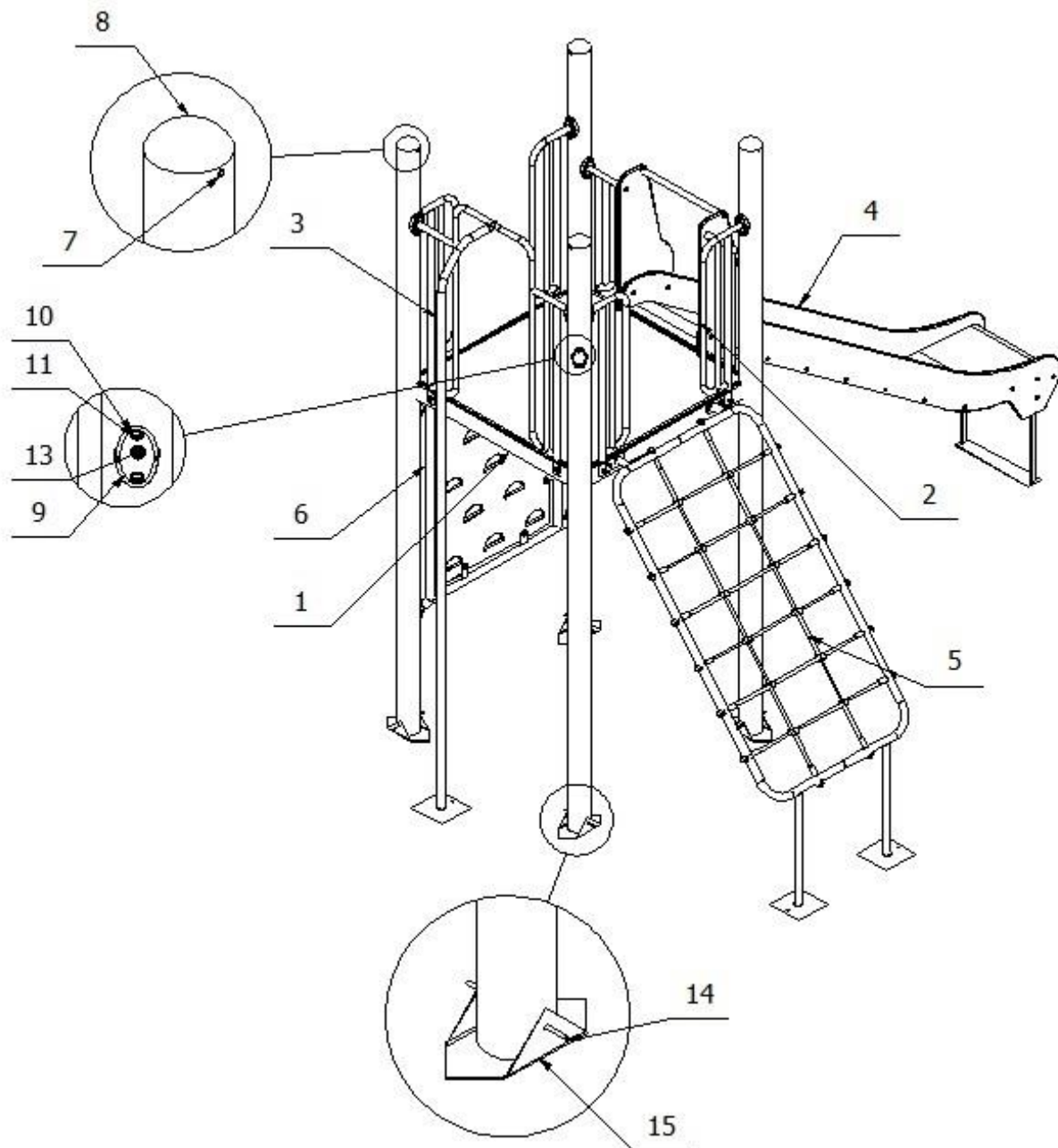
66 kg





Części zamienne dostępne u producenta. Stosować klej do gwintów w połączeniach śrubowych.  
Spare parts available from the manufacturer. Use thread glue in screw connections.  
Ersatzteile beim Hersteller erhältlich. Gewindekleber für Schraubverbindungen verwenden.

15	Błacha 3x283x283	B_8802_025	4				
14	Pręt 6x200 mm	8850_002	4				
13	Zestaw słupów wierconych	1906/1 - 1906/4	1 kpl.				
12	Tabliczka znamionowa pionowa	8918_002	1				
11	Śruba z łbem kulistym Pin torx	ISO7380_M10x25_PT_A2	2				
10	Podkładka	ISO7089_10_A2	2				
9	Wkładka łezka wklęsła	8919_001	2				
8	Zaślepka kołpakowa rury 114,3	8912_120	4				
7	Nit zrywalny	DIN7337_A5x10	8				
6	Ścianka wspinaczkowa A-Q015	23206	1				
5	Wejście linowe 150 A4K	23247	1				
4	Zjeżdżalnia 150 A4K	2166	1				
3	Rura strażacka 150 A4K	23252	1				
2	Wejściówka niższa A4K	23220	2				
1	Podest kwadratowy A4K	20104	1				
Lp. Art. Nr.	No. Rep.	Nazwa części Teilename	Part name Nom de la pièce	Nr części Teile-Nr	Part No. Partie No.	Ilość Anzahl	Quantity Nombre

															
								5 m	30 m						
															
2,5 m				60 cm	100 cm										
															
				7 mm								13 mm	17 mm	19 mm	24 mm
															
13 mm	17 mm	19 mm	24 mm	4 mm	5 mm	6 mm	8 mm	T40				T45			
															

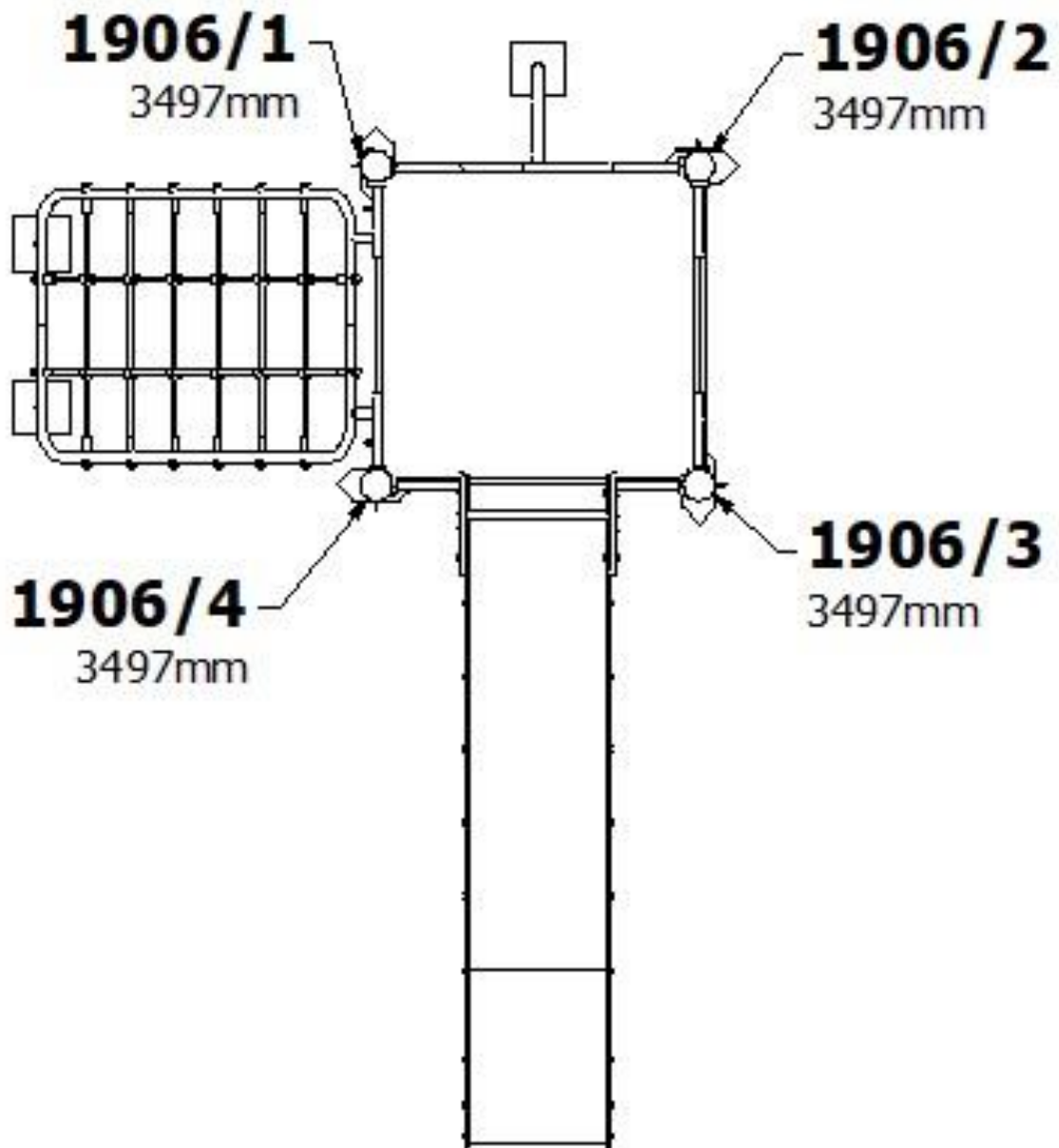

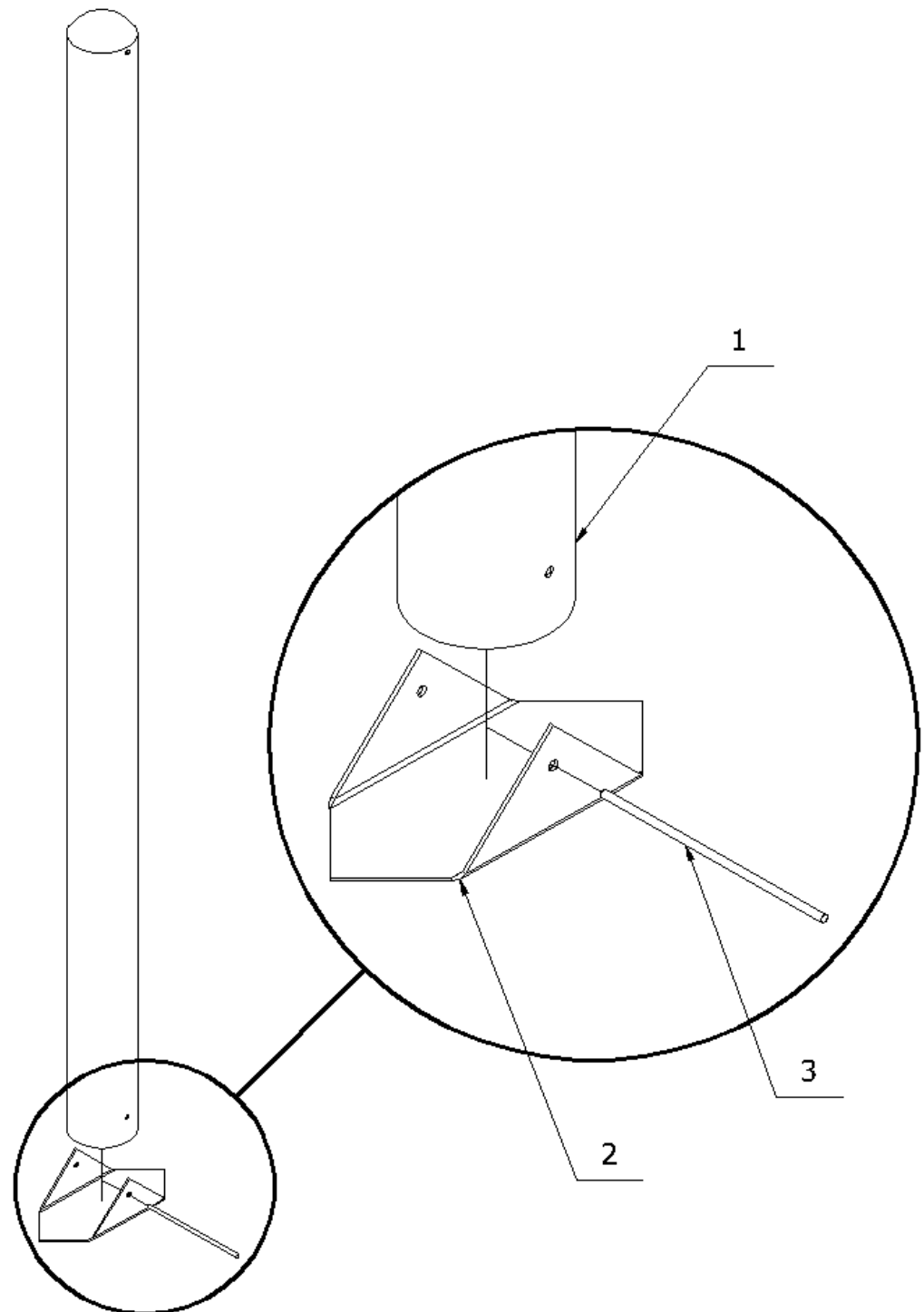

**SŁUP / POLE**

3	8850_002	1
2	B_8802_025	1
1	SŁUP/ POLE	1
Nr.	Nr Rys./Normy	Ilość

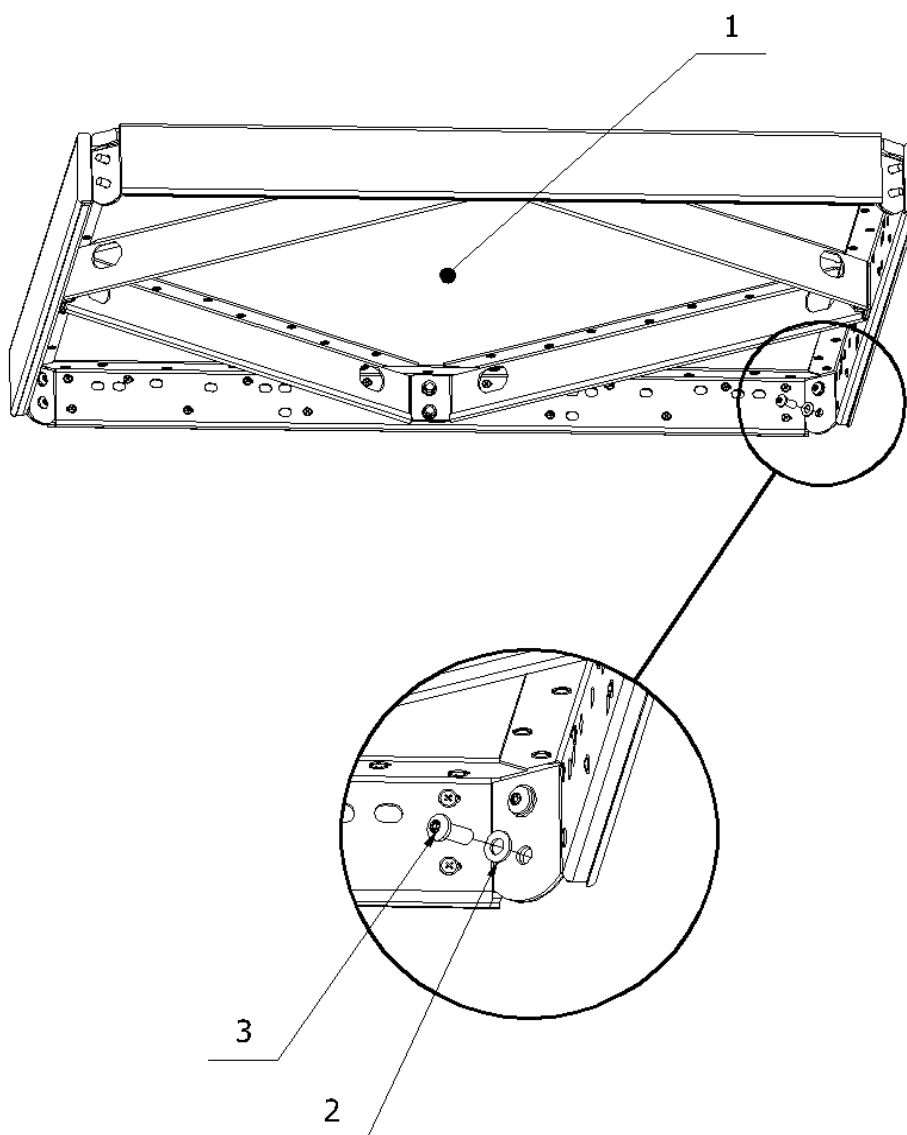
**20104**

3	ISO7380_M10x25_PT_A2	8
2	ISO7089_10_A2	8
1	20104	1
Nr.	Nr Rys./Normy	Ilość

# 23220

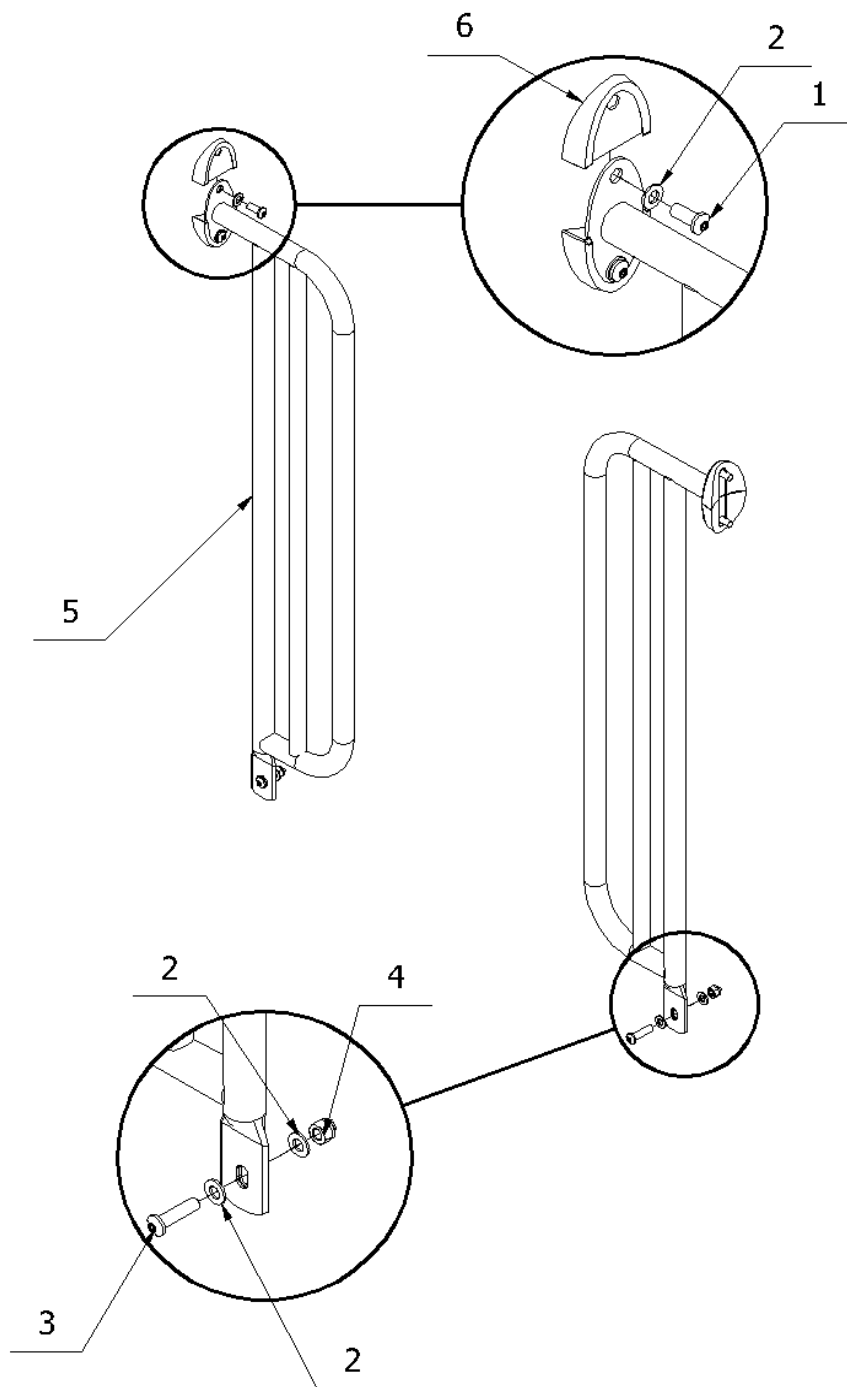

6	8919_001	4
5	L23220_001	2
4	DIN986_M10_A2	2
3	ISO7380_M10x40_PT_A2	2
2	ISO7089_10_A2	8
1	ISO7380_M10x25_PT_A2	4
Nr.	Nr Rys./Normy	Ilość

# 23252

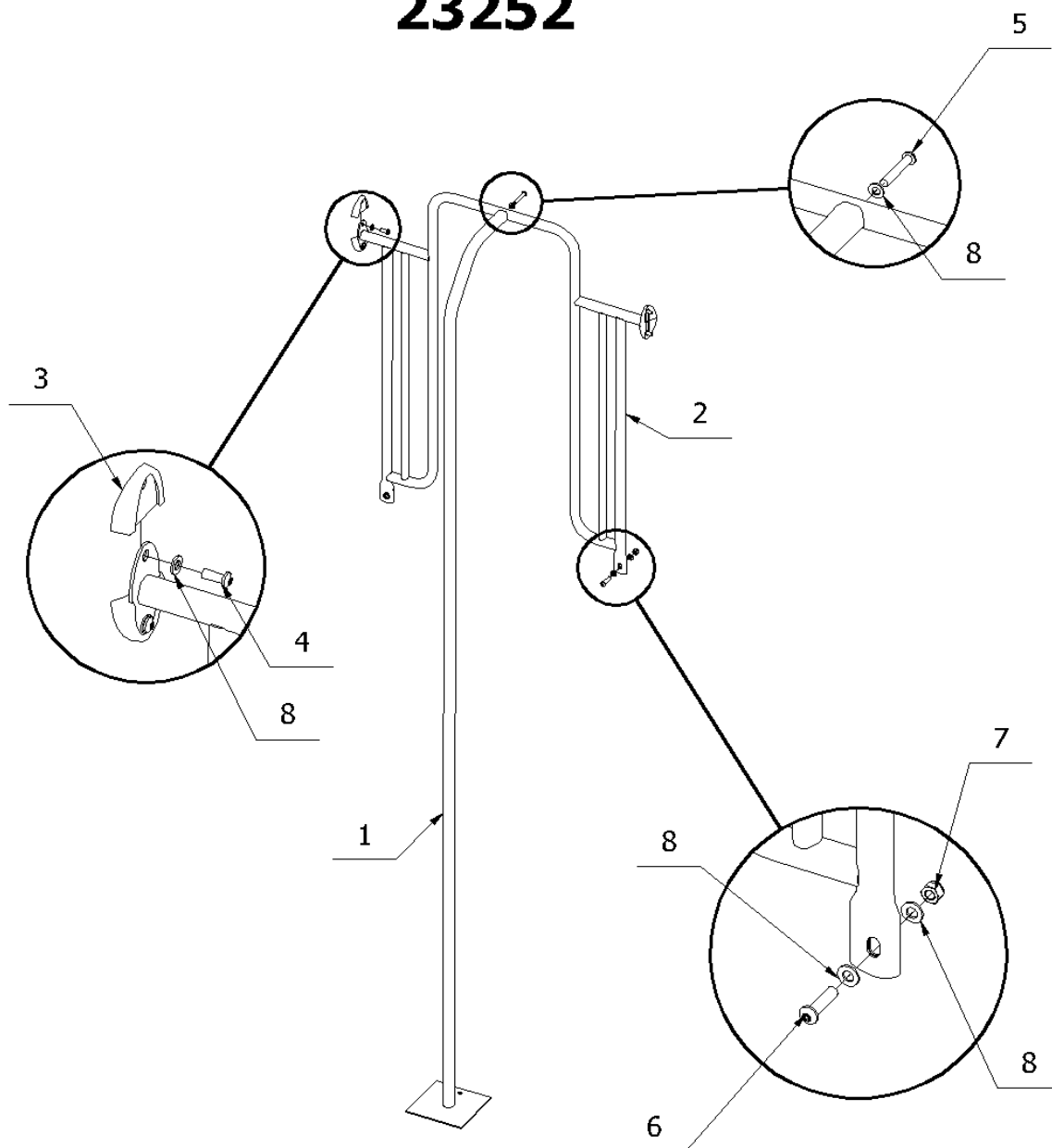

8	ISO7089_10_A2	9
7	DIN986_M10_A2	2
6	ISO7380_M10x40_PT_A2	2
5	ISO7380_M10x60_PT_A2	1
4	ISO7380_M10x25_PT_A2	4
3	8919_001	4
2	L23239_001	1
1	L23252_001	1
Nr.	Nr Rys./Normy	Ilość

# 2166

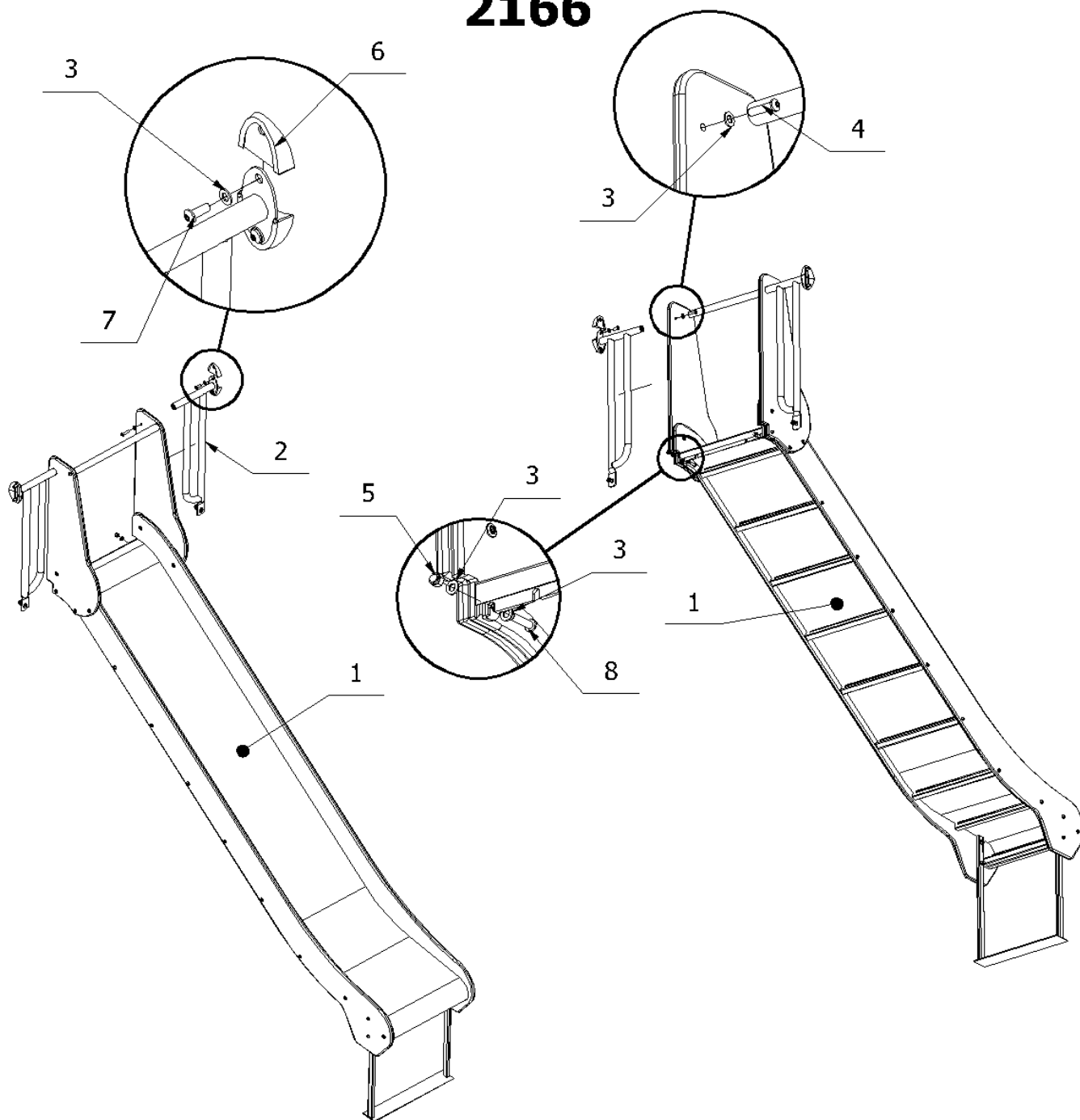

8	ISO7380_M10x45_PT_A2	2
7	ISO7380_M10x25_PT_A2	4
6	8919_001	4
5	DIN986_M10_A2	4
4	ISO7380_M10x40_PT_A2	4
3	ISO7089_10_A2	14
2	23170	2
1	2166	1
Nr.	Nr Rys./Normy	Ilość

# 23247

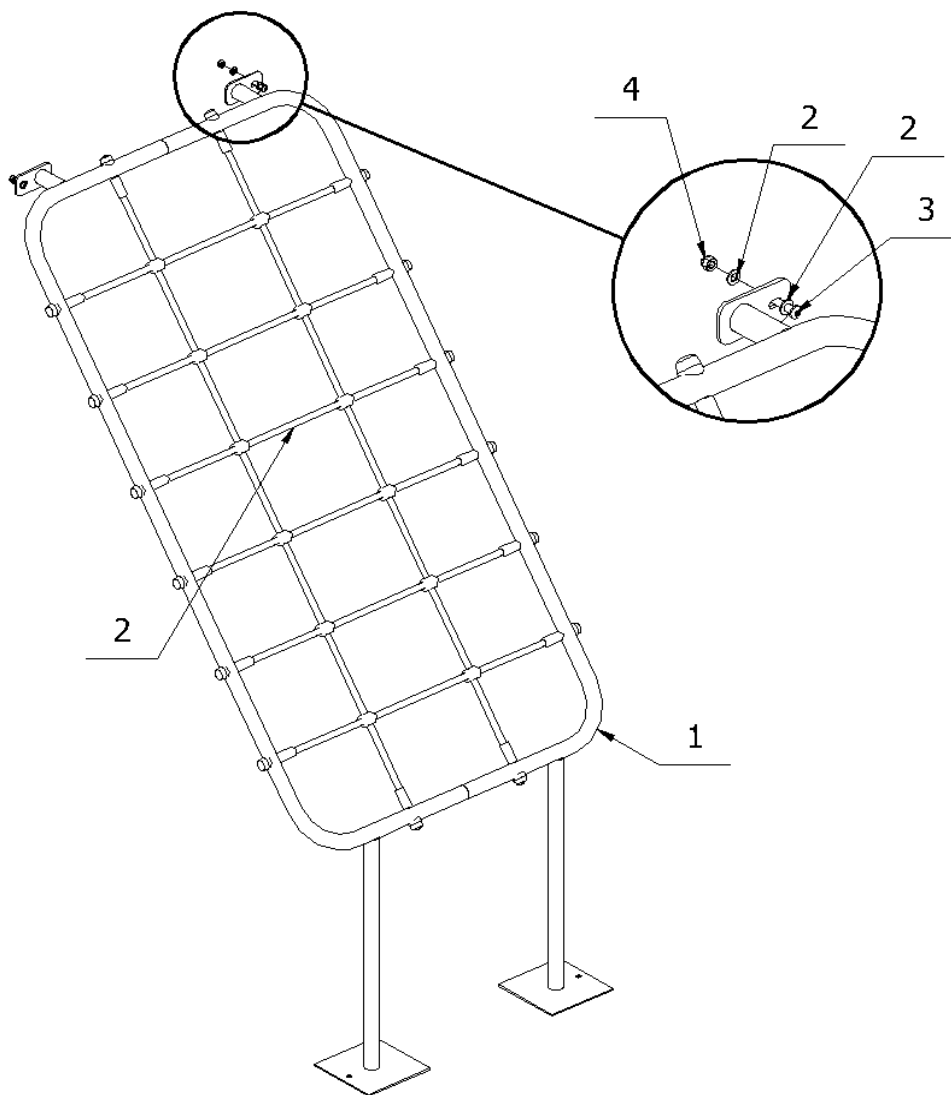

4	DIN986_M10_A2	2
3	ISO7380_M10x40_PT_A2	2
2	ISO7089_10_A2	4
1	L23247_001 + L23247_002	1
Nr.	Nr Rys./Normy	Ilość

# 23206

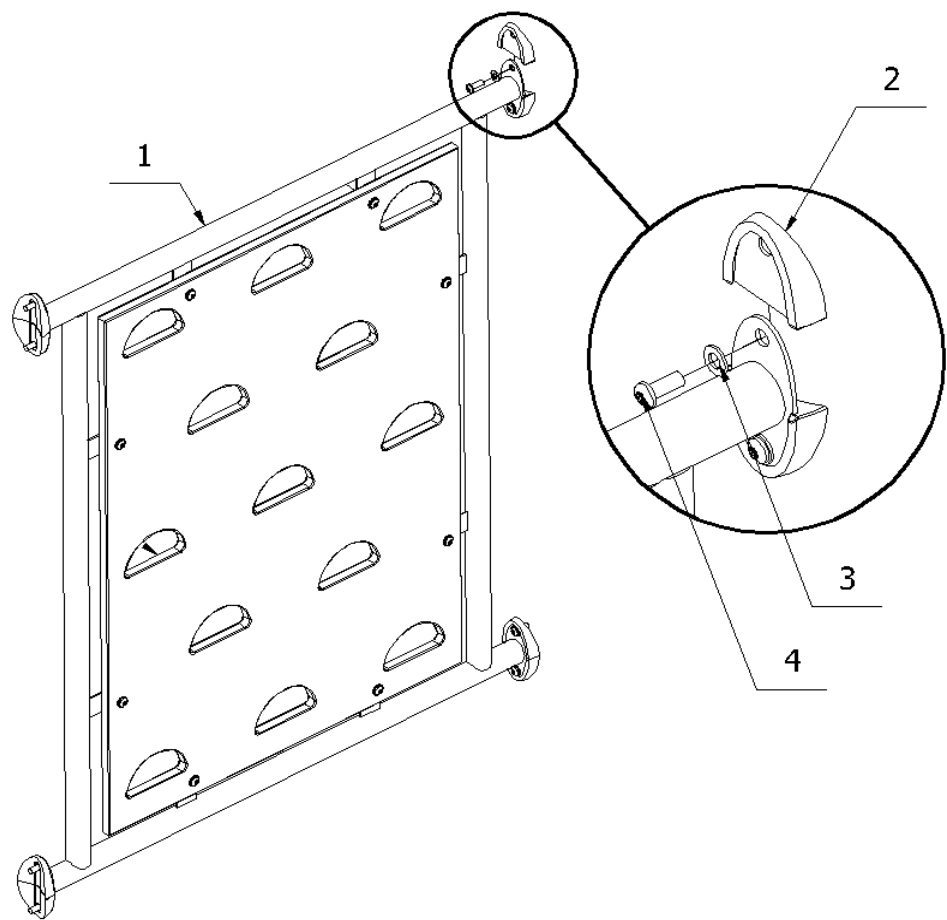

4	ISO7380_M10x25_PT_A2	8
3	ISO7089_10_A2	8
2	8919_001	8
1	L23206_001 + E_23206_001	1
Nr.	Nr Rys./Normy	Ilość