

PL	INSTRUKCJA MONTAŻU	Nazwa	Action4Kids MKP-J8004-002	Nr kat.	1922
ENG	ASSEMBLY INSTRUCTIONS	Product	Action4Kids MKP-J8004-002	Cat. no.	
DEU	MONTAGEANLEITUNG	Name	Action4Kids MKP-J8004-002	Art.-Nr.	
FRA	INSTRUCTIONS D'INSTALLATION	Catégorie	Action4Kids MKP-J8004-002	Référence.	

1922



Wiek użytkowników Age of users Altersgruppe	Ilość użytkowników Number of users Anzahl der Benutzer Nombre d'utilisateurs	Przeznaczenie urządzenia Purpose of device Bestimmung des Spielgerätes	Zgodność z normą In accordance with the standard Geltende Norm
3-14	7	do zabawy na zewnątrz for outdoor playing zum draußen Spielen	PN-EN 1176-1:2017
NOVUM Sp. z o.o. Sp. k. ul. Bolesława Chrobrego 1, 12-100 Szczytno		e-mail: biuro@novumedukacja.pl www.novumedukacja.pl	
NOVUM Sp. z o.o. Sp. k. ul. Bolesława Chrobrego 1, 12-100 Szczytno		e-mail: eksport@novumgrom.com www.novum4kids.com	
NOVUM Deutschland GmbH, Schiffgesweg 11, 50259 Pulheim		e-mail: service@novum4kids.de www.novum4kids.de	
NOVUM DIRECT France Centre Commerciale La Samiane 01290 CROTTET		e-mail: contact@novum-direct.fr www.novum-direct.fr	

UWAGA / WARNING / ACHTUNG / ATTENTION:

PL Jeżeli w zestawie występuje zjeżdżalnia, zestaw należy posadzić w taki sposób, aby ślizg zjeżdżałni znajdował się od strony północnej, czyli od strony nienasłonecznionej, aby zapobiegać nadmiernemu nagrzewaniu się ślizgu.

ENG If there is a slide in the set, it should be installed from the north, poorly sunny side to avoid possible hazards (burns) through direct skin contact.

DEU Wenn eine Spielplatzanlage eine Rutsche enthält, sollte diese Anlage so platziert werden, dass die Rutsche sich auf der Nordseite befindet, dh. auf der schattigen Seite, um übermäßige Erwärmung der Rutschbahn zu vermeiden.

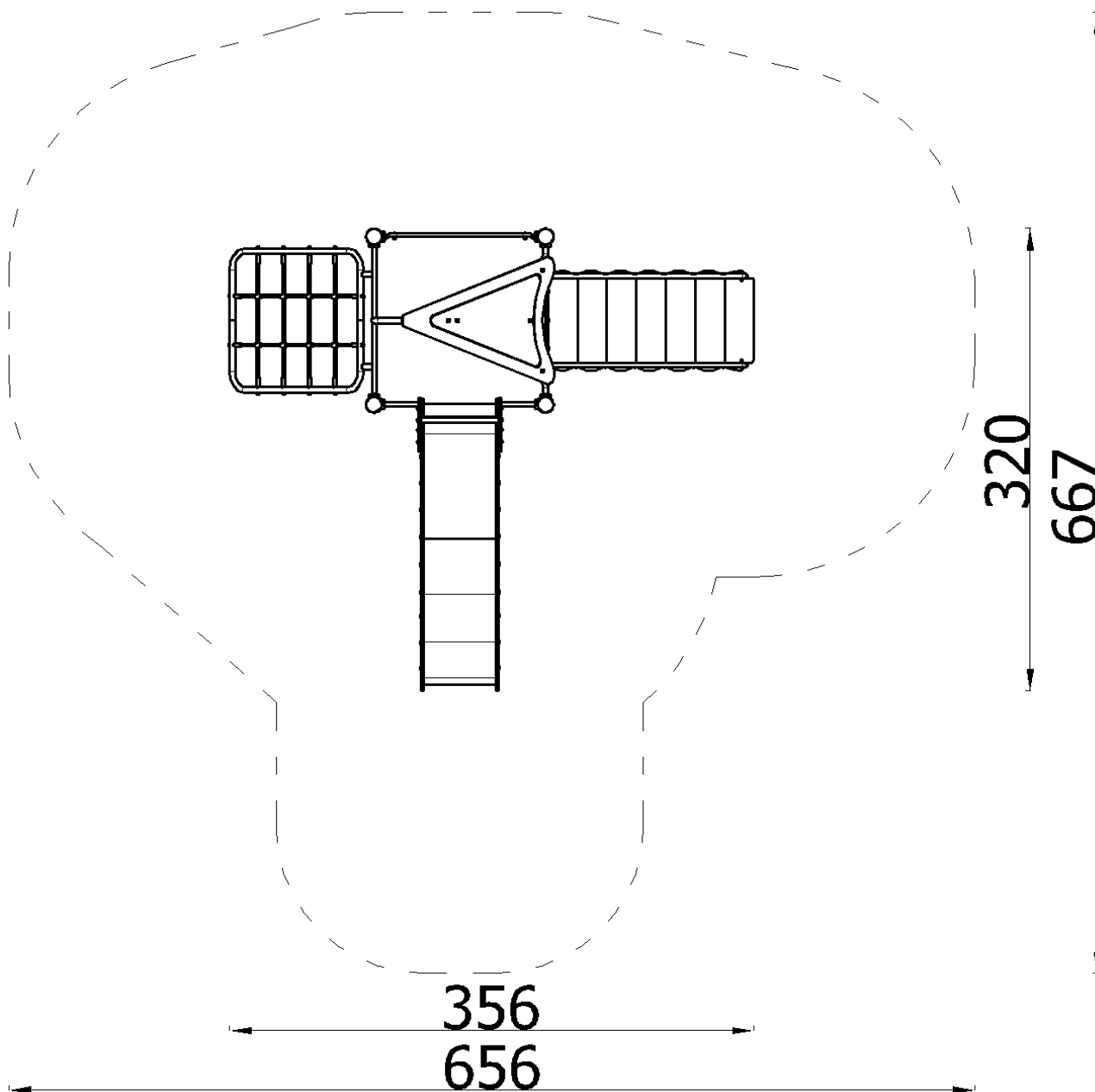

Montaż zgodnie z planem zagospodarowania terenu.
 Installation in accordance with the land development plan.
 Montage gemäß dem Flächennutzungsplan

Bezpieczna nawierzchnia / Safe surface / Safe Oberfläche / Surface sûre

Strefa Zone Zone Zone	Max. wysokość upadku Max. fall height Max. Fallhöhe Max. hauteur de chute	Pole powierzchni Surface area Fläche Surface	Obwód strefy bezpiecz. Perimeter security zone Umkreis der Fallschutzfläche Zone de périmètre de sé.
A	1,20 m	29,70 m ²	21,70 m
B	-	-	
C	-	-	

Nawierzchnia / Safe surface / Fallschutzbelag / fr			1922
	Materiał Material Material	Min. wysokość warstwy Min. layer thicknesses Min. Schichtöhe	
h<0,6 m	Beton / Concrete / Beton Nawierzchnia bitumiczna / Bituminous surfacing / Bituminöse Oberfläche		
h<1 m	Gleba / Topsoil / Boden Darń / Turf / Grasnarbe		
h<2 m	Kora / Bark / Borke	20÷80 mm	300
	Wióry / Wood chips / Holzhacksnitzel	5÷30 mm	
	Piasek / Sand / Sand Żwir / Gravel / Kies	0,25÷8 mm	
h<3 m	Kora / Bark / Borke	20÷80 mm	400
	Wióry / Wood chips / Holzhacksnitzel	5÷30 mm	
	Piasek / Sand / Sand Żwir / Gravel / Kies	0,25÷8 mm	
h<3 m	Nawierzchnia syntetyczna / Synthetic granulates / Synthetische Oberfläche	wg danych producenta acc. to the manufacturer's data nach Angaben des Herstellers	

Posadowienie / Foundation / Gründung / Fondation	1922
--	------

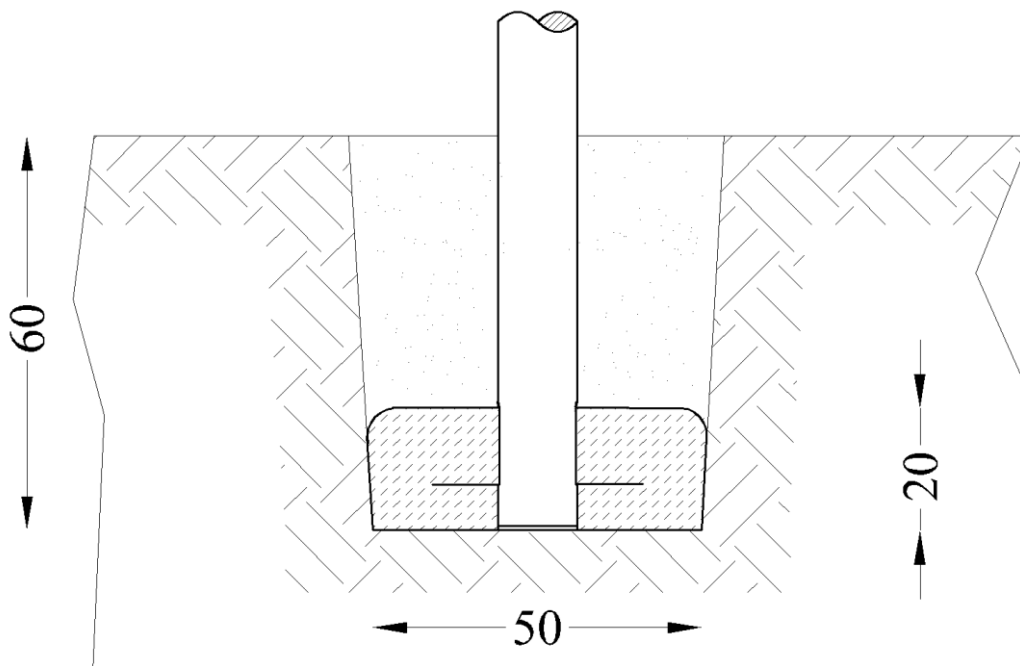

Beton / Concrete / Beton: **C16/20** - **0,4 m³**

W celu kontroli fundamentów należy usunąć nawierzchnię bezpieczną / piasek / żwir etc.

In order to control the foundations, remove the safe surface (sand, gravel, etc.)

Um die Fundamente zu überprüfen, entfernen Sie den Fallschutzbelag: Sand/ Kies etc.

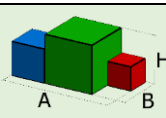
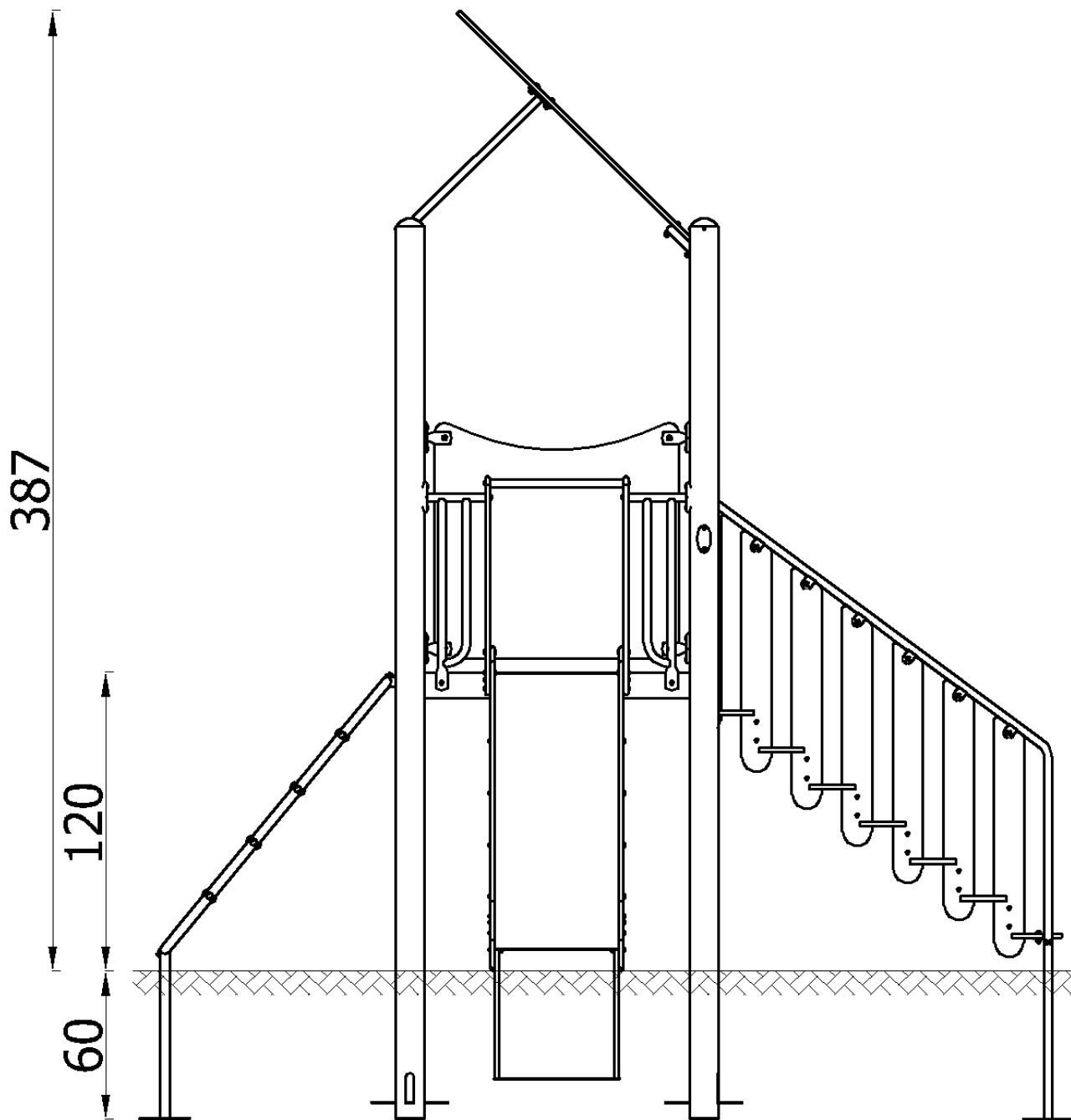

3,56x3,2x3,87
(AxBxH) [m]

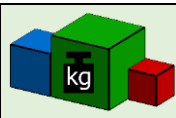

0 kg

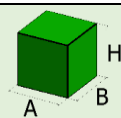

0,11x0,11x3,64
(AxBxH) [m]



0 kg

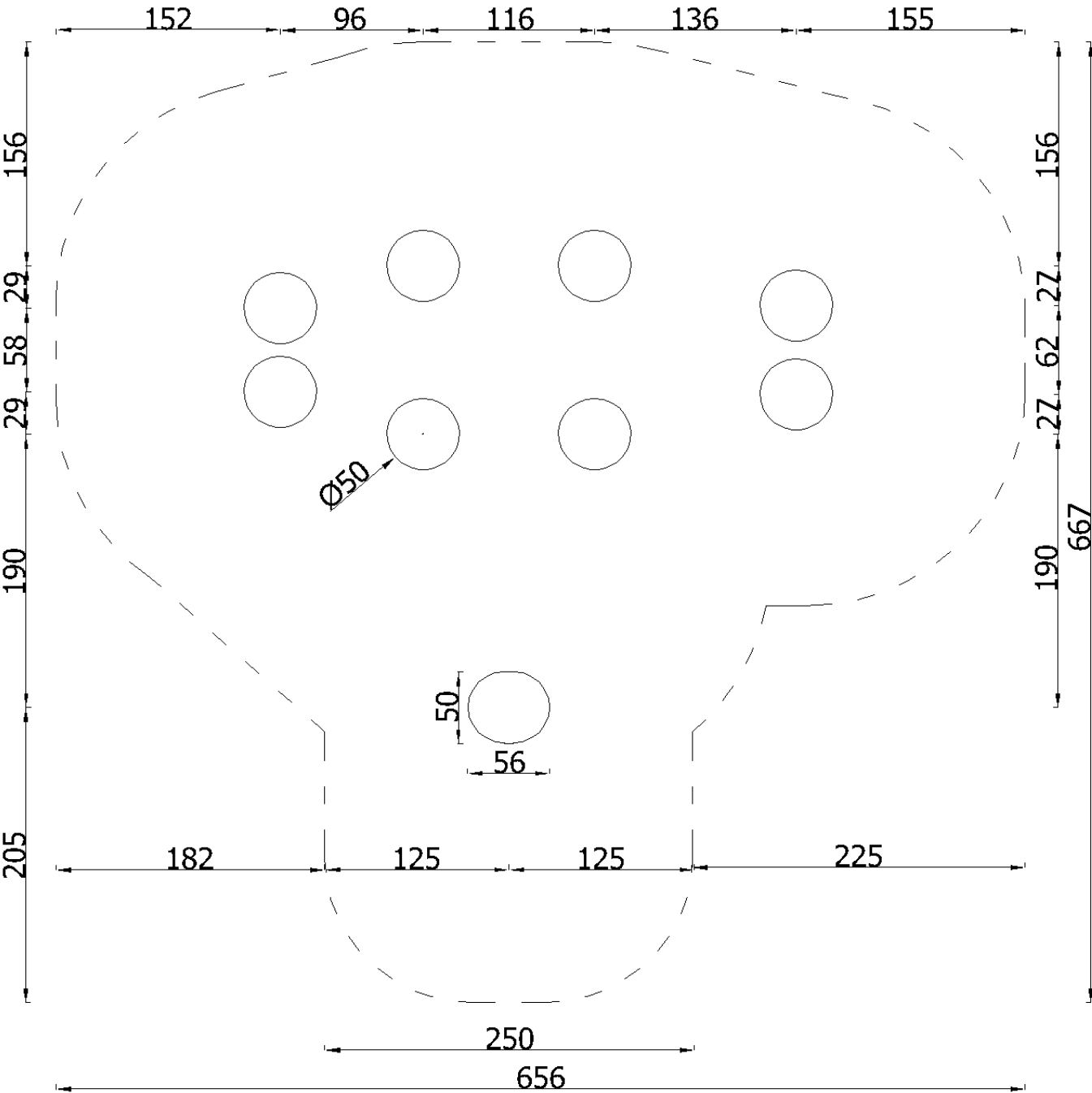

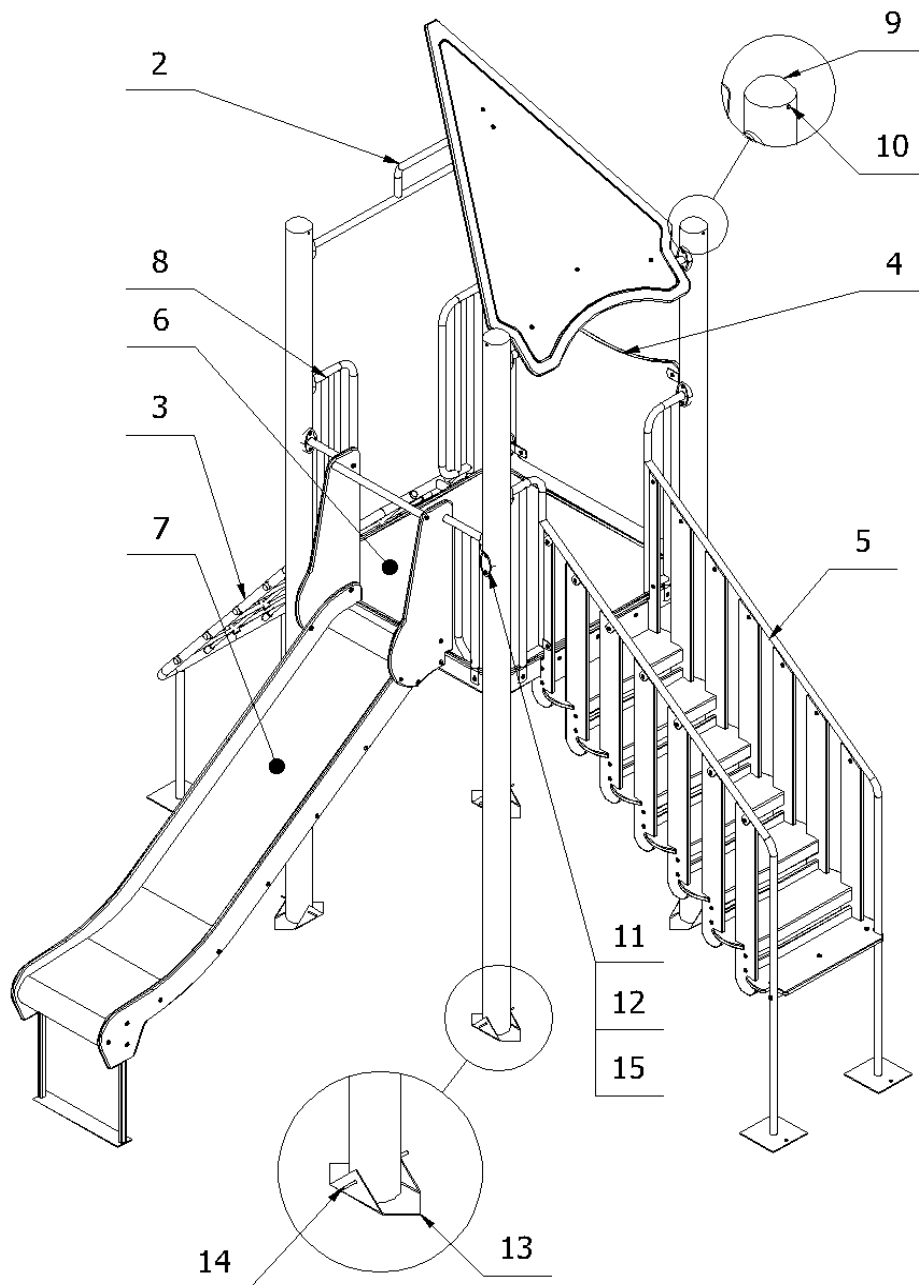



Części zamienne dostępne u producenta. Stosować klej do gwintów w połączeniach śrubowych.
Spare parts available from the manufacturer. Use thread glue in screw connections.
Ersatzteile beim Hersteller erhältlich. Gewindekleber für Schraubverbindungen verwenden.

15	Śruba z łbem podkładkowym	ISO7380_2_M8x16_A2	2				
14	Pręt 6x200 mm	8850_002	4				
13	Blacha 3x283x283	B_8802_025	4				
12	Tabliczka znamionowa pionowa	8918_002	1				
11	Wkładka łezka wklęsła	8919_001	2				
10	Nit zrywalny	DIN7337_A5x10	8				
9	Zaślepka kołpakowa rury 114,3	8912_120	4				
8	Wejściówka niższa A4K	23220N	1				
7	Zjeżdżalnia 120 A4K	2165N	1				
6	Podest kwadratowy A4K	20104N	1				
5	Schody A4K 120	23215N	1				
4	Panel A4K Novum trójkąty	2481N	1				
3	Wejście linowe 120 A4K	23238N	1				
2	Dach jednospadowy A4K	2522N	1				
1	Zestaw słupów wierconych	1922/1 - 1922/4	1 kpl.				
Lp. Art. Nr.	No. Rep.	Nazwa części Teilename	Part name Nom de la pièce	Nr części Teile-Nr	Part No. Partie No.	Ilość Anzahl	Quantity Nombre

Narzędzia / Tools / Handwerkzeug / Outils

1922

															
								5 m	30 m						
															
2,5 m				60 cm	100 cm										
															
				7 mm								13 mm	17 mm	19 mm	24 mm
															
13 mm	17 mm	19 mm	24 mm	4 mm	5 mm	6 mm	8 mm	T40				T45			
															

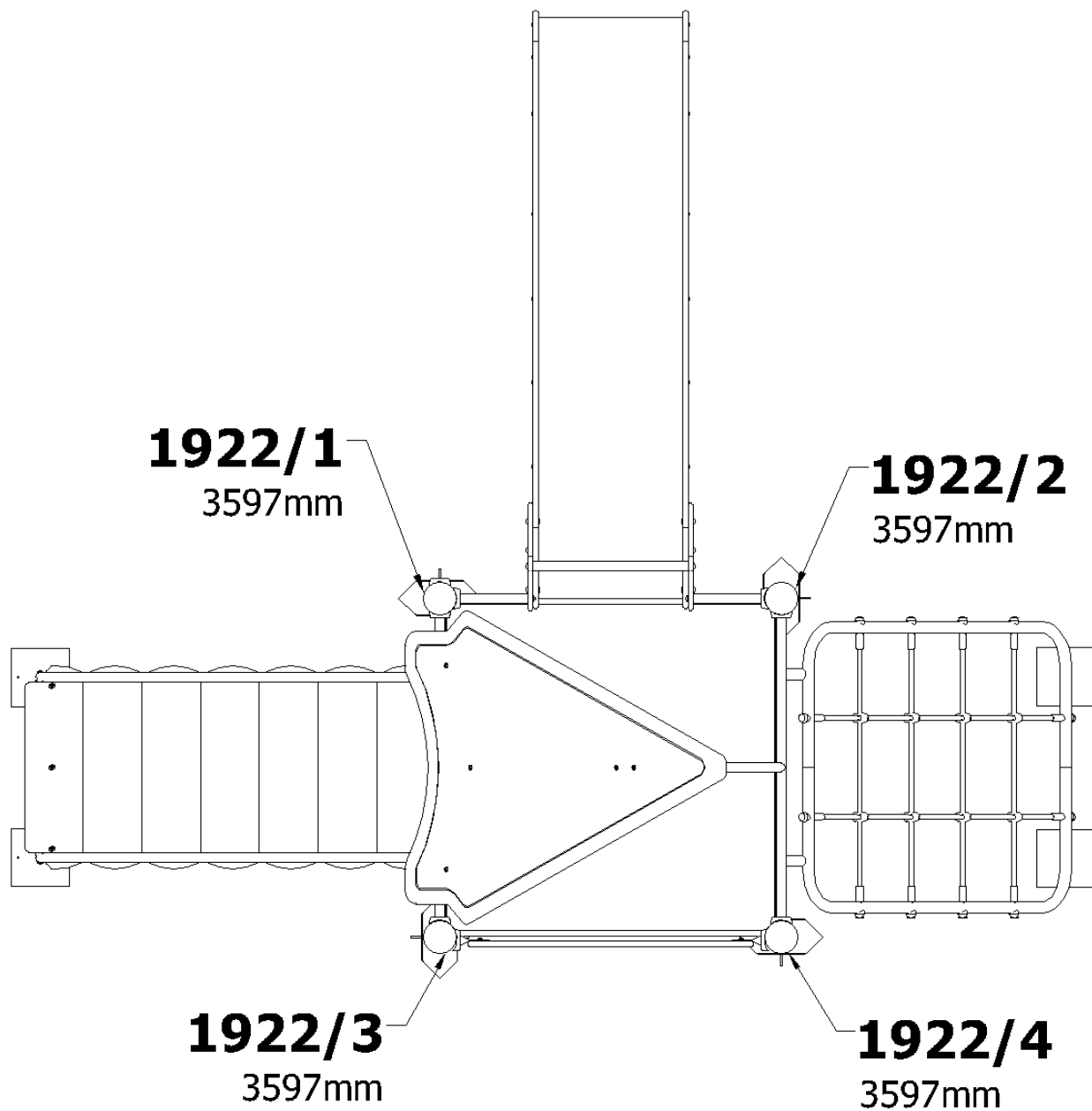

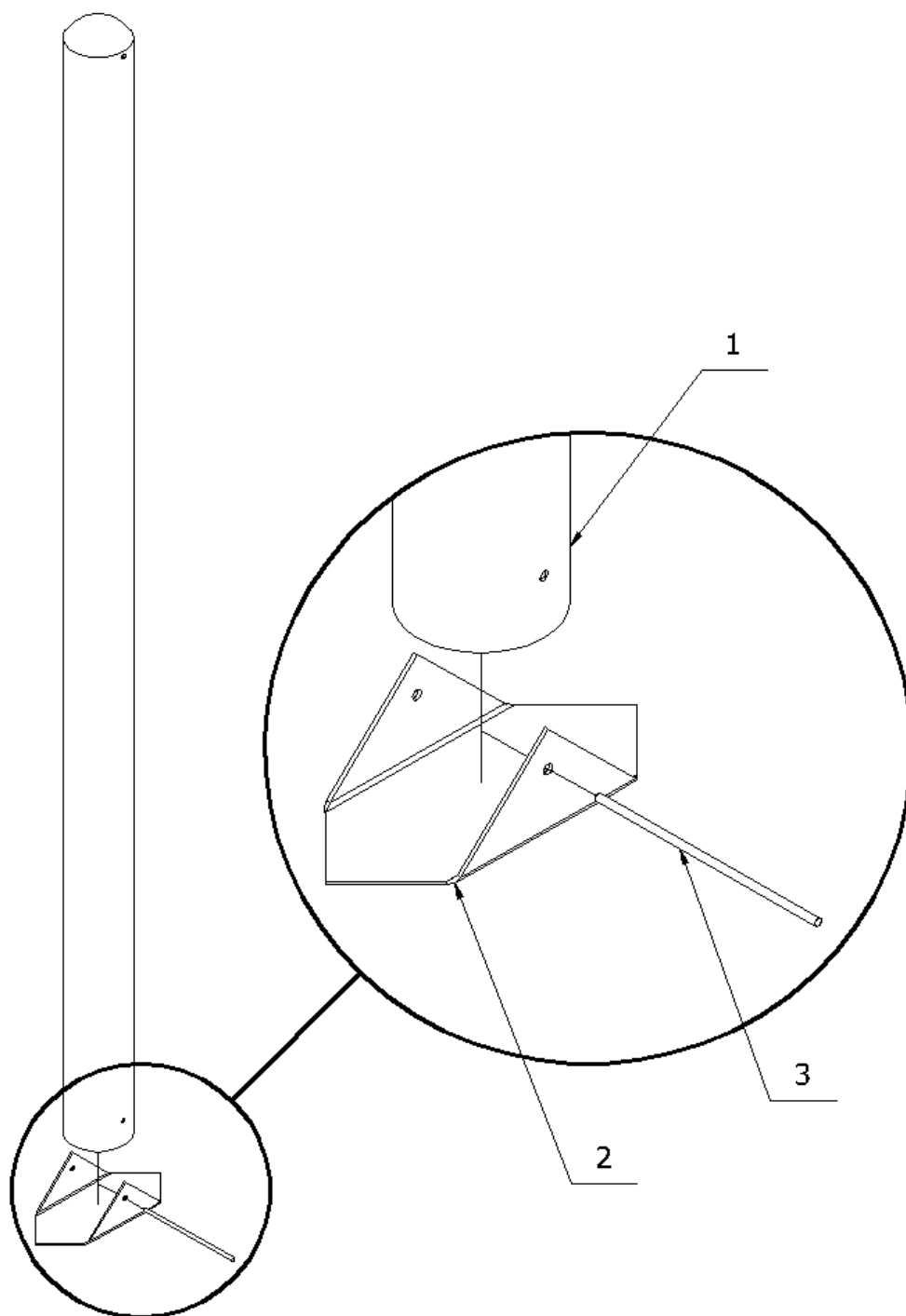
SŁUP / POLE

3	8850_002	1
2	B_8802_025	1
1	SŁUP/ POLE	1
Nr.	Nr Rys./Normy	Ilość

20104N

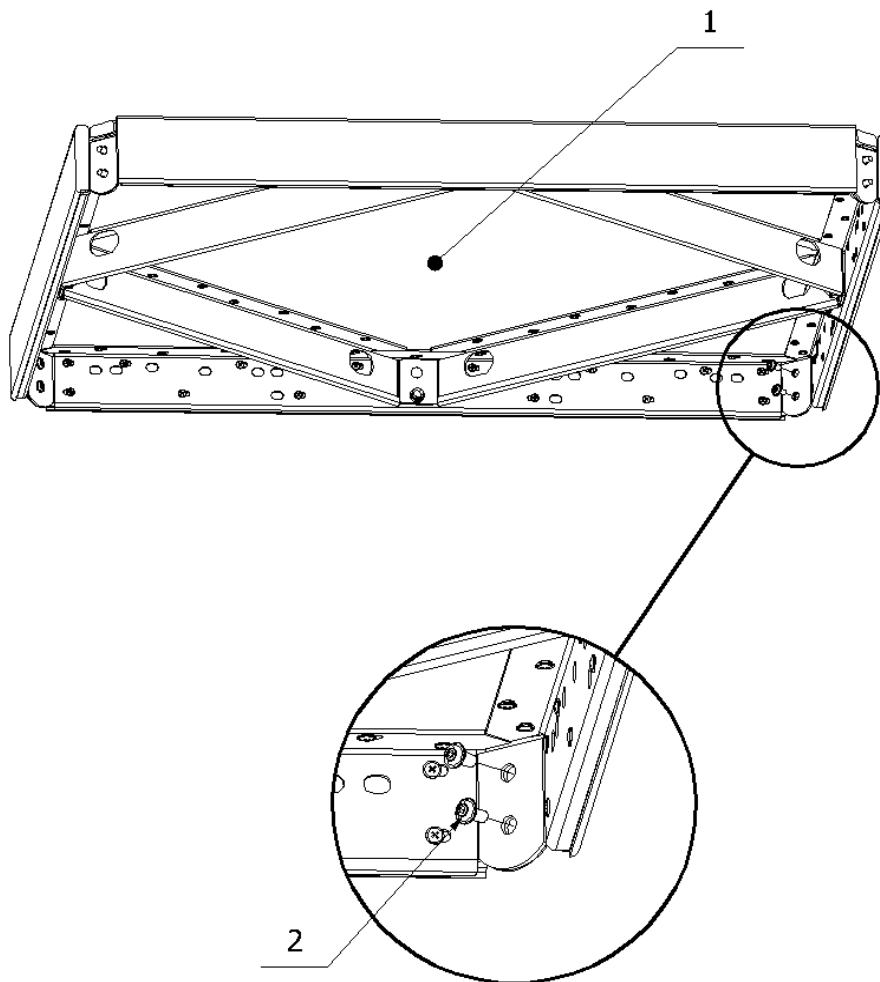

2	ISO7380_2_M8x16_A2	8
1	20104	1
Nr.	Nr Rys./Normy	Ilość

2522N

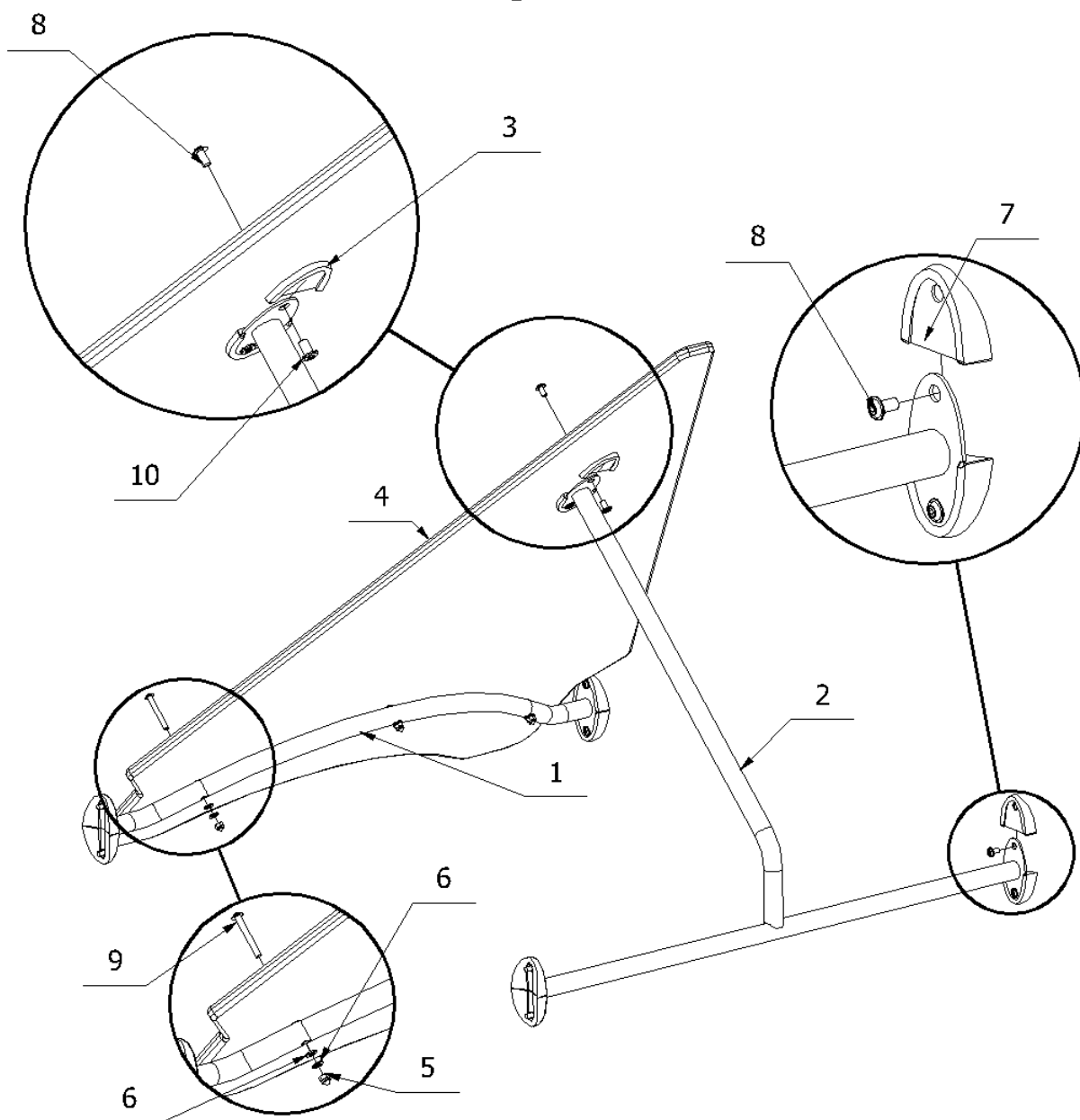

10	8902_002_A2	2
9	ISO7380_2_M8x65_A2	3
8	ISO7380_2_M8x16_A2	10
7	8919_001	8
6	ISO7089_8_A2	6
5	DIN986_M8_A2	3
4	E_2522_002	1
3	8919_002	2
2	L2522_002	1
1	L2522_001	1
Nr.	Nr Rys./Normy	Ilość

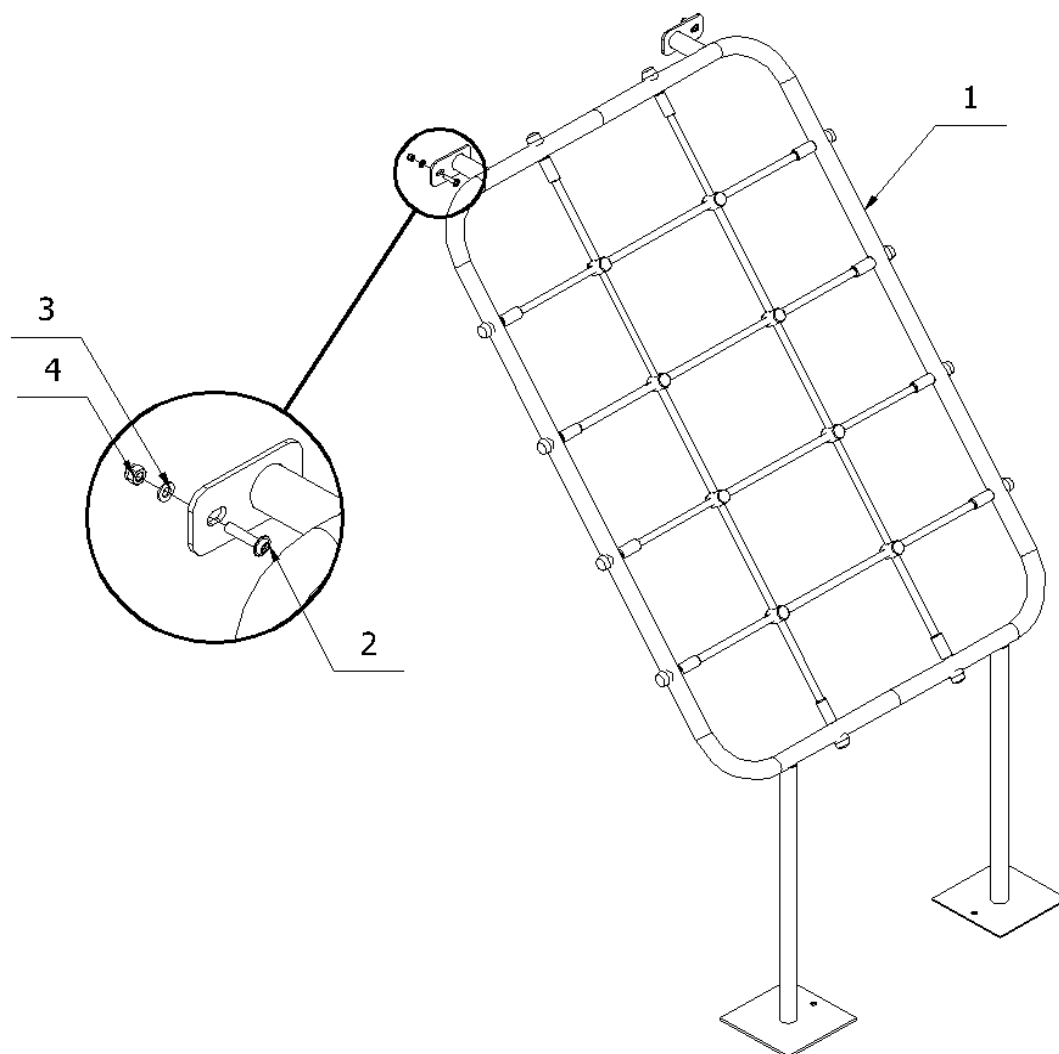
23238N

4	DIN986_M8_A2	2
3	ISO7089_8_A2	2
2	ISO7380_2_M8x35_A2	2
1	23238	1
Nr.	Nr Rys./Normy	Ilość

2476N / 2467N / 2468N / 2469N / 2470N / 2480N / 2481N

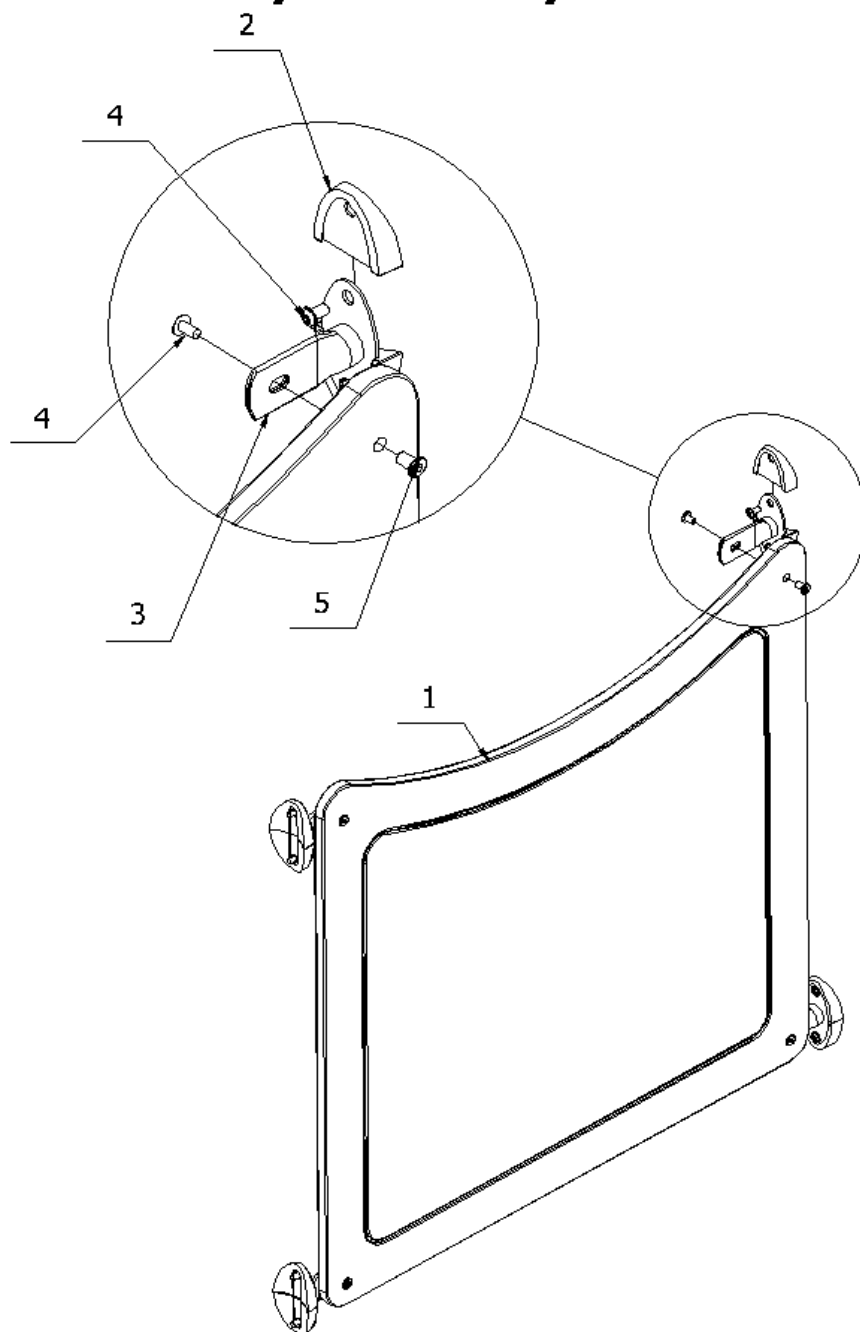

5	8902_002_A2	4
4	ISO7380 2 M8x16 A2	12
3	L8801_007	4
2	8919_001	8
1	E_2467_001	1
Nr.	Nr Rys./Normy	Ilość

23215N

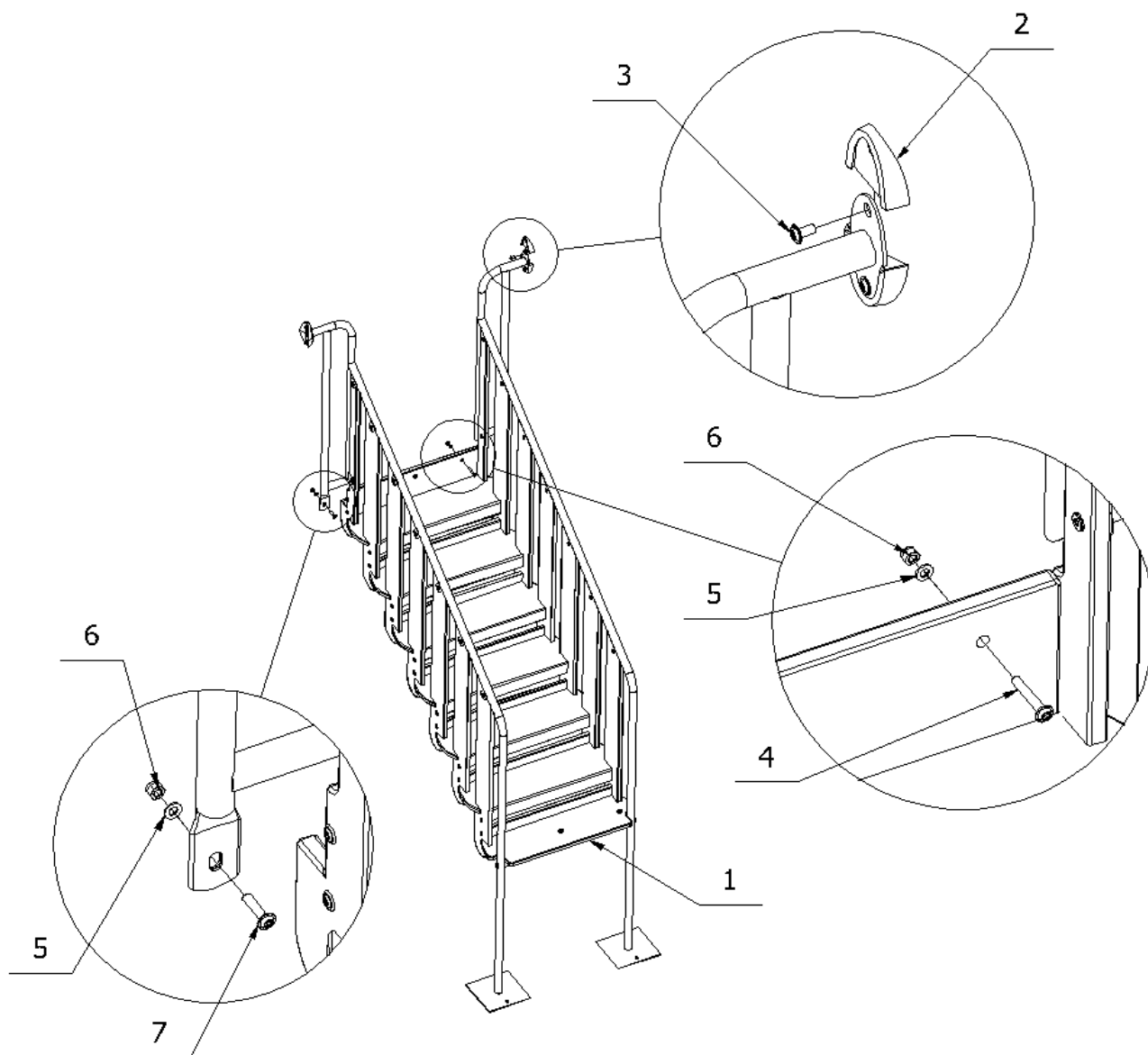

7	ISO7380_2_M8x35_A2	2
6	DIN986_M8_A2	5
5	ISO7089_8_A2	5
4	ISO7380_2_M8x50_A2	3
3	ISO7380_2_M8x16_A2	20
2	8919_001	4
1	23215	1
Nr.	Nr Rys./Normy	Ilość

2165N

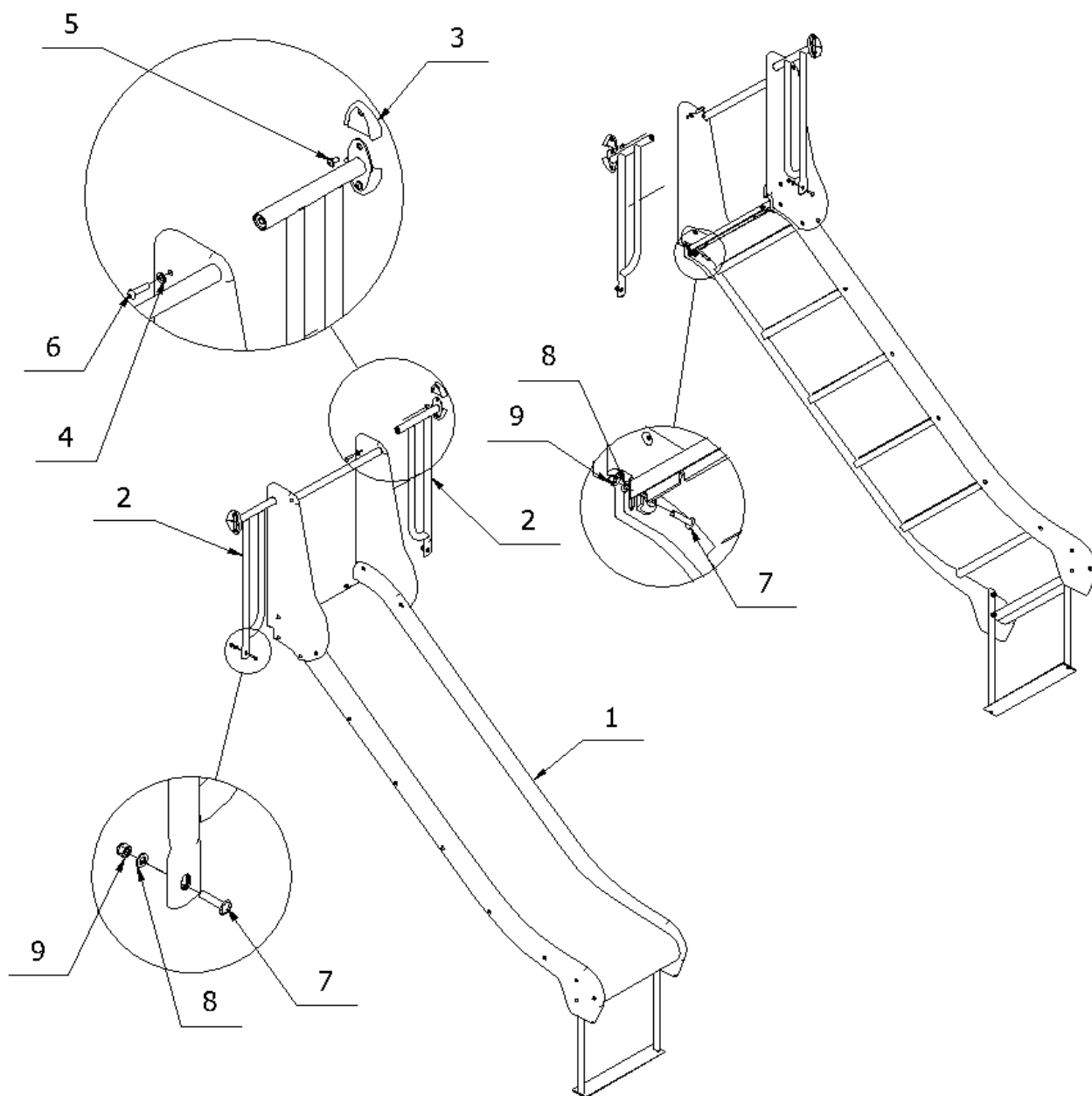

9	DIN986_M8_A2	4
8	ISO7089_8_A2	4
7	ISO7380_2_M8x35_A2	4
6	ISO7380_M10x40_A2	6
5	ISO7380_2_M8x16_A2	4
4	ISO7089_10_A2	2
3	8919_001	4
2	23170	2
1	2165	1
Nr.	Nr Rys./Normy	Ilość

23220N

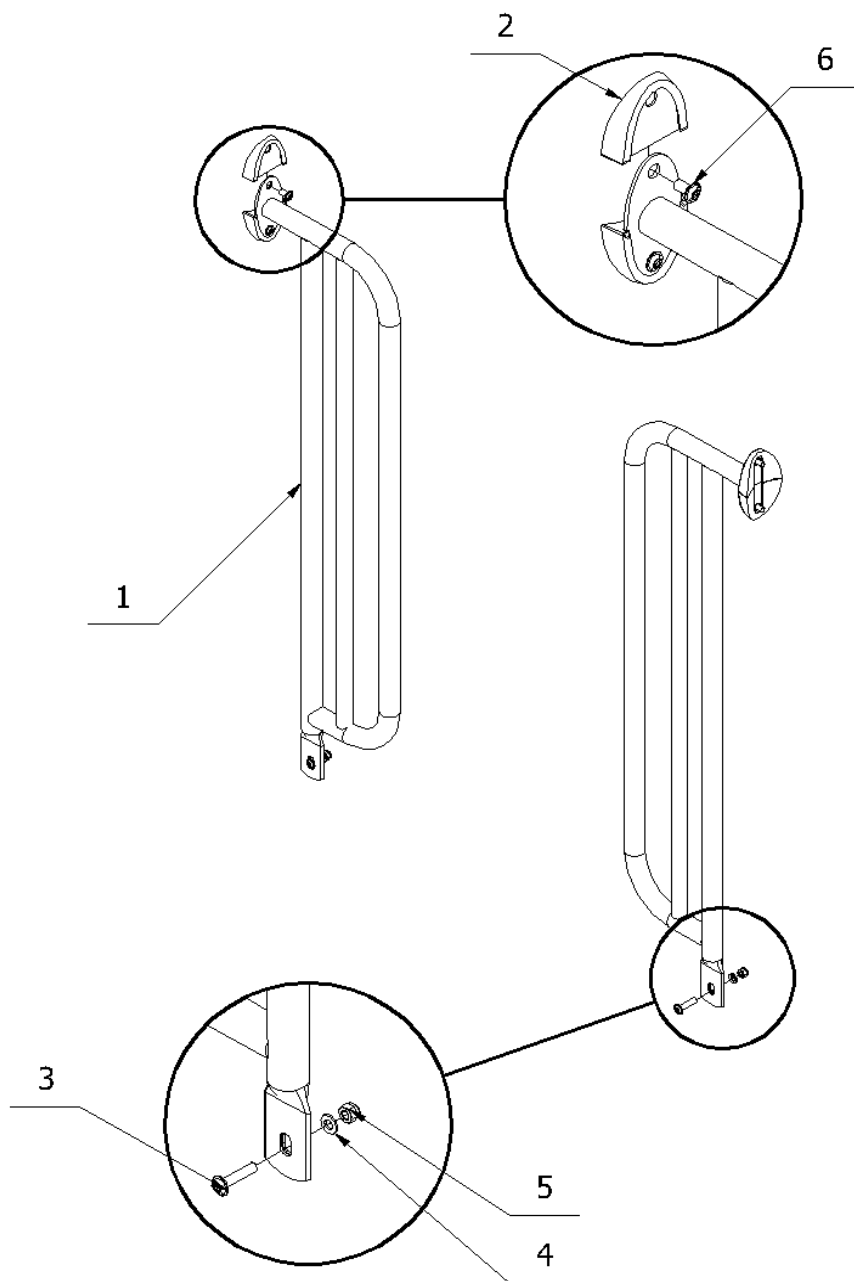

6	ISO7380_2_M8x16_A2	4
5	DIN986_M8_A2	2
4	ISO7089_8_A2	2
3	ISO7380_2_M8x35_A2	2
2	8919_001	4
1	L23220_002	2
Nr.	Nr Rys./Normy	Ilość