

PL	INSTRUKCJA MONTAŻU	Nazwa	Action4Kids MKP-J8018	Nr kat.	1933
ENG	ASSEMBLY INSTRUCTIONS	Product	Action4Kids MKP-J8018	Cat. no.	
DEU	MONTAGEANLEITUNG	Name	Action4Kids MKP-J8018	Art.-Nr.	
FRA	INSTRUCTIONS D'INSTALLATION	Catégorie	Action4Kids MKP-J8018	Référence.	

1933

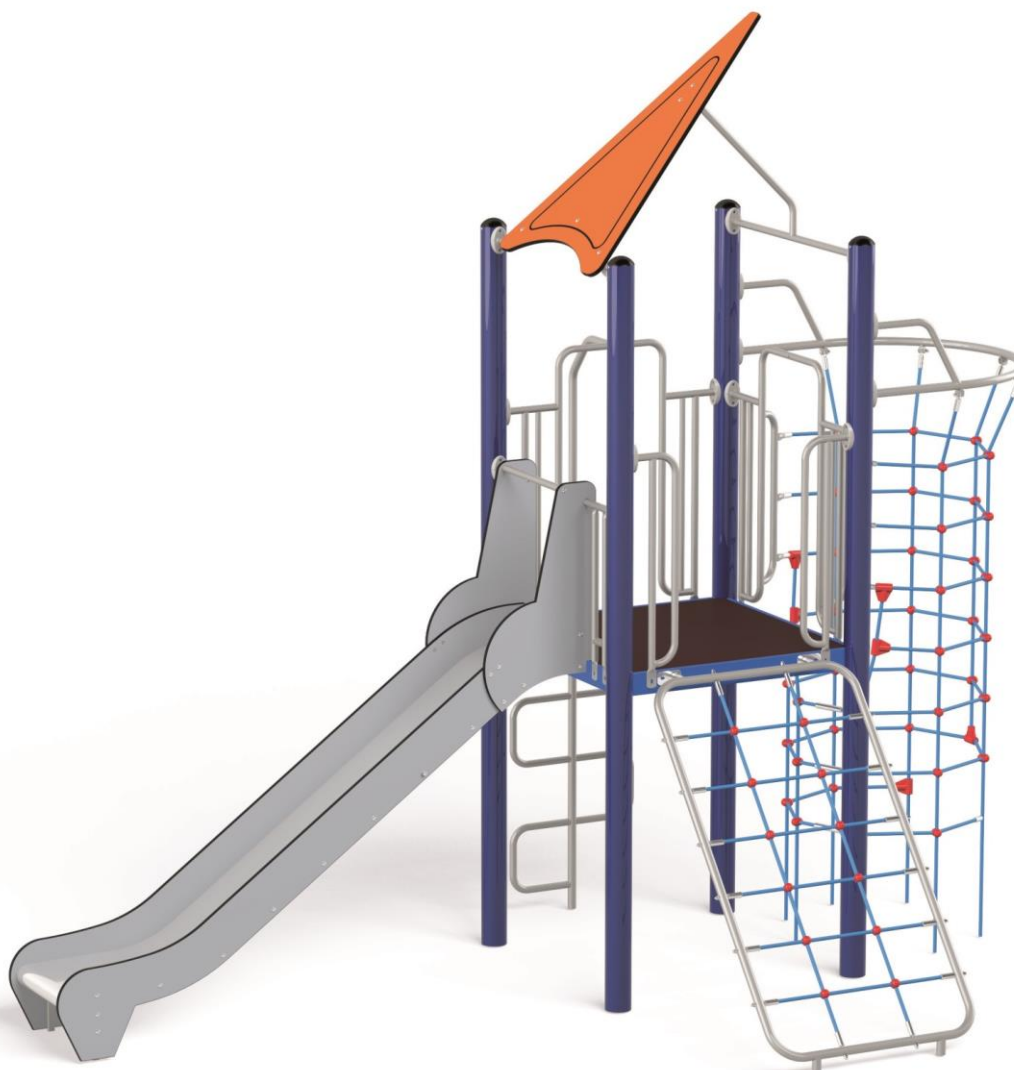

Wiek użytkowników Age of users Altersgruppe	Ilość użytkowników Number of users Anzahl der Benutzer Nombre d'utilisateurs	Przeznaczenie urządzenia Purpose of device Bestimmung des Spielgerätes	Zgodność z normą In accordance with the standard Geltende Norm
3-14	9	do zabawy na zewnątrz for outdoor playing zum draußen Spielen	PN-EN 1176-1:2017
NOVUM Sp. z o.o. Sp. k. ul. Bolesława Chrobrego 1, 12-100 Szczytno		e-mail: biuro@novumedukacja.pl	www.novumedukacja.pl
NOVUM Sp. z o.o. Sp. k. ul. Bolesława Chrobrego 1, 12-100 Szczytno		e-mail: eksport@novumgrom.com	www.novum4kids.com
NOVUM Deutschland GmbH, Schiffgesweg 11, 50259 Pulheim		e-mail: service@novum4kids.de	www.novum4kids.de
NOVUM DIRECT France Centre Commerciale La Samiane 01290 CROTTET		e-mail: contact@novum-direct.fr	www.novum-direct.fr

UWAGA / WARNING / ACHTUNG / ATTENTION:

PL Jeżeli w zestawie występuje zjeżdżalnia, zestaw należy posadować w taki sposób, aby ślizg zjeżdżalni znajdował się od strony północnej, czyli od strony nienasłonecznionej, aby zapobiegać nadmiernemu nagrzewaniu się ślizgu.

ENG If there is a slide in the set, it should be installed from the north, poorly sunny side to avoid possible hazards (burns) through direct skin contact.

DEU Wenn eine Spielplatzanlage eine Rutsche enthält, sollte diese Anlage so platziert werden, dass die Rutsche sich auf der Nordseite befindet, dh. auf der schattigen Seite, um übermäßige Erwärmung der Rutschbahn zu vermeiden.

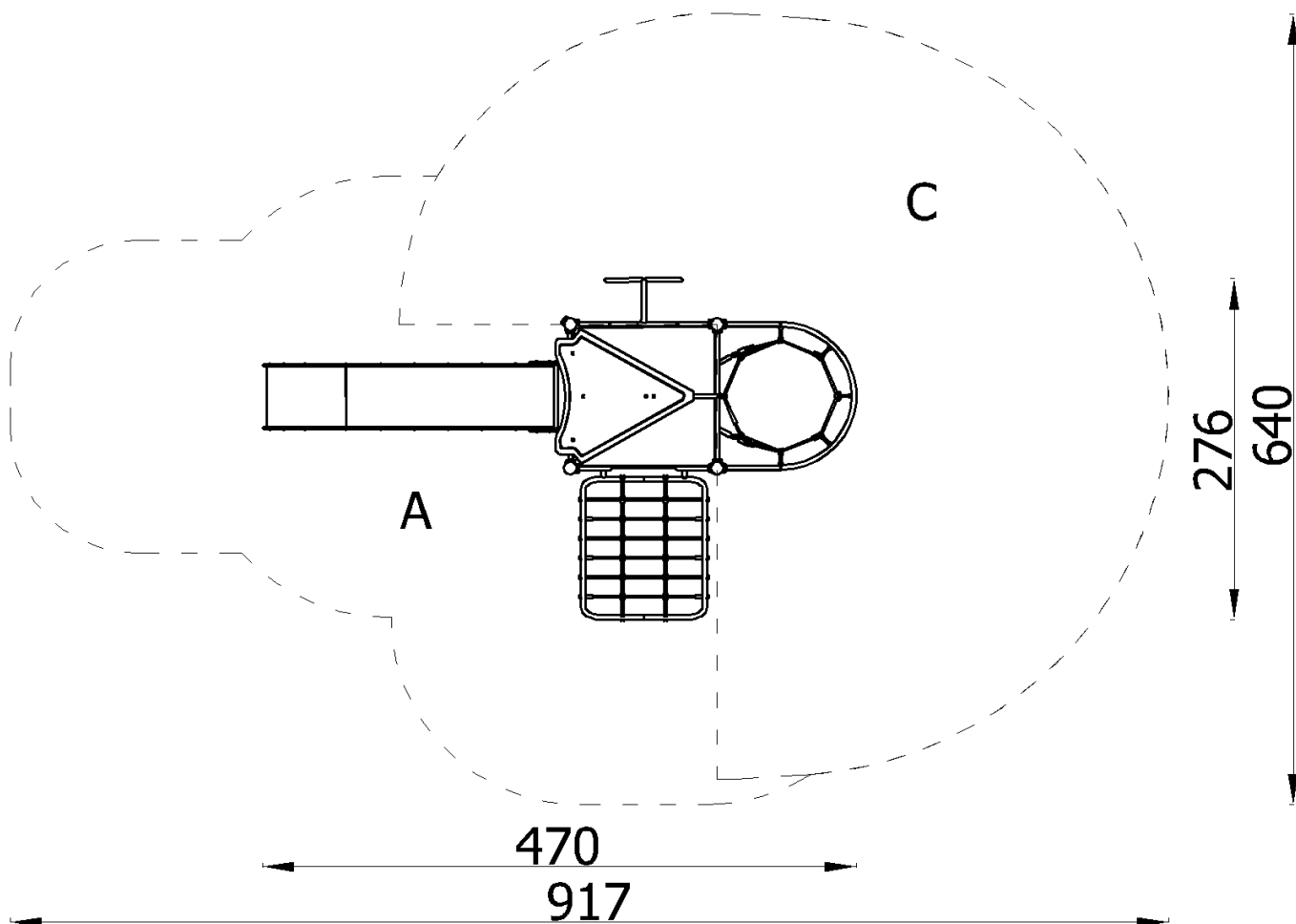

Montaż zgodnie z planem zagospodarowania terenu.
 Installation in accordance with the land development plan.
 Montage gemäß dem Flächennutzungsplan

Bezpieczna nawierzchnia / Safe surface / Safe Oberfläche / Surface sûre

Strefa Zone Zone Zone	Max. wysokość upadku Max. fall height Max. Fallhöhe Max. hauteur de chute	Pole powierzchni Surface area Fläche Surface	Obwód strefy bezpiecz. Perimeter security zone Umkreis der Fallschutzfläche Zone de périmètre de sé.
A	1,50 m	17,90 m ²	25,30 m
B	-	-	
C	2,95 m	22,90 m ²	

Nawierzchnia / Safe surface / Fallschutzbelag / fr			1933
	Materiał Material Material	Min. wysokość warstwy Min. layer thicknesses Min. Schichtöhe	
h<0,6 m	Beton / Concrete / Beton Nawierzchnia bitumiczna / Bituminous surfacing / Bituminöse Oberfläche		
h<1 m	Gleba / Topsoil / Boden Darı / Turf / Grasnarbe		
h<2 m	Kora / Bark / Borke	20÷80 mm	300
	Wióry / Wood chips / Holzhacksnitzel	5÷30 mm	
	Piasek / Sand / Sand Żwir / Gravel / Kies	0,25÷8 mm	
h<3 m	Kora / Bark / Borke	20÷80 mm	400
	Wióry / Wood chips / Holzhacksnitzel	5÷30 mm	
	Piasek / Sand / Sand Żwir / Gravel / Kies	0,25÷8 mm	
h<3 m	Nawierzchnia syntetyczna / Synthetic granulates / Synthetische Oberfläche	wg danych producenta acc. to the manufacturer's data nach Angaben des Herstellers	

Posadowienie / Foundation / Gründung / Fondation	1933
--	------

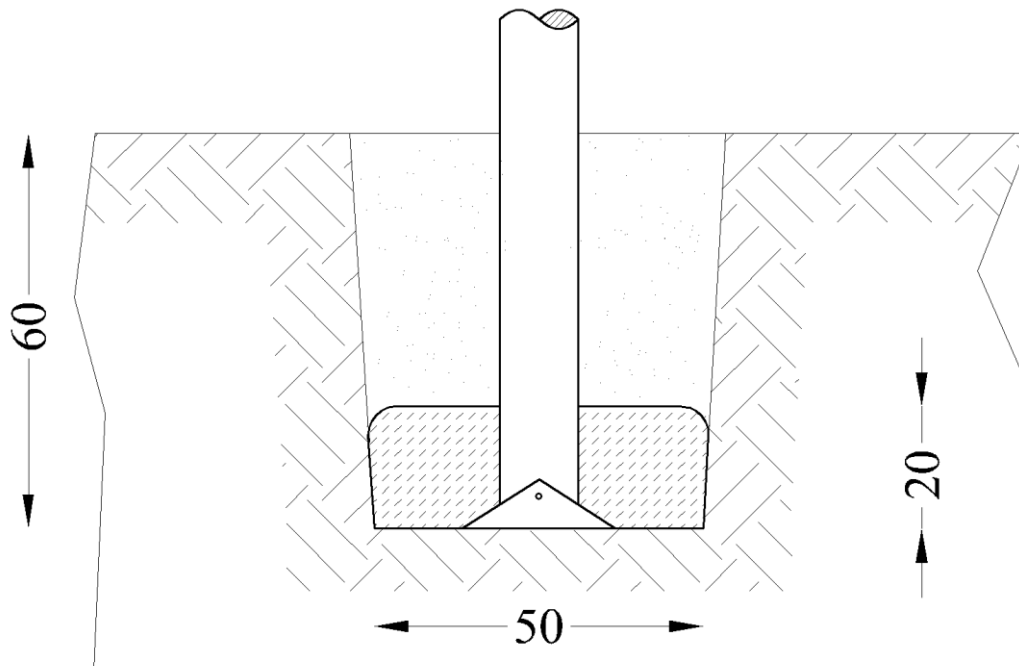

Beton / Concrete / Beton: **C16/20** - **0,55 m³**

W celu kontroli fundamentów należy usunąć nawierzchnię bezpieczną / piasek / żwir etc.
 In order to control the foundations, remove the safe surface (sand, gravel, etc.)
 Um die Fundamente zu überprüfen, entfernen Sie den Fallschutzbelag: Sand/ Kies etc.

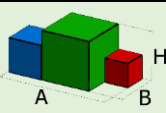
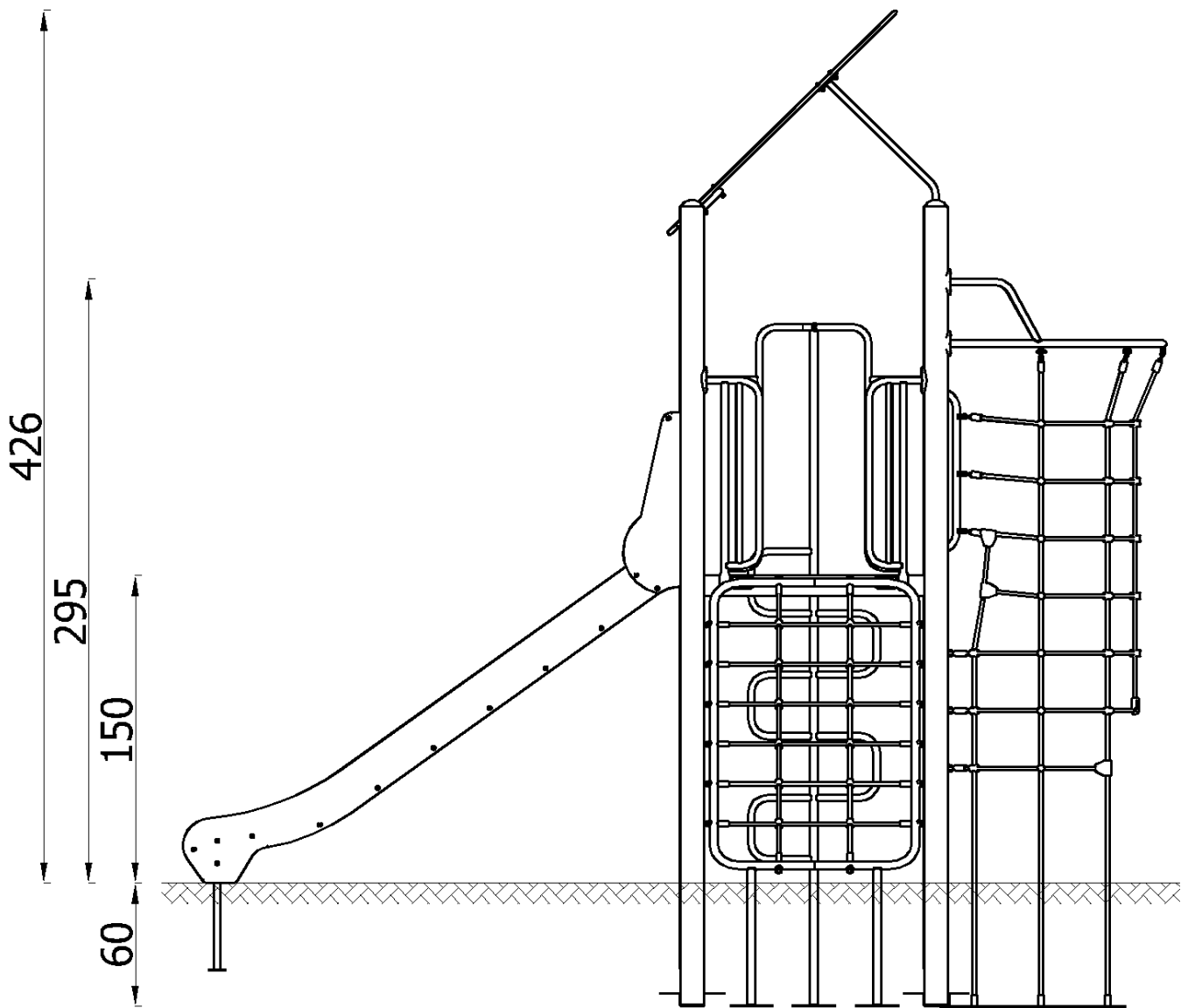

9,17x6,4x4,7
(AxBxH) [m]

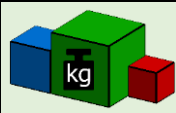

241 kg

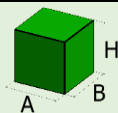

0,11x0,11x3,94
(AxBxH) [m]



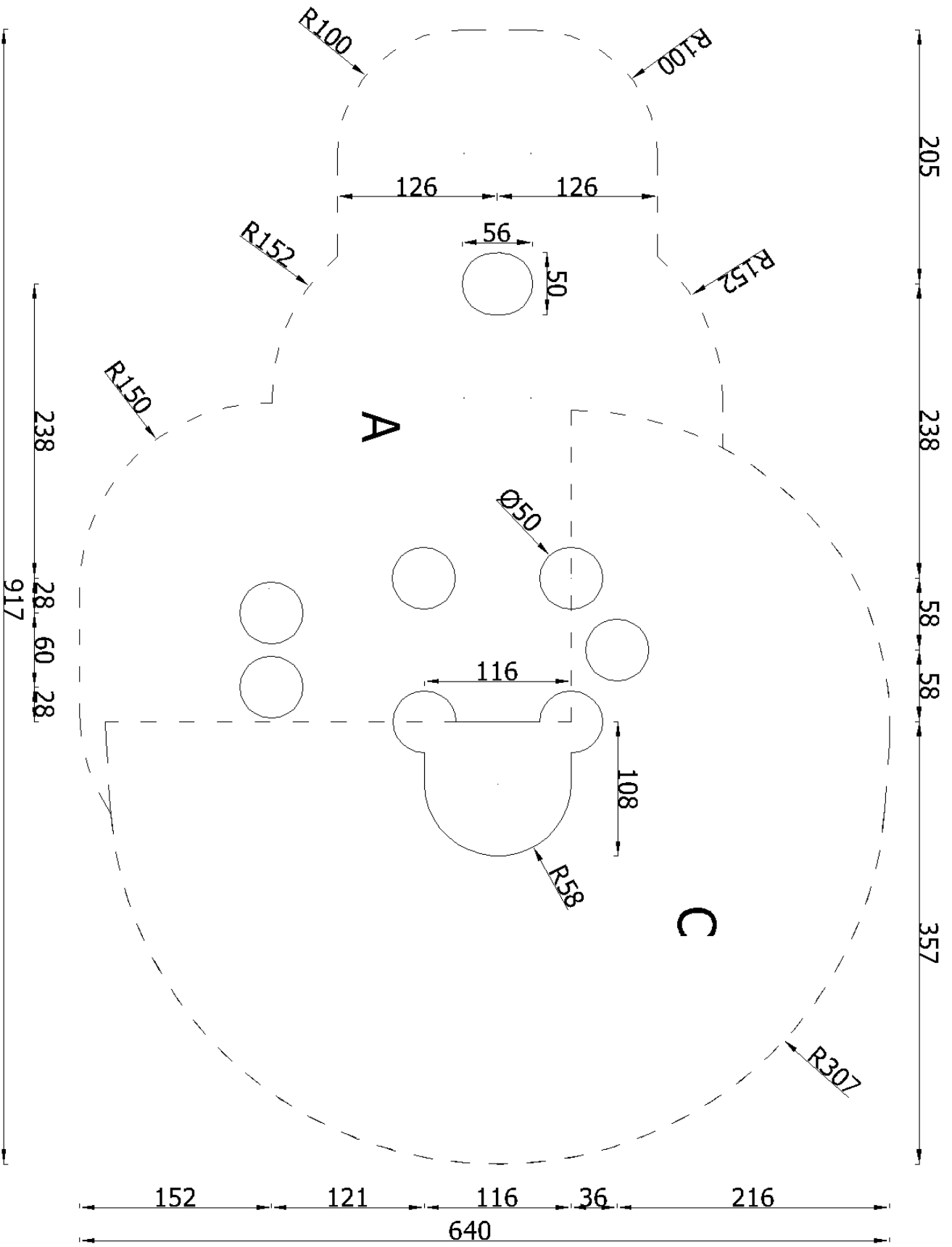

74 kg

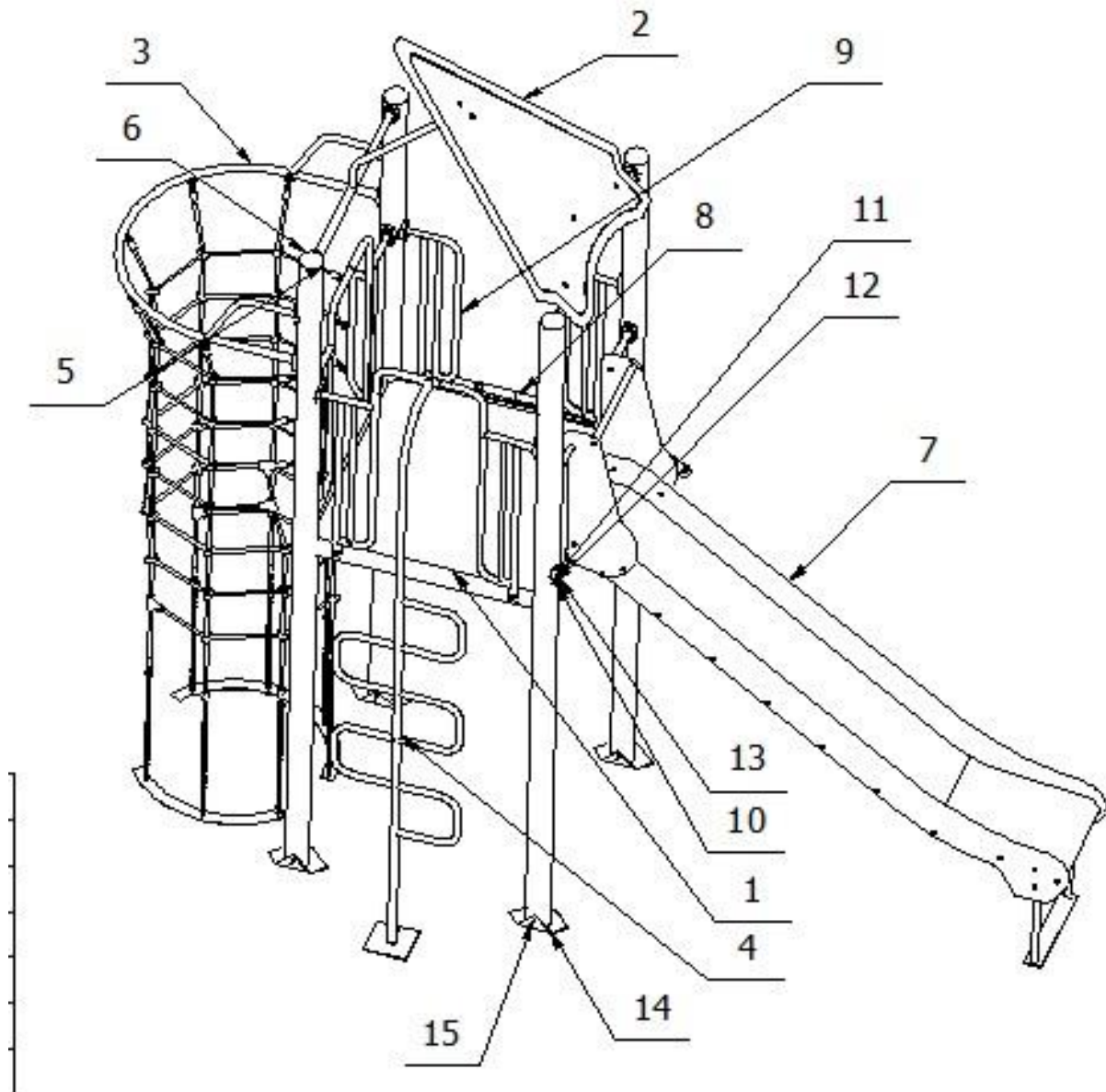



Części zamienne dostępne u producenta. Stosować klej do gwintów w połączeniach śrubowych.
Spare parts available from the manufacturer. Use thread glue in screw connections.
Ersatzteile beim Hersteller erhältlich. Gewindekleber für Schraubverbindungen verwenden.

15	Zestaw słupów wierconych	1933/1 - 1933/4	1				
14	Zaślepka okrągła płaska rury 114,3	8912_019	4				
13	Tabliczka znamionowa pionowa	8918_002	1				
12	Śruba z łbem kulistym Pin torx	ISO7380_M10x25_PT_A2	2				
11	Podkładka	ISO7089_10_A2	2				
10	Wkładka łezka wklęsła	8919_001	2				
9	Wejściówka niższa A4K	23220	1				
8	Wejście linowe 150 A4K	23247	1				
7	Zjeżdżalnia 150 A4K	2166	1				
6	Zaślepka kołpakowa rury 114,3	8912_120	4				
5	Nit zrywalny	DIN7337_A5x10	8				
4	Drabinka strażacka 150 A4K	23307	1				
3	Tunel linowy - pionowy	23172	1				
2	Dach jednospadowy A4K	2522	1				
1	Podest kwadratowy A4K	20104	1				
Lp. Art. Nr.	No. Rep.	Nazwa części Teilename	Part name Nom de la pièce	Nr części Teile-Nr	Part No. Partie No.	Ilość Anzahl	Quantity Nombre

															
								5 m	30 m						
															
2,5 m				60 cm	100 cm										
															
				7 mm								13 mm	17 mm	19 mm	24 mm
															
13 mm	17 mm	19 mm	24 mm	4 mm	5 mm	6 mm	8 mm	T40				T45			
															

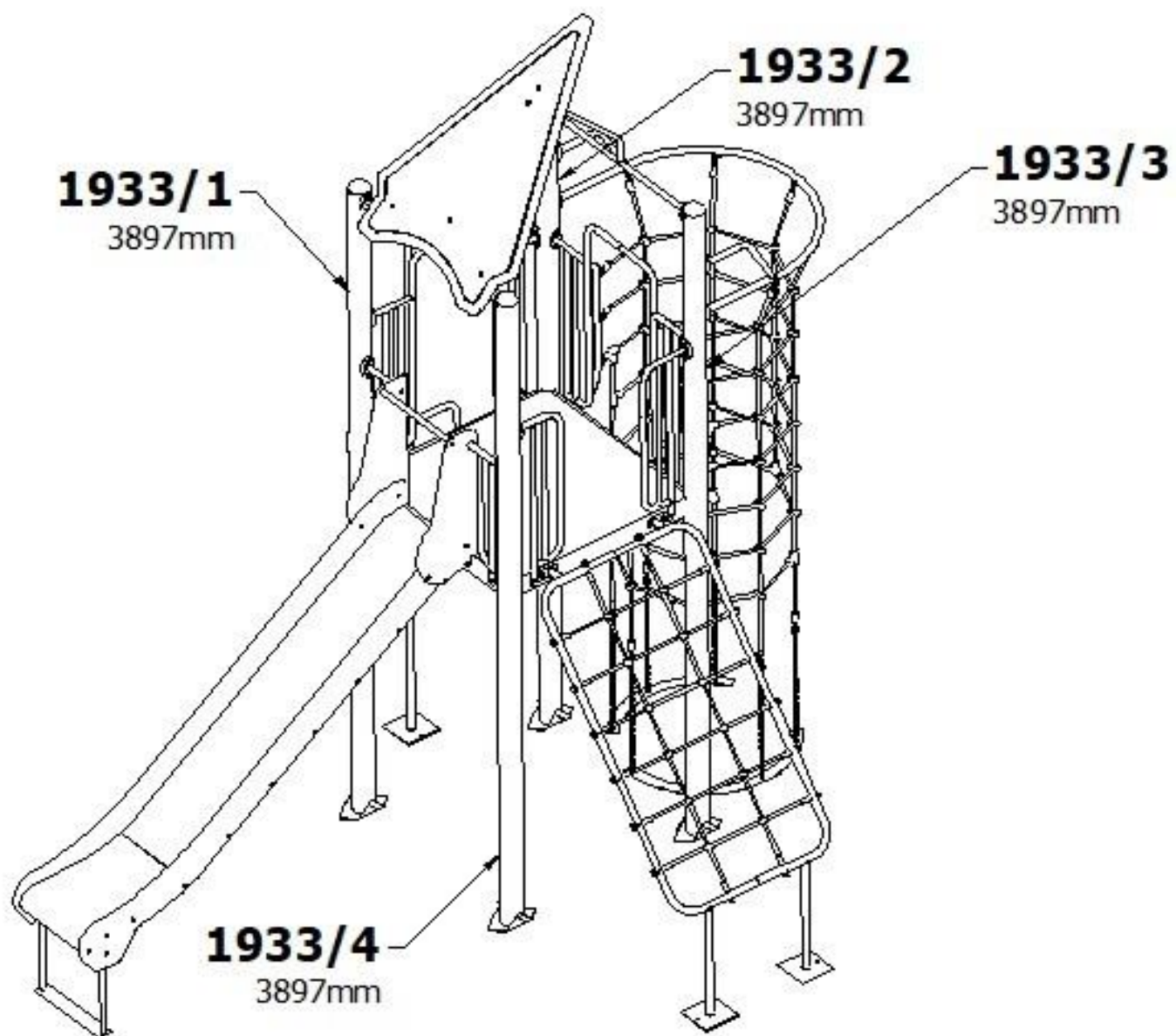

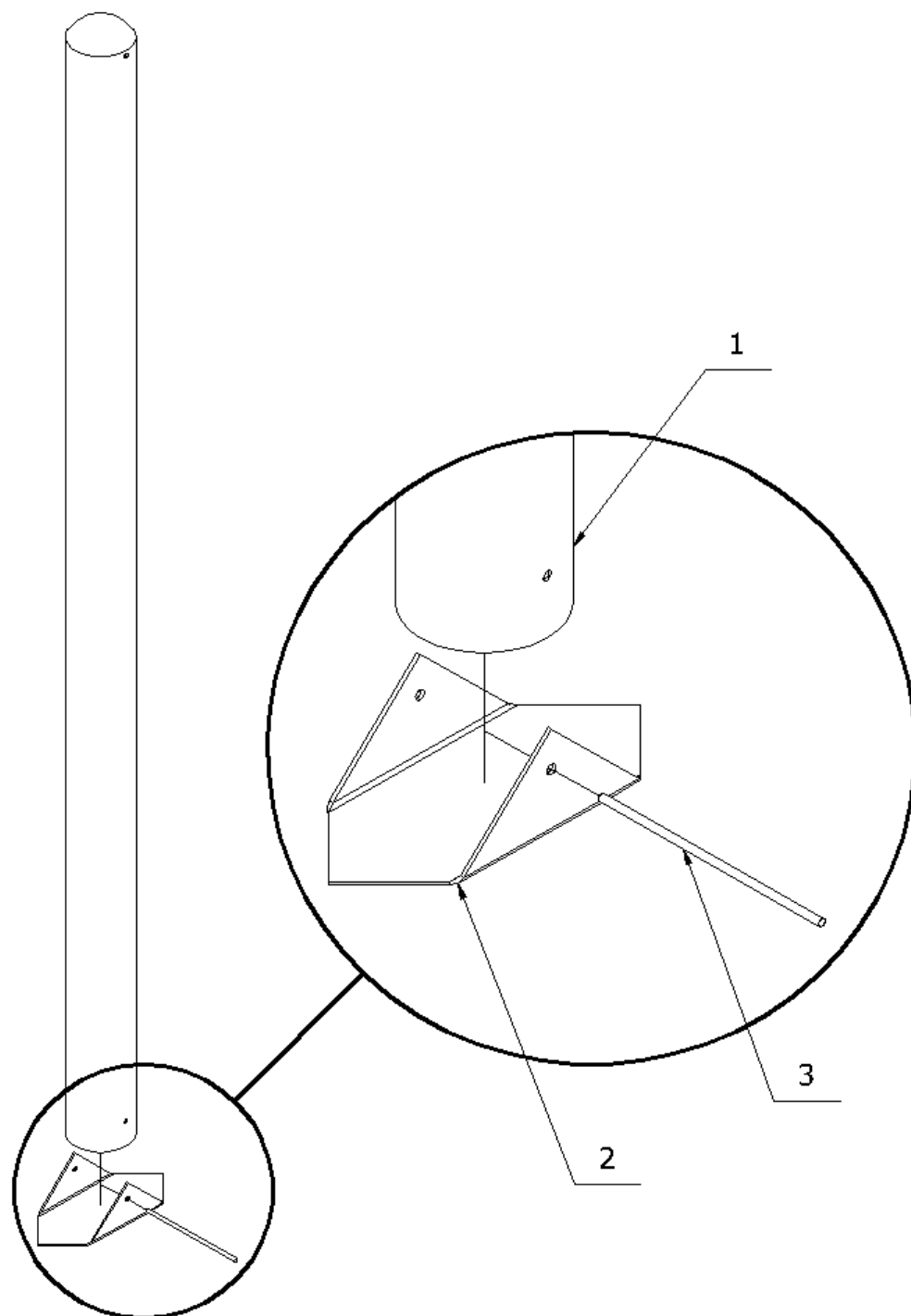
SŁUP / POLE

3	8850_002	1
2	B_8802_025	1
1	SŁUP/ POLE	1
Nr.	Nr Rys./Normy	Ilość

20104

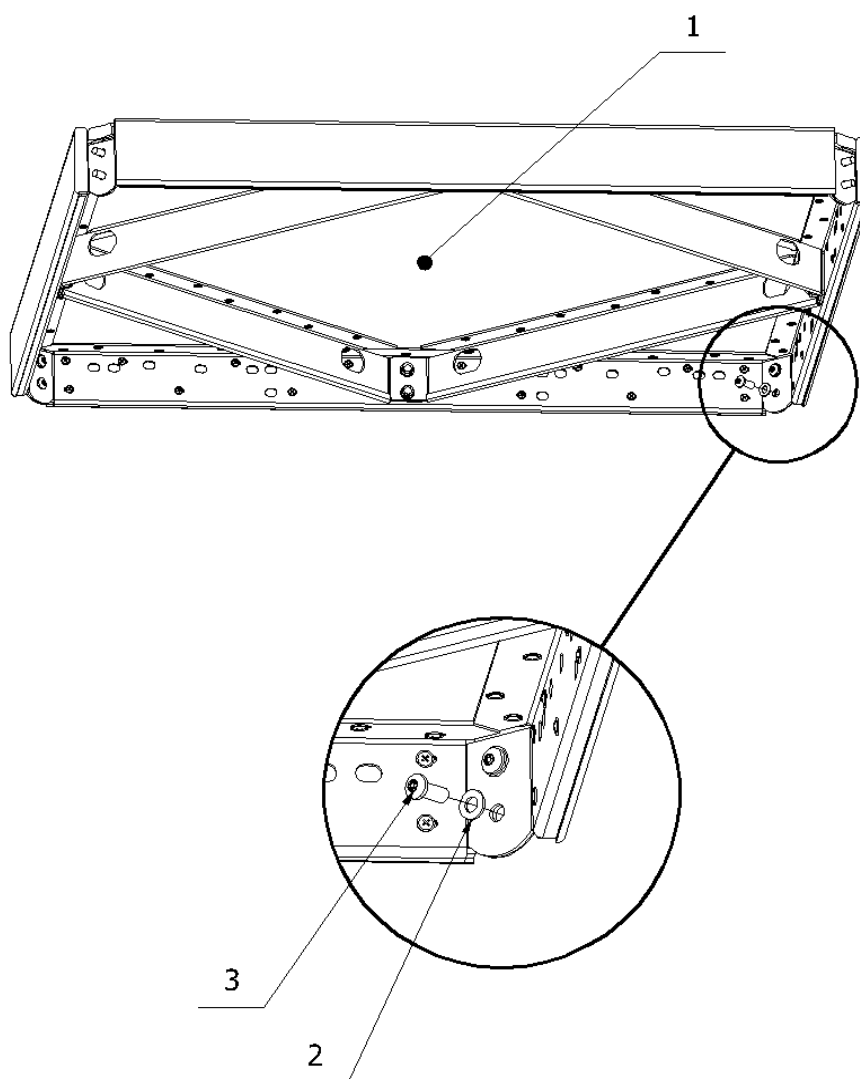

3	ISO7380_M10x25_PT_A2	8
2	ISO7089_10_A2	8
1	20104	1
Nr.	Nr Rys./Normy	Ilość

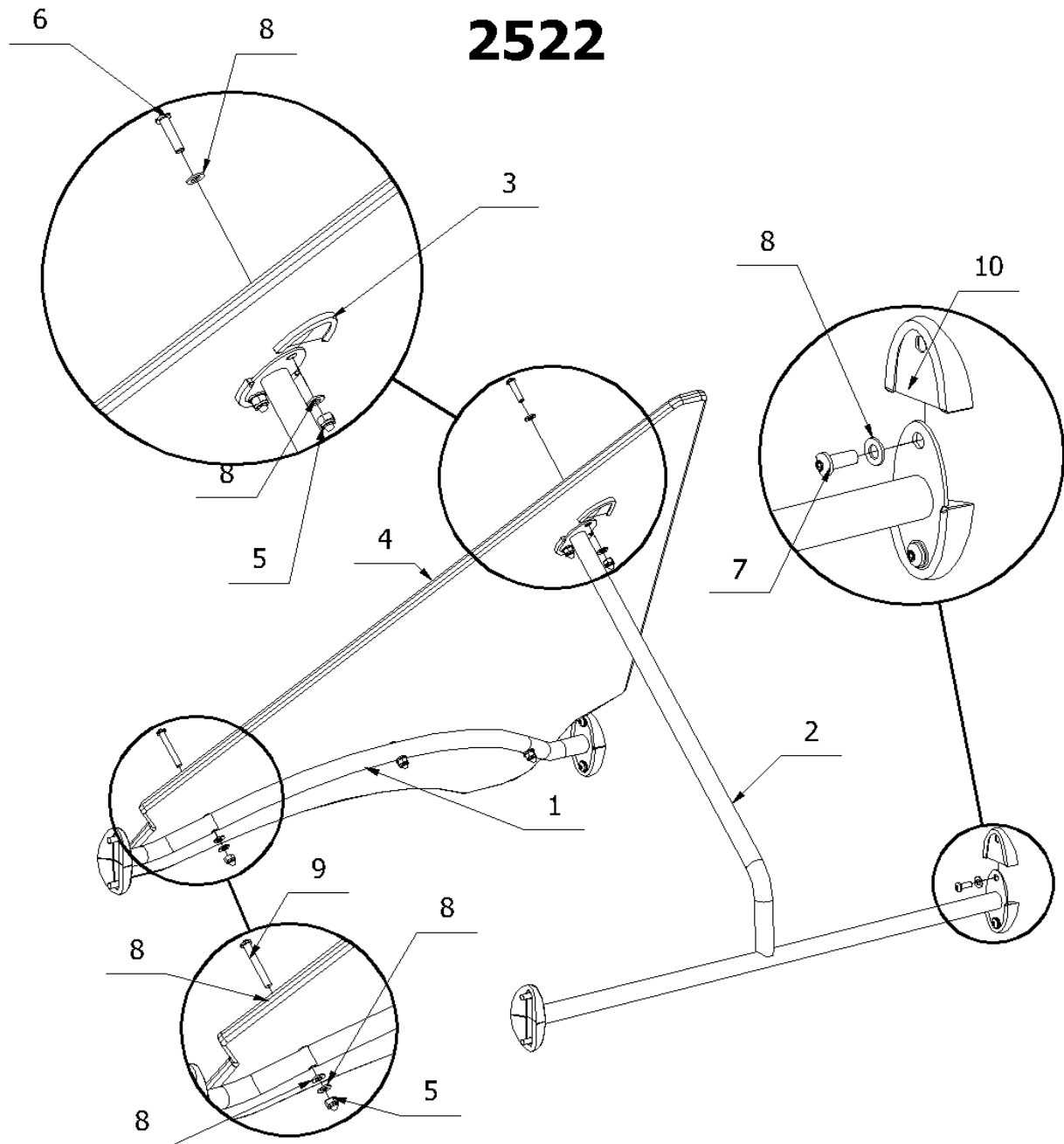

10	8919_001	8
9	ISO7380_M10x70_PT_A2	3
8	ISO7089_10_A2	21
7	ISO7380_M10x25_PT_A2	8
6	ISO7380_M10x40_PT_A2	2
5	DIN986_M10_A2	5
4	E_2522_002	1
3	8919_002	2
2	L2522_002	1
1	L2522_001	1
Nr.	Nr Rys./Normy	Ilość

23172

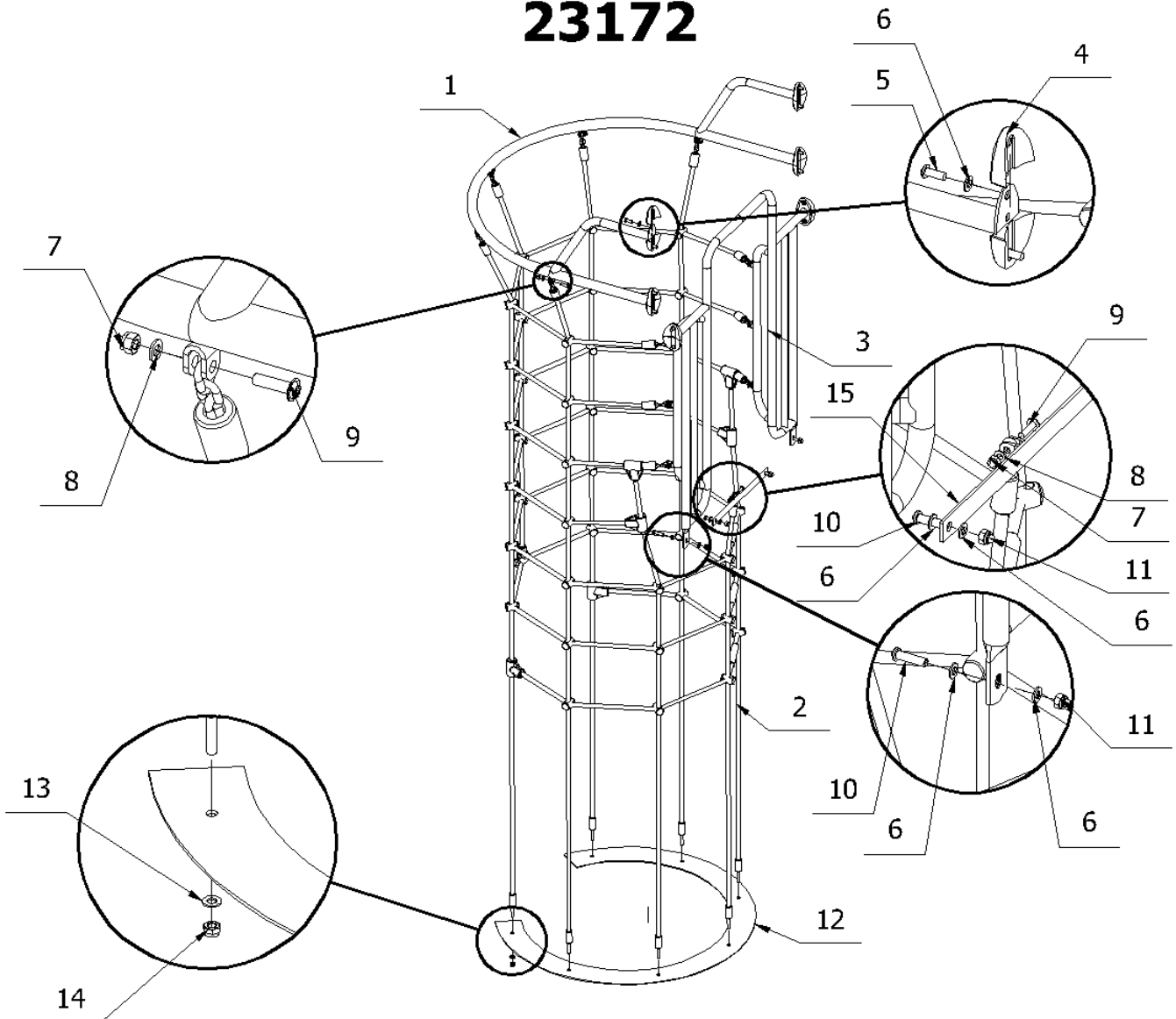

15	L23172_005	1
14	DIN985_M10	7
13	ISO7089_10	7
12	B_23172_001	1
11	DIN986_M10_A2	4
10	ISO7380_M10x40_PT_A2	4
9	ISO7380_2_M8x30_A2	12
8	ISO7089_8_A2	12
7	DIN986_M8_A2	12
6	ISO7089_10_A2	20
5	ISO7380_M10x25_PT_A2	12
4	8919_001	12
3	L23172_001	1
2	L23172_003	1
1	L23172_002	1
Nr.	Nr Rys./Normy	Ilość

23307

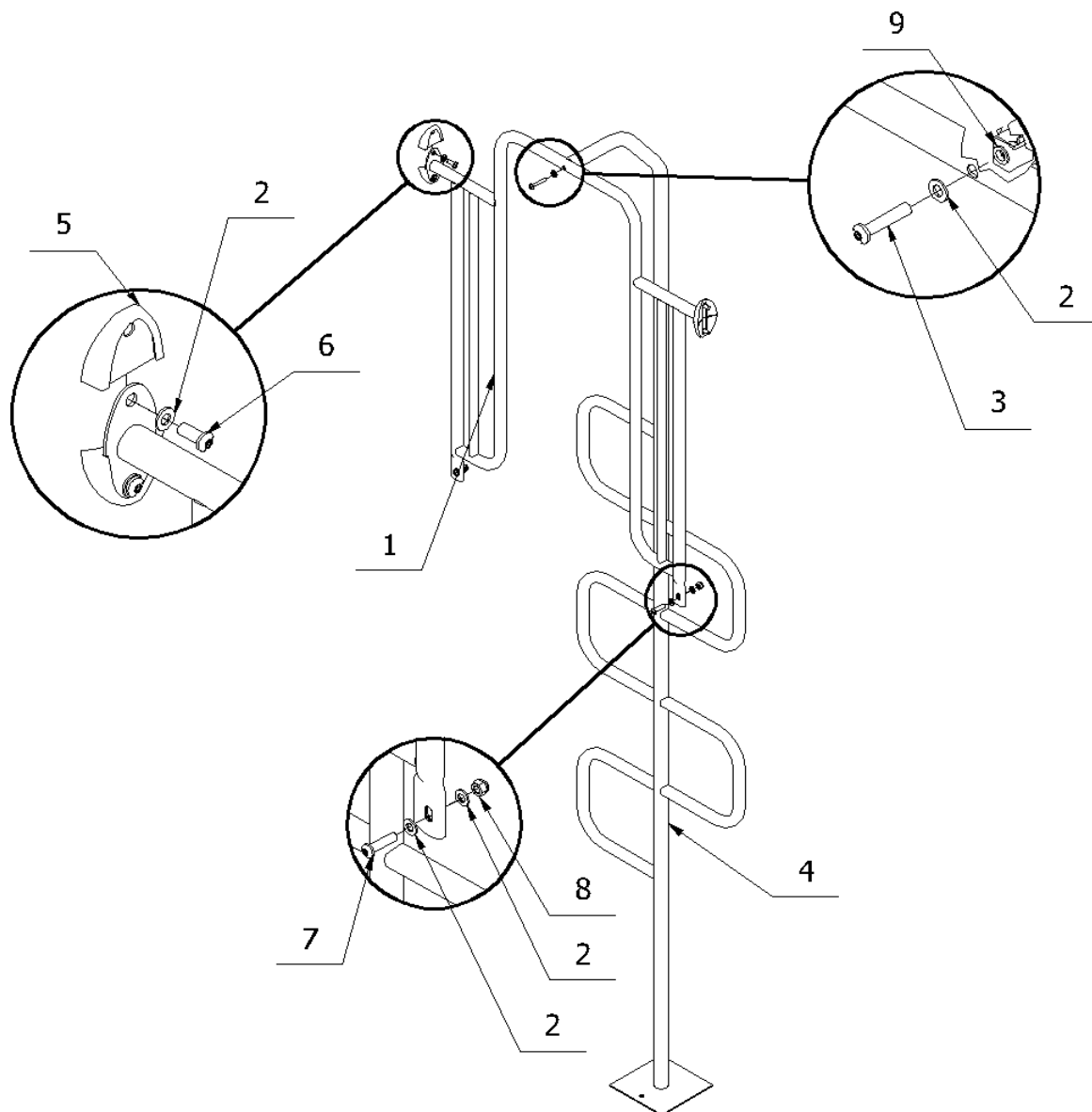

9	8902_103_A2	1
8	DIN986_M10_A2	2
7	ISO7380_M10x40_PT_A2	2
6	ISO7380_M10x25_PT_A2	4
5	8919_001	4
4	L23307_001	1
3	ISO7380_M10x50_PT_A2	1
2	ISO7089_10_A2	9
1	L23239_001	1
Nr.	Nr Rys./Normy	Ilość

2166

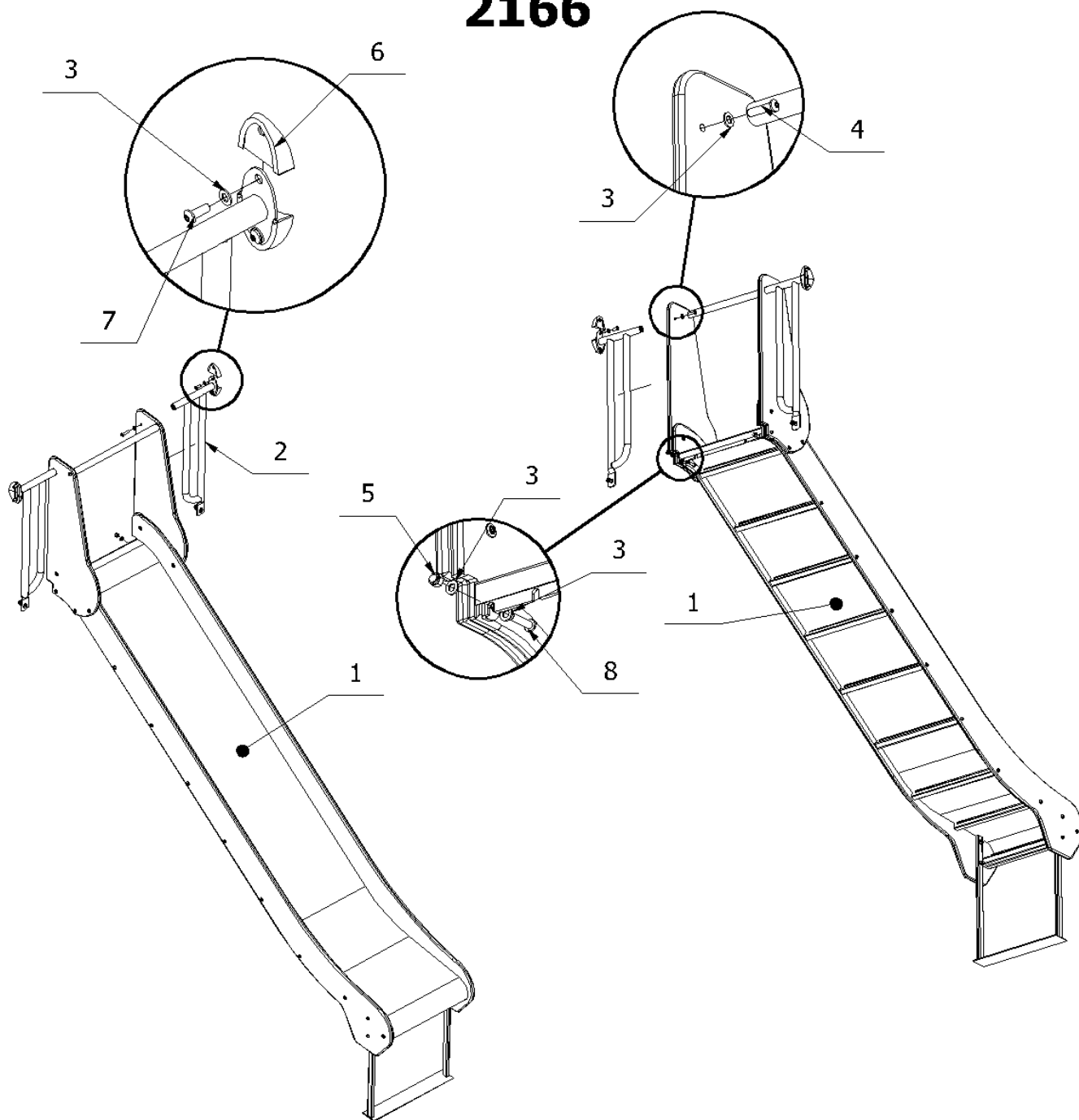

8	ISO7380_M10x45_PT_A2	2
7	ISO7380_M10x25_PT_A2	4
6	8919_001	4
5	DIN986_M10_A2	4
4	ISO7380_M10x40_PT_A2	4
3	ISO7089_10_A2	14
2	23170	2
1	2166	1
Nr.	Nr Rys./Normy	Ilość

23247

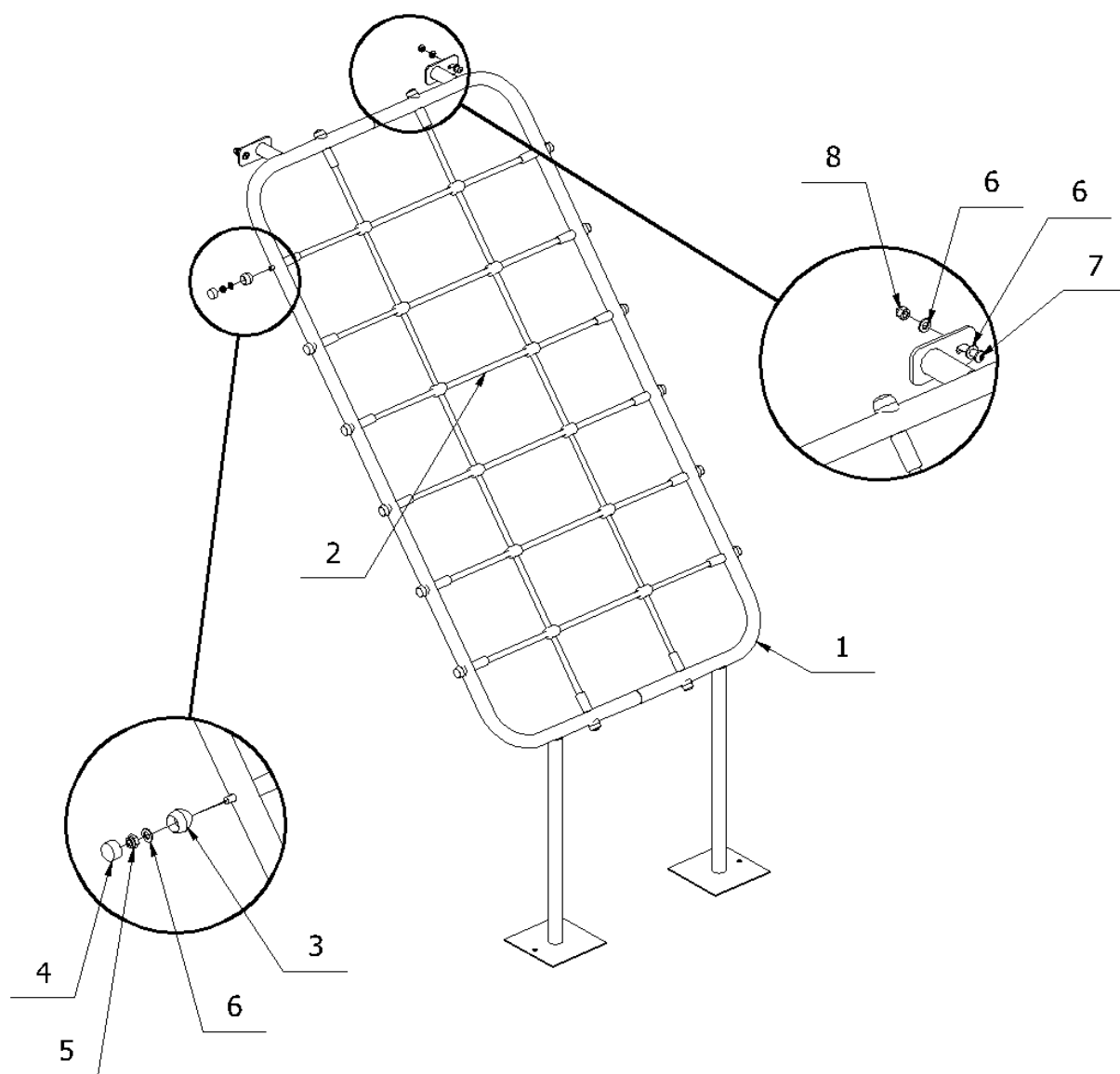

8	DIN986_M10_A2	2
7	ISO7380_M10x40_PT_A2	2
6	ISO7089_10_A2	20
5	DIN985_M10_A2	16
4	8924_103	16
3	8924_005	16
2	L23247_002	1
1	L23247_001	1
Nr.	Nr Rys./Normy	Ilość

23220

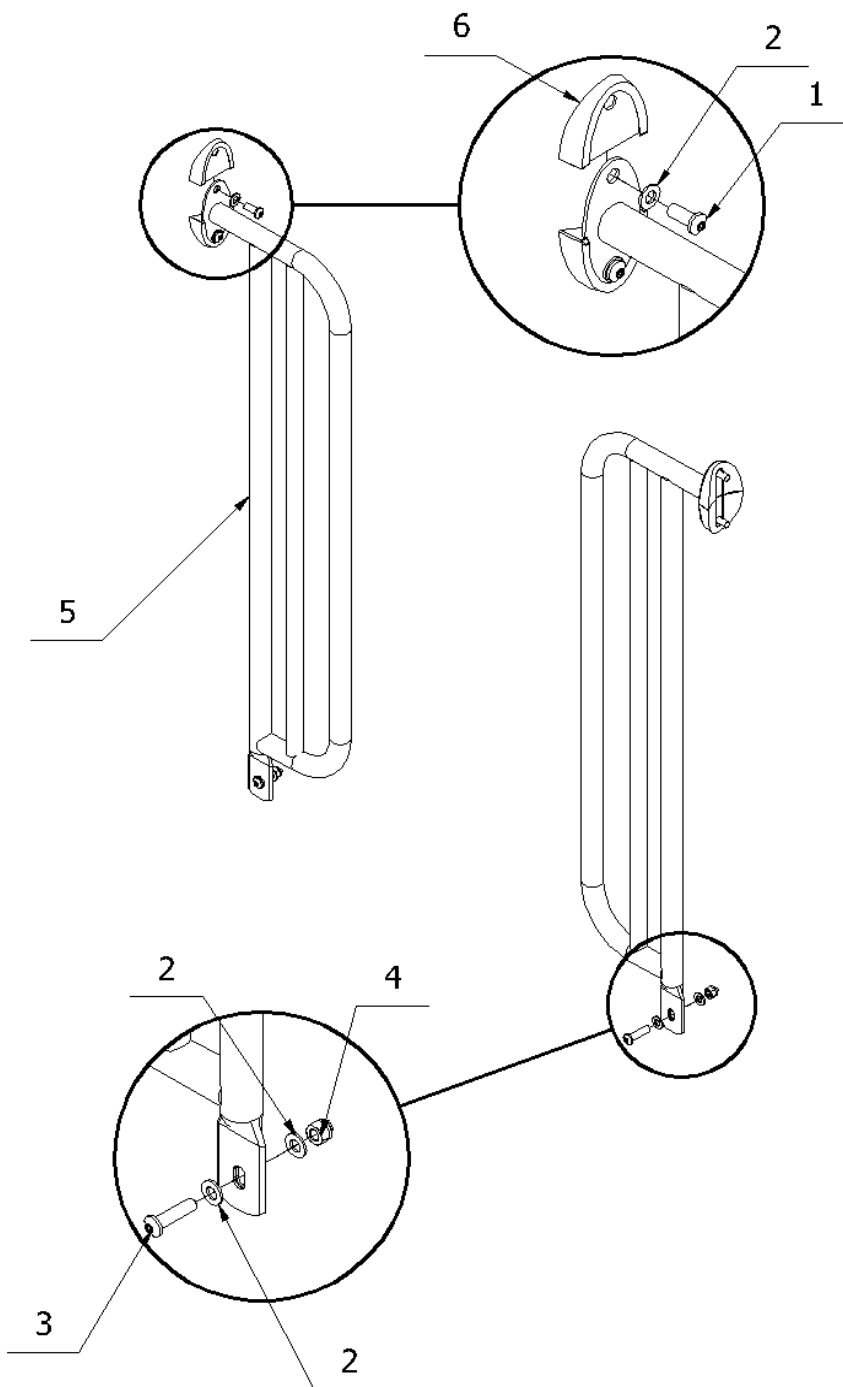

6	8919_001	4
5	L23220_001	2
4	DIN986_M10_A2	2
3	ISO7380_M10x40_PT_A2	2
2	ISO7089_10_A2	8
1	ISO7380_M10x25_PT_A2	4
Nr.	Nr Rys./Normy	Ilość