



PL	INSTRUKCJA MONTAŻU	Nazwa	Action4Kids MK-6040-006	Nr kat.	1938
ENG	ASSEMBLY INSTRUCTIONS	Product	Action4Kids MK-6040-006	Cat. no.	
DEU	MONTAGEANLEITUNG	Name	Action4Kids MK-6040-006	Art.-Nr.	
FRA	INSTRUCTIONS D'INSTALLATION	Catégorie	Action4Kids MK-6040-006	Référence.	

1938



Wiek użytkowników Age of users Altersgruppe	Ilość użytkowników Number of users Anzahl der Benutzer Nombre d'utilisateurs	Przeznaczenie urządzenia Purpose of device Bestimmung des Spielgerätes	Zgodność z normą In accordance with the standard Geltende Norm
3-14	15	do zabawy na zewnątrz for outdoor playing zum draußen Spielen	PN-EN 1176-1:2017
NOVUM Sp. z o.o. Sp. k. ul. Bolesława Chrobrego 1, 12-100 Szczytno		e-mail: biuro@novumedukacja.pl www.novumedukacja.pl	
NOVUM Sp. z o.o. Sp. k. ul. Bolesława Chrobrego 1, 12-100 Szczytno		e-mail: eksport@novumgrom.com www.novum4kids.com	
NOVUM Deutschland GmbH, Schiffgesweg 11, 50259 Pulheim		e-mail: service@novum4kids.de www.novum4kids.de	
NOVUM DIRECT France Centre Commerciale La Samiane 01290 CROTTET		e-mail: contact@novum-direct.fr www.novum-direct.fr	

UWAGA / WARNING / ACHTUNG / ATTENTION:

PL Jeżeli w zestawie występuje zjeżdżalnia, zestaw należy posadzić w taki sposób, aby ślizg zjeżdżałni znajdował się od strony północnej, czyli od strony nienasłonecznionej, aby zapobiegać nadmiernemu nagrzewaniu się ślizgu.

ENG If there is a slide in the set, it should be installed from the north, poorly sunny side to avoid possible hazards (burns) through direct skin contact.

DEU Wenn eine Spielplatzanlage eine Rutsche enthält, sollte diese Anlage so platziert werden, dass die Rutsche sich auf der Nordseite befindet, dh. auf der schattigen Seite, um übermäßige Erwärmung der Rutschbahn zu vermeiden.

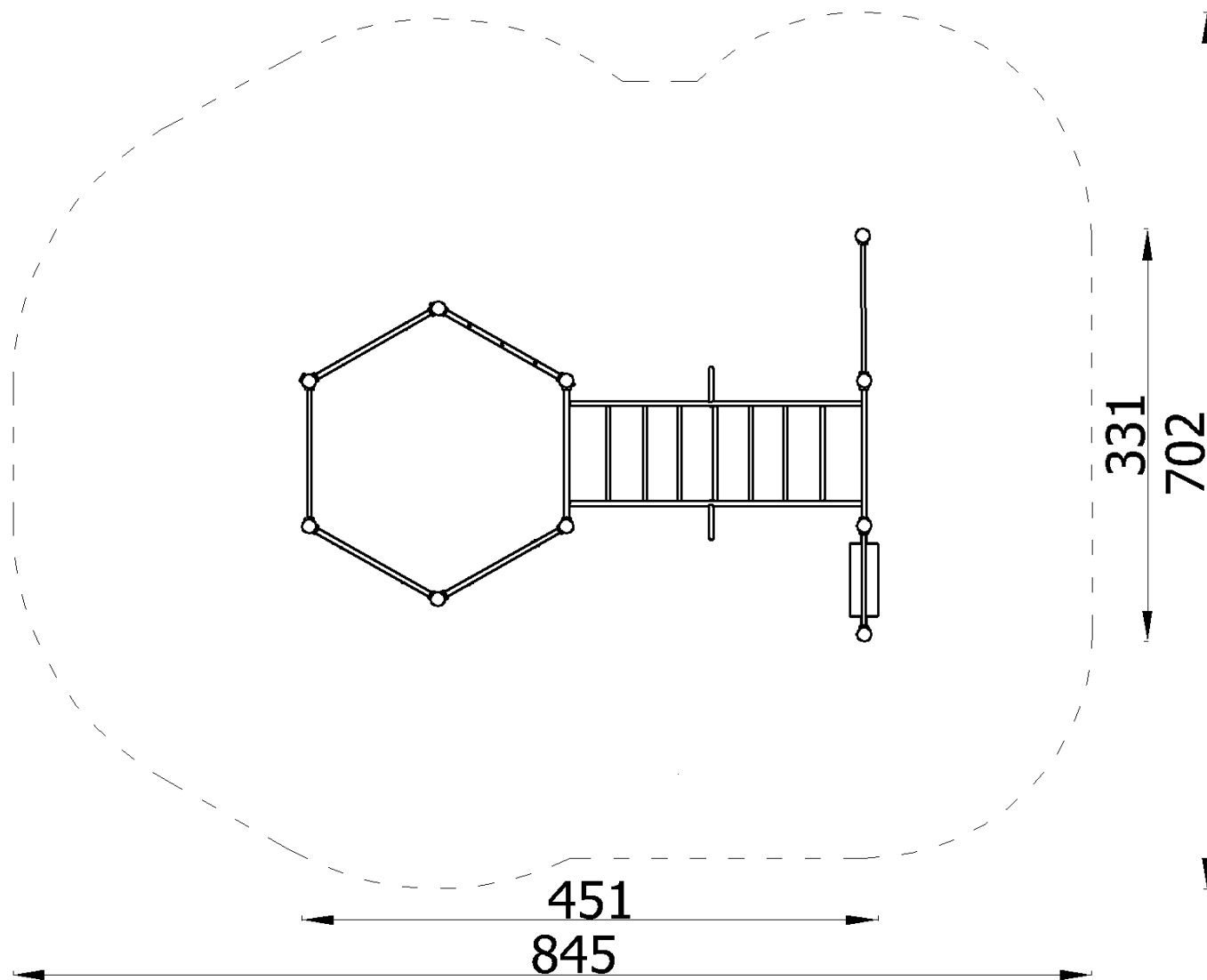

Montaż zgodnie z planem zagospodarowania terenu.
 Installation in accordance with the land development plan.
 Montage gemäß dem Flächennutzungsplan

Bezpieczna nawierzchnia / Safe surface / Safe Oberfläche / Surface sûre

Strefa Zone Zone Zone	Max. wysokość upadku Max. fall height Max. Fallhöhe Max. hauteur de chute	Pole powierzchni Surface area Fläche Surface	Obwód strefy bezpiecz. Perimeter security zone Umkreis der Fallschutzfläche Zone de périmètre de sé.
A	-	-	26,60 m
B	-	-	
C	2,64 m	51,00 m ²	

Nawierzchnia / Safe surface / Fallschutzbelag / fr			1938
	Materiał Material Material	Min. wysokość warstwy Min. layer thicknesses Min. Schichtöhe	
h<0,6 m	Beton / Concrete / Beton Nawierzchnia bitumiczna / Bituminous surfacing / Bituminöse Oberfläche		
h<1 m	Gleba / Topsoil / Boden Darń / Turf / Grasnarbe		
h<2 m	Kora / Bark / Borke	20÷80 mm	300
	Wióry / Wood chips / Holzhacksnitzel	5÷30 mm	
	Piasek / Sand / Sand Żwir / Gravel / Kies	0,25÷8 mm	
h<3 m	Kora / Bark / Borke	20÷80 mm	400
	Wióry / Wood chips / Holzhacksnitzel	5÷30 mm	
	Piasek / Sand / Sand Żwir / Gravel / Kies	0,25÷8 mm	
h<3 m	Nawierzchnia syntetyczna / Synthetic granulates / Synthetische Oberfläche	wg danych producenta acc. to the manufacturer's data nach Angaben des Herstellers	

Posadowienie / Foundation / Gründung / Fondation	1938
--	------

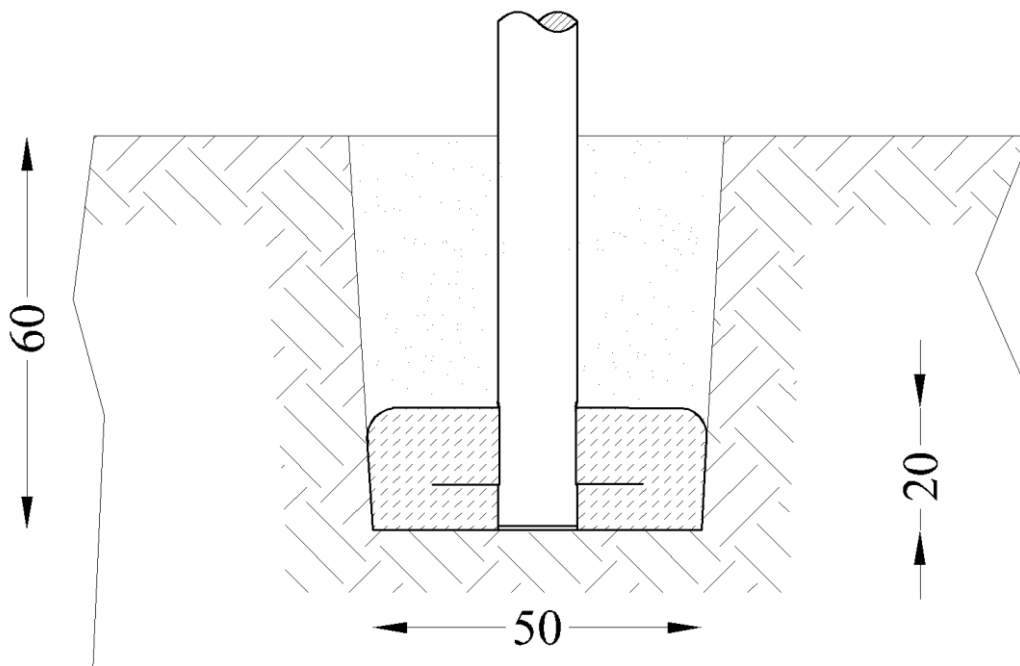

Beton / Concrete / Beton: **C16/20** - m³

W celu kontroli fundamentów należy usunąć nawierzchnię bezpieczną / piasek / żwir etc.

In order to control the foundations, remove the safe surface (sand, gravel, etc.)

Um die Fundamente zu überprüfen, entfernen Sie den Fallschutzbelag: Sand/ Kies etc.

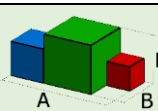
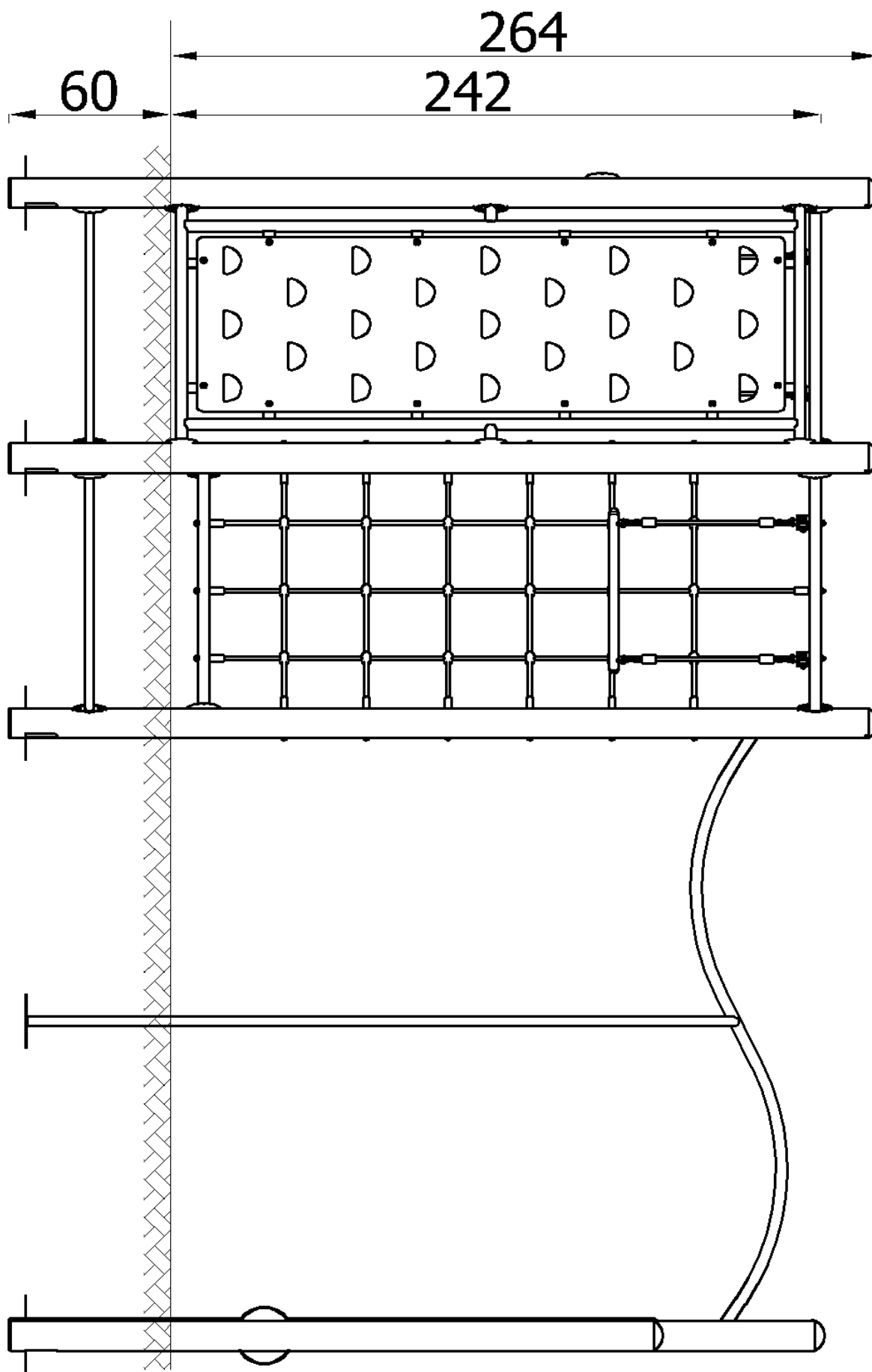

4,51x3,31x2,64
(AxBxH) [m]

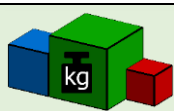

350 kg

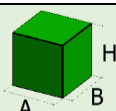

0,1x0,1x3,24
(AxBxH) [m]



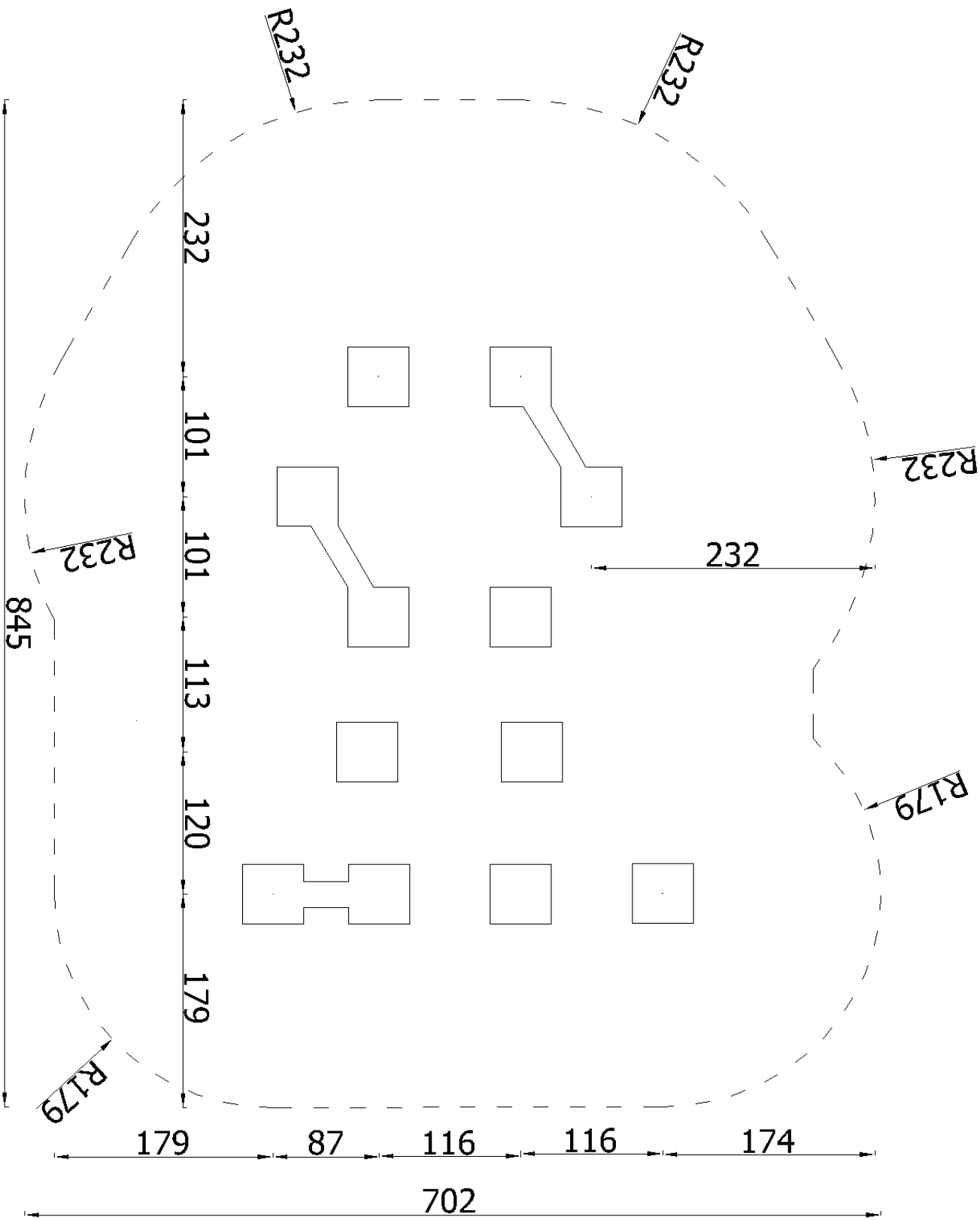

48 kg

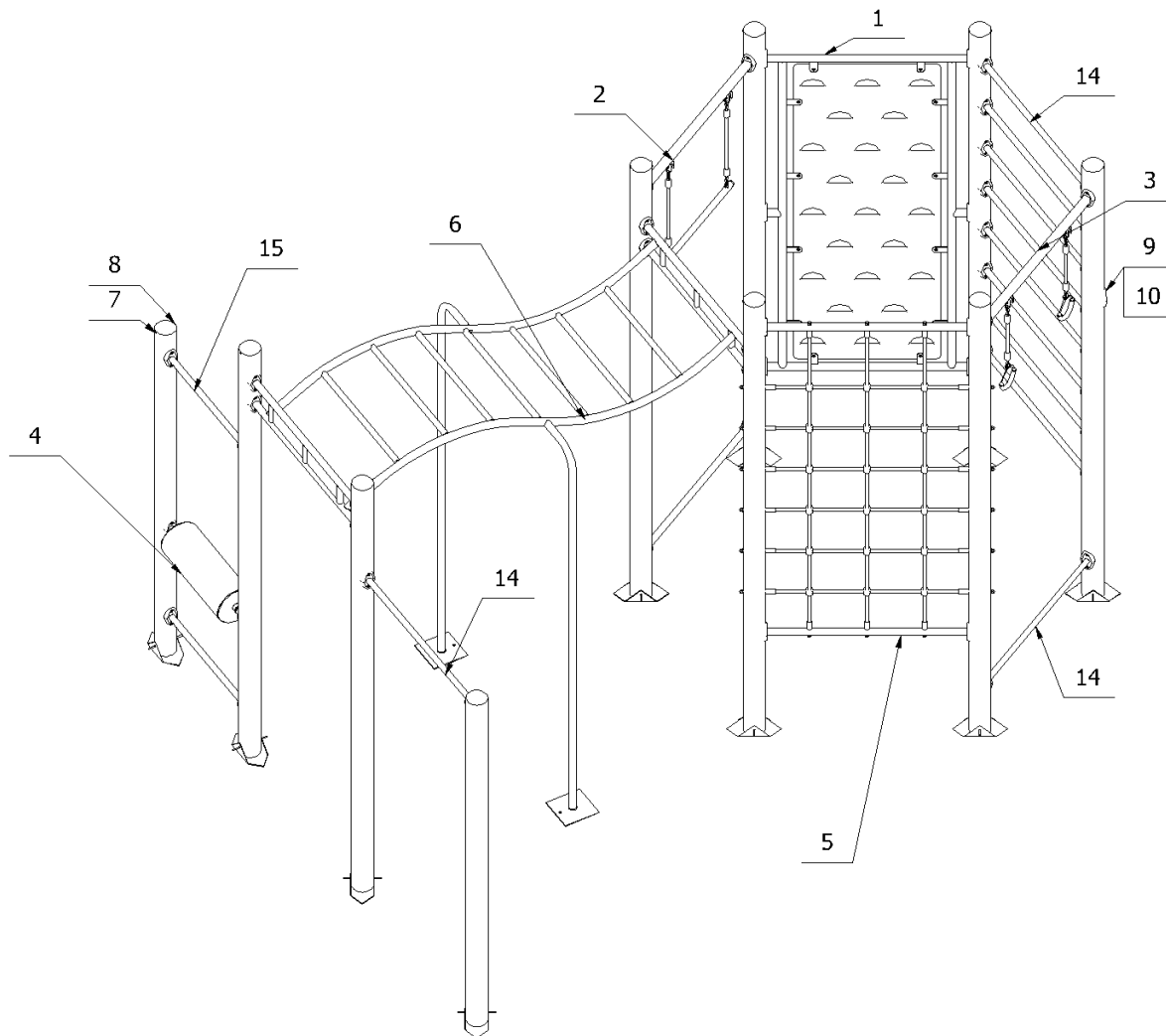



Części zamienne dostępne u producenta. Stosować klej do gwintów w połączeniach śrubowych.
Spare parts available from the manufacturer. Use thread glue in screw connections.
Ersatzteile beim Hersteller erhältlich. Gewindekleber für Schraubverbindungen verwenden.

16	Zestaw słupów wierconych	1938N/1 - 1938N/10	1kpl.				
15	Drążek 75cm	2772N	2				
14	Drążek 104cm	26123N	11				
13	Śruba z łbem podkładkowym	ISO7380_2_M8x16_A2	2				
12	Pręt 6x200 mm	8850_002	10				
11	Blacha 3x283x283	B_8802_025	10				
10	Tabliczka znamionowa pionowa	8918_002	1				
9	Wkładka łezka wklęsła	8919_001	2				
8	Zaślepka kołpakowa rury114,3	8912_120	10				
7	Nit zrywalny	DIN7337_A5x10	20				
6	Drabinka fala A4K	2264N	1				
5	Ścianka wspinaczkowa z lin A4K	23235N	1				
4	Walec A4K	26111N	1				
3	Kółka gimnastyczne A4K	26133N	1				
2	Drążek gimnastyczny A4K	26132N	1				
1	Ścianka wspinaczkowa A-Q026	23208N	1				
Lp. Art. Nr.	No. Rep.	Nazwa części Teilename	Part name Nom de la pièce	Nr części Teile-Nr	Part No. Partie No.	Ilość Anzahl	Quantity Nombre

															
								5 m	30 m						
															
2,5 m				60 cm	100 cm										
															
				7 mm								13 mm	17 mm	19 mm	24 mm
															
13 mm	17 mm	19 mm	24 mm	4 mm	5 mm	6 mm	8 mm	T40				T45			
															

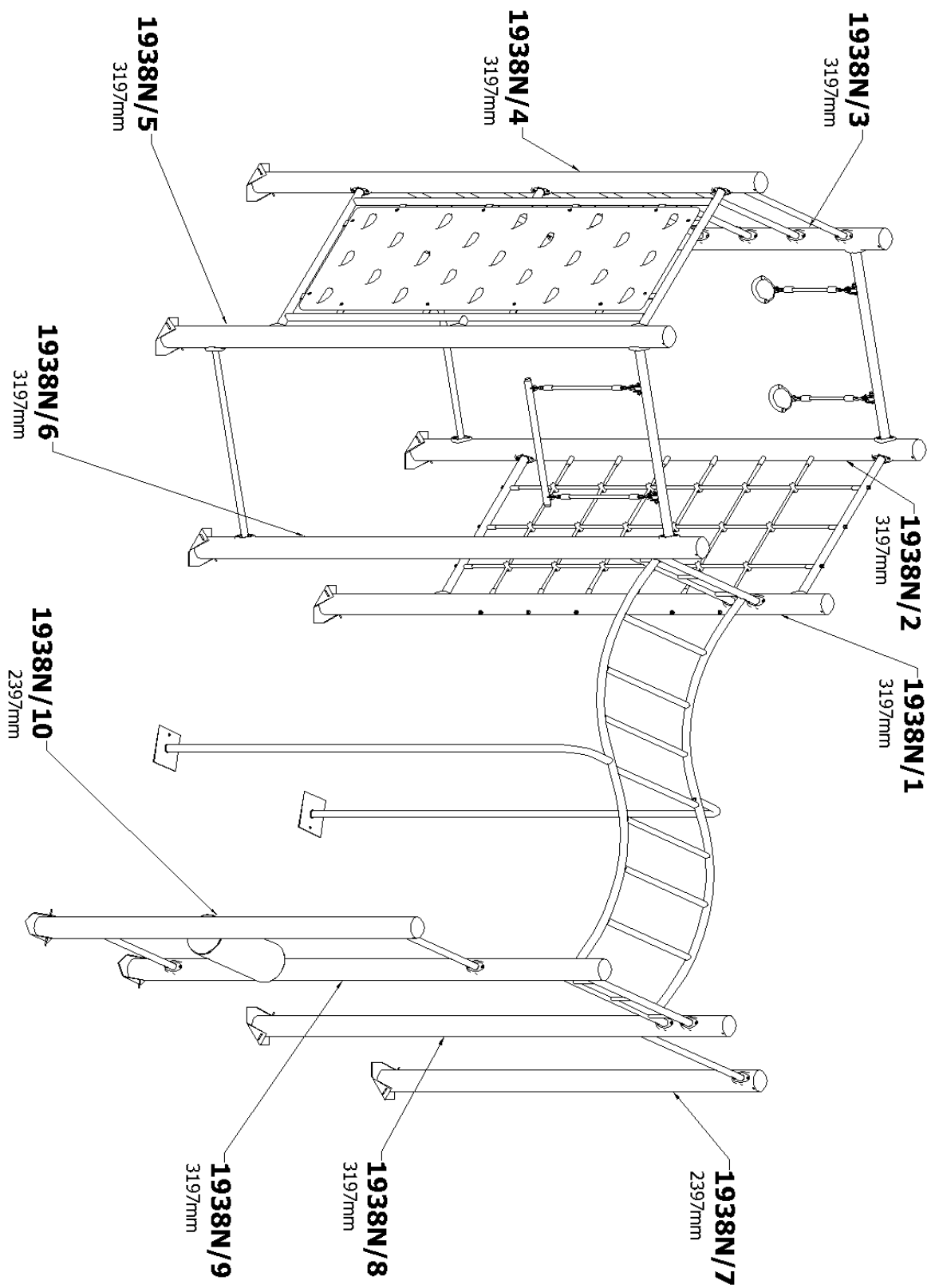

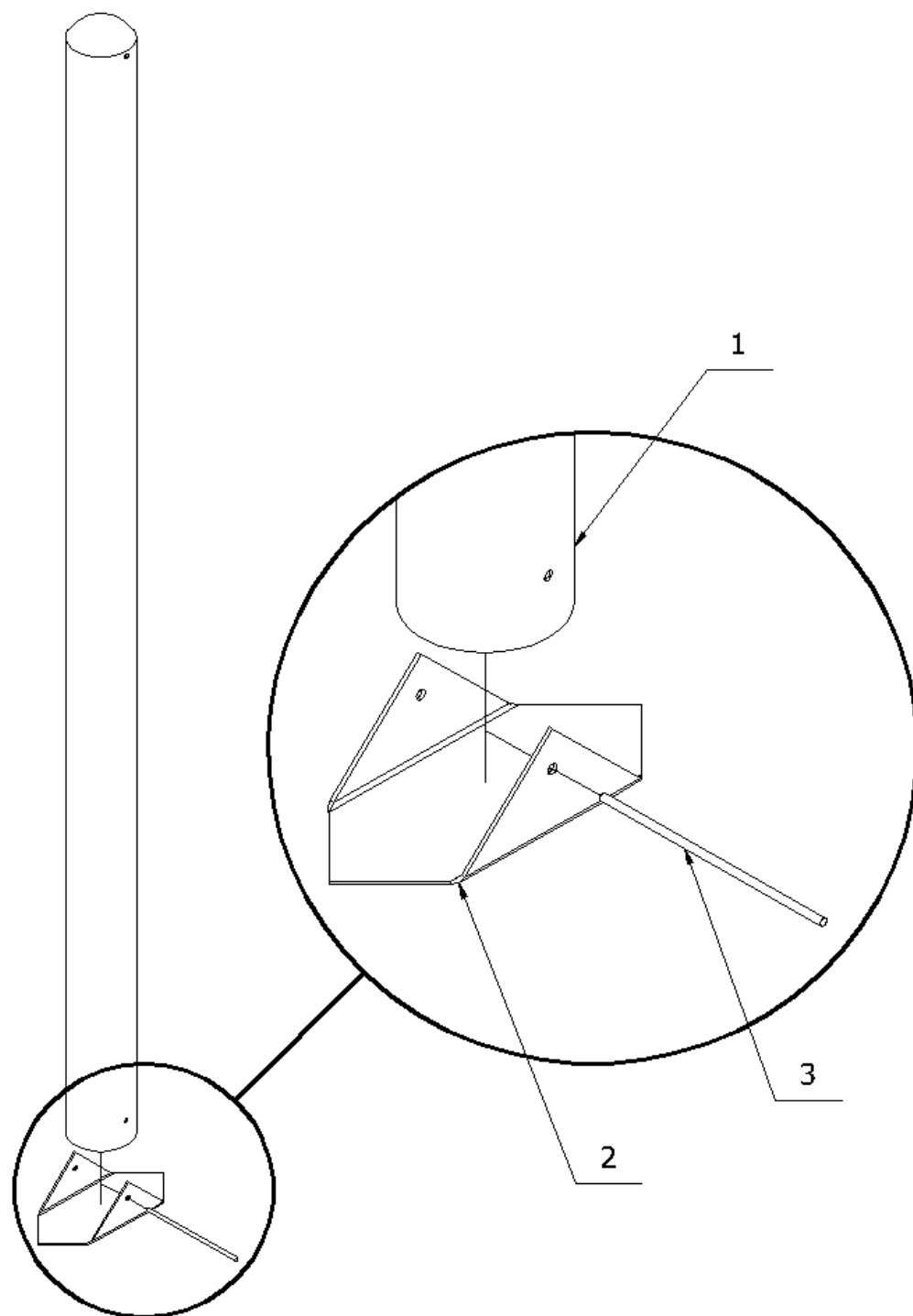
SŁUP / POLE

3	8850_002	1
2	B_8802_025	1
1	SŁUP/ POLE	1
Nr.	Nr Rys./Normy	Ilość

23208N

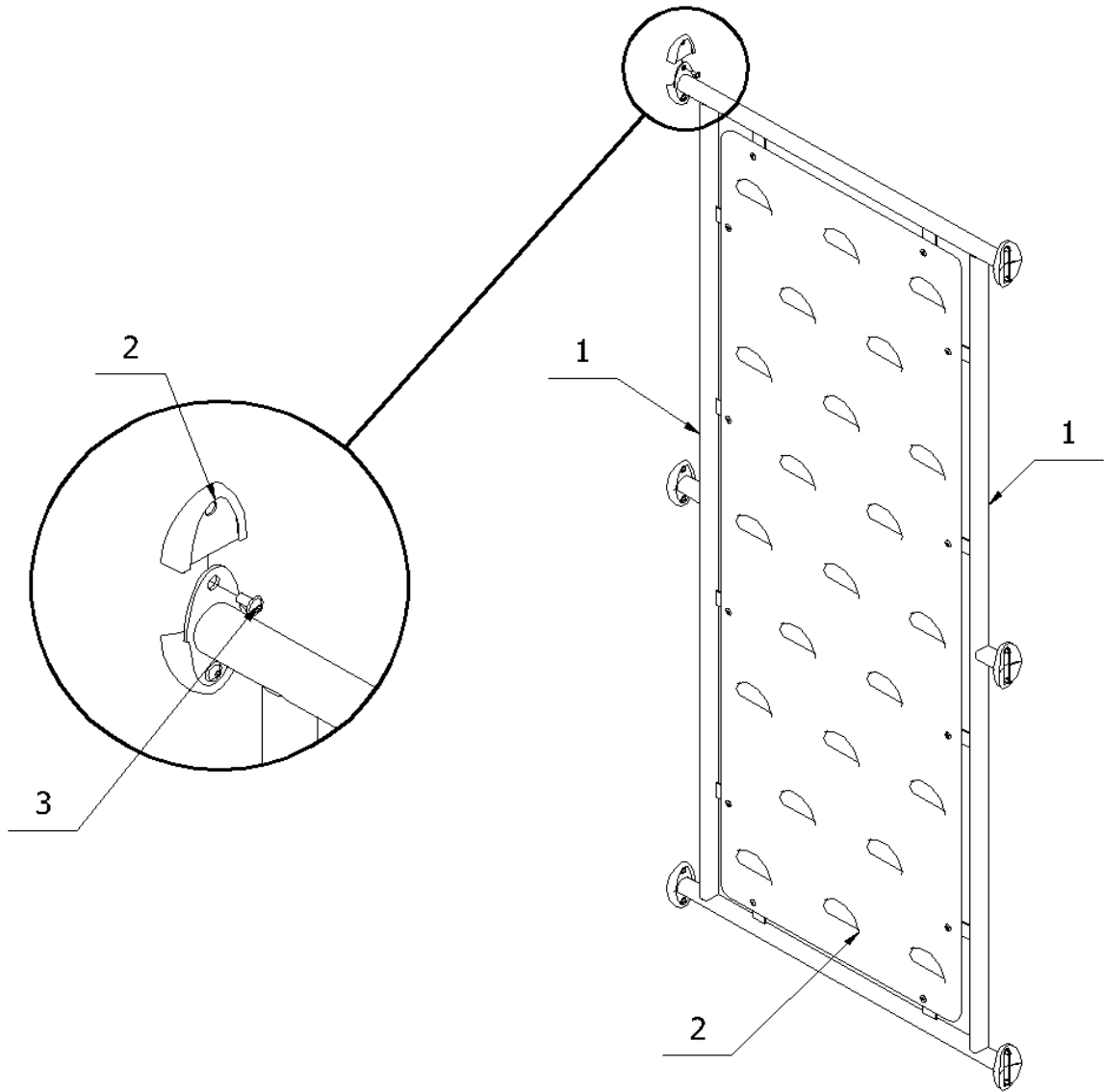

3	ISO7380_2_M8x16_A2	12
2	8919_001	12
1	L23208_001 + E_23208_002	1
Nr.	Nr Rys./Normy	Ilość

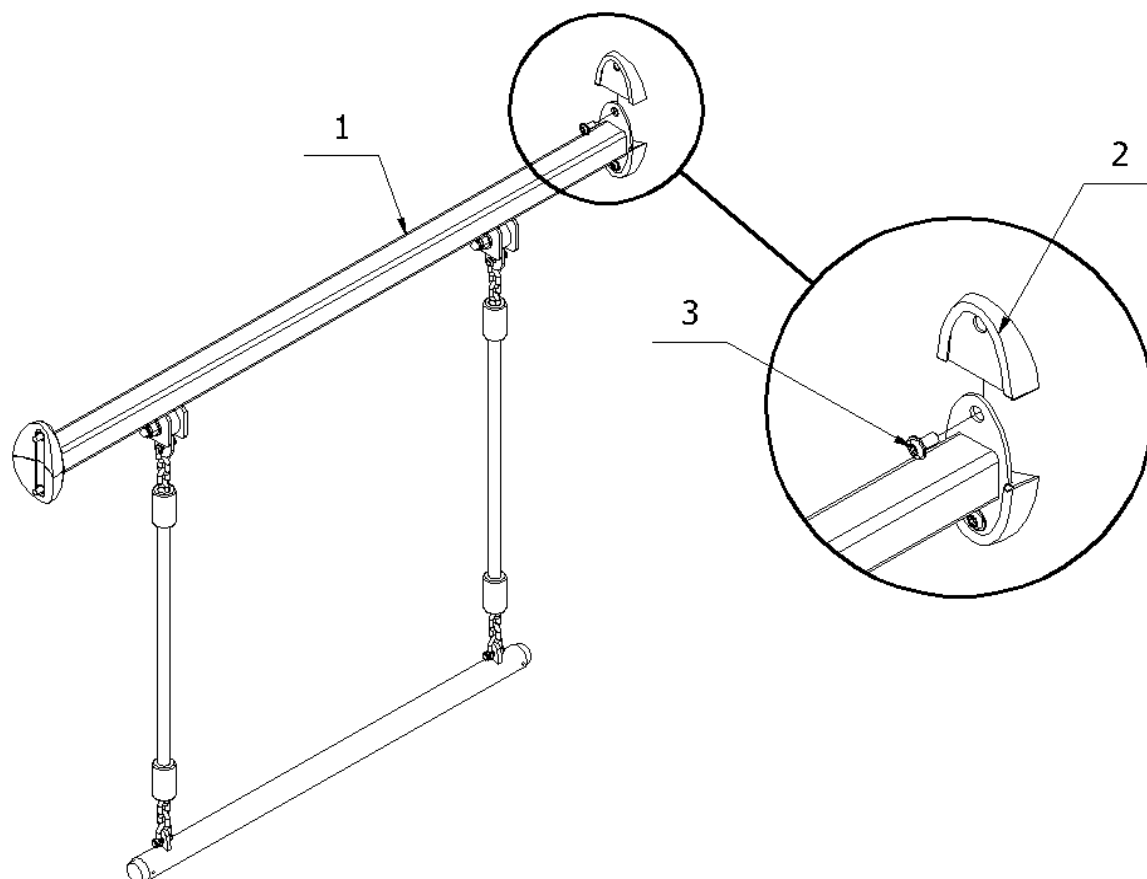
26132N

3	ISO7380_2_M8x16_A2	4
2	8919_001	4
1	L26133_002 + L26132_002	1
Nr.	Nr Rys./Normy	Ilość

26133N

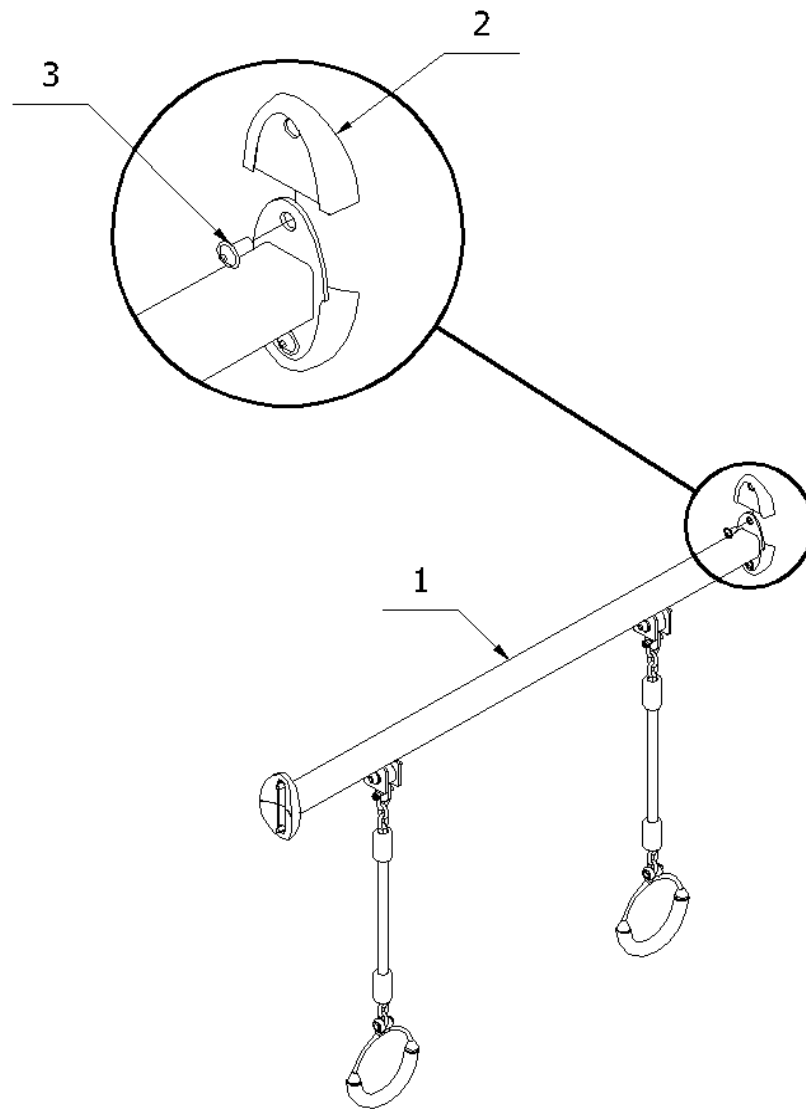

3	ISO7380_2_M8x16_A2	4
2	8919_001	4
1	26133	1
Nr.	Nr Rys./Normy	Ilość

26133N

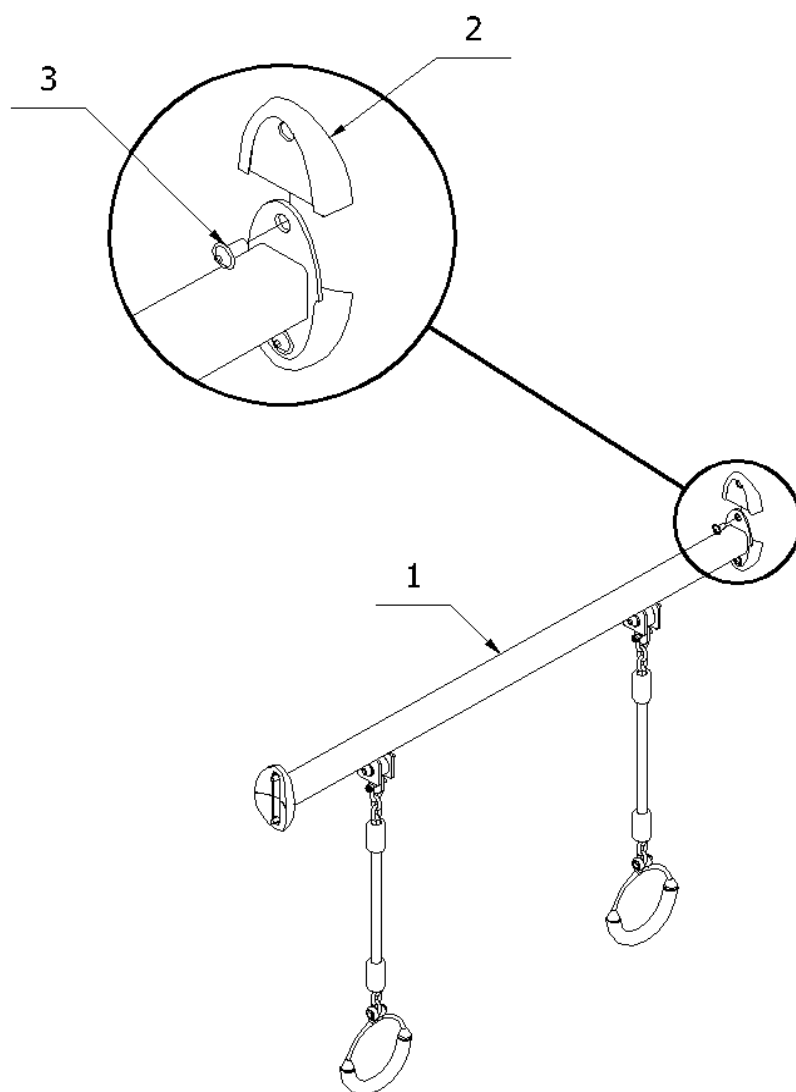

3	ISO7380_2_M8x16_A2	4
2	8919_001	4
1	26133	1
Nr.	Nr Rys./Normy	Ilość

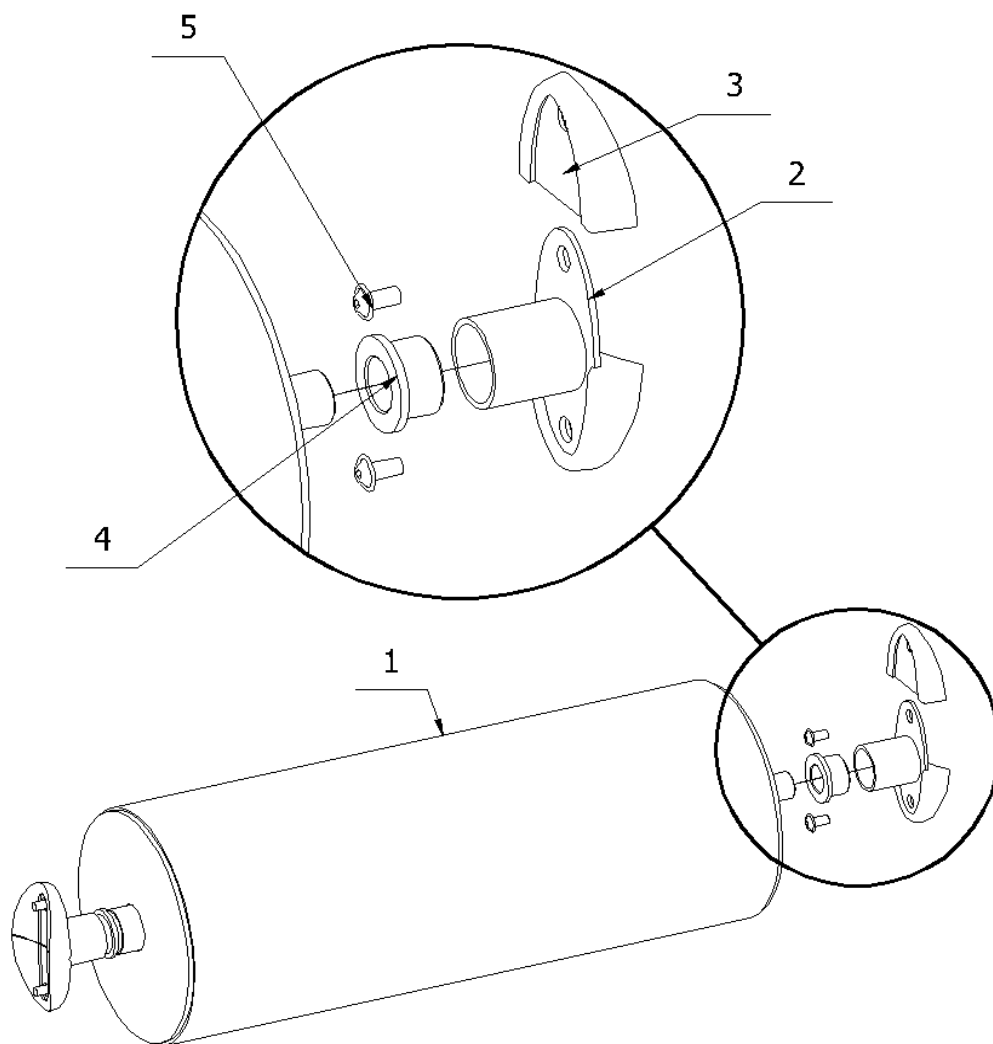
26111N

5	ISO7380_2_M8x16_A2	4
4	8911_107	2
3	8919_001	4
2	L26111_002	2
1	L26111_001	1
Nr.	Nr Rys./Normy	Ilość

23235N

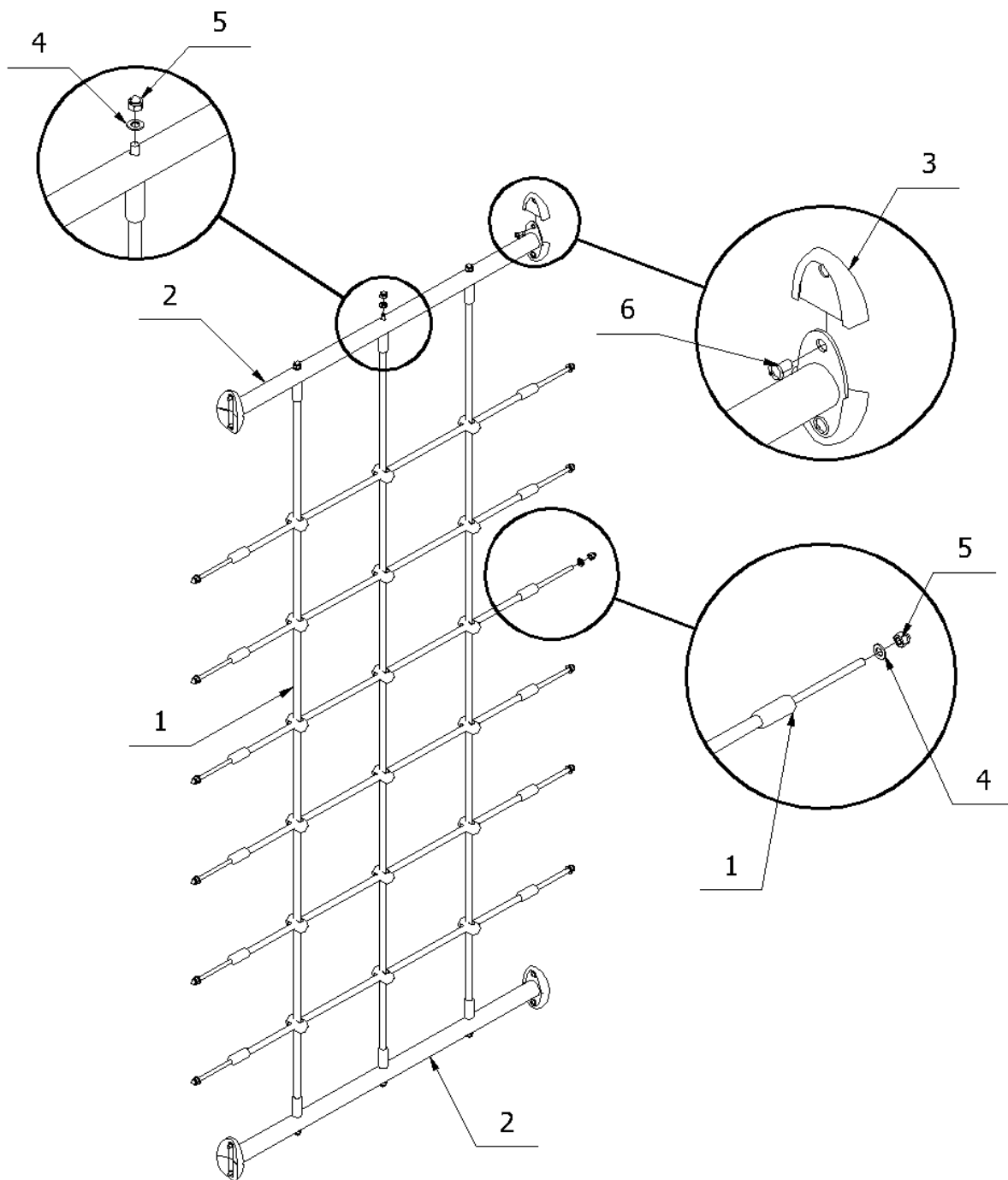

6	ISO7380_2_M8x16_A2	8
5	DIN986_M10_A2	18
4	ISO7089_10_A2	18
3	8919_001	8
2	L23235_001	2
1	L23235_002	1
Nr.	Nr Rys./Normy	Ilość

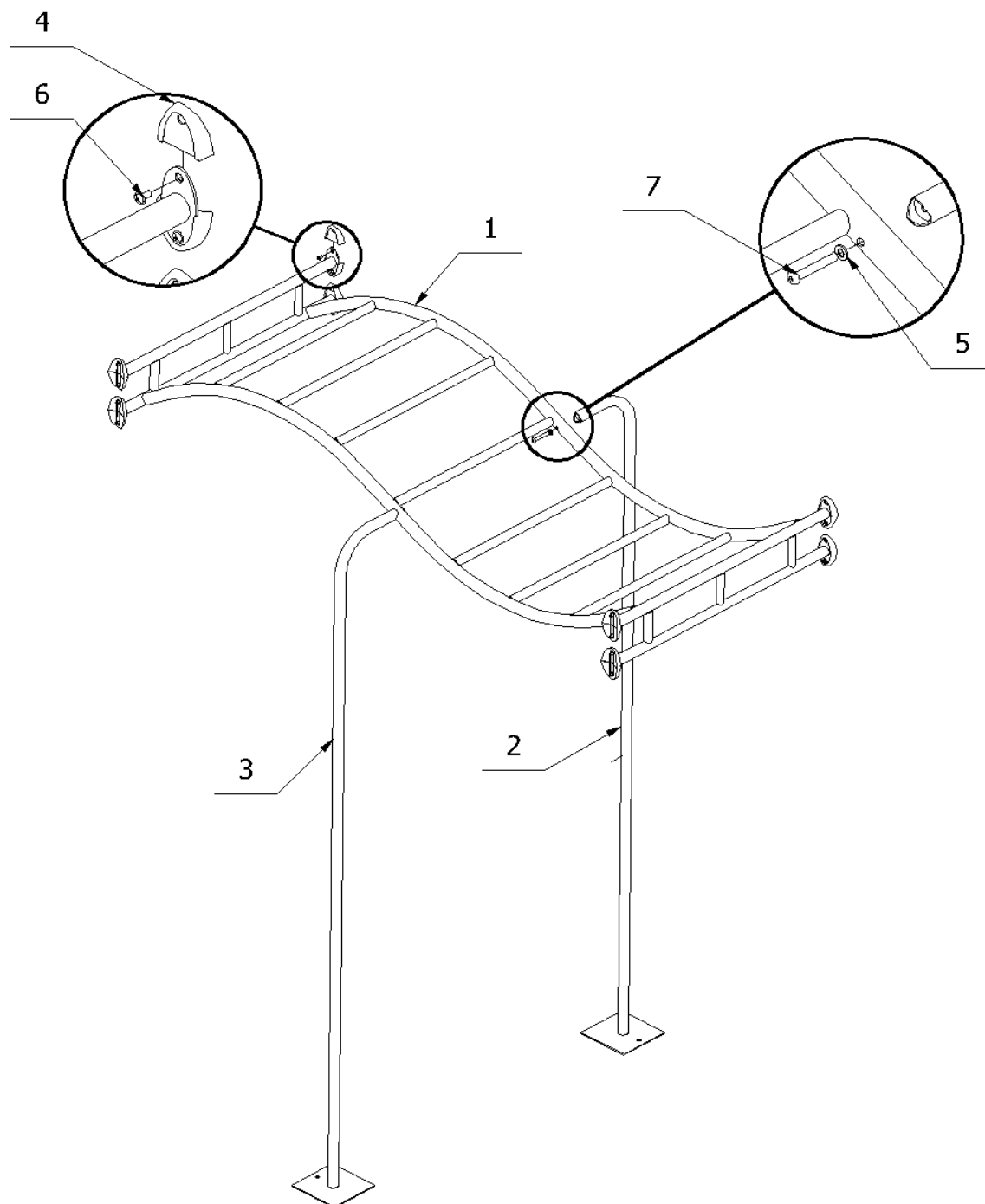
2264N

7	ISO7380_M10x70_A2	2
6	ISO7380_2_M8x16_A2	16
5	ISO7089_10_A2	2
4	8919_001	16
3	L2264_002P	1
2	L2264_002L	1
1	L2264_001	1
Nr.	Nr Rys./Normy	Ilość

26123N

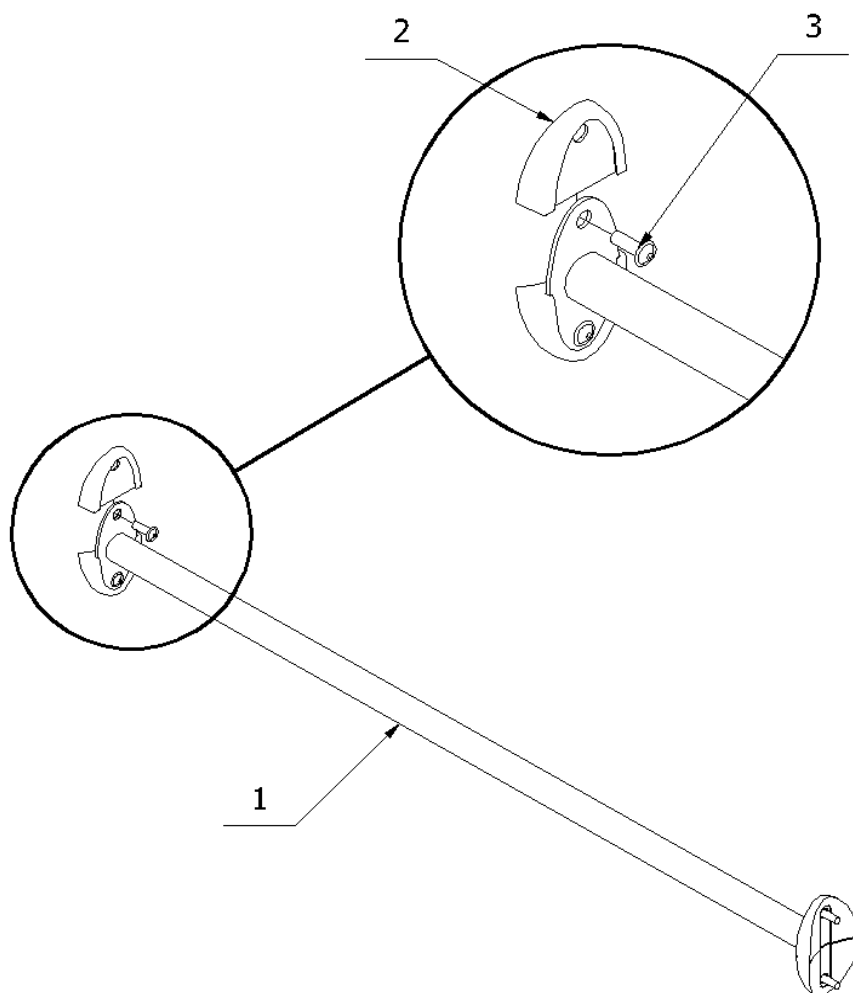

3	ISO7380_2_M8x25_A2	4
2	8919_001	4
1	L26123_001	1
Nr.	Nr Rys./Normy	Ilość

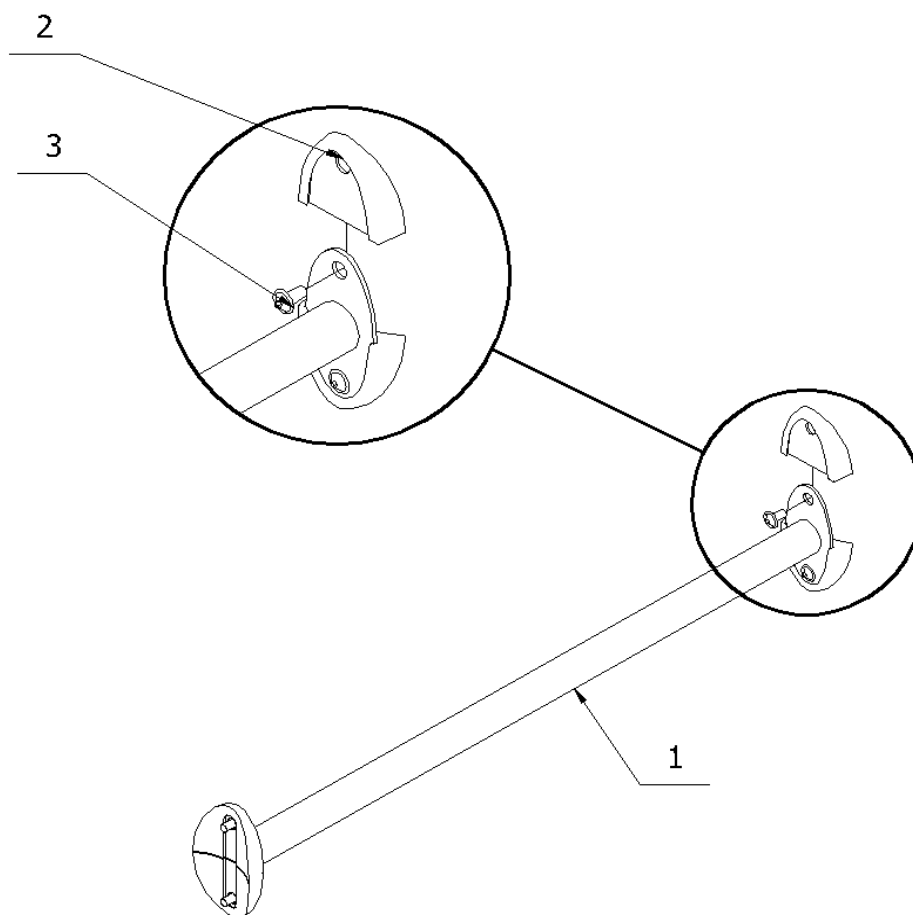
2772N

3	ISO7380_2_M8x16_A2	4
2	8919_001	4
1	L2772_001	1
Nr.	Nr Rys./Normy	Ilość