



INFORMATION	
Number of users	4
Age range	1 - 14
Device dimensions [m]	0.81 x 0.81 x 1.51
Compliance with the norm	PN-EN 1176-1+A1:2024-03
Max height of fall [m]	0
Perimeter of safety zone [m]	12
Area [m <sup>2</sup> ]	12.5



Fun



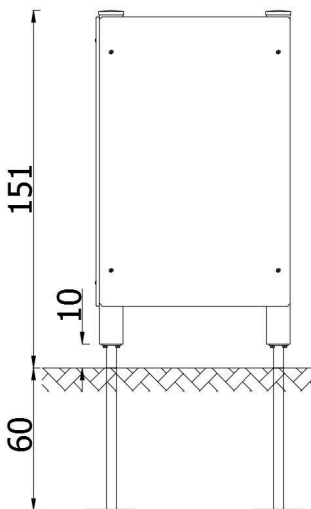
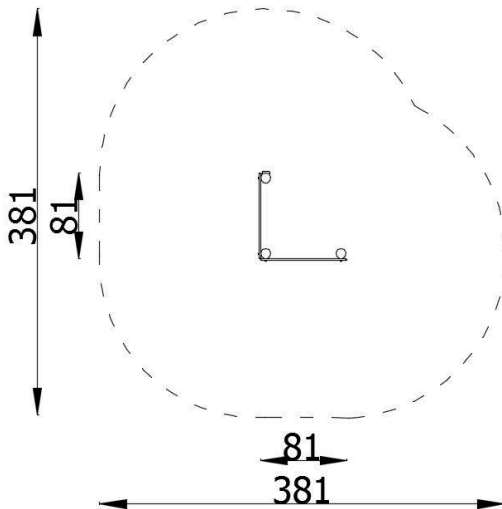

### Material Description:

- Square load-bearing posts with a cross-section of 90x90 mm made of laminated wood with longitudinal grooves;
- Panel made of plywood covered with black HPL;
- Posts mounted on galvanized steel anchors that isolate the wood from the ground. Anchored below ground level. Foundation according to the installation instructions;

### Set Composition:

- 2 x drawing board

### Series Description:

Complementary equipment such as spring rockers, swings, slides, carousels, and sandpits are an essential part of every playground, making it even more attractive and functional. Each of these elements encourages physical activity and creative outdoor play while supporting children's motor and social development.

SAFETY SURFACE			
Zone	Max height of fall [m]	Area [m <sup>2</sup> ]	Perimeter of safety zone [m]
A	-	12	12.5
B			
C			

The visualizations are for illustrative purposes only; the actual appearance and colors of the equipment may vary. Novum reserves the right to make structural and color modifications as part of its commitment to continuous product improvement.

