



PL	INSTRUKCJA MONTAŻU	Nazwa	Tablica koła fortuny	Nr kat.	3611
ENG	ASSEMBLY INSTRUCTIONS	Product	The wheel of fortune	Cat. no.	
DEU	MONTAGEANLEITUNG	Name		Art.-Nr.	
FRA	INSTRUCTIONS D'INSTALLATION	Catégorie		Référence:	

3611



Wiek użytkowników Age of users Altersgruppe	Ilość użytkowników Number of users Anzahl der Benutzer Nombre d'utilisateurs	Przeznaczenie urządzenia Purpose of device Bestimmung des Spielgerätes	Zgodność z normą In accordance with the standard Geltende Norm
0-14	2	do zabawy na zewnątrz for outdoor playing zum draußen Spielen	PN-EN 1176-1:2017
NOVUM Sp. z o.o. Sp. k. ul. Bolesława Chrobrego 1, 12-100 Szczytno		e-mail: biuro@novumedukacja.pl	www.novumedukacja.pl
NOVUM Sp. z o.o. Sp. k. ul. Bolesława Chrobrego 1, 12-100 Szczytno		e-mail: eksport@novumgrom.com	www.novum4kids.com
NOVUM Deutschland GmbH, Schiffgesweg 11, 50259 Pulheim		e-mail: service@novum4kids.de	www.novum4kids.de
NOVUM DIRECT France Centre Commerciale La Samiane 01290 CROTTET		e-mail: contact@novum-direct.fr	www.novum-direct.fr

UWAGA / WARNING / ACHTUNG / ATTENTION:

PL Jeżeli w zestawie występuje zjeżdżalnia, zestaw należy posadzić w taki sposób, aby ślizg zjeżdżałni znajdował się od strony północnej, czyli od strony nienasłonecznionej, aby zapobiegać nadmiernemu nagrzewaniu się ślizgu.

ENG If there is a slide in the set, it should be installed from the north, poorly sunny side to avoid possible hazards (burns) through direct skin contact.

DEU Wenn eine Spielplatzanlage eine Rutsche enthält, sollte diese Anlage so platziert werden, dass die Rutsche sich auf der Nordseite befindet, dh. auf der schattigen Seite, um übermäßige Erwärmung der Rutschbahn zu vermeiden.

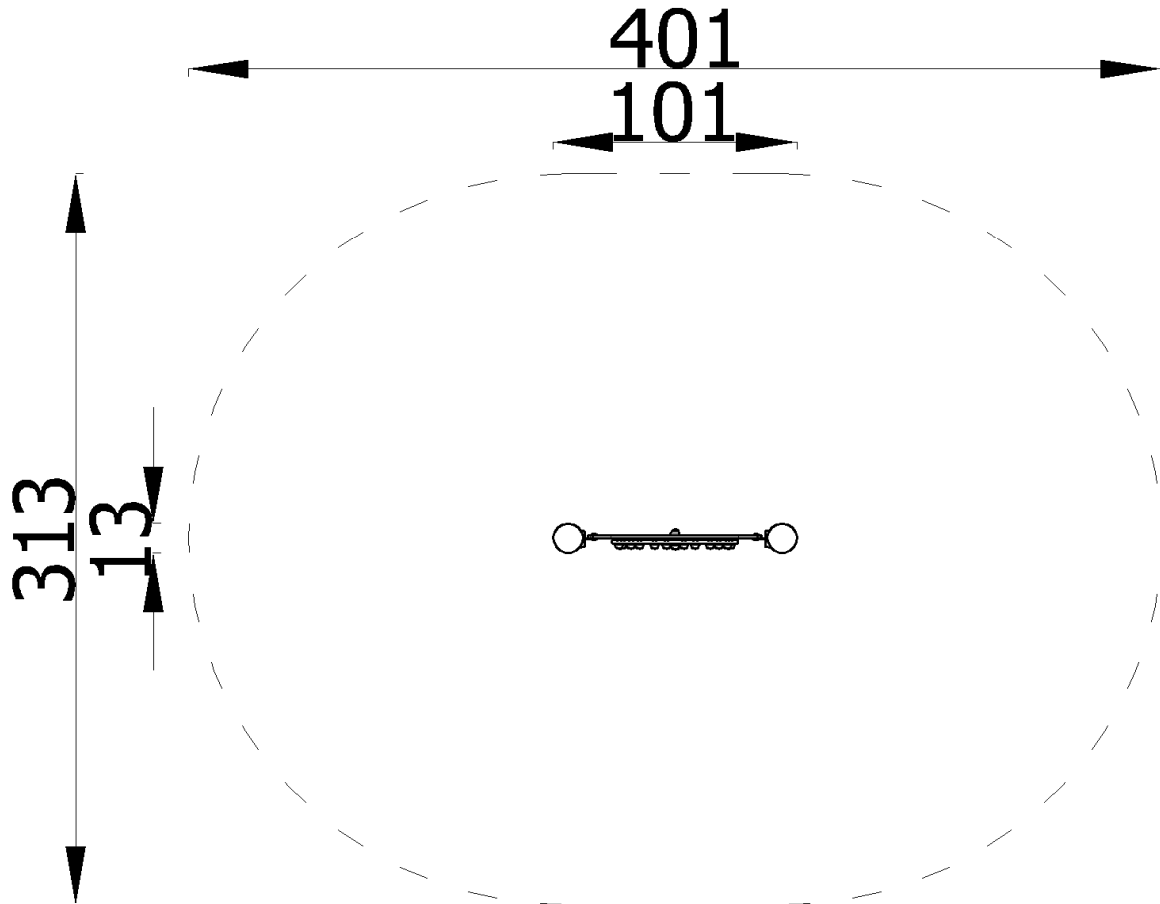

Montaż zgodnie z planem zagospodarowania terenu.
 Installation in accordance with the land development plan.
 Montage gemäß dem Flächennutzungsplan

Bezpieczna nawierzchnia / Safe surface / Safe Oberfläche / Surface sûre

Strefa Zone Zone Zone	Max. wysokość upadku Max. fall height Max. Fallhöhe Max. hauteur de chute	Pole powierzchni Surface area Fläche Surface	Obwód strefy bezpiecz. Perimeter security zone Umkreis der Fallschutzfläche Zone de périmètre de sé.
A	-	10,50 m ²	12,00 m
B	-	-	
C	-	-	

Nawierzchnia / Safe surface / Fallschutzbelag / fr			3611
	Material Material Material	Min. wysokość warstwy Min. layer thicknesses Min. Schichtöhe	
h<0,6 m	Beton / Concrete / Beton Nawierzchnia bitumiczna / Bituminous surfacing / Bituminöse Oberfläche		
h<1 m	Gleba / Topsoil / Boden Darń / Turf / Grasnarbe		
h<2 m	Kora / Bark / Borke	20÷80 mm	300
	Wióry / Wood chips / Holzackschnitzel	5÷30 mm	
	Piasek / Sand / Sand Żwir / Gravel / Kies	0,25÷8 mm	
h<3 m	Kora / Bark / Borke	20÷80 mm	400
	Wióry / Wood chips / Holzackschnitzel	5÷30 mm	
	Piasek / Sand / Sand Żwir / Gravel / Kies	0,25÷8 mm	
h<3 m	Nawierzchnia syntetyczna / Synthetic granulates / Synthetische Oberfläche	wg danych producenta acc. to the manufacturer's data nach Angaben des Herstellers	

Posadowienie / Foundation / Gründung / Fondation	3611
--	------

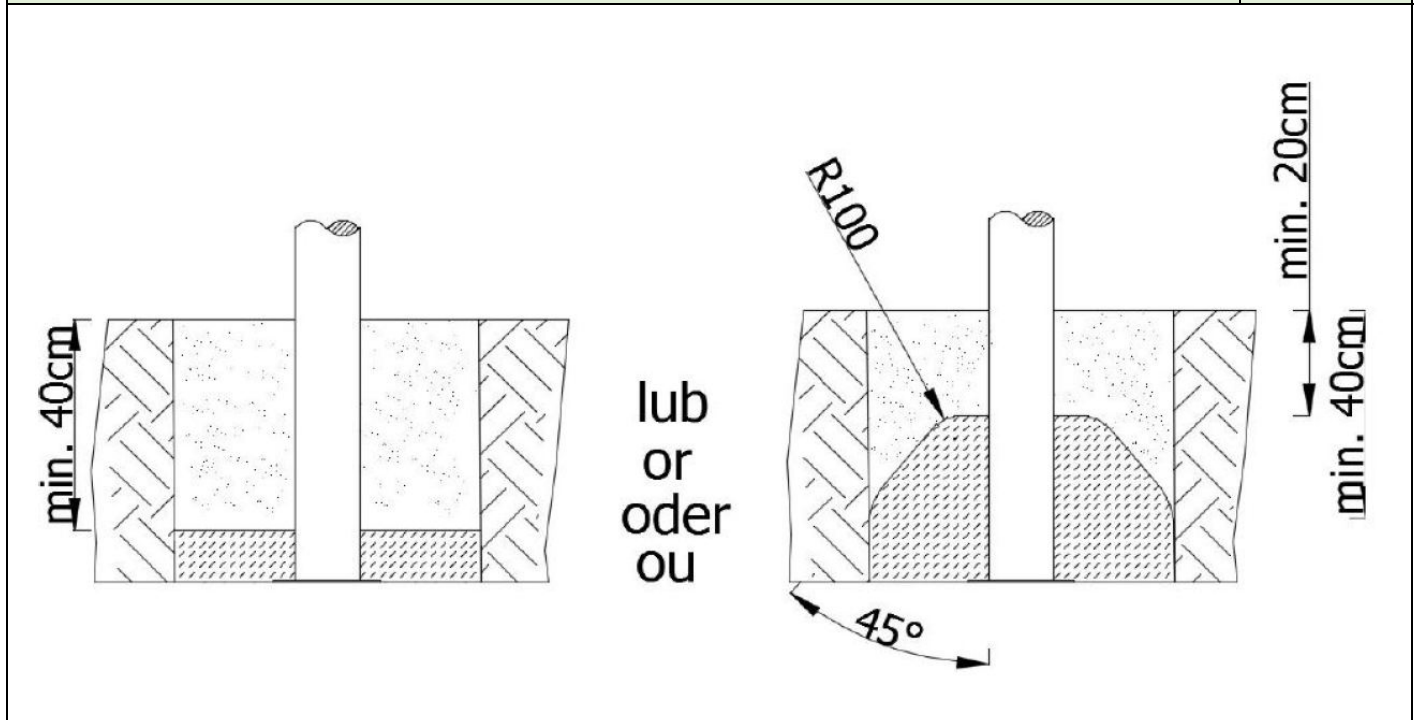

Beton / Concrete / Beton: **C16/20** - **0,06** m³

W celu kontroli fundamentów należy usunąć nawierzchnię bezpieczną / piasek / żwir etc.
 In order to control the foundations, remove the safe surface (sand, gravel, etc.)
 Um die Fundamente zu überprüfen, entfernen Sie den Fallschutzbelag: Sand/ Kies etc.

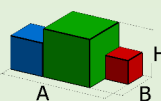
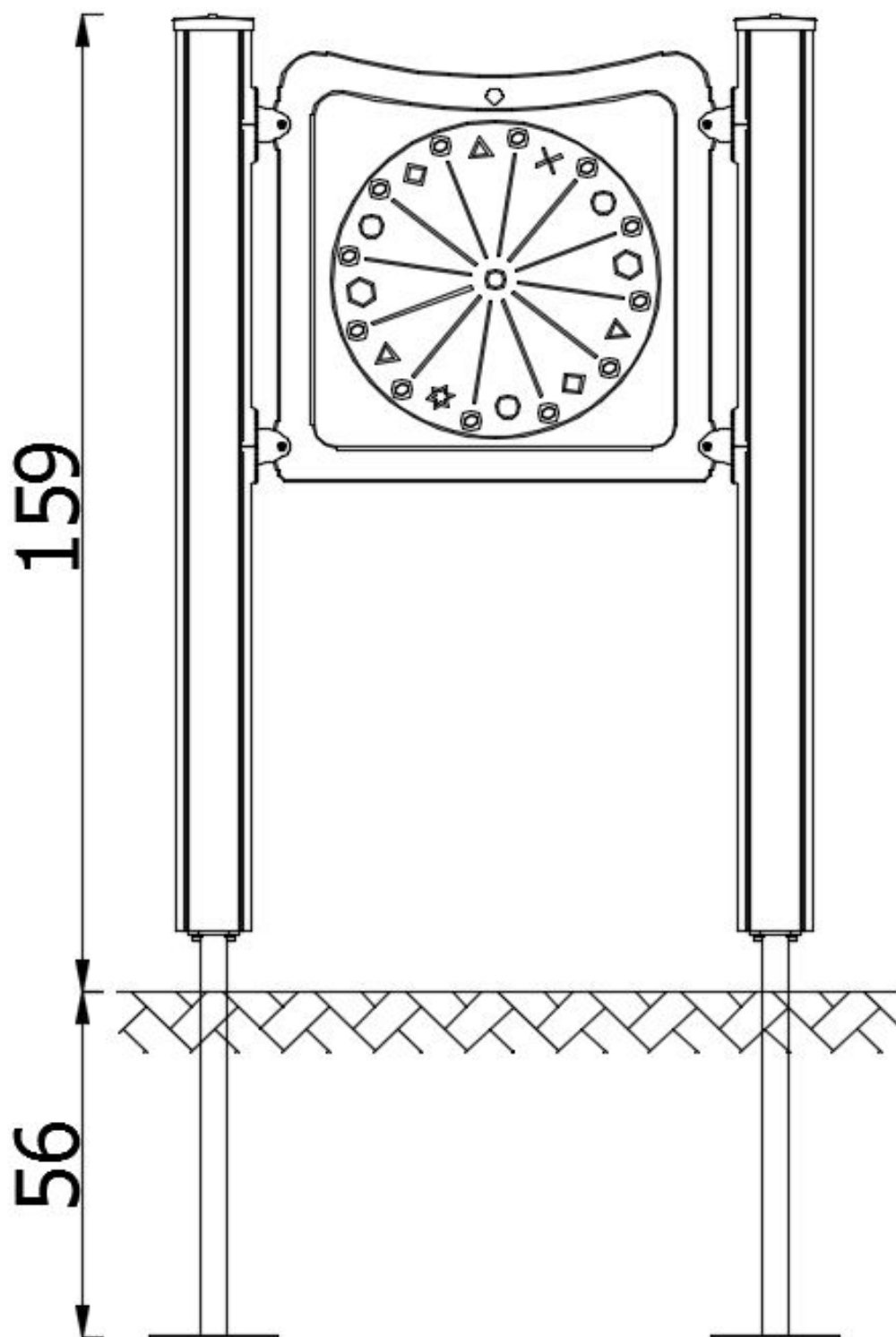

1,01 x 0,13 x 1,59
(AxBxH) [m]

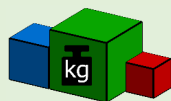

35,3 kg

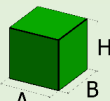

0,2 x 0,2 x 2,2
(AxBxH) [m]



13 kg

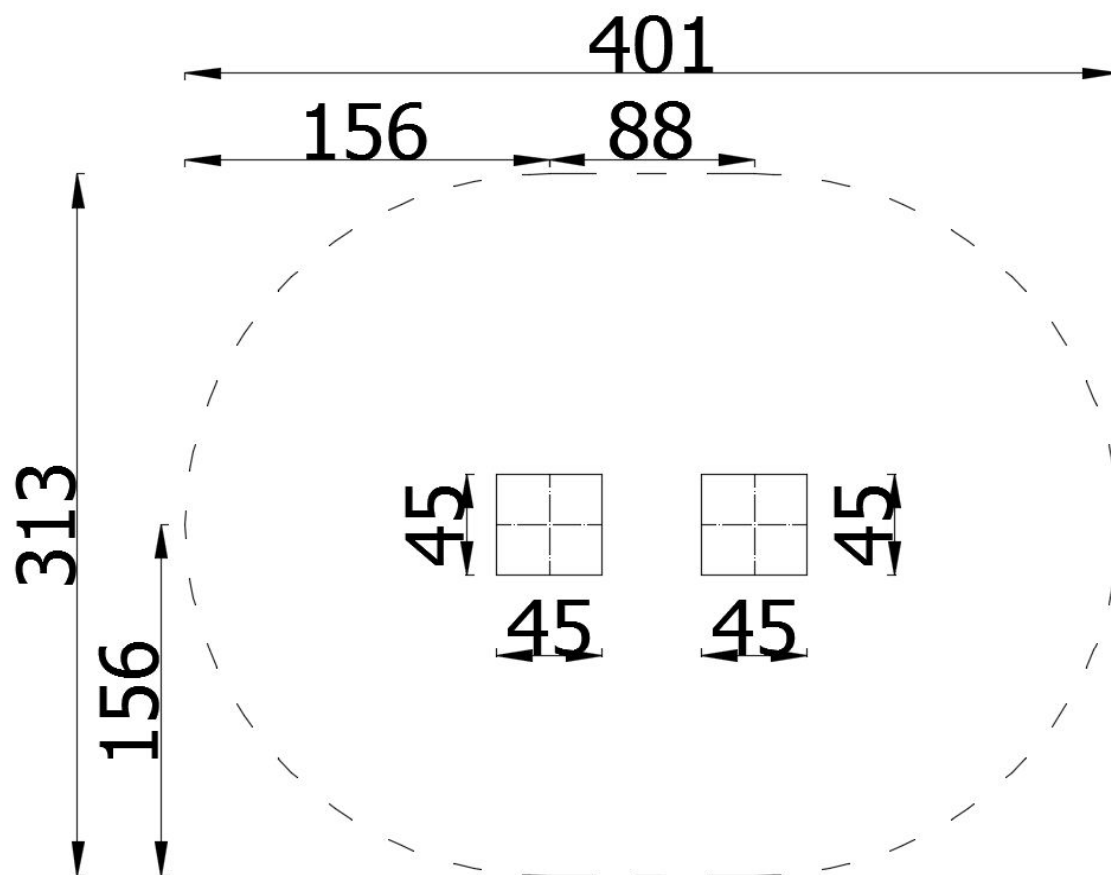

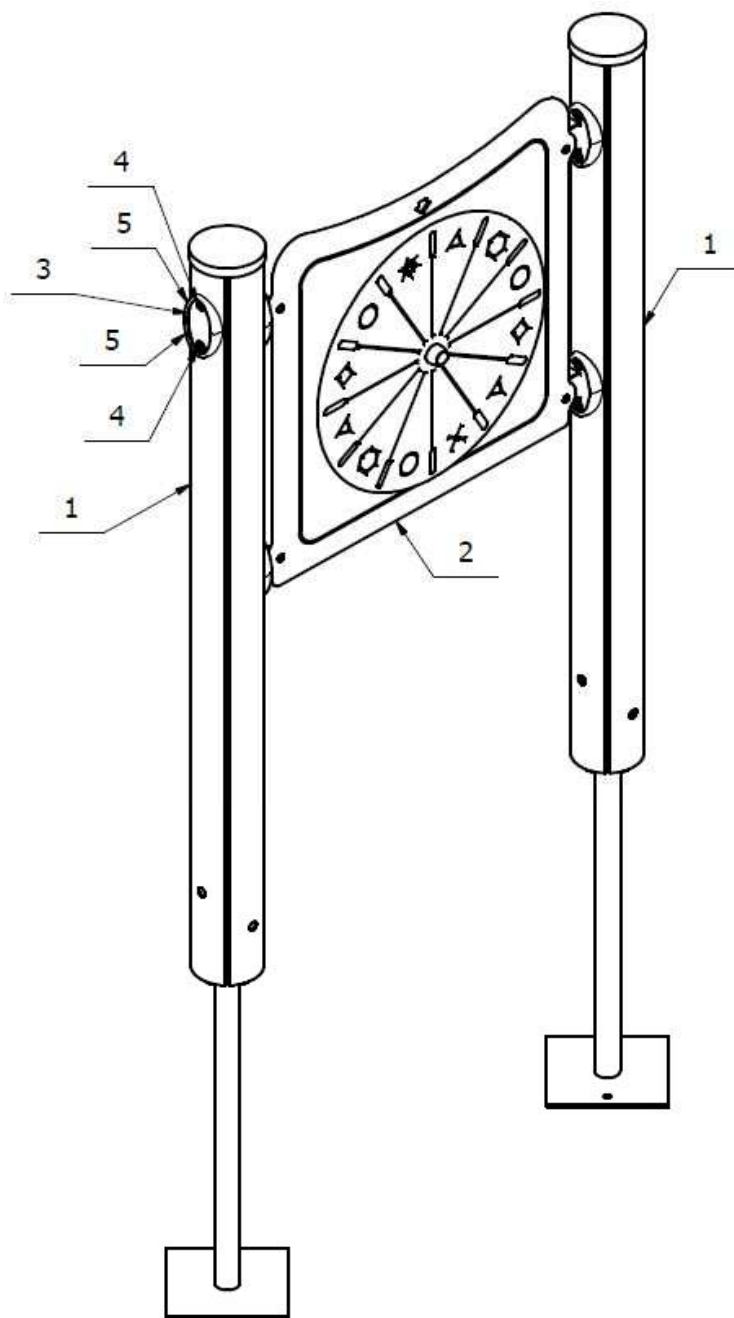





Części zamienne dostępne u producenta. Stosować klej do gwintów w połączeniach śrubowych.
Spare parts available from the manufacturer. Use thread glue in screw connections.
Ersatzteile beim Hersteller erhältlich. Gewindekleber für Schraubverbindungen verwenden.

- 1) Posadowienie słupów w przygotowanych otworach .
- 1) Put poles in prepared holes.
- 2) Skręcenie słupów z panelem, ustawienie w pionie i zabetonowanie.
- 2) Assemble poles with panel, set in vertical position and concreting.

5		Wkładka łezka wklęsła		8919_001		2	
4		Wkręt podkładkowy Torx 6x60		8905_003_6x60_A2		2	
3		Tabliczka znamionowa pionowa		8918_002		1	
2		Zabezpieczenie wysokie koło fortuny		2410_RD		1	
1		Słup		3611_001		2	
Lp.	No.	Nazwa części	Part name	Nr części	Part No.	Ilość	Quantity
Art. Nr.	Rep.	Teilename	Nom de la pièce	Teile-Nr	Partie No.	Anzahl	Nombre

Narzędzia / Tools / Handwerkzeug / Outils

3611

															
								5 m	30 m						
															
2,5 m				60 cm	100 cm										
															
				7 mm								13 mm	17 mm	19 mm	24 mm
															
13 mm	17 mm	19 mm	24 mm	4 mm	5 mm	6 mm	8 mm	T40				T45			
															

8905_001	8
8919_001	8
2410	1
Nr Rys./Normy	
Ilość	

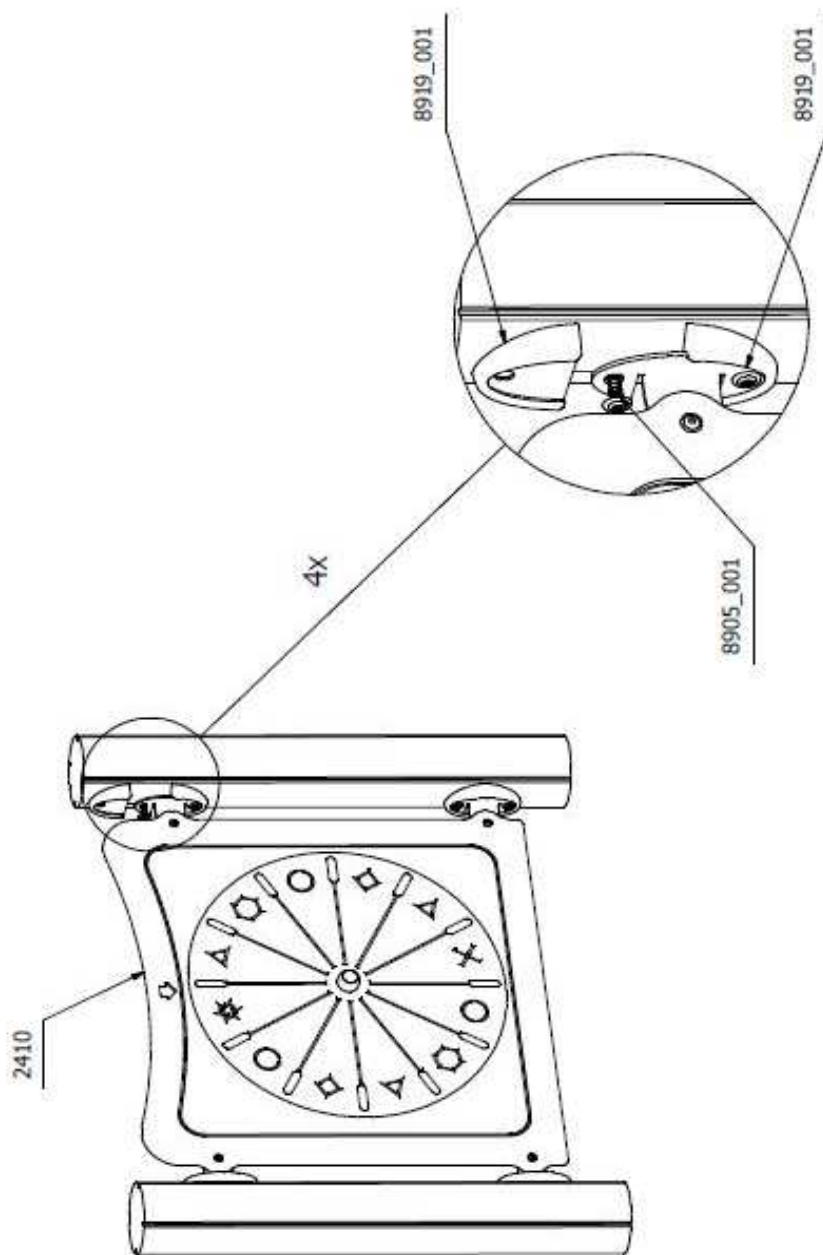

Nazwa / Product / Name

Zabezpieczenie wysokie koło fortuny

Nr Naz. / Cat. no. / Art. No.

2410_RD



06.04.2020

1 / 1