



PL	INSTRUKCJA MONTAŻU	Nazwa	Równoważnia	Nr kat.	4208E
ENG	ASSEMBLY INSTRUCTIONS	Product	Balance Beam	Cat. no.	
DEU	MONTAGEANLEITUNG	Name		Art.-Nr.	
FRA	INSTRUCTIONS D'INSTALLATION	Catégorie		Référence	

## 4208E



Wiek użytkowników Age of users Altersgruppe	Ilość użytkowników Number of users Anzahl der Benutzer Nombre d'utilisateurs	Przeznaczenie urządzenia Purpose of device Bestimmung des Spielgerätes	Zgodność z normą In accordance with the standard Geltende Norm
3-14	5	do zabawy na zewnątrz for outdoor playing zum draußen Spielen	PN-EN 1176-1:2017
NOVUM Sp. z o.o. Sp. k. ul. Bolesława Chrobrego 1, 12-100 Szczytno		e-mail: <a href="mailto:biuro@novumedukacja.pl">biuro@novumedukacja.pl</a> <a href="http://www.novumedukacja.pl">www.novumedukacja.pl</a>	
NOVUM Sp. z o.o. Sp. k. ul. Bolesława Chrobrego 1, 12-100 Szczytno		e-mail: <a href="mailto:eksport@novumgrom.com">eksport@novumgrom.com</a> <a href="http://www.novum4kids.com">www.novum4kids.com</a>	
NOVUM Deutschland GmbH, Schiffgesweg 11, 50259 Pulheim		e-mail: <a href="mailto:service@novum4kids.de">service@novum4kids.de</a> <a href="http://www.novum4kids.de">www.novum4kids.de</a>	
NOVUM DIRECT France Centre Commerciale La Samiane 01290 CROTTET		e-mail: <a href="mailto:contact@novum-direct.fr">contact@novum-direct.fr</a> <a href="http://www.novum-direct.fr">www.novum-direct.fr</a>	

**UWAGA / WARNING / ACHTUNG / ATTENTION:**

**PL** Jeżeli w zestawie występuje zjeżdżalnia, zestaw należy posadzić w taki sposób, aby ślizg zjeżdżałni znajdował się od strony północnej, czyli od strony nienasłonecznionej, aby zapobiegać nadmiernemu nagrzewaniu się ślizgu.

**ENG** If there is a slide in the set, it should be installed from the north, poorly sunny side to avoid possible hazards (burns) through direct skin contact.

**DEU** Wenn eine Spielplatzanlage eine Rutsche enthält, sollte diese Anlage so platziert werden, dass die Rutsche sich auf der Nordseite befindet, dh. auf der schattigen Seite, um übermäßige Erwärmung der Rutschbahn zu vermeiden.

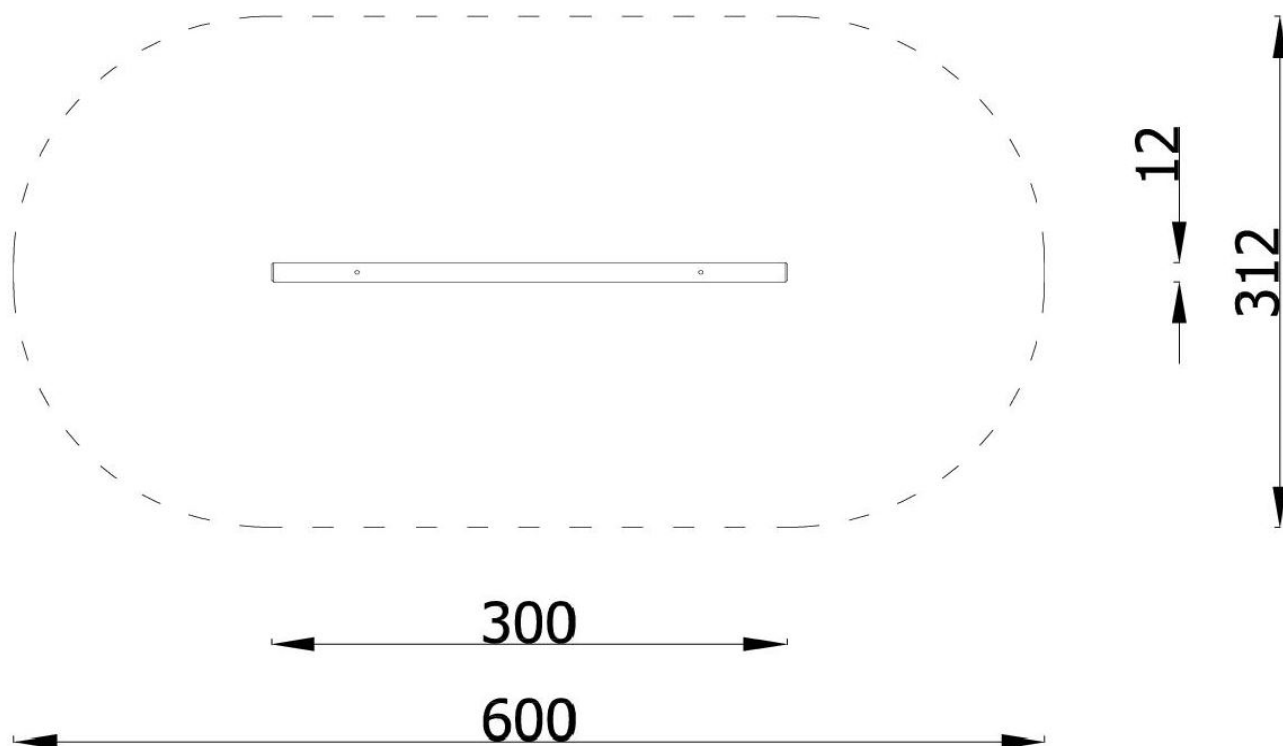

Montaż zgodnie z planem zagospodarowania terenu.  
 Installation in accordance with the land development plan.  
 Montage gemäß dem Flächennutzungsplan

Bezpieczna nawierzchnia / Safe surface / Safe Oberfläche / Surface sûre

Strefa Zone Zone Zone	Max. wysokość upadku Max. fall height Max. Fallhöhe Max. hauteur de chute	Pole powierzchni Surface area Fläche Surface	Obwód strefy bezpiecz. Perimeter security zone Umkreis der Fallschutzfläche Zone de périmètre de sé.
A	0.55 m	17,00 m <sup>2</sup>	16,00 m
B	-	-	
C	-	-	

Nawierzchnia / Safe surface / Fallschutzbelag / fr		4208E
	Materiał Material Material	Min. wysokość warstwy Min. layer thicknesses Min. Schichtöhe
h<0,6 m	Beton / Concrete / Beton Nawierzchnia bitumiczna / Bituminous surfacing / Bituminöse Oberfläche	
h<1 m	Gleba / Topsoil / Boden Darń / Turf / Grasnarbe	
h<2 m	Kora / Bark / Borke	20÷80 mm
	Wióry / Wood chips / Holzackschnitzel	5÷30 mm
	Piasek / Sand / Sand Żwir / Gravel / Kies	0,25÷8 mm
h<3 m	Kora / Bark / Borke	20÷80 mm
	Wióry / Wood chips / Holzackschnitzel	5÷30 mm
	Piasek / Sand / Sand Żwir / Gravel / Kies	0,25÷8 mm
h<3 m	Nawierzchnia syntetyczna / Synthetic granulates / Synthetische Oberfläche	wg danych producenta acc. to the manufacturer's data nach Angaben des Herstellers

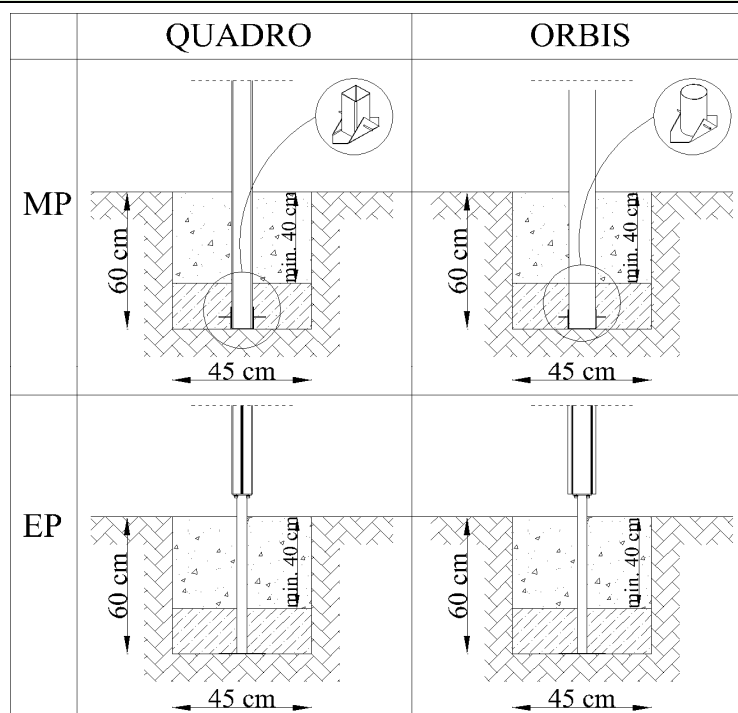

Posadowienie / Foundation / Gründung / Fondation	4208E
--	-------

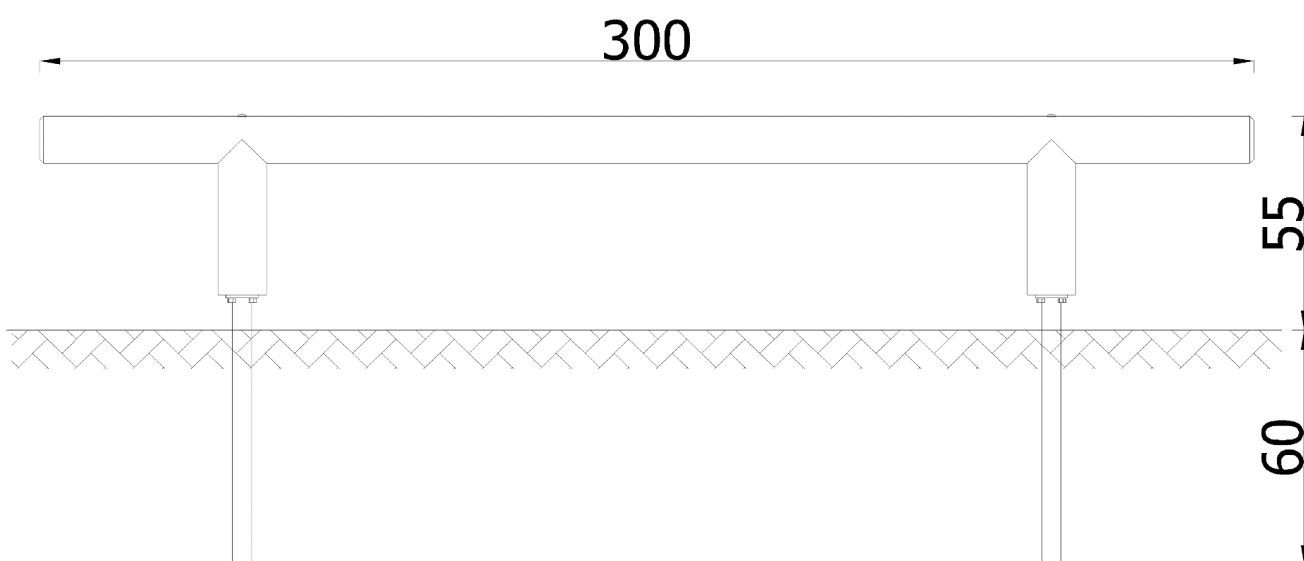

Beton / Concrete / Beton: **C16/20 - 0,1 m<sup>3</sup>**

W celu kontroli fundamentów należy usunąć nawierzchnię bezpieczną / piasek / żwir etc.  
 In order to control the foundations, remove the safe surface (sand, gravel, etc.)  
 Um die Fundamente zu überprüfen, entfernen Sie den Fallschutzbelag: Sand/ Kies etc.

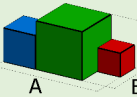
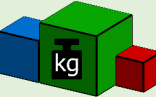
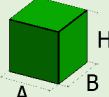

	<p>1,2x3x0,3 (AxBxH) [m]</p>		<p>32 kg</p>		<p>0,12x3x0x12 (AxBxH) [m]</p>		<p>19 kg</p>
---	----------------------------------	---	--------------	---	------------------------------------	---	--------------

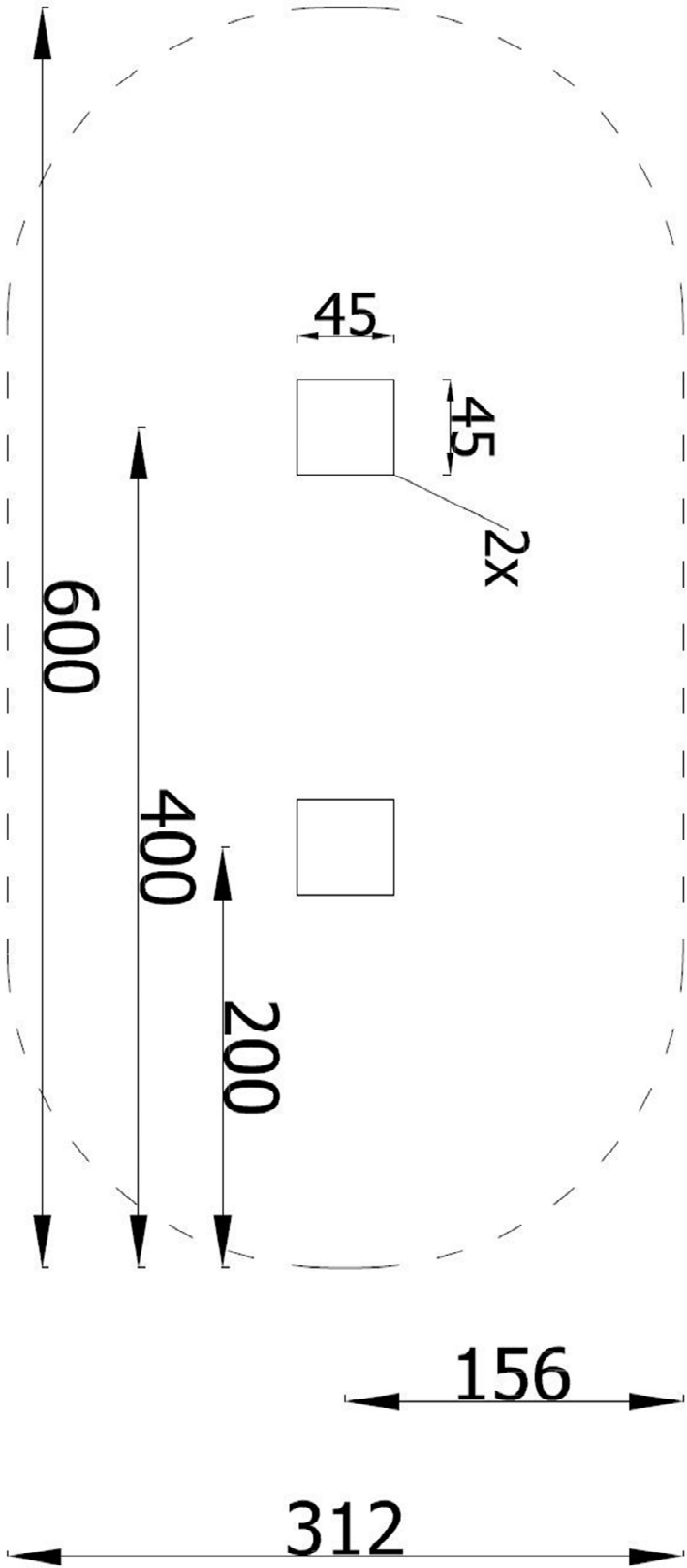

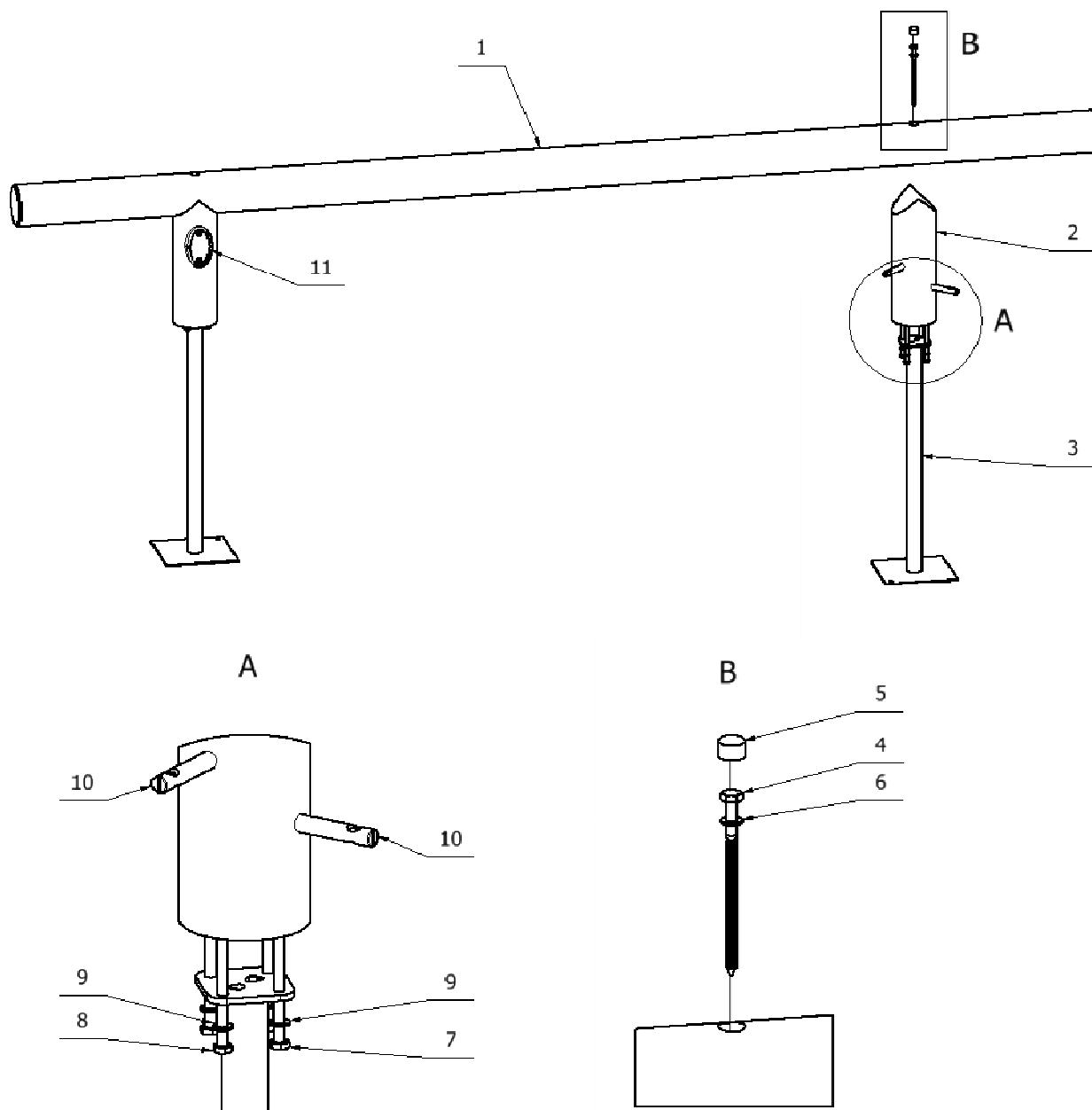

Części zamienne dostępne u producenta. Stosować klej do gwintów w połączeniach śrubowych.  
 Spare parts available from the manufacturer. Use thread glue in screw connections.  
 Ersatzteile beim Hersteller erhältlich. Gewindekleber für Schraubverbindungen verwenden.

11		Tabliczka znamionowa pionowa		8918_002		1	
10		Sworzeń 17 x 115 mm		8942_002		4	
9		Podkładka sprężysta		DIN127_10		8	
8		Śruba z łbem sześciokątnym		ISO4014_M10x200		4	
7		Śruba z łbem sześciokątnym		ISO4014_M10x125		4	
6		Podkładka		ISO7089_10_A2		2	
5		Zaślepka korka		8924_001		2	
4		Wkręt z łbem sześciokątnym		DIN571_10x180		2	
3		Kotwa standardowa		L8806_003		2	
2		Belka 120x390[mm]		O_4208_002		2	
1		Belka fi 120x3000 [mm]		O_4208_001		1	
Lp. Art. Nr.	No. Rep.	Nazwa części Teilename	Part name Nom de la pièce	Nr części Teile-Nr	Part No. Partie No.	Ilość Anzahl	Quantity Nombre

Narzędzia / Tools / Handwerkzeug / Outils

4208E

															
								5 m	30 m						
															
2,5 m				60 cm	100 cm										
															
				7 mm								13 mm	17 mm	19 mm	24 mm
															
13 mm	17 mm	19 mm	24 mm	4 mm	5 mm	6 mm	8 mm	T40				T45			
															