

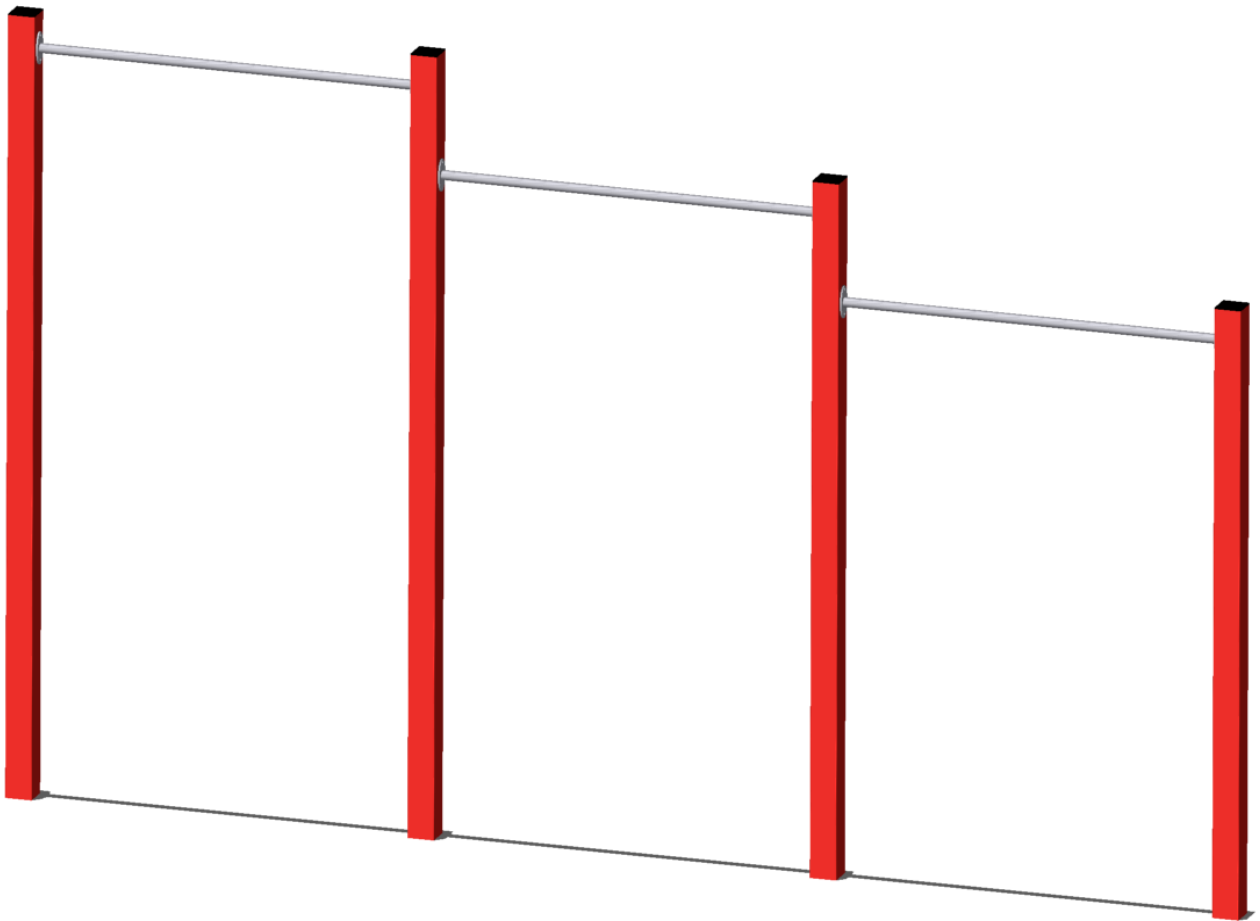

PL	INSTRUKCJA MONTAŻU	Nazwa		Nr kat.	15207
ENG	ASSEMBLY INSTRUCTIONS	Product		Cat. no.	
DEU	MONTAGEANLEITUNG	Name		Art.-Nr.	
FRA	INSTRUCTIONS D'INSTALLATION	Catégorie		Référence.	

15207



Wiek użytkowników Age of users Altersgruppe	Ilość użytkowników Number of users Anzahl der Benutzer Nombre d'utilisateurs	Przeznaczenie urządzenia Purpose of device Bestimmung des Spielgerätes	Zgodność z normą In accordance with the standard Geltende Norm
14 +	3	do zabawy na zewnątrz for outdoor playing zum draußen Spielen	PN-EN 16630:2015
NOVUM Sp. z o.o. Sp. k. ul. Bolesława Chrobrego 1, 12-100 Szczytno		e-mail: biuro@novumedukacja.pl	www.novumedukacja.pl
NOVUM Sp. z o.o. Sp. k. ul. Bolesława Chrobrego 1, 12-100 Szczytno		e-mail: eksport@novumgrom.com	www.novum4kids.com
NOVUM Deutschland GmbH, Schiffgesweg 11, 50259 Pulheim		e-mail: service@novum4kids.de	www.novum4kids.de
NOVUM DIRECT France Centre Commerciale La Samiane 01290 CROTTET		e-mail: contact@novum-direct.fr	www.novum-direct.fr

UWAGA / WARNING / ACHTUNG / ATTENTION:

PL Jeżeli w zestawie występuje zjeżdżalnia, zestaw należy posadowić w taki sposób, aby ślizg zjeżdżalni znajdował się od strony północnej, czyli od strony nienasłonecznionej, aby zapobiegać nadmiernemu nagrzewaniu się ślizgu.

ENG If there is a slide in the set, it should be installed from the north, poorly sunny side to avoid possible hazards (burns) through direct skin contact.

DEU Wenn eine Spielplatzanlage eine Rutsche enthält, sollte diese Anlage so platziert werden, dass die Rutsche sich auf der Nordseite befindet, dh. auf der schattigen Seite, um übermäßige Erwärmung der Rutschbahn zu vermeiden.

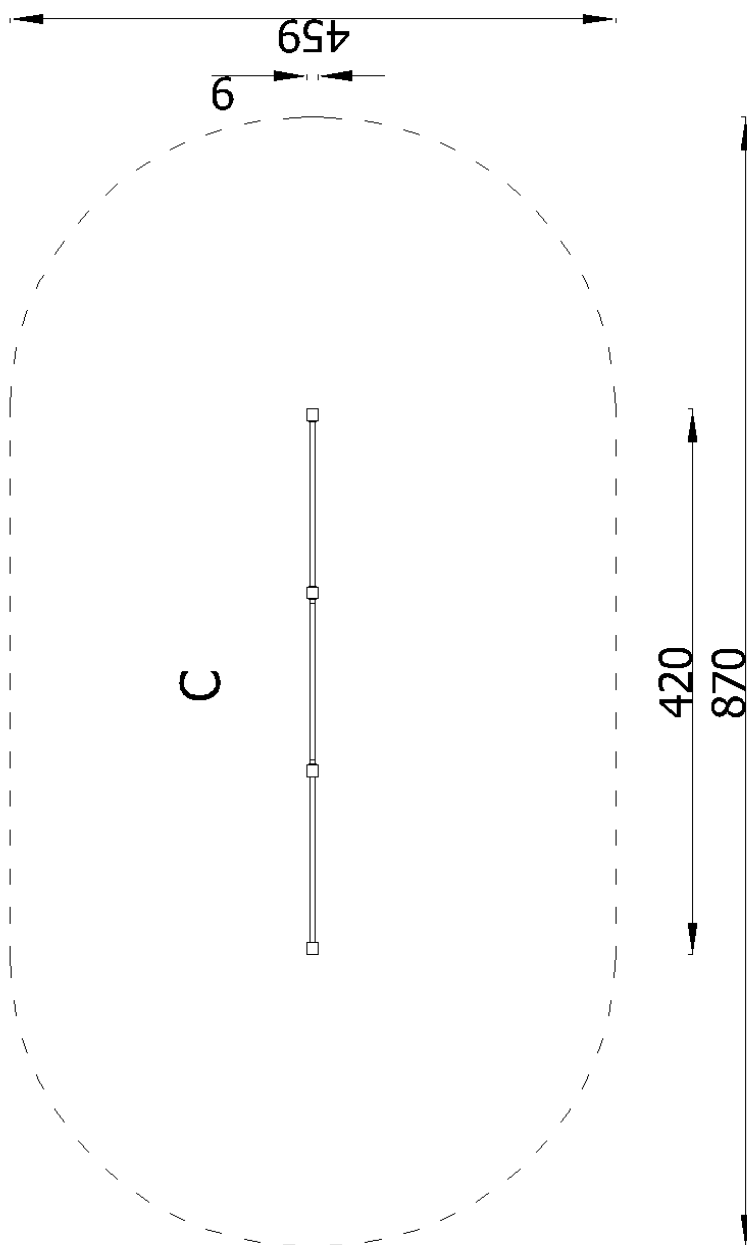

Montaż zgodnie z planem zagospodarowania terenu.
 Installation in accordance with the land development plan.
 Montage gemäß dem Flächennutzungsplan

Bezpieczna nawierzchnia / Safe surface / Safe Oberfläche / Surface sûre

Strefa Zone Zone Zone	Max. wysokość upadku Max. fall height Max. Fallhöhe Max. hauteur de chute	Pole powierzchni Surface area Fläche Surface	Obwód strefy bezpiecz. Perimeter security zone Umkreis der Fallschutzfläche Zone de périmètre de sé.
A	2,60 m	35,60 m ²	22,70 m
B	-	-	
C	-	-	

Nawierzchnia / Safe surface / Fallschutzbelag / fr			15207
	Materiał Material Material	Min. wysokość warstwy Min. layer thicknesses Min. Schichtöhe	
h<0,6 m	Beton / Concrete / Beton Nawierzchnia bitumiczna / Bituminous surfacing / Bituminöse Oberfläche		
h<1 m	Gleba / Topsoil / Boden Darıń / Turf / Grasnarbe		
h<2 m	Kora / Bark / Borke	20÷80 mm	300
	Wióry / Wood chips / Holz hackschnitzel	5÷30 mm	
	Piasek / Sand / Sand Żwir / Gravel / Kies	0,25÷8 mm	
h<3 m	Kora / Bark / Borke	20÷80 mm	400
	Wióry / Wood chips / Holz hackschnitzel	5÷30 mm	
	Piasek / Sand / Sand Żwir / Gravel / Kies	0,25÷8 mm	
h<3 m	Nawierzchnia syntetyczna / Synthetic granulates / Synthetische Oberfläche	wg danych producenta acc. to the manufacturer's data nach Angaben des Herstellers	

Posadowienie / Foundation / Gründung / Fondation	15207
--	-------

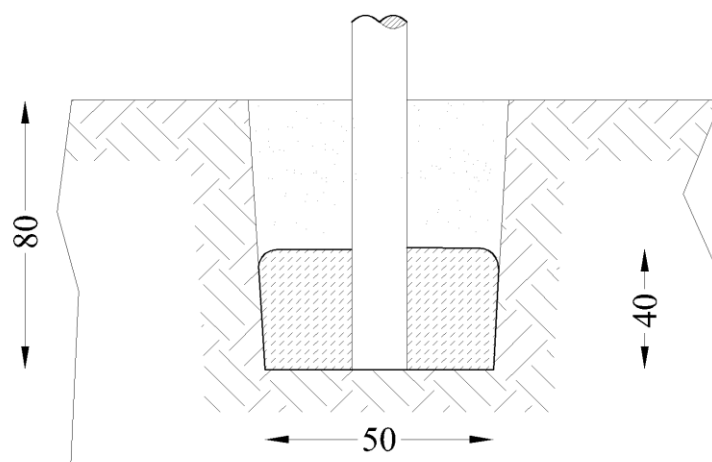

Beton / Concrete / Beton: **C16/20** - **0,31 m³**

W celu kontroli fundamentów należy usunąć nawierzchnię bezpieczną / piasek / żwir etc.

In order to control the foundations, remove the safe surface (sand, gravel, etc.)

Um die Fundamente zu überprüfen, entfernen Sie den Fallschutzbelag: Sand/ Kies etc.

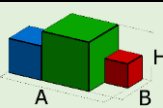
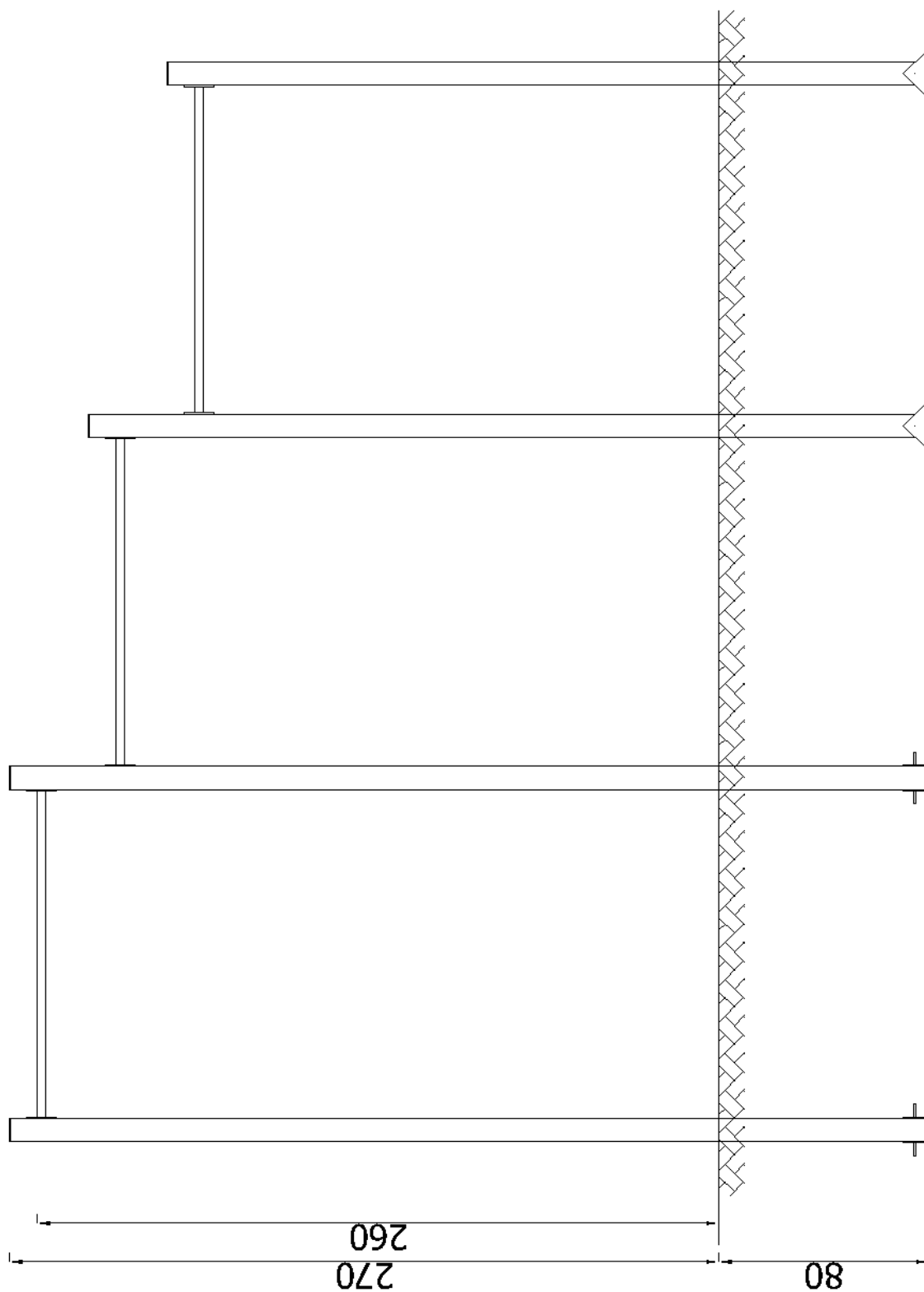

4,2x0,9x2,7
(AxBxH) [m]

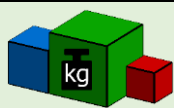

- kg

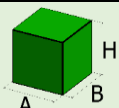

(AxBxH) [m]



0 kg

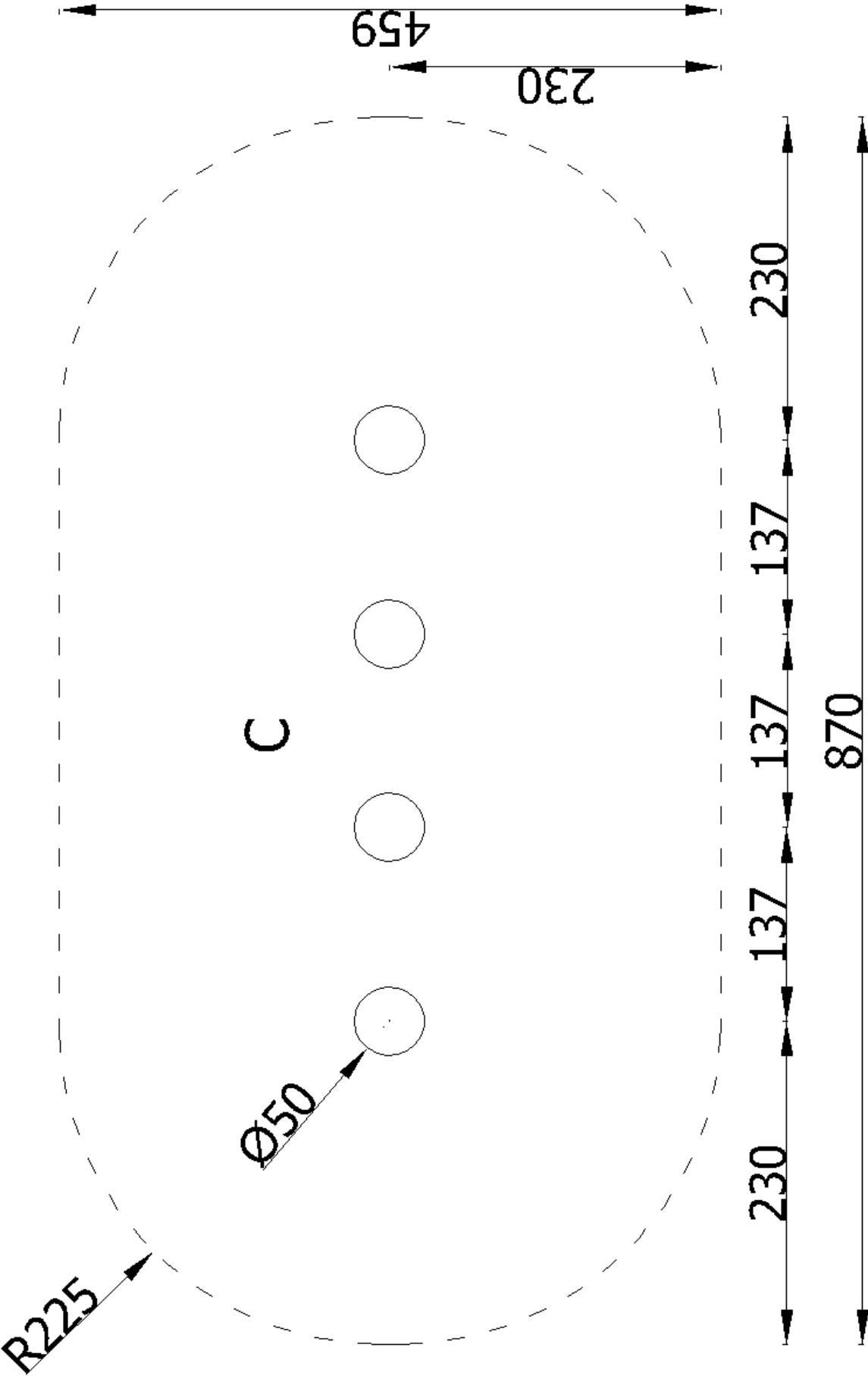

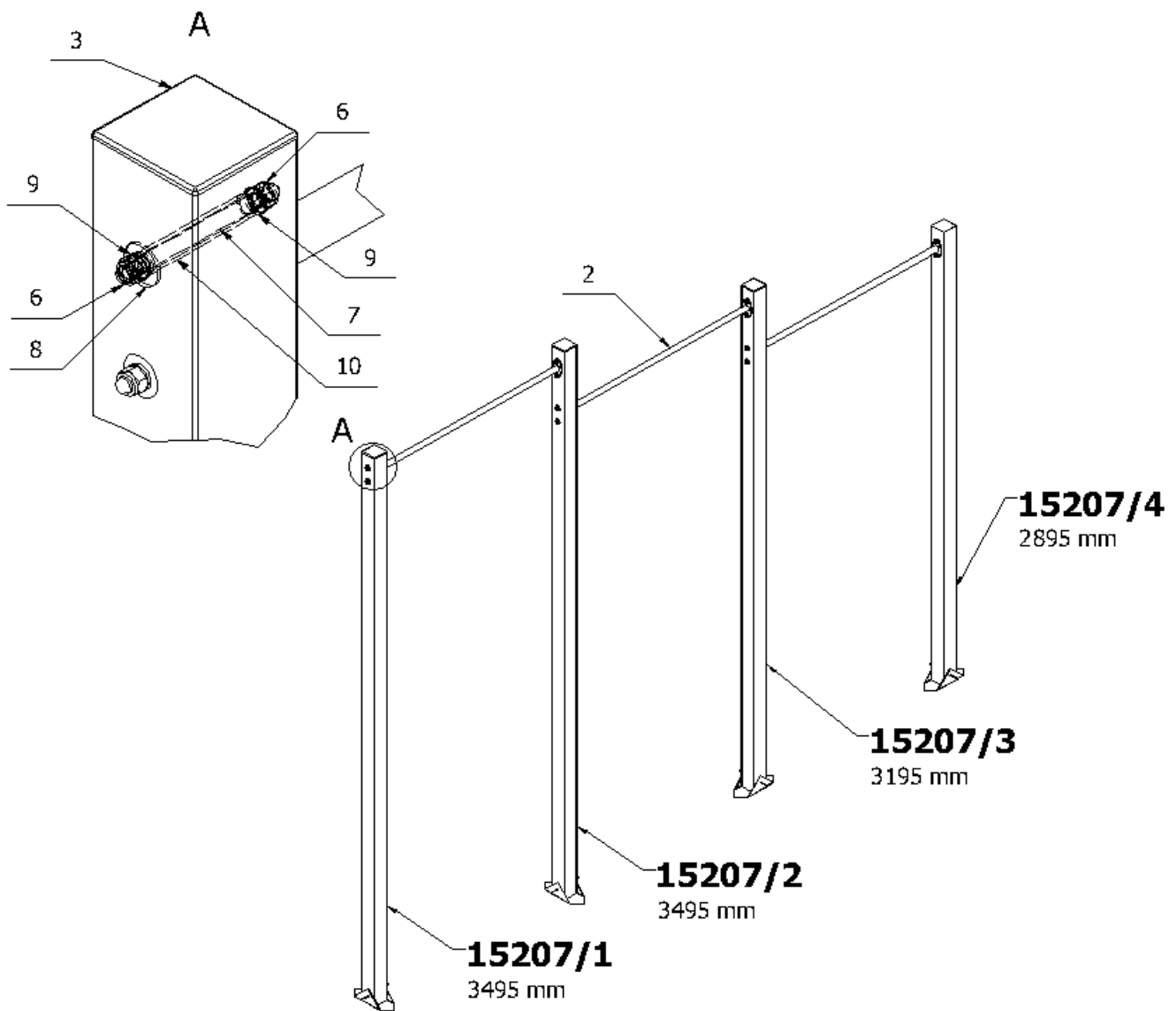



10	Tuleja 16x2x89mm	R_8813_008_A2	12	1.4301	0,063	
9	Podkładka sprężysta	DIN127_10_A2	24	A2	0,003	
8	Podkładka szeroka	ISO7093_10_A2	12	A2	0,012	
7	Szpilka gwintowana M10x130	8816_130_A2	12	A2	0,010	
6	Nakrętka kołpakowa	DIN986_M10_A2	24	A2	0,018	
5	Pręt 6x200 mm	8850_002	4	Stal	0,044	
4	Błacha 3x200x200	B_8802_027	4	S235JR	0,943	
3	Zaślepka kwadratowa 90x90	8912_212	4	PE	0,049	
2	Drażek 1280	L27197_001	3		4,164	
1	Komplet słupów wierconych 15207	15207/1_15207/4	1			
Nr.	Nazwa	Nr Rys./Normy	Ilość	Materiał	Masa	Uwagi

Części zamienne dostępne u producenta. Stosować klej do gwintów w połączeniach śrubowych.
 Spare parts available from the manufacturer. Use thread glue in screw connections.
 Ersatzteile beim Hersteller erhältlich. Gewindekleber für Schraubverbindungen verwenden.

Narzędzia / Tools / Handwerkzeug / Outils

15207

															
								5 m	30 m						
															
2,5 m				60 cm	100 cm										
															
				7 mm								13 mm	17 mm	19 mm	24 mm
															
13 mm	17 mm	19 mm	24 mm	4 mm	5 mm	6 mm	8 mm	T40				T45			
															

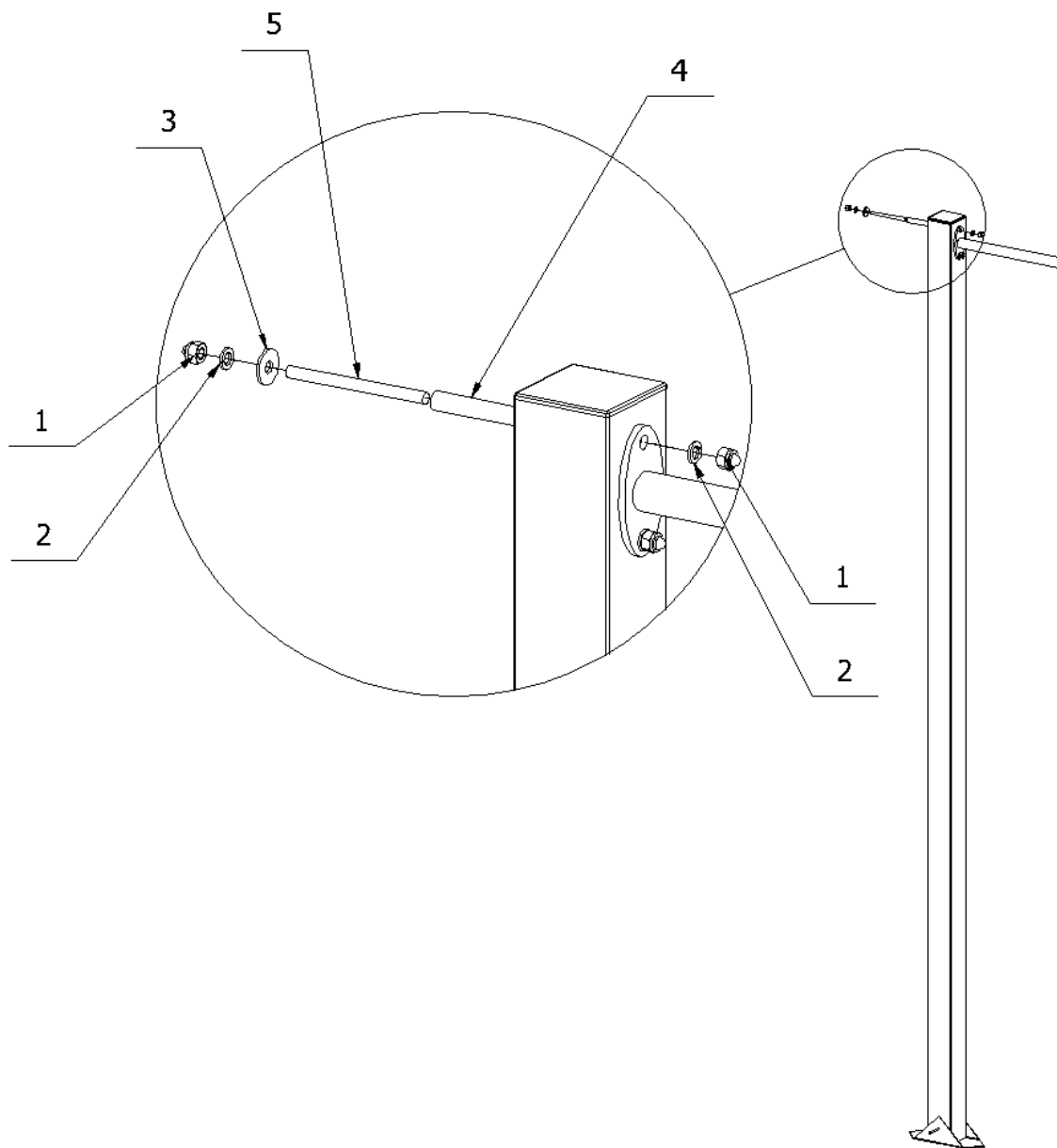

5	2	8816_130_A2
4	2	R_8813_003
3	2	ISO7093_10_A2
2	4	DIN127_10_A2
1	4	DIN986_M10_A2
Nr.	Il.	Nr Rys./Normy