



PL	INSTRUKCJA MONTAŻU	Nazwa	Tunel Terra z kotwami	Nr kat.	58212PZ
ENG	ASSEMBLY INSTRUCTIONS	Product	Terra Tunnel with Anchors	Cat. no.	
DEU	MONTAGEANLEITUNG	Name	Terra- Tunnel mit Bodenankern	Art.-Nr.	

58212PZ



Wiek użytkowników Age of users Altersgruppe	Ilość użytkowników Number of users Anzahl der Benutzer	Przeznaczenie urządzenia Purpose of device Bestimmung des Spielgerätes	Zgodność z normą In accordance with the standard Geltende Norm
1-7	2	do zabawy na zewnątrz for outdoor playing zum draußen Spielen	PN-EN 1176-1+A1:2024-03
NOVUM Sp. z o.o. ul. Gnieźnieńska 2a, 12-100 Szczytno		e-mail: kontakt@novum4kids.pl e-mail: export@novum4kids.com	www.novum4kids.pl www.novum4kids.com

UWAGA / WARNING / ACHTUNG:

PL Jeżeli w zestawie występuje zjeżdżalnia, zestaw należy posadowić w taki sposób, aby ślizg zjeżdżalni znajdował się od strony północnej, czyli od strony nienasłonecznionej, aby zapobiegać nadmiernemu nagrzewaniu się ślizgu.

ENG If there is a slide in the set, it should be installed from the north, poorly sunny side to avoid possible hazards (burns) through direct skin contact.

DEU Wenn eine Spielplatzanlage eine Rutsche enthält, sollte diese Anlage so platziert werden, dass die Rutsche sich auf der Nordseite befindet, dh. auf der schattigen Seite, um übermäßige Erwärmung der Rutschbahn zu vermeiden.

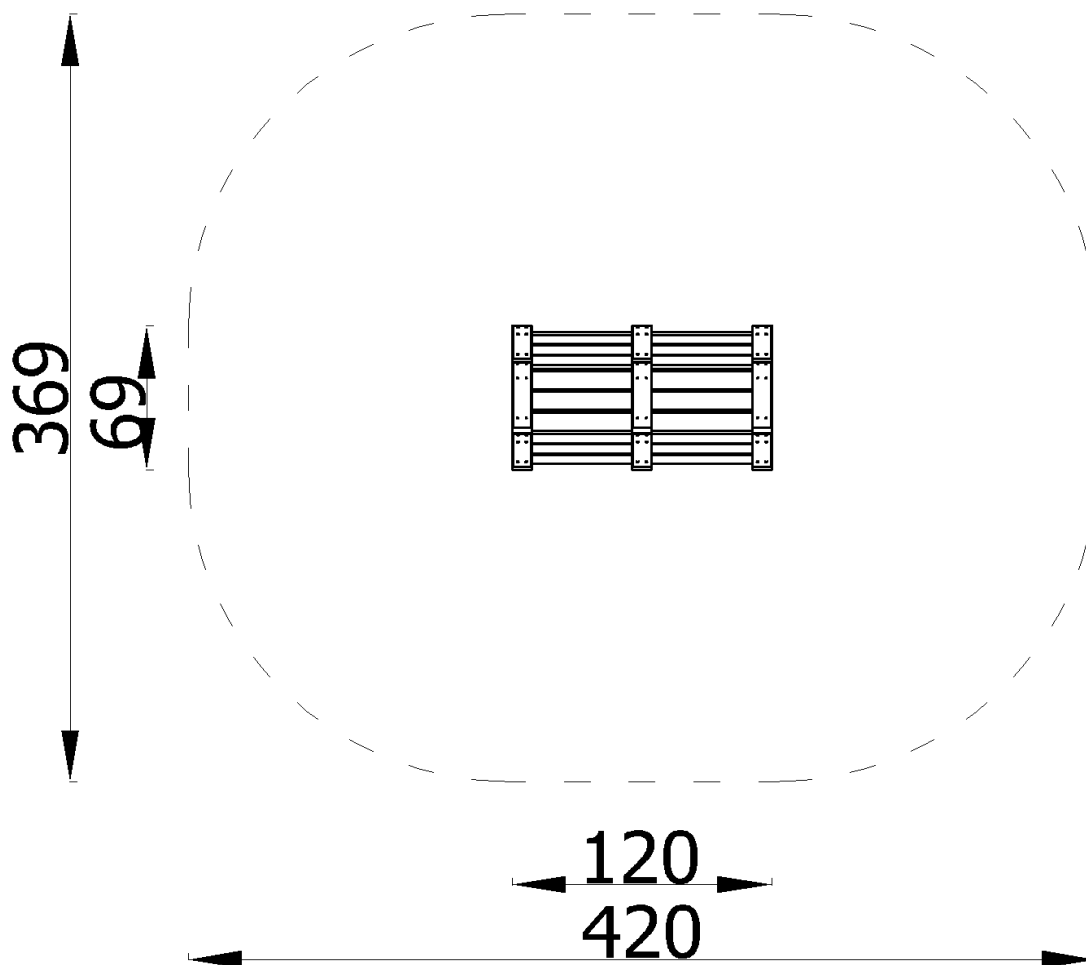

Montaż zgodnie z planem zagospodarowania terenu.
 Installation in accordance with the land development plan.
 Montage gemäß dem Flächennutzungsplan

Bezpieczna nawierzchnia / Safe surface / Safe Oberfläche

Strefa Zone Zone	Max. wysokość upadku Max. fall height Max. Fallhöhe	Pole powierzchni Surface area Fläche	Obwód strefy bezpiecz. Perimeter security zone Umkreis der Fallschutzfläche
A	0,00 m	13,60 m ²	13,20 m
B	-	-	
C	-	-	

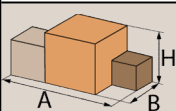
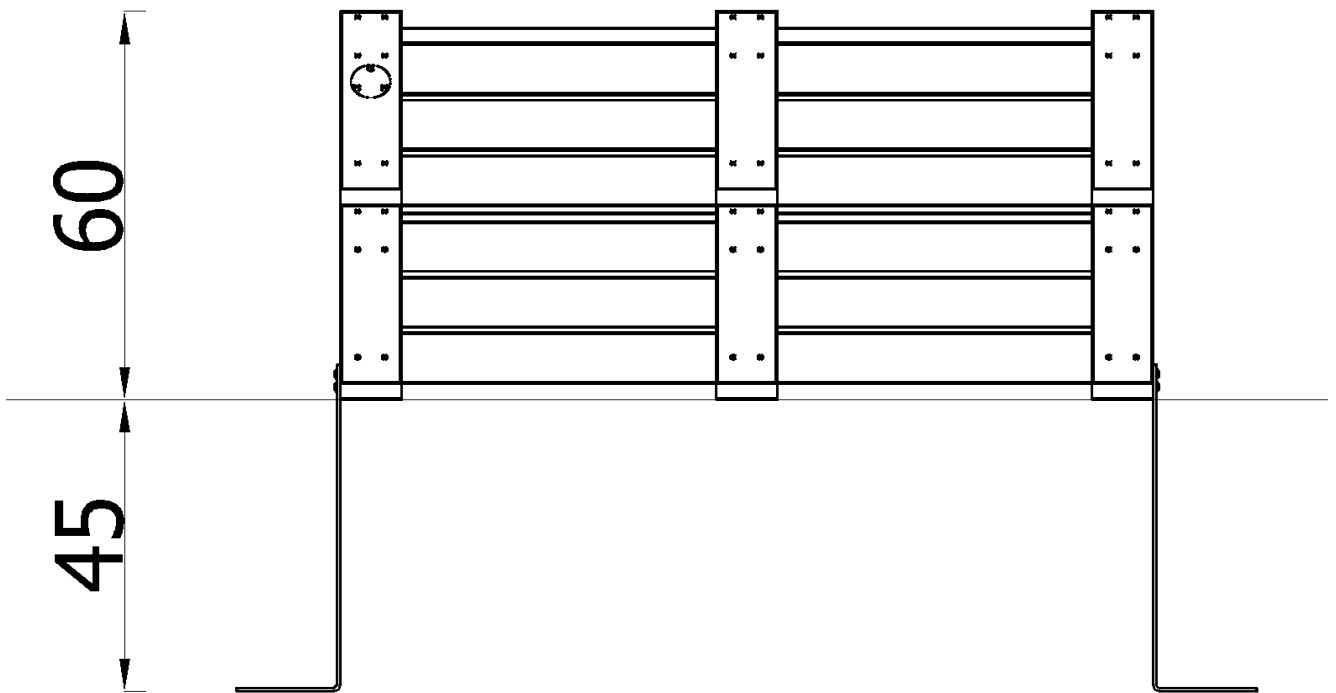

1,2x0,6x0,69
(AxBxH) [m]



38 kg

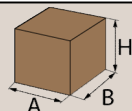

1,2x0,36x0,05
(AxBxH) [m]



6 kg

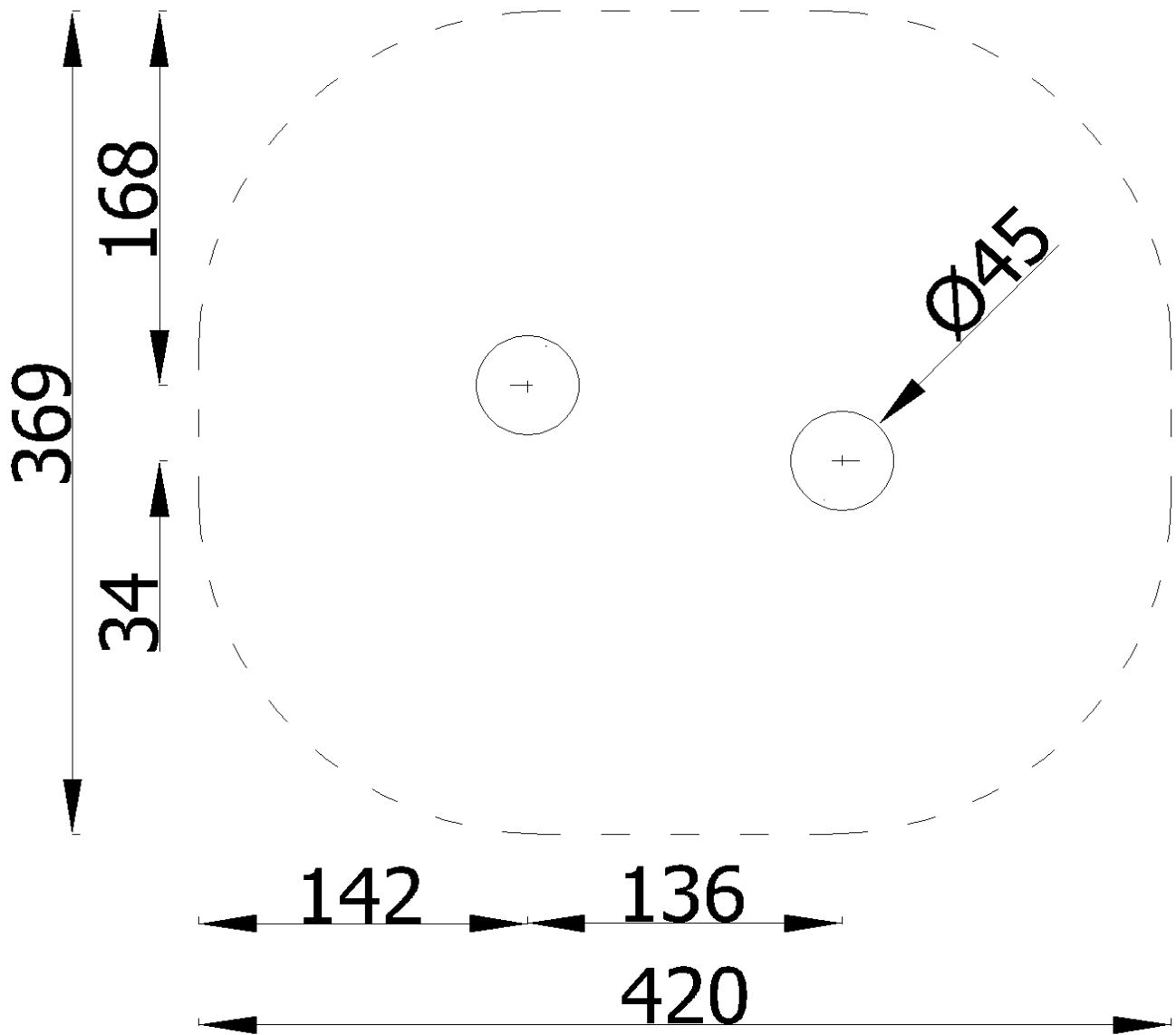

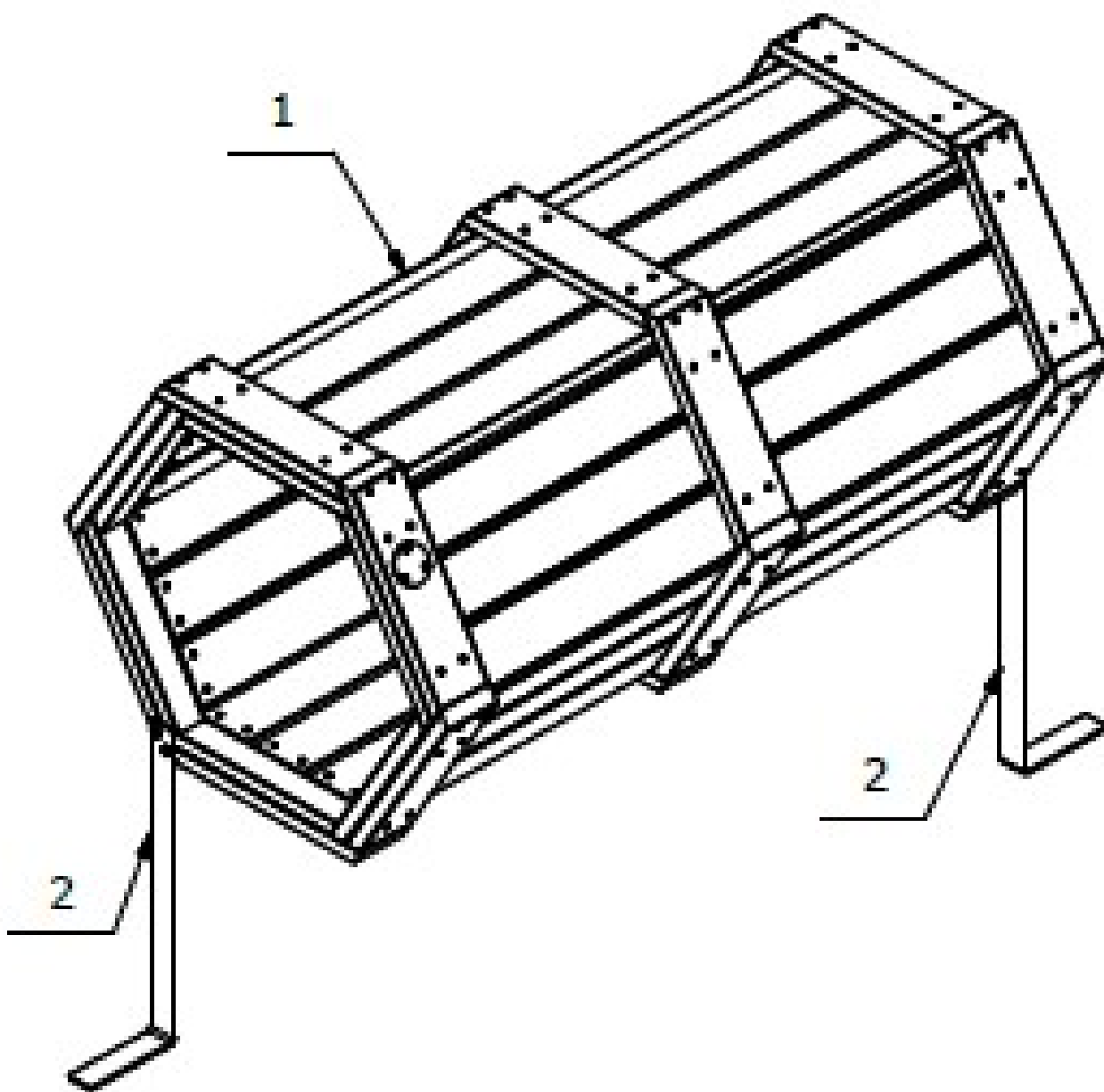

Części zamienne dostępne u producenta.
Stosować klej do gwintów w połączeniach śrubowych.







Spare parts available from the manufacturer.
Use thread glue in screw connections.

Ersatzteile beim Hersteller erhältlich.
Gewindekleber für Schraubverbindungen verwenden.

3		58212-2		1
2		B_58600_001		2
1		58212-1		1
Lp.		Nr części		Ilość
No.	Art. Nr.	Part No.	Teile-Nr	Quantity Anzahl

Narzędzia / Tools / Handwerkzeug

58212PZ

															
								5 m	30 m						
															
2,5 m				60 cm	100 cm										
															
				7 mm								13 mm	17 mm	19 mm	24 mm
															
13 mm	17 mm	19 mm	24 mm	4 mm	5 mm	6 mm	8 mm	T40				T45			
															

58212_001	2
8905_463_5x70_A2	6
Nr Rys./Normy	Ilość

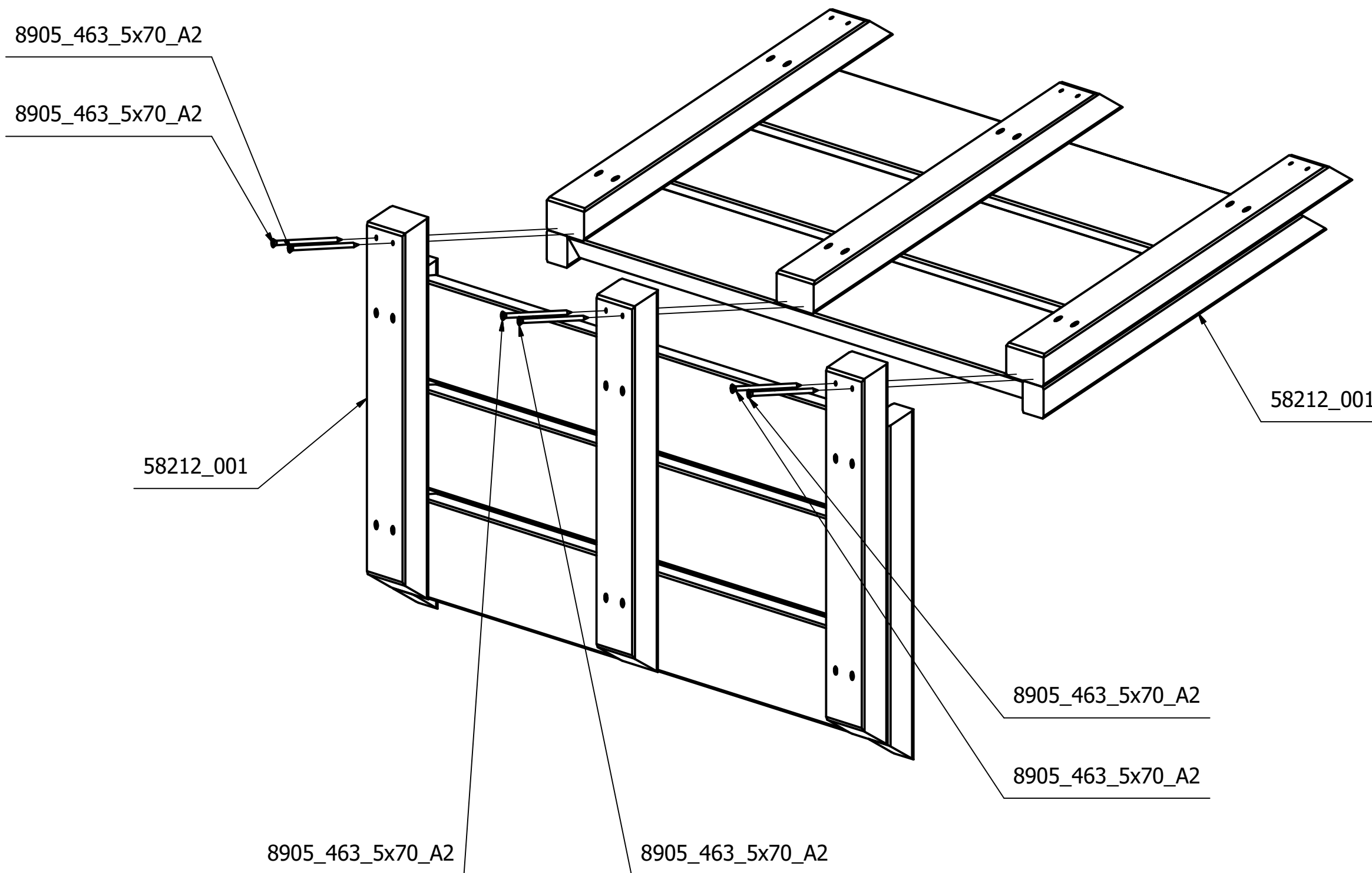

58212_001	3
8905_463_5x70_A2	6
Nr Rys./Normy	Ilość

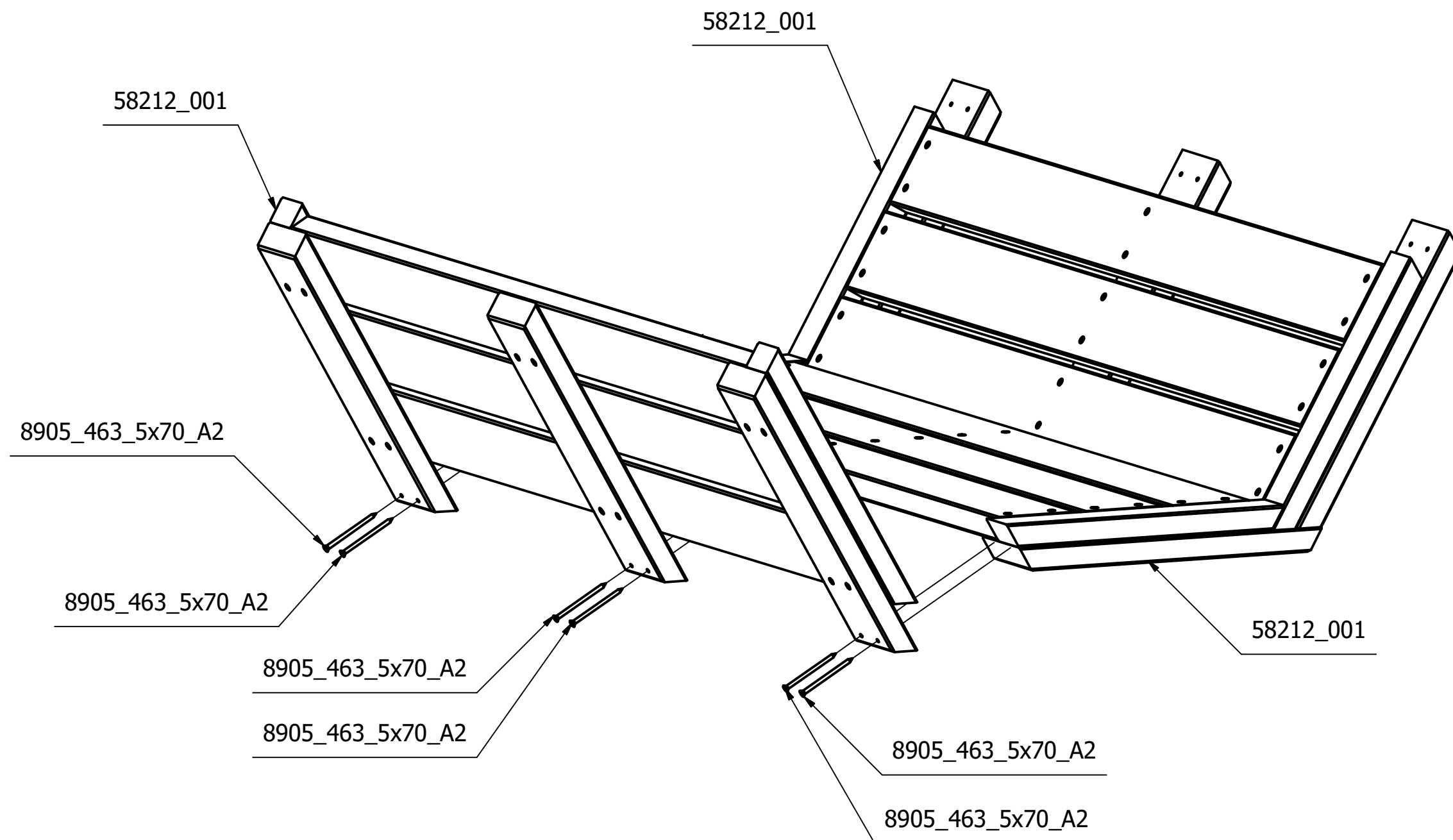

58212_001	4
8905_463_5x70_A2	6
Nr Rys./Normy	Ilość

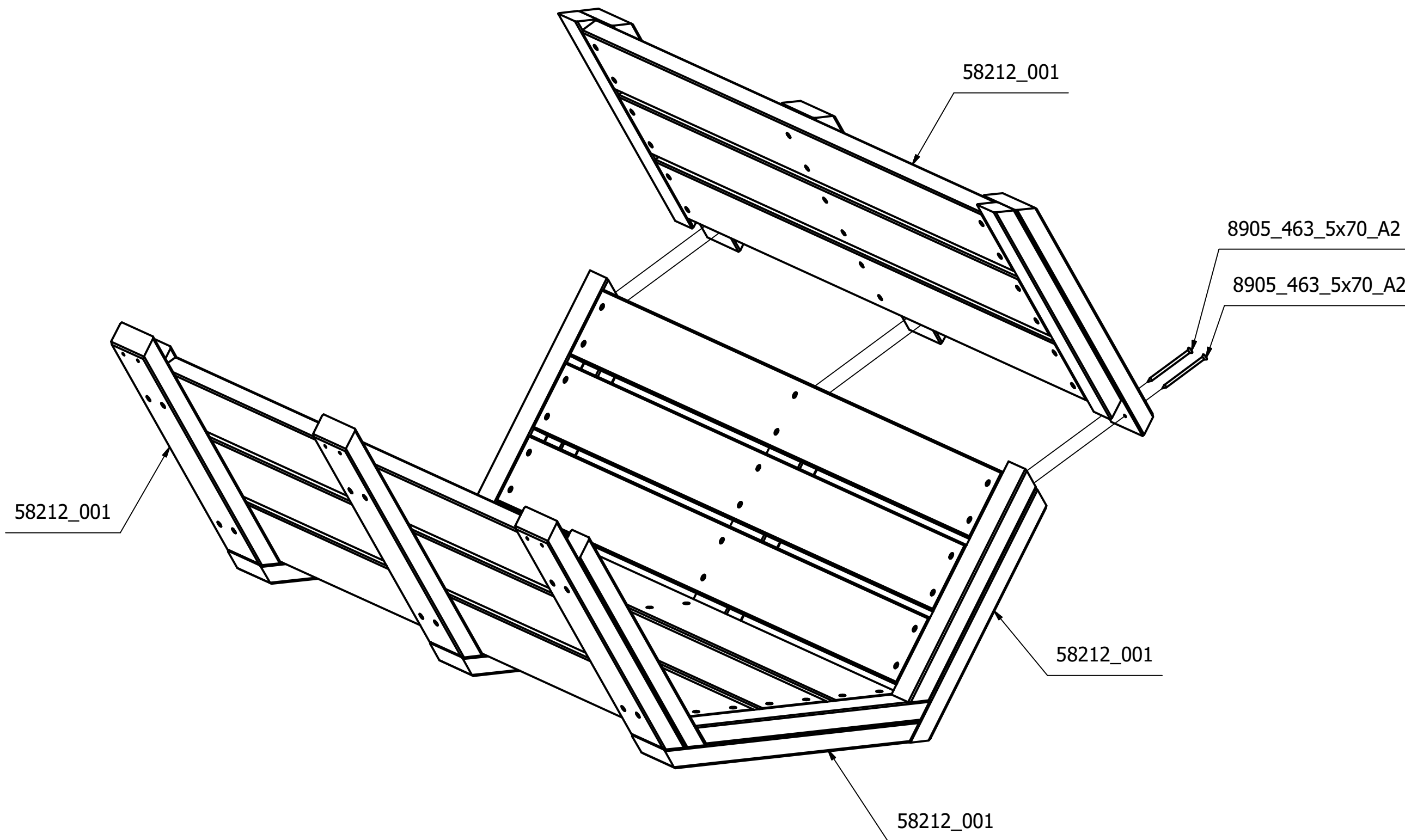

58212_001	5
8905_463_5x70_A2	6
Nr Rys./Normy	Ilość

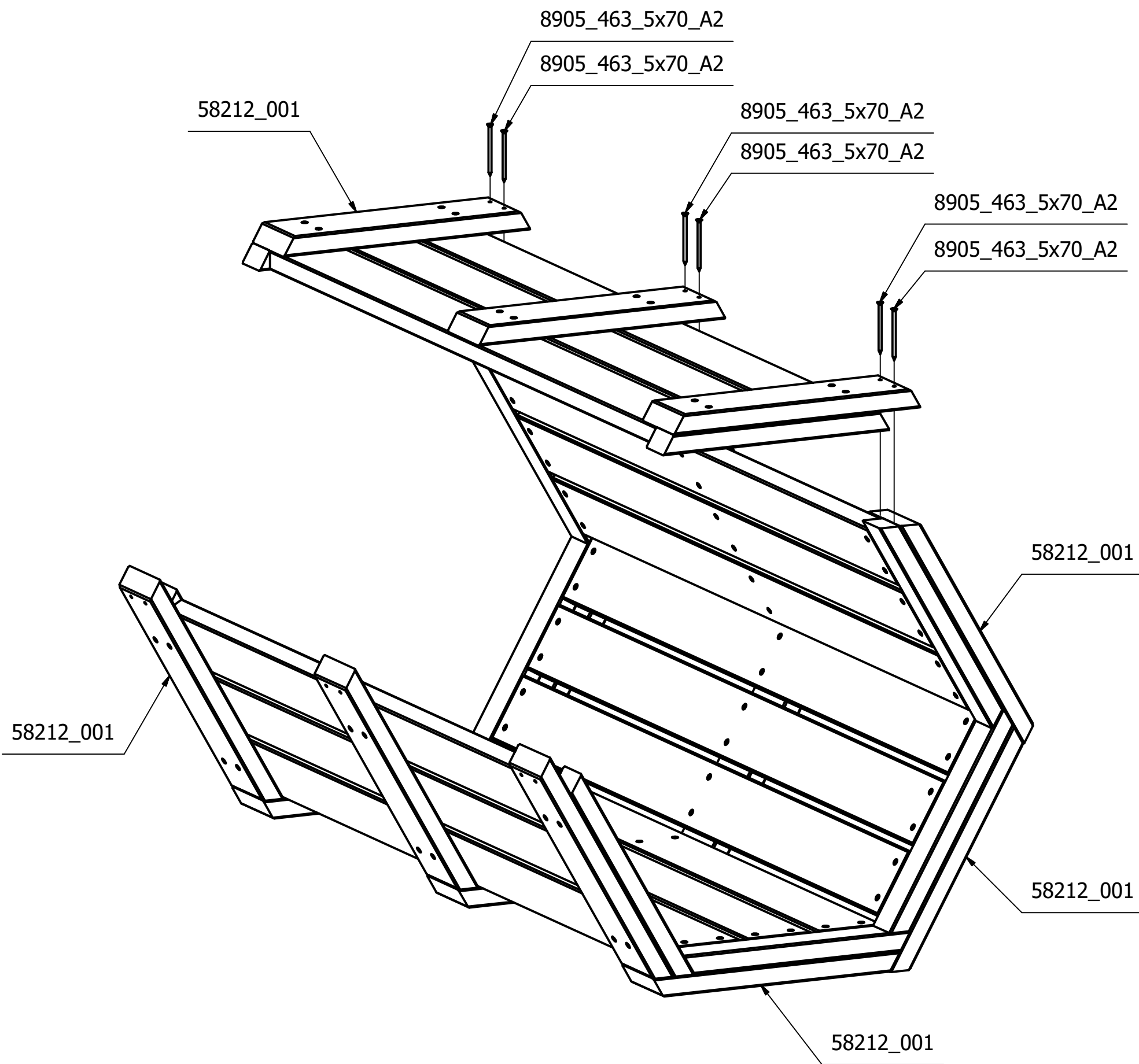

58212_001	6
8905_463_5x70_A2	12
Nr Rys./Normy	Ilość

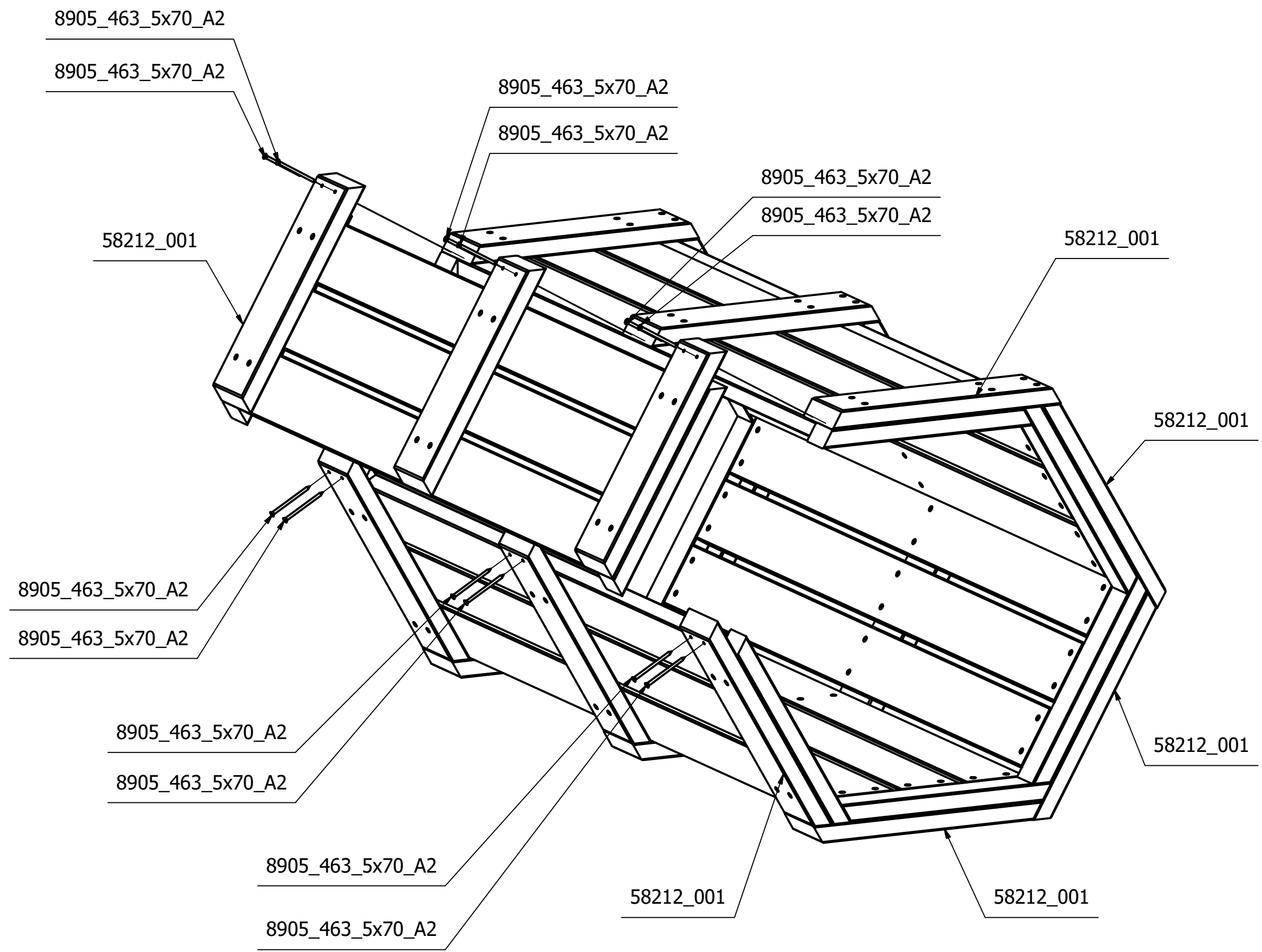

8905_501_4x16_A2	3
8918_003	1
58212-1	1
Nr Rys./Normy	Ilość

8905_501_4x16_A2

8918_003

8905_501_4x16_A2

8905_501_4x16_A2

58212-1

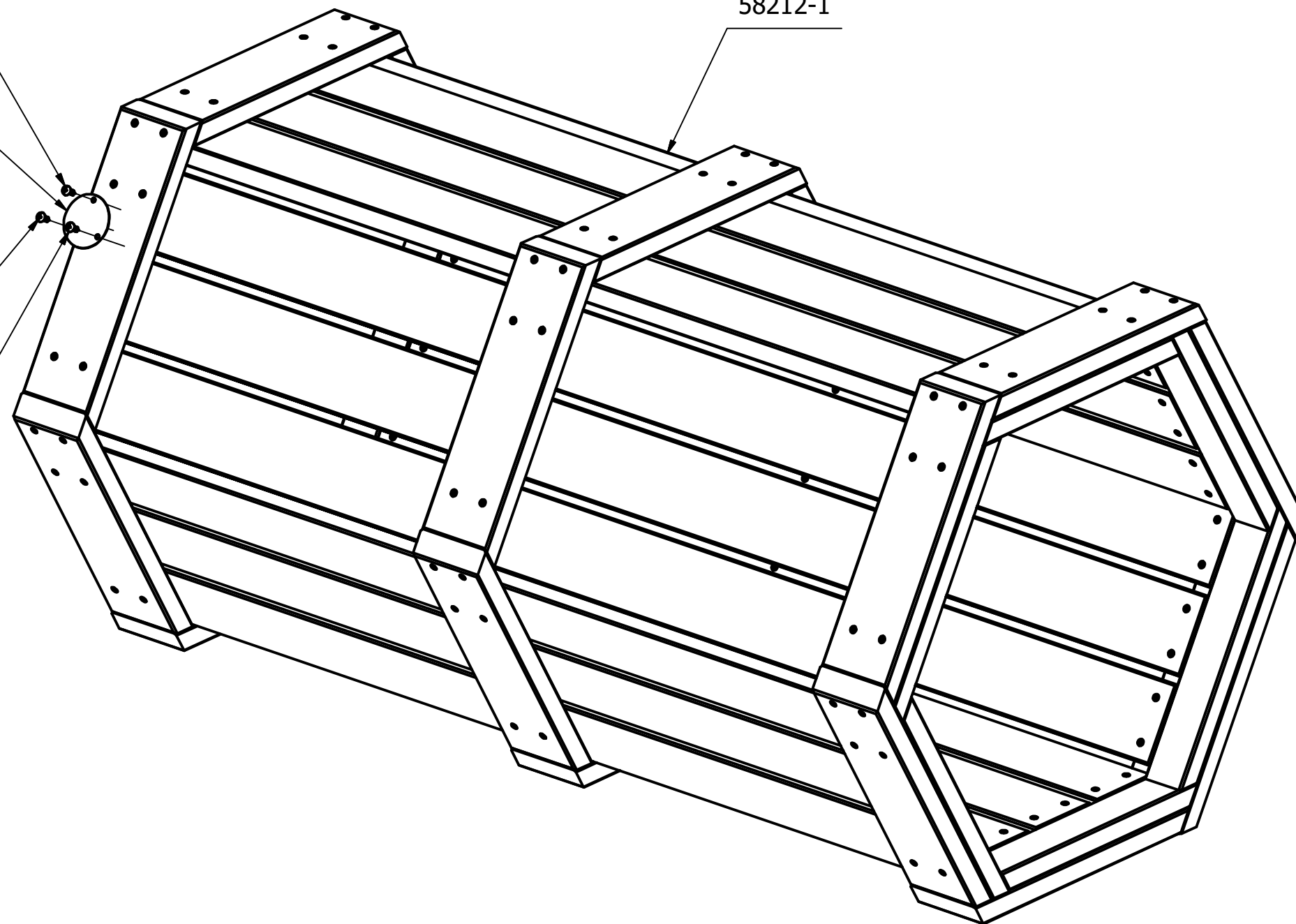

8905_009_5x30_A2	4
B_58600_001	2
58212-1	1
Nr Rys./Normy	Ilość

