



FIX
STREET
FURNITURE

Product Passport:

Planter Line FB-02

Certificate of Conformity: No. UA.10210.01906-25

Date of Issue: June 07, 2025



Visit www.fixunion.com.ua for more information.
Specifications are subject to change without notice. ©2025 Fix Union

Manufacturer: LLC "FIX Production and project union"

Website: fixunion.com.ua

Purpose of this Document

This document provides a general description, information on the intended use of the product, maintenance guidelines, minor repairs, and the manufacturer's warranty.

It applies to various modifications of the product.

The manufacturer reserves the right to make changes to the product's design aimed at improving its performance or updating its appearance. Such modifications may not be reflected in this document, but the document remains applicable to the modified versions.

Planter Line FB-02

Description

The **LN FB-02** planter is designed to integrate greenery into urban and semi-public environments while maintaining a clean, architectural look. Its square, visually balanced proportions and vertical wooden cladding make it ideal for use in parks, pedestrian streets, terraces, and commercial outdoor areas. The planter accommodates small trees, shrubs, flowers, or seasonal compositions and includes a removable internal planting insert.

1. Main technical data and specifications

- Length: 1000 mm
- Width: 1000 mm
- Height: 890 mm

Materials:

Metal: Steel

Metal treatment:

All components undergo anti-corrosion protection through hot-dip galvanizing, in accordance with the EN ISO 1461 standard.

The zinc coating requires no maintenance or monitoring, and has a service life of up to 15 years. After galvanizing, optional powder coating in any RAL color is available upon customer request.

Wood: Solid timber – larch / oak / ash

The wood is used in solid form, with joints and lamination applied only in design-specified areas.

Wood Treatment:

Oil-based finish using linseed oil with a specified color tone.

The coating complies with hygiene standards and is safe for use and direct contact with skin.

Coating Features:

Wood is a natural material that is affected by weather conditions and aging. As a result, it may deform along its length, develop cracks, or change color over time. These changes do not affect the structural integrity of the wood.

As previously mentioned, the wood is treated with a natural oil-based coating made from linseed oil and tinted with a pigment matching the customer's chosen color.

This finish complies with hygiene standards, does not cause allergic reactions, and is safe for contact with skin.

The coating requires scheduled maintenance: the first treatment should be performed six months after installation, and then once a year thereafter.

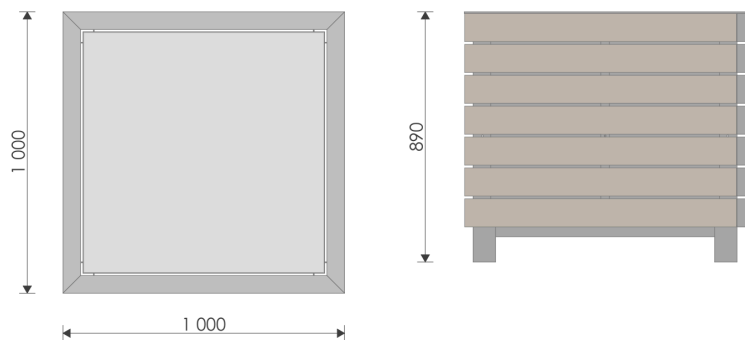

Mounting method: free-standing.

Inner Planting Insert

The **Line FB-02** is equipped with a **removable galvanized metal insert** designed for direct planting or for housing a pre-potted plant. This internal container is:

- **Corrosion-resistant** (hot-dip galvanized or powder-coated steel)
- **Fully detachable**, allowing easy maintenance or seasonal replanting
- **Adaptable** for different climatic conditions:
 - Can be **insulated** from the inside with rigid foam or other materials to protect plant roots from freezing or overheating
 - Can be **lined with geotextile** for improved water retention and soil stability
 - Can include a **drainage layer** (gravel, expanded clay) depending on planting needs

This flexible insert design ensures healthy plant growth and protects the structural outer casing from direct contact with moisture or soil, extending the planter's lifespan.

2. Expected Durability

- **Metal frame:** up to 15 years (with anti-corrosion protection)
- **Wooden elements:** up to 8 years with regular maintenance
- **Paint/Finish:** depends on usage intensity; annual inspection recommended
- **Overall product lifespan:** 8 years
- **Warranty period:** 5 years

3. Regular Maintenance

Component	Frequency	Work Description	Notes
Wood	Once a year	Cleaning, sanding, applying a new layer of oil/varnish	After winter or intense sun exposure
Metal	Once a year	Inspection of galvanizing/paint, localized coating repair	Especially in coastal areas
Fasteners	Once a year	Check bolts/screws for tightness	Retighten or replace if needed
Cleaning	Every 6 months	Gentle washing without abrasives	Do not use acidic cleaning agents

4. Response to Damage or Vandalism

- Record the damage and restrict user access
- Contact the manufacturer or an authorized service provider
- Replace only with original parts
- Minor repairs must be carried out by authorized specialists only

5. Operating Conditions

- The product must be installed in accordance with the provided instructions
- Use is prohibited during icy conditions, storms, hail, etc.
- Do not exceed the maximum load capacity

6. Warranty Limitations

- Vandalism, mechanical damage, natural disasters
- Installation or repair by unauthorized personnel
- Use of the product not in accordance with its intended purpose
- Wear and tear over time (e.g., scratches, cracks, fading)

7. Compliance with Standards



- Complies with EN ISO 1461 standard (hot-dip galvanizing)
- Certificate of Conformity: No. UA.1O210.01906-2 issued June 07, 2025
- Additional certifications: ISO 9001, ISO 14001

Contact information

Bichna Franka str, 14 Zymna Voda village, Lviv region UKRAINE
+38 073 225 03 53
Visit www.fixunion.com.ua