

BENITO -Play

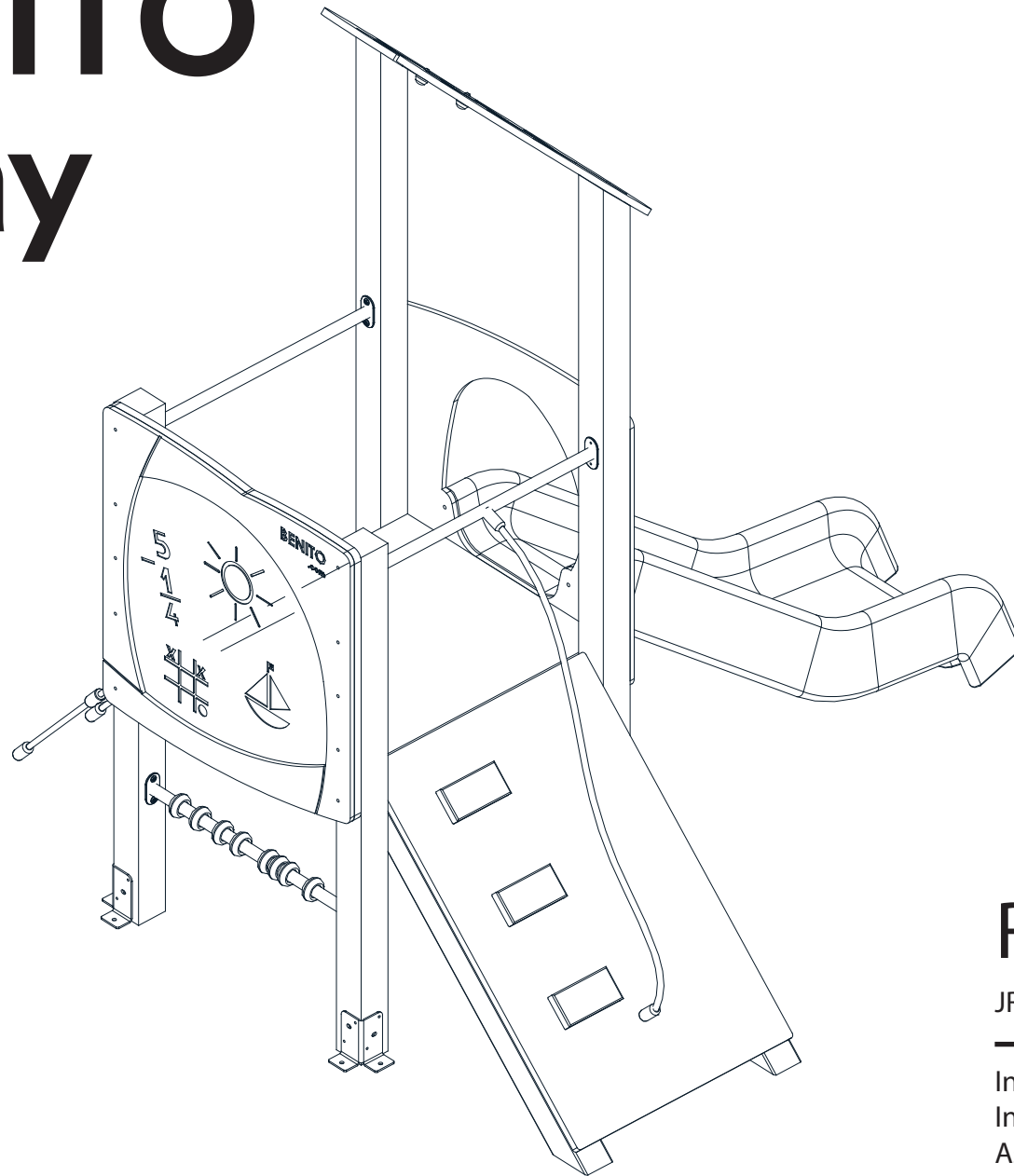

Reb 2

JREB02R

Instrucciones de montaje
Instructions de montage
Assembly instructions

HIC Altura de caída libre
 Free height of fall
 Hauteur de chute libre

S Área de impacto
 Impact zone zone d'impact
 Hauteur de chute libre

Area de seguridad:
 Safe area:
 Aire de sécurité:

Altura max. caída:
 Maximum drop high:
 Hauteur maximale de chute:

Nº usuarios:
 Number of users:
 Nombre d'utilisateurs:

Edad:
 Age:
 Age:

23,20 m²

900 mm

10

3 - 10

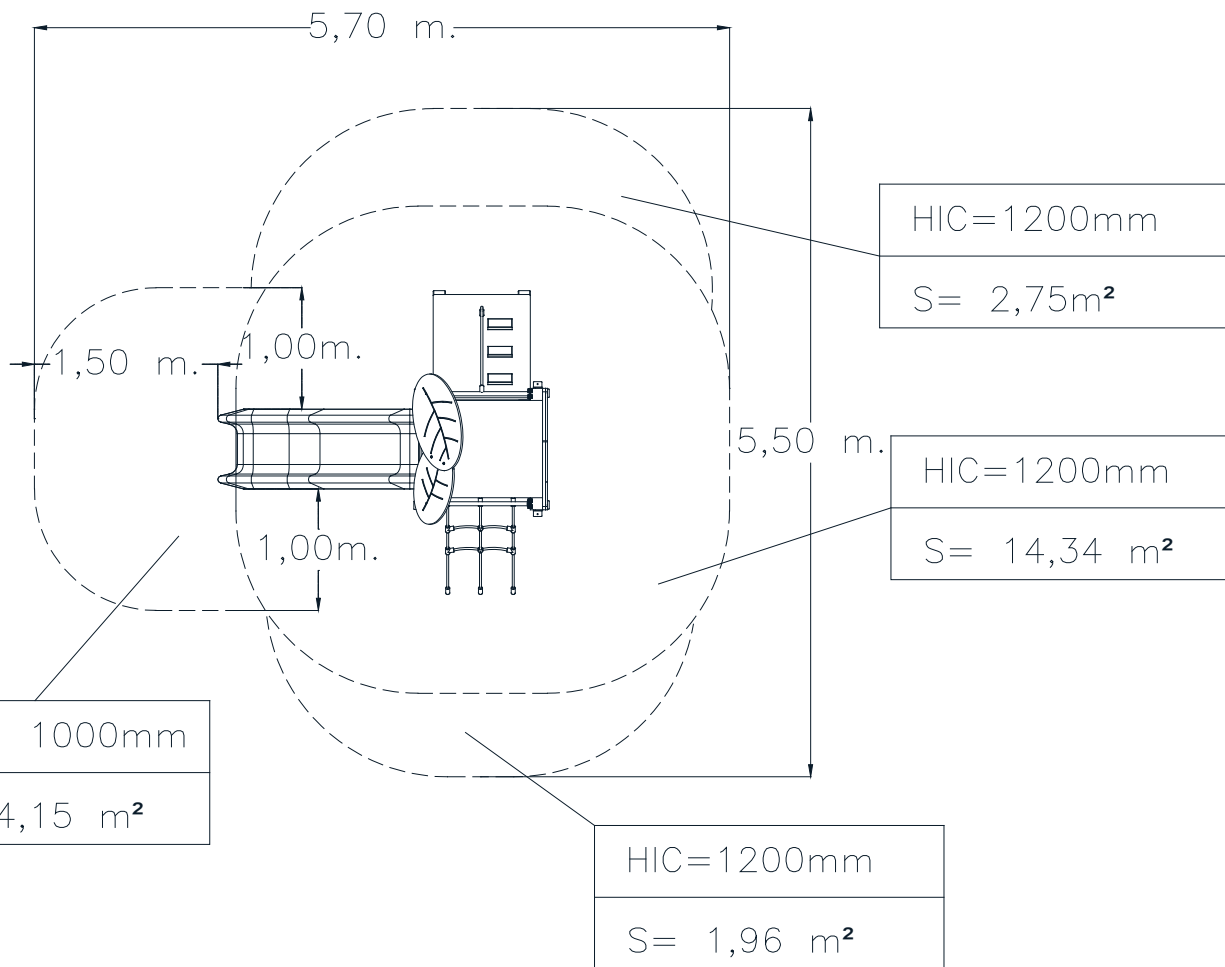

Revestimiento del suelo según norma EN - 1176-1:2017
 Floor covering according to standard EN - 1176-1:2017
 Revêtement de sol selon la norme EN - 1176-1:2017

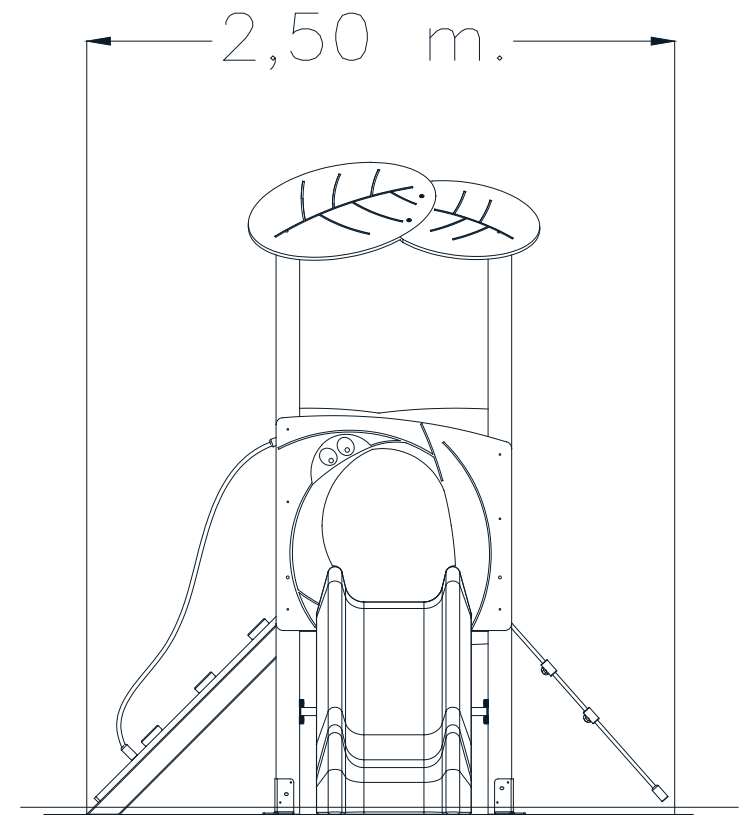
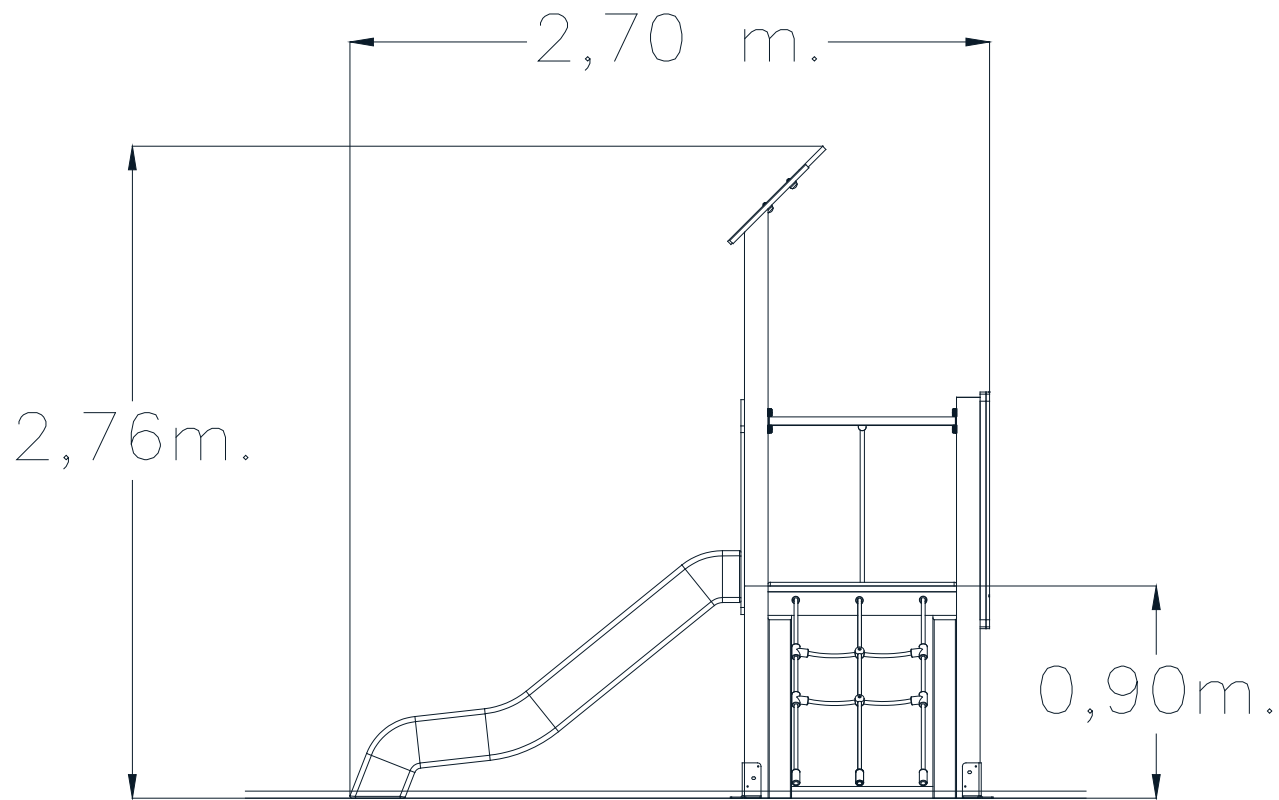

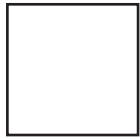

Agujero para poste
Trou por le porteaux
Hole for post



Colocación de los postes
Trou por le porteaux
Hole for post



Longitud del poste
Post length
Longueur du poteau

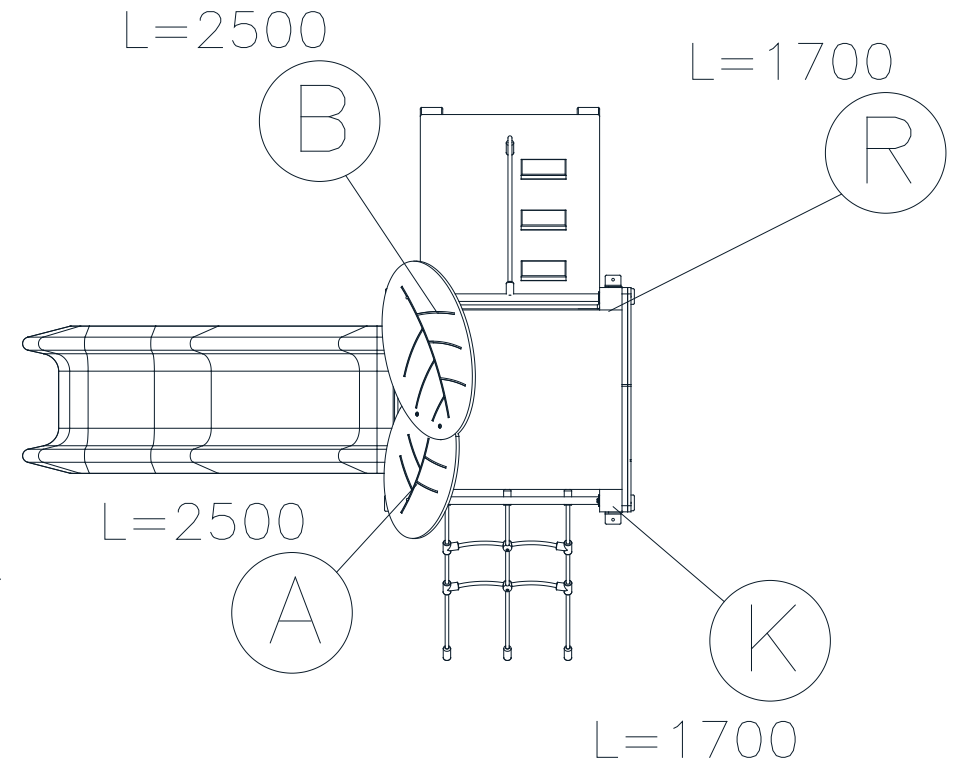
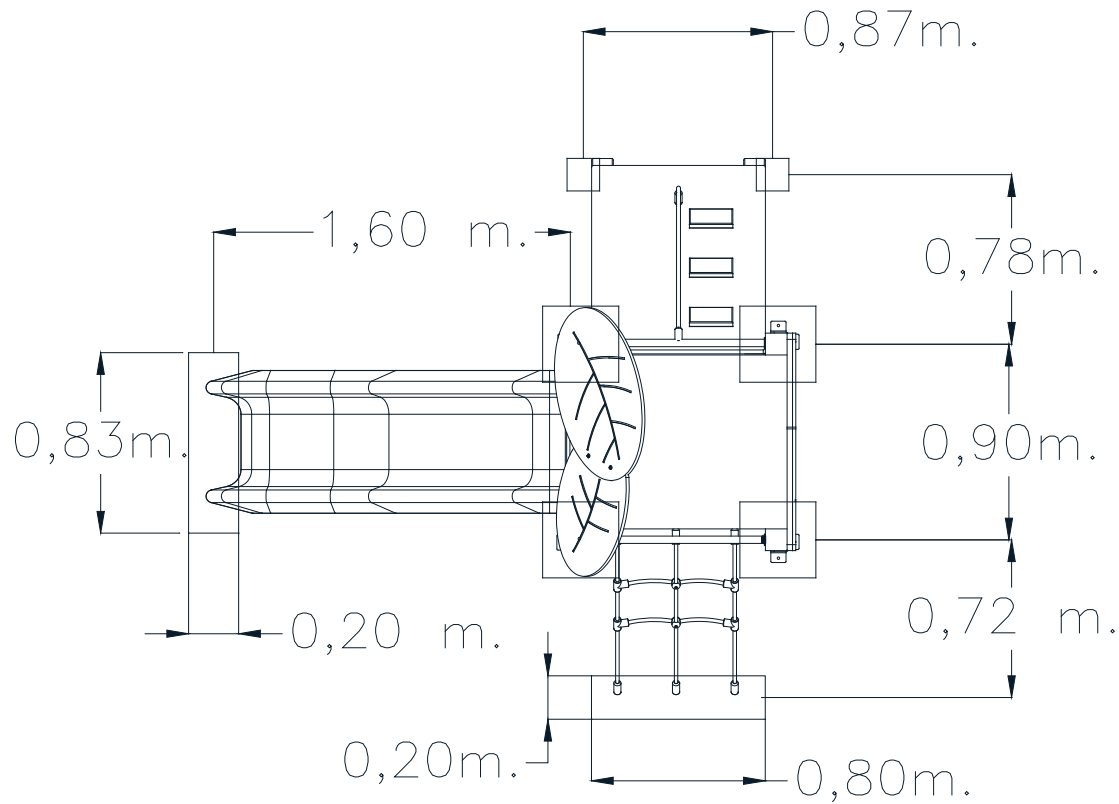

SB

FIJACIÓN A TIERRA | FIXATION AU SOL | FIX ON THE FLOOR

1. Poste | Poteau | Post
2. Superficie juego | Surface de jeu | Playing surface
3. Cemento | Scellement | Concrete H-200
4. Capa grave | Sous couche drainante | Grave layer

24h.

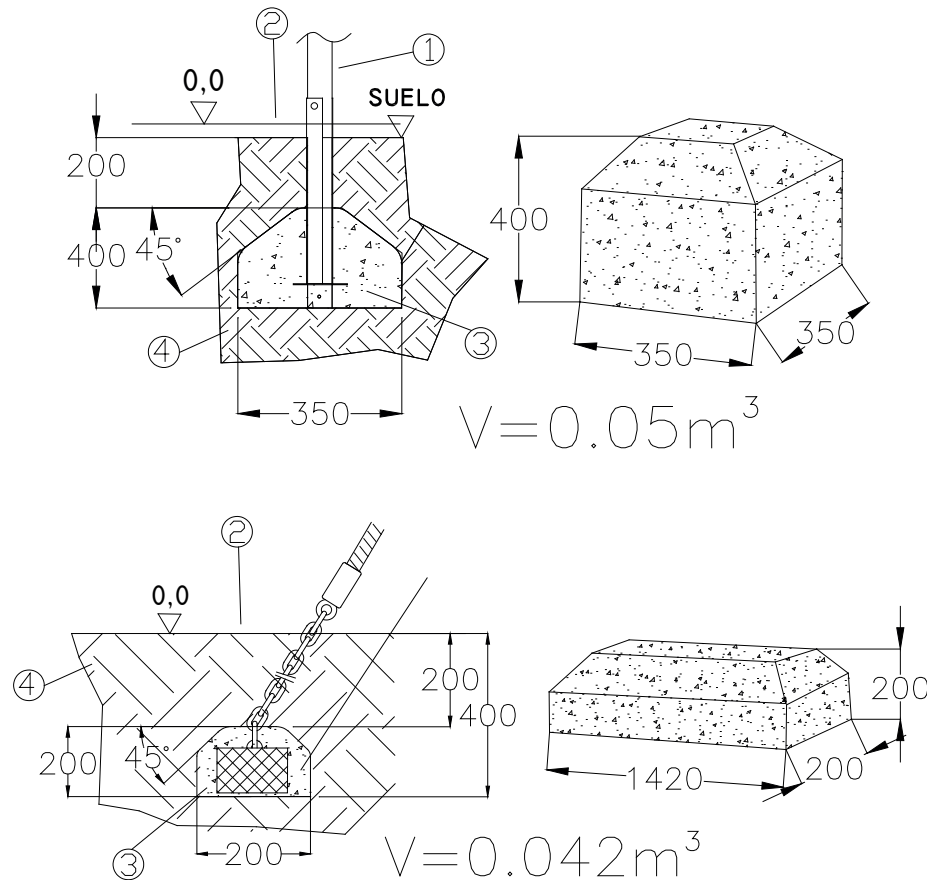

IMPORTANT: para el montaje y cimentación del juego son necesarias herramientas empleadas habitualmente en la construcción.

IMPORTANT: pour le montage et le scellement du jeu prévoir l'outillage de maçonnerie courant.

IMPORTANT: for installation and foundation of the game are necessary tools usually employed in the construction.

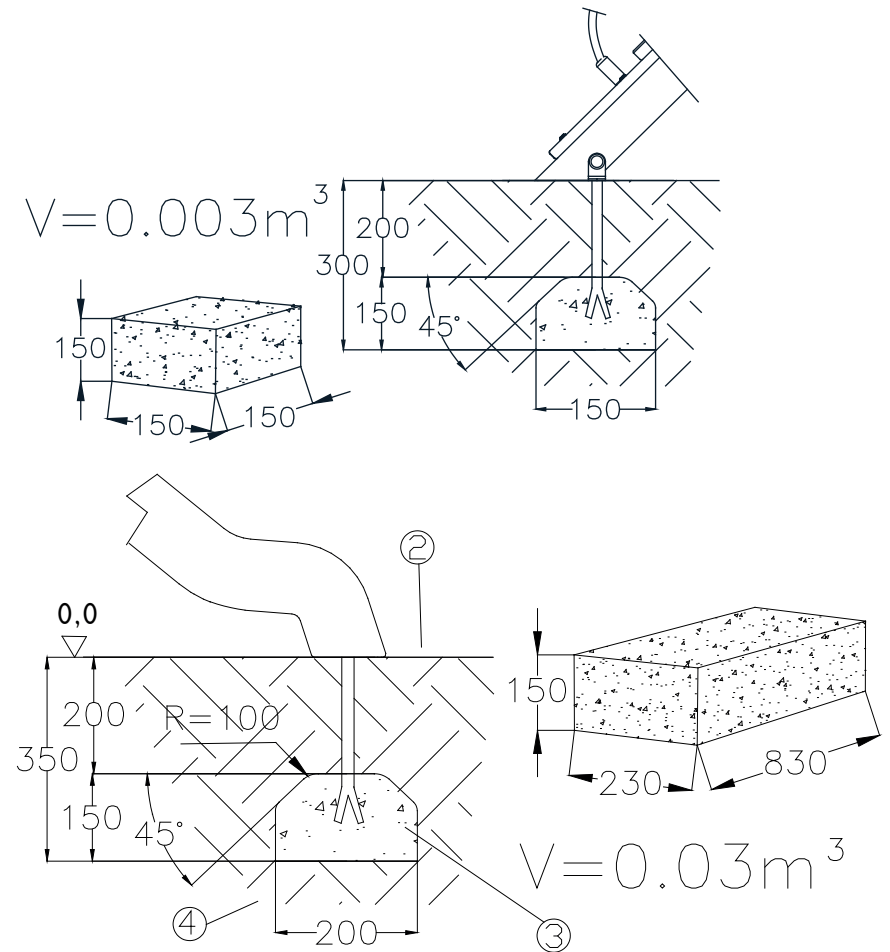

SB

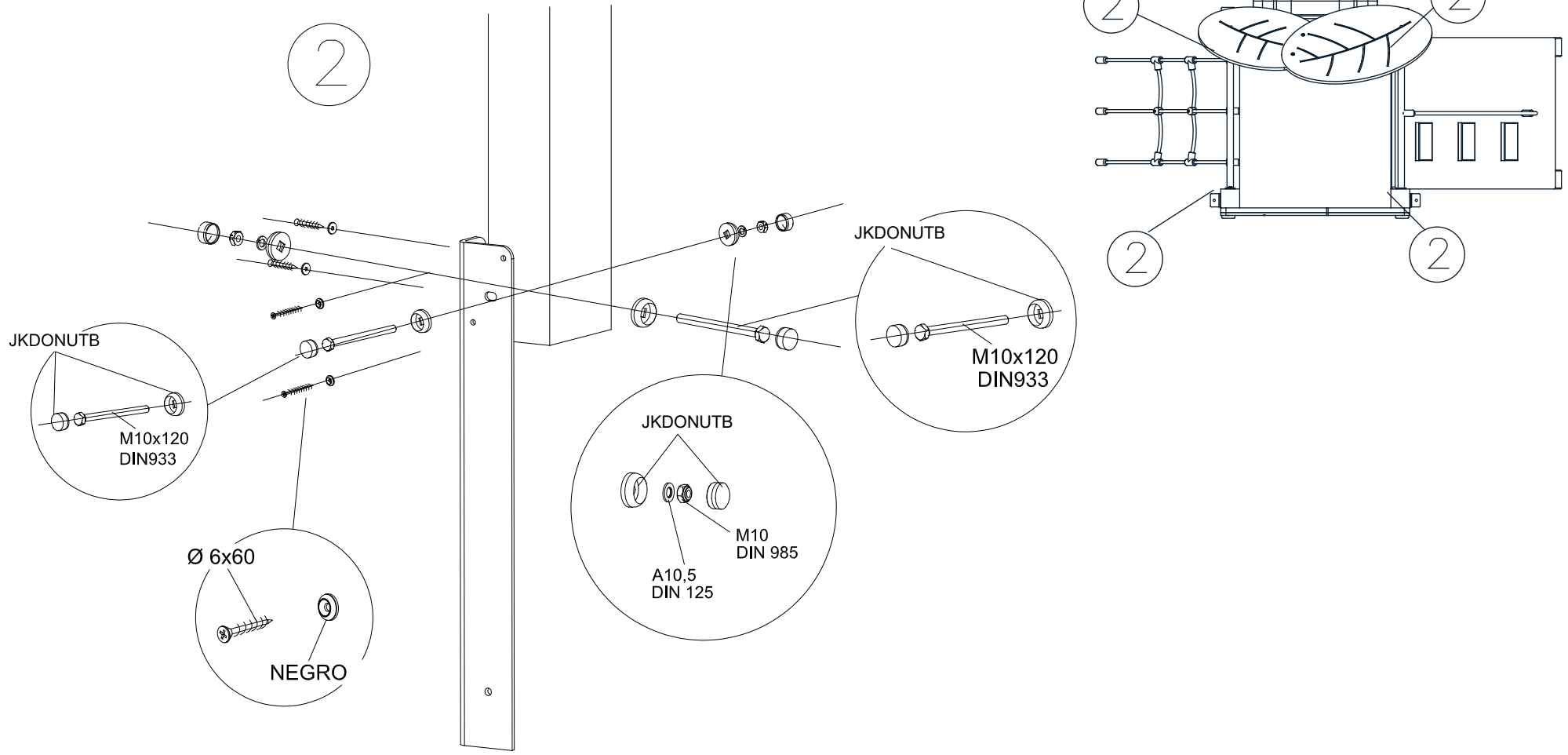

SD

FIJACIÓN A SOLERA | FIXATION AU SOL | FIX ON CONCRETE

La superficie de juego debe estar cubierta por un suelo que absorba el impacto, según normativa EN-1176-1:2017

La surface de jeu doit être recouverte de terre pour absorber l'impact, conformément à la réglementation EN 1176-1: 2017

The playing surface must be covered by a floor to avoid the impact, according to standard EN-1176-1:2017

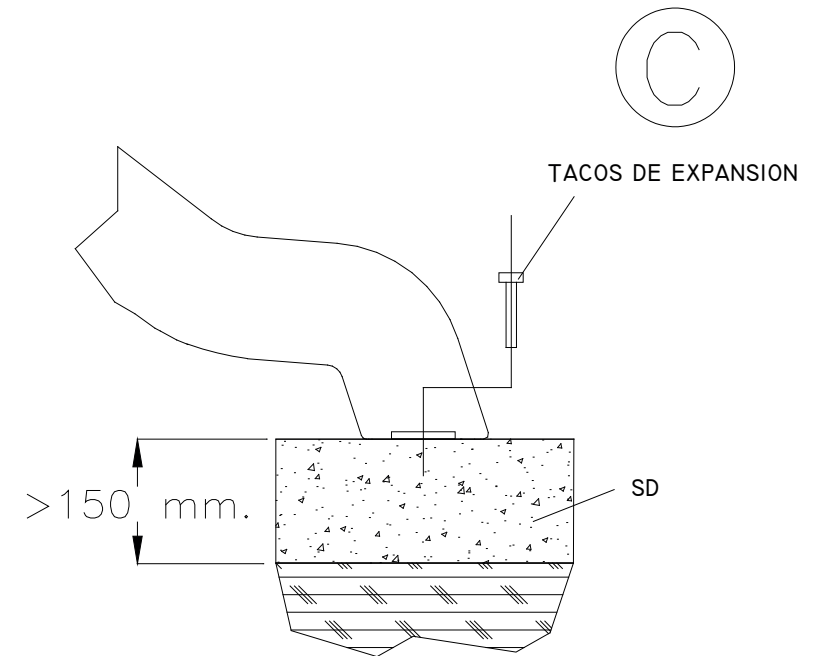
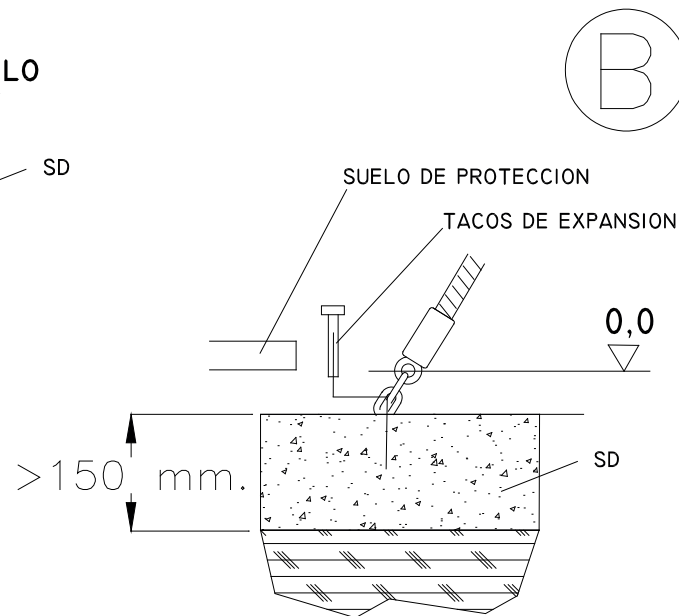
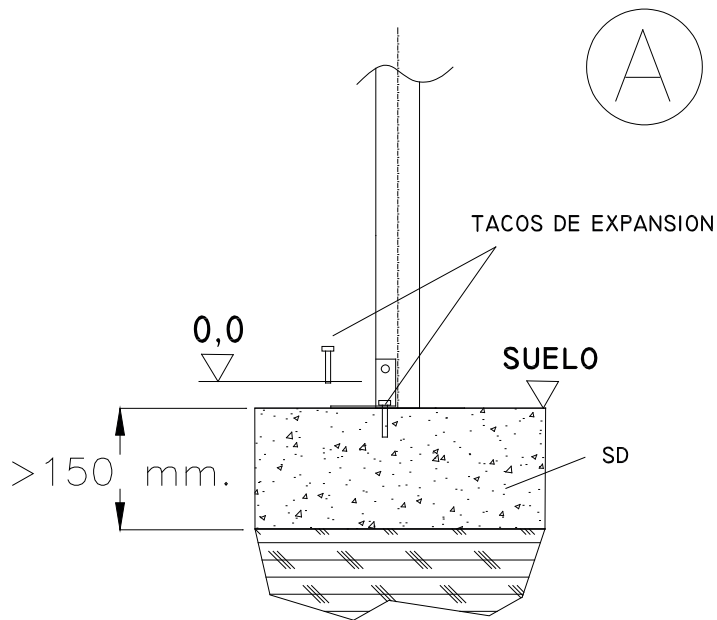

SD

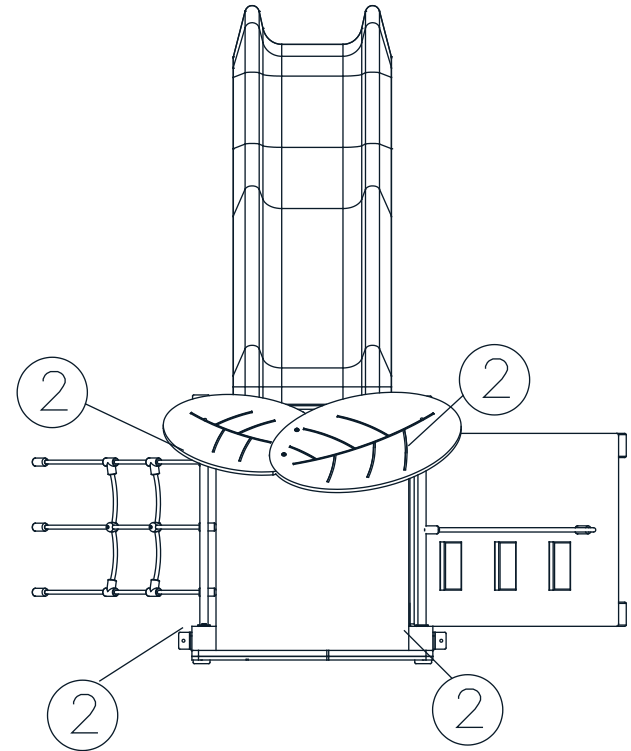
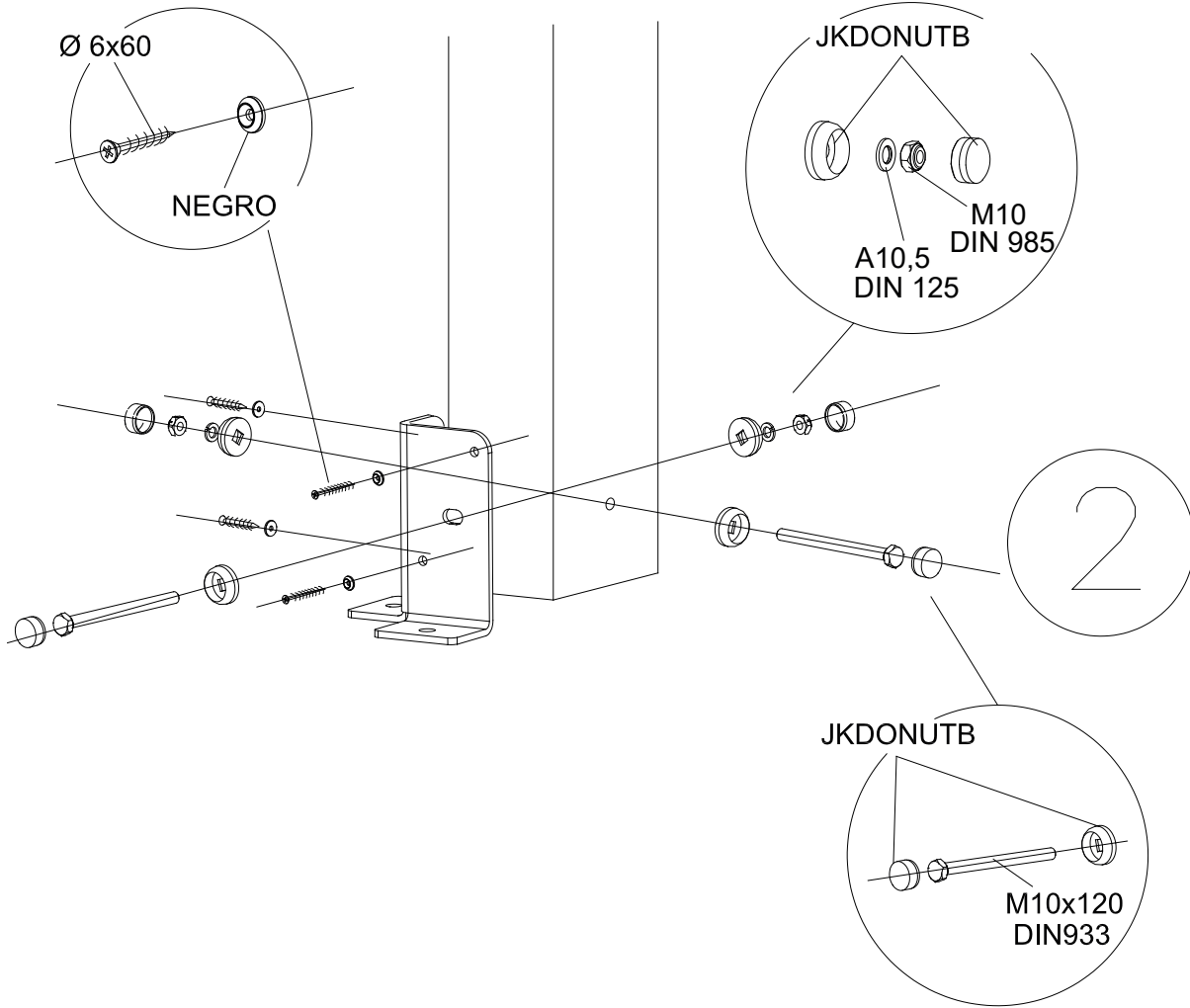

1

E

Colocación de los postes
Trou pour le portaux
Hole for post

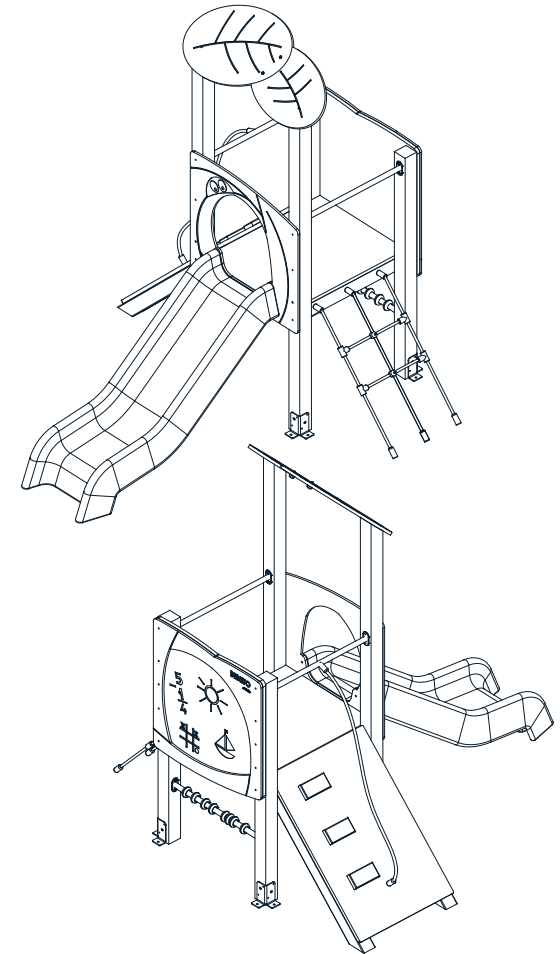
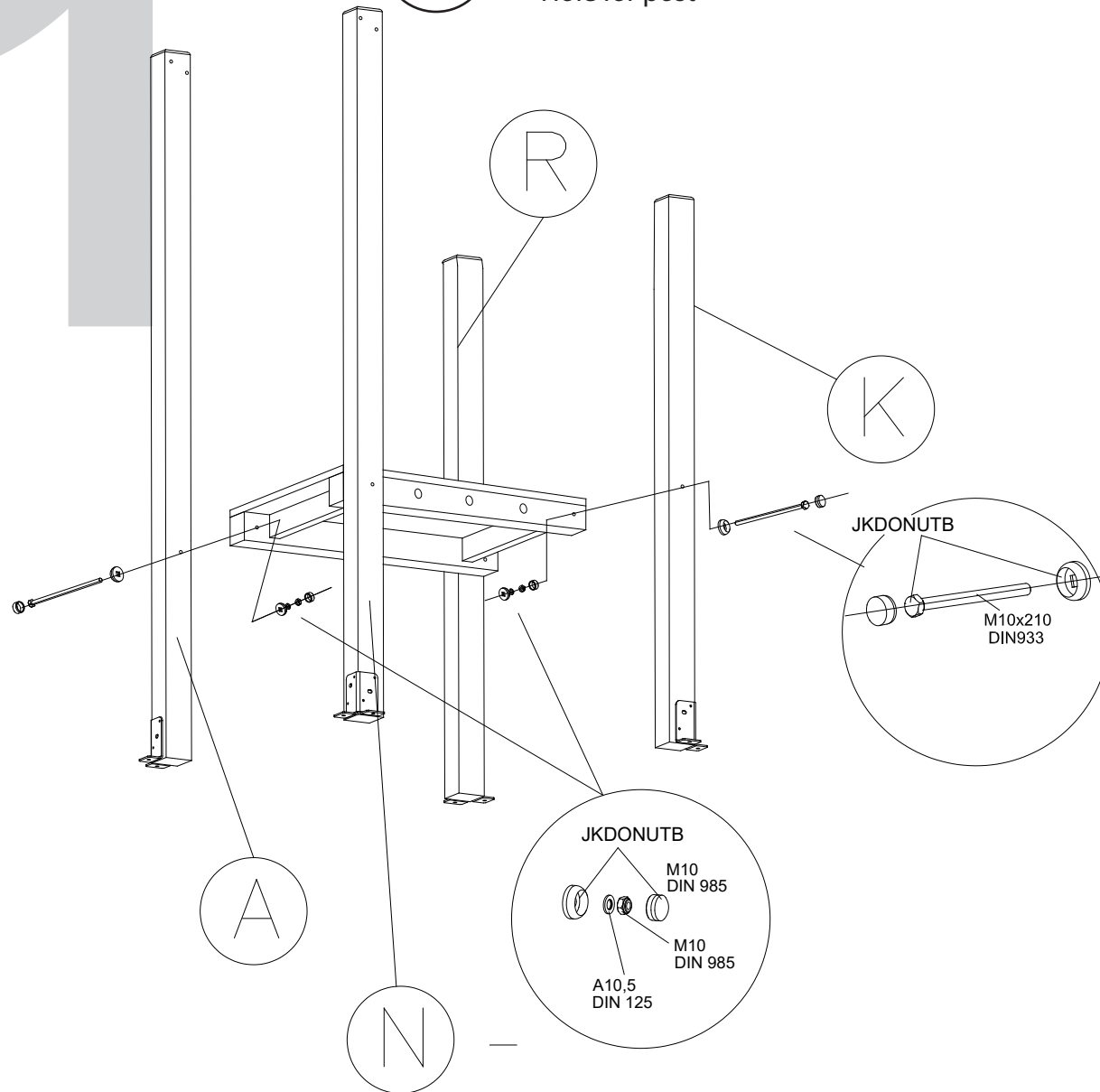

2

Colocación de los postes
Trou por le portaux
Hole for post

E

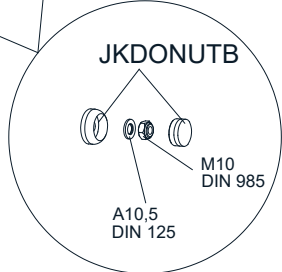
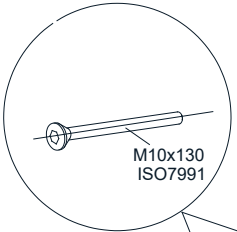

R

K

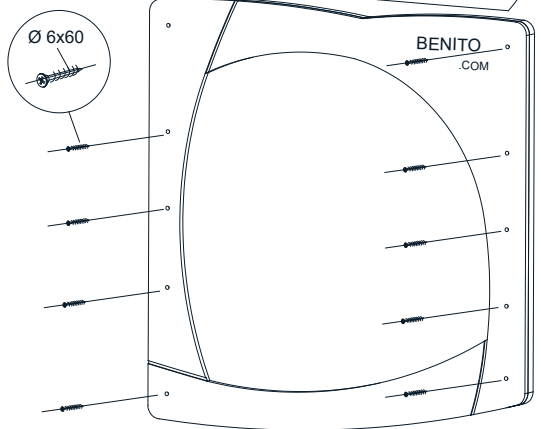
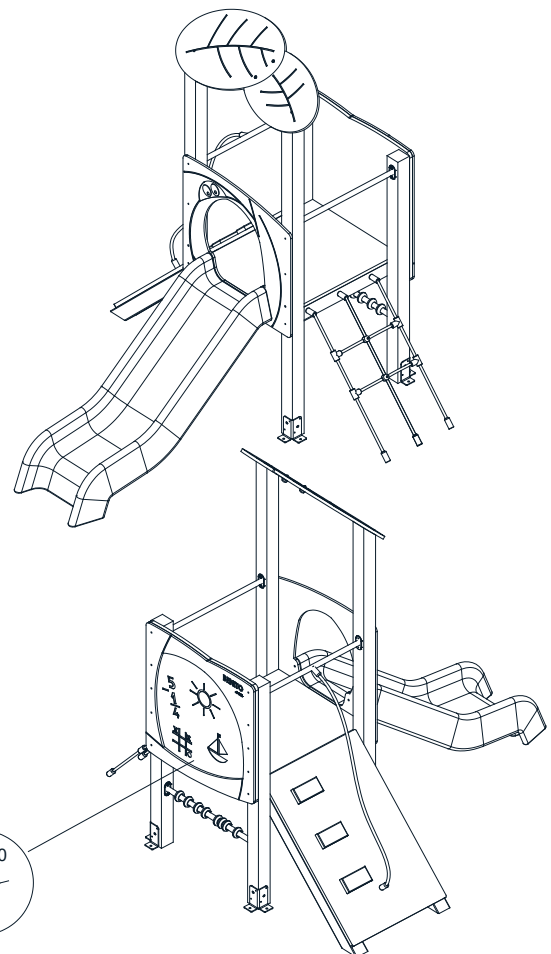

colocacion de este tirafondo
contra el tablero de la base

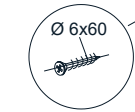

colocacion de
este tirafondo
contra el tablero
de la base

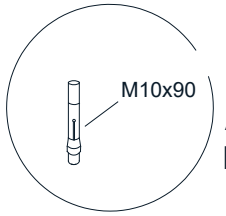
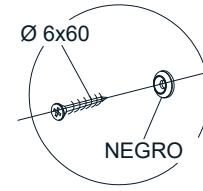
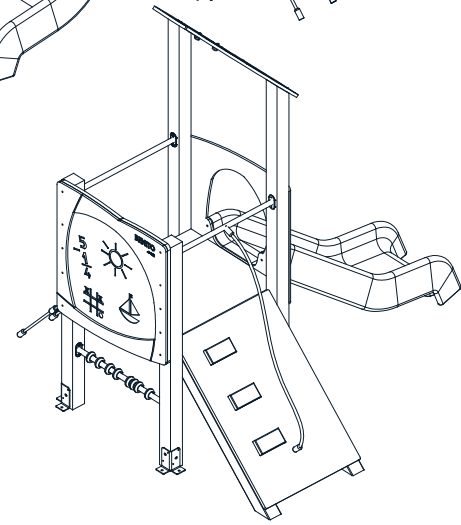
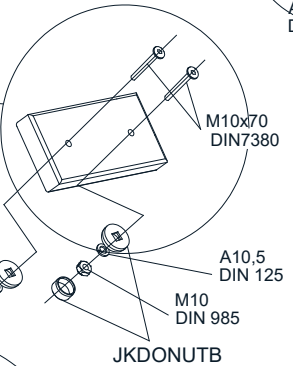
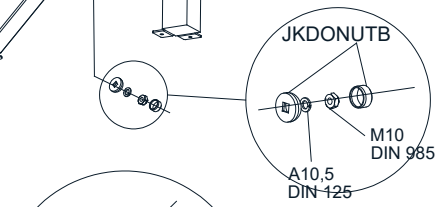
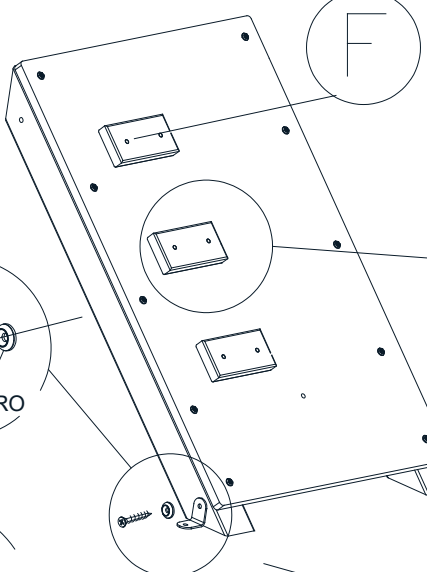
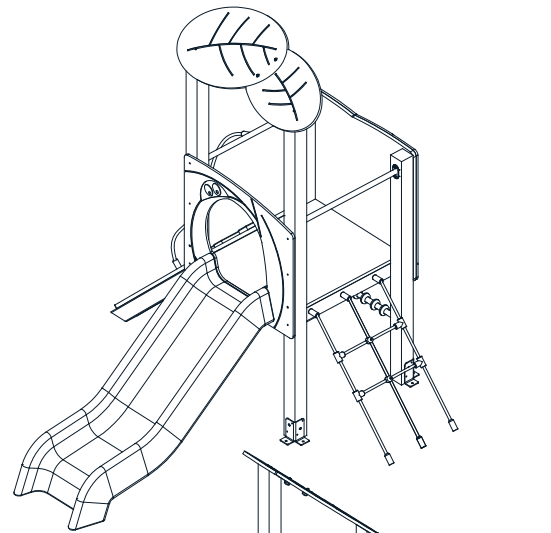
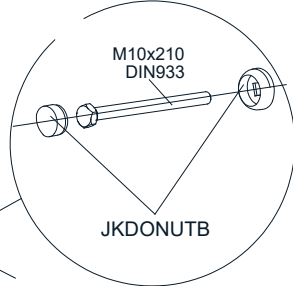
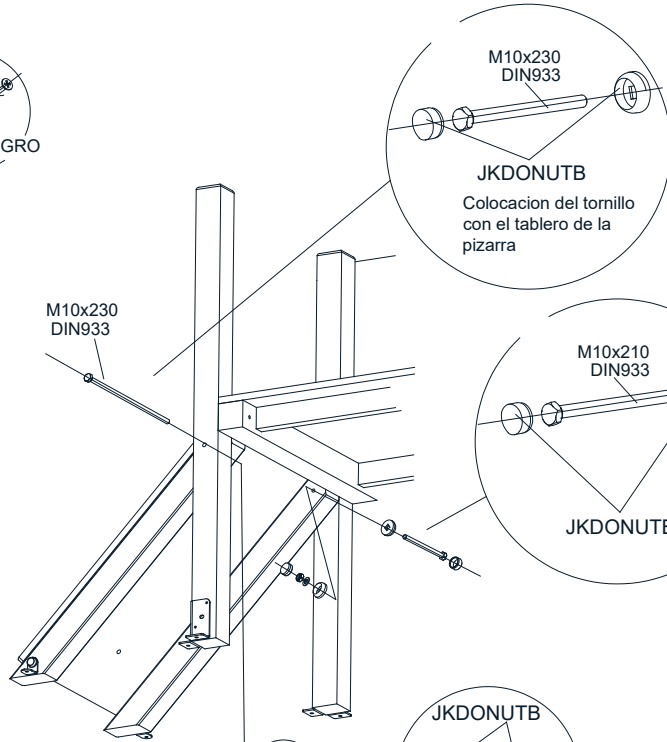
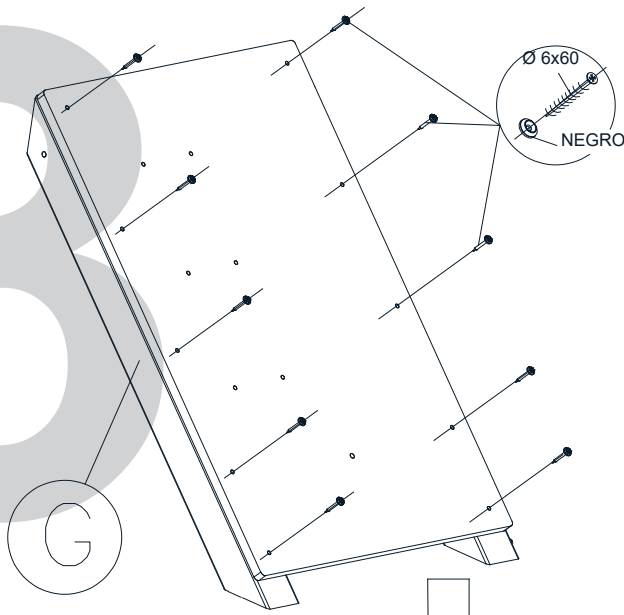

ANCLAJE
EN SD



ANCLAJE
EN SB



Colocación de los postes
Trou por le portaux
Hole for post

4

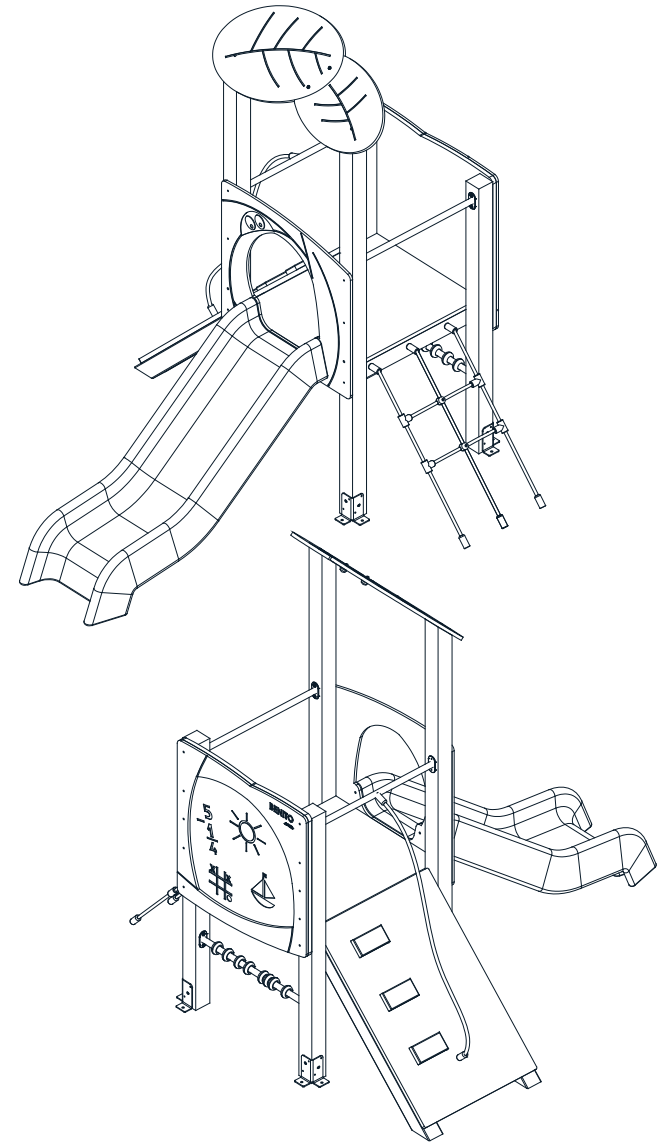
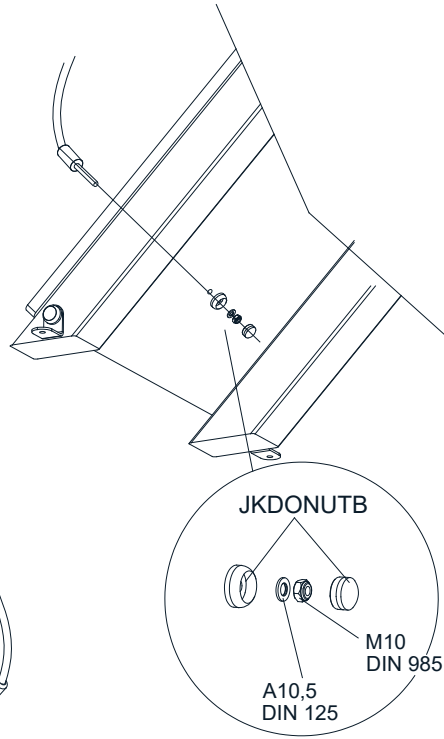
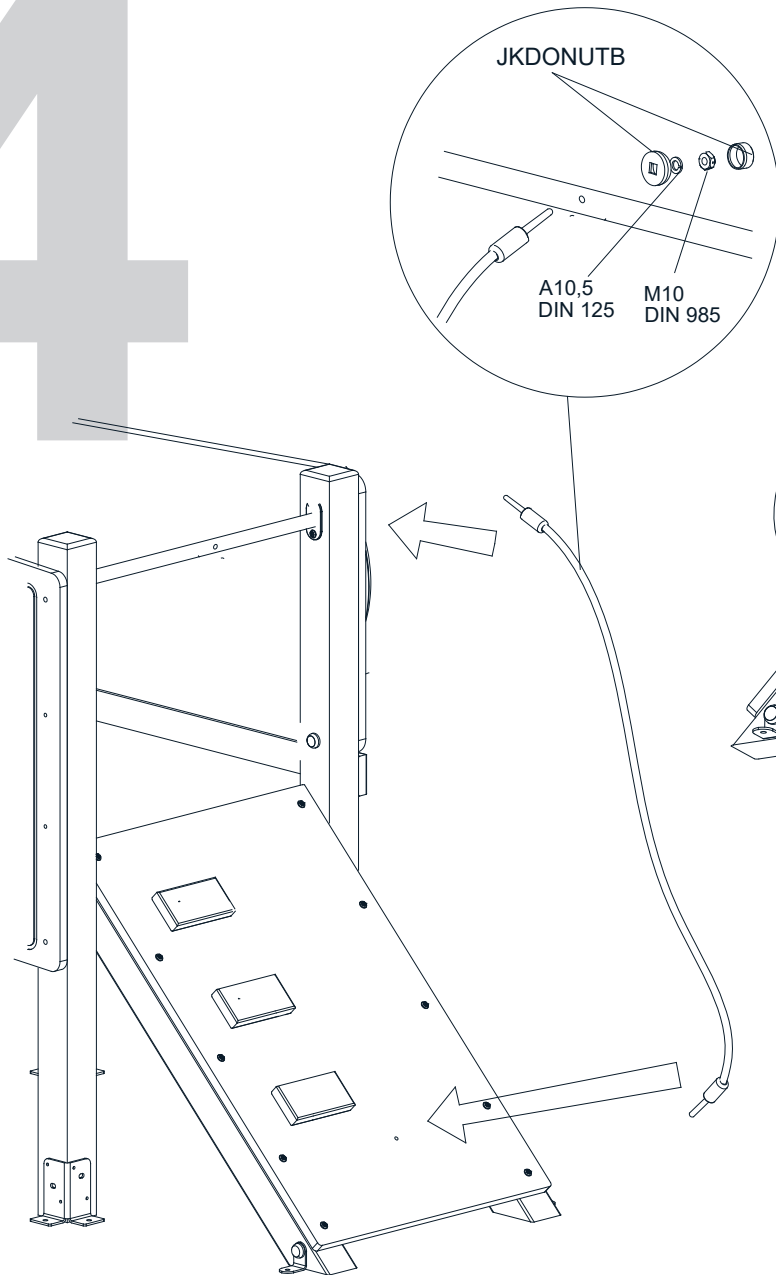

5

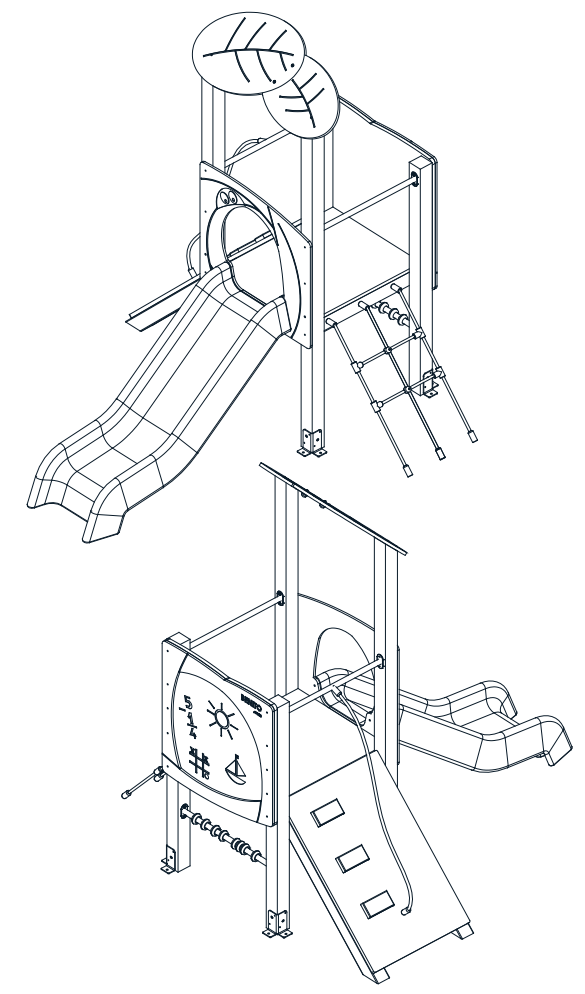
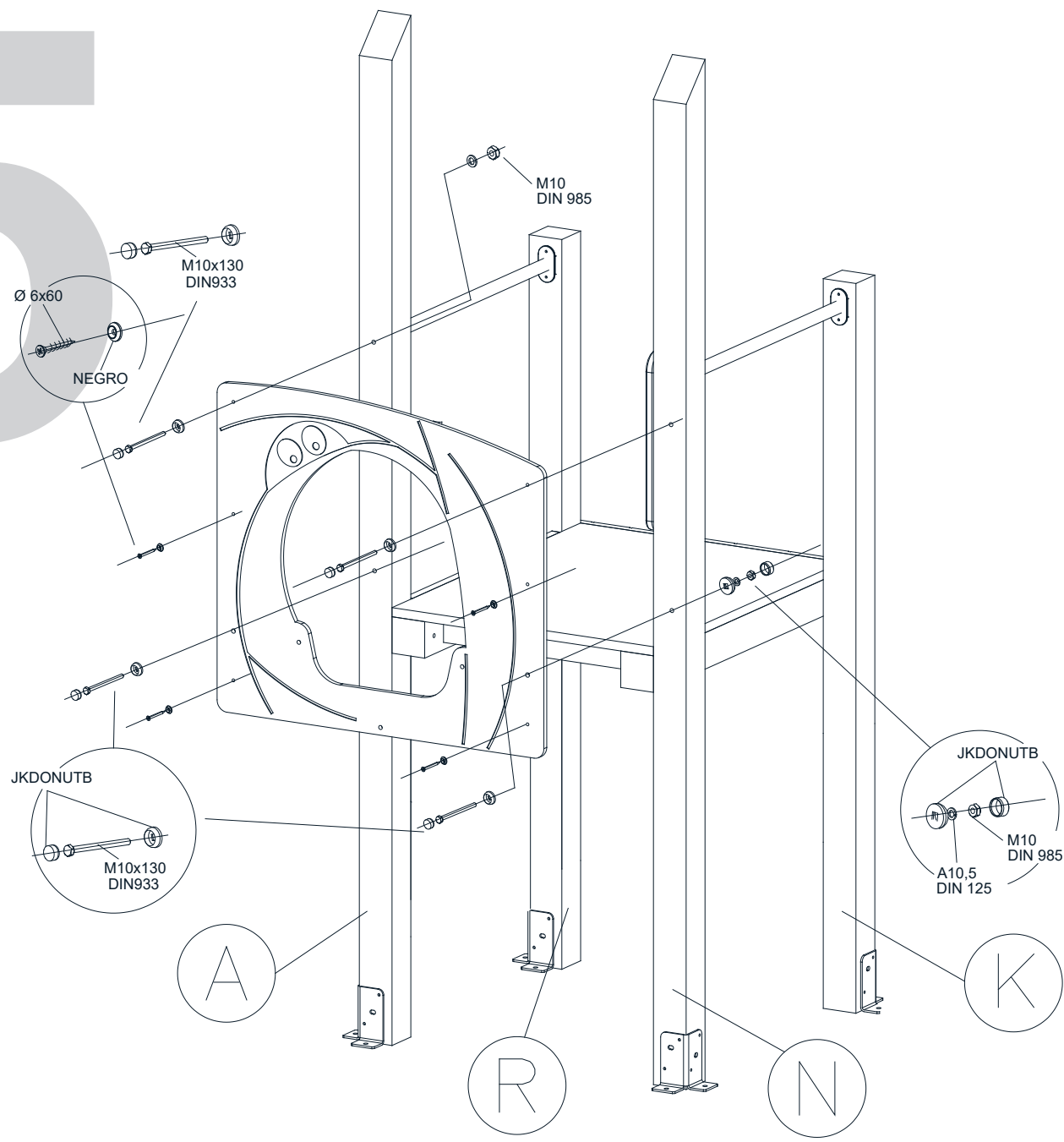

6

E

Colocación de los postes
Trou por le portaux
Hole for post



Coincidir el interior del tubo con
el apriete de tuerca del panel
Faire coincider l'intérieur du tube avec l'écrou
Match the inside of the tube with the nut

COINCIDIR EL INTERIOR DEL TUBO
CON EL APRIETE DE TUERCA DEL
PANEL

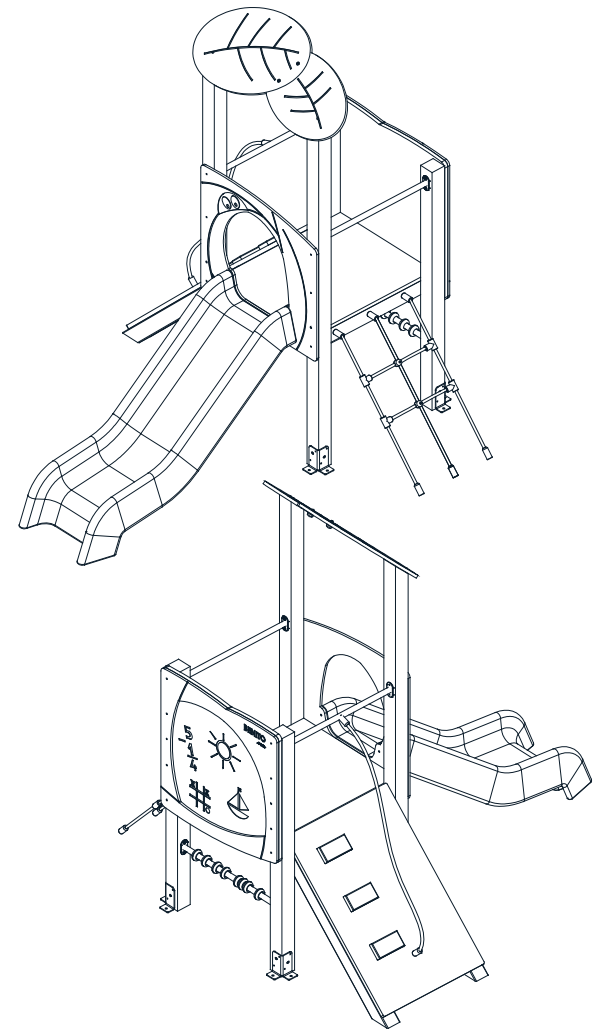
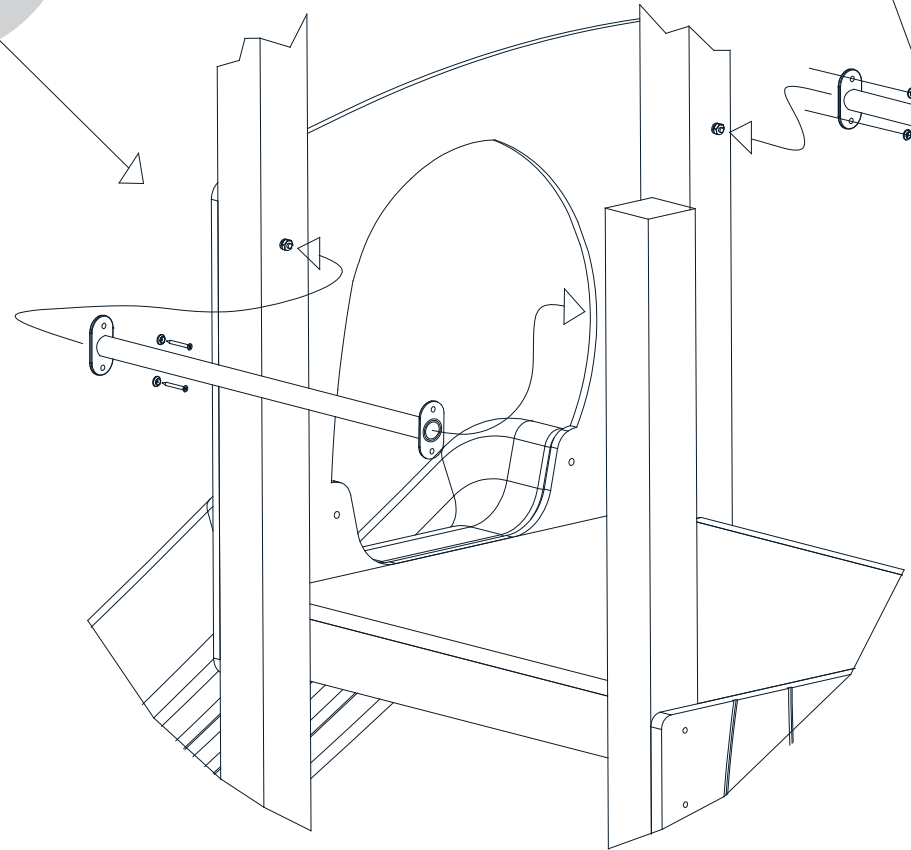
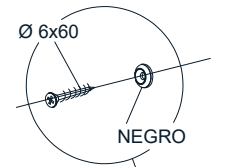

M6x30
ISO7991

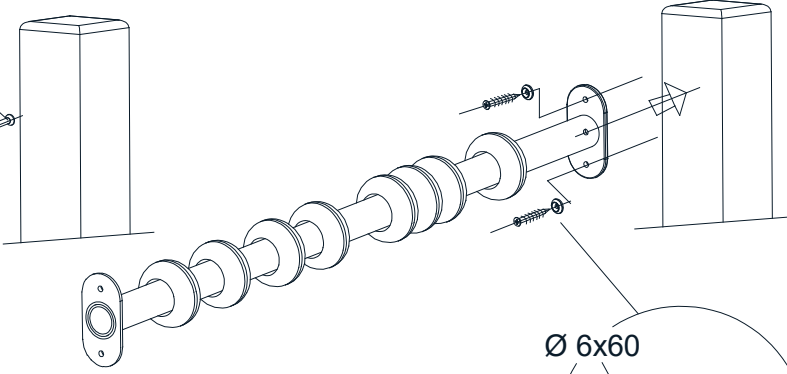
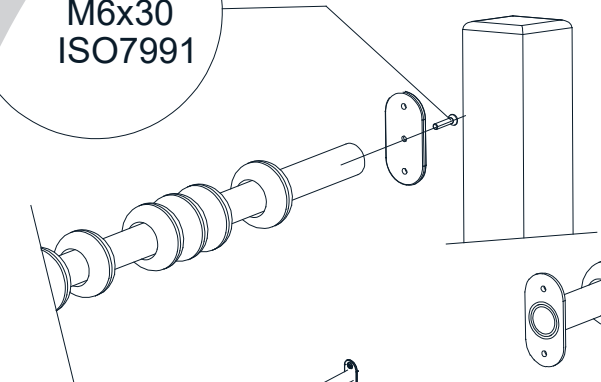

Ø 6x60
NEGRO

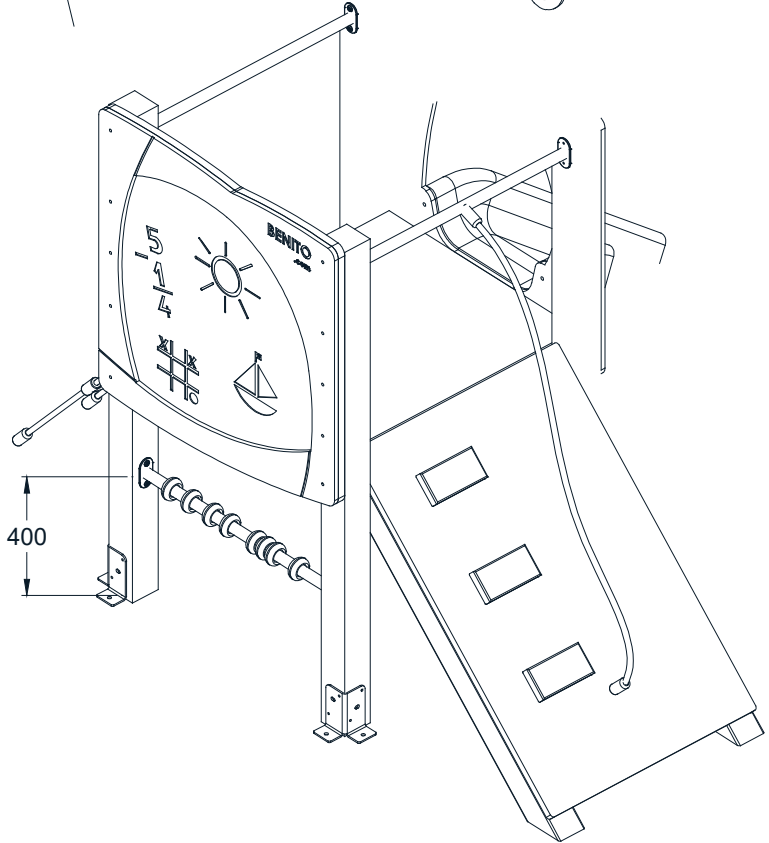
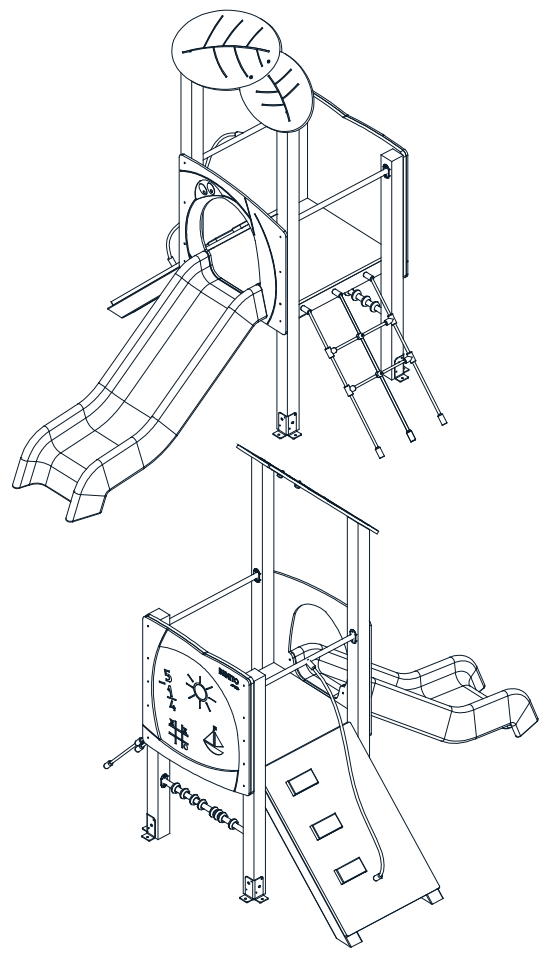

8

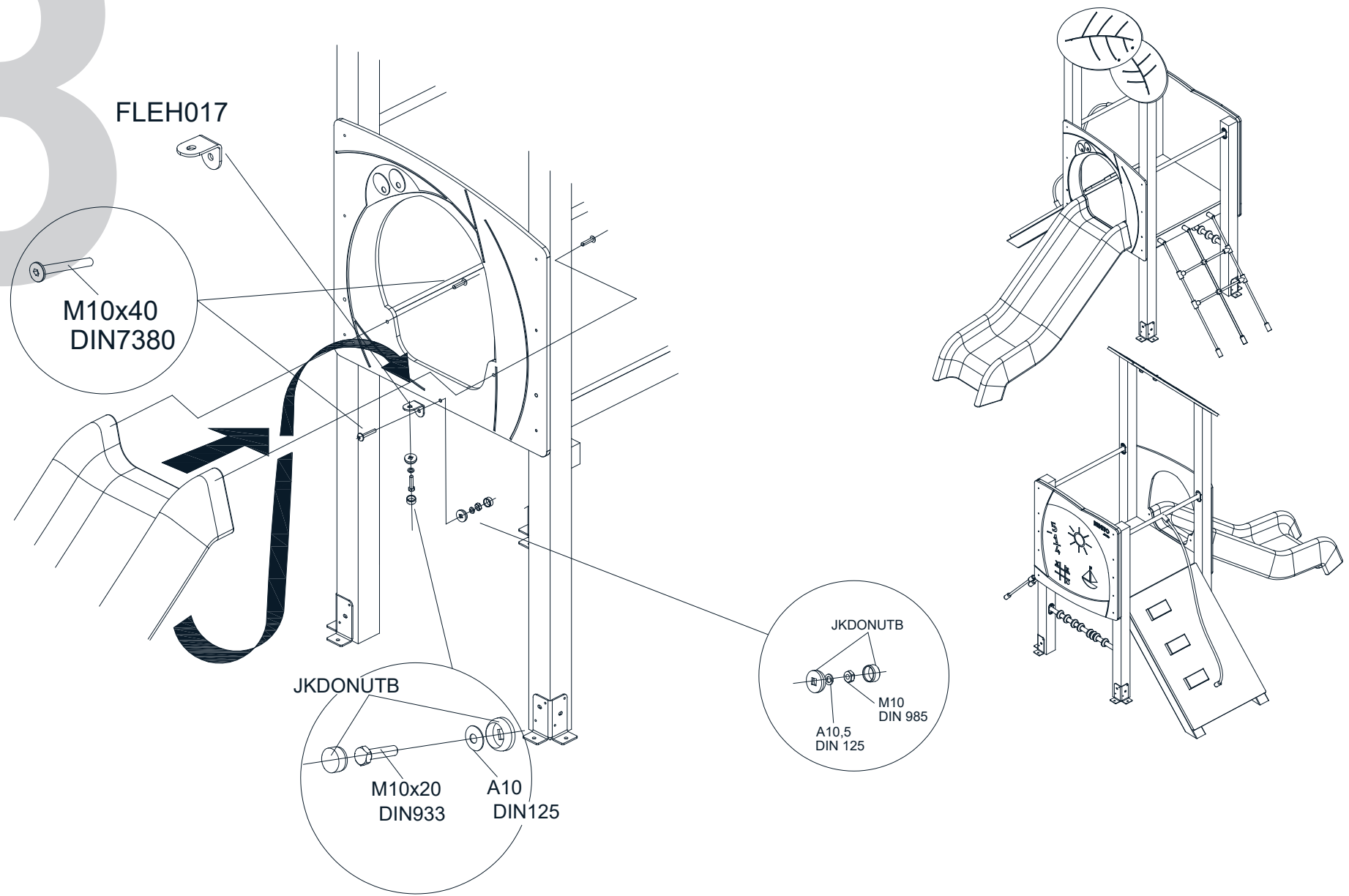

9

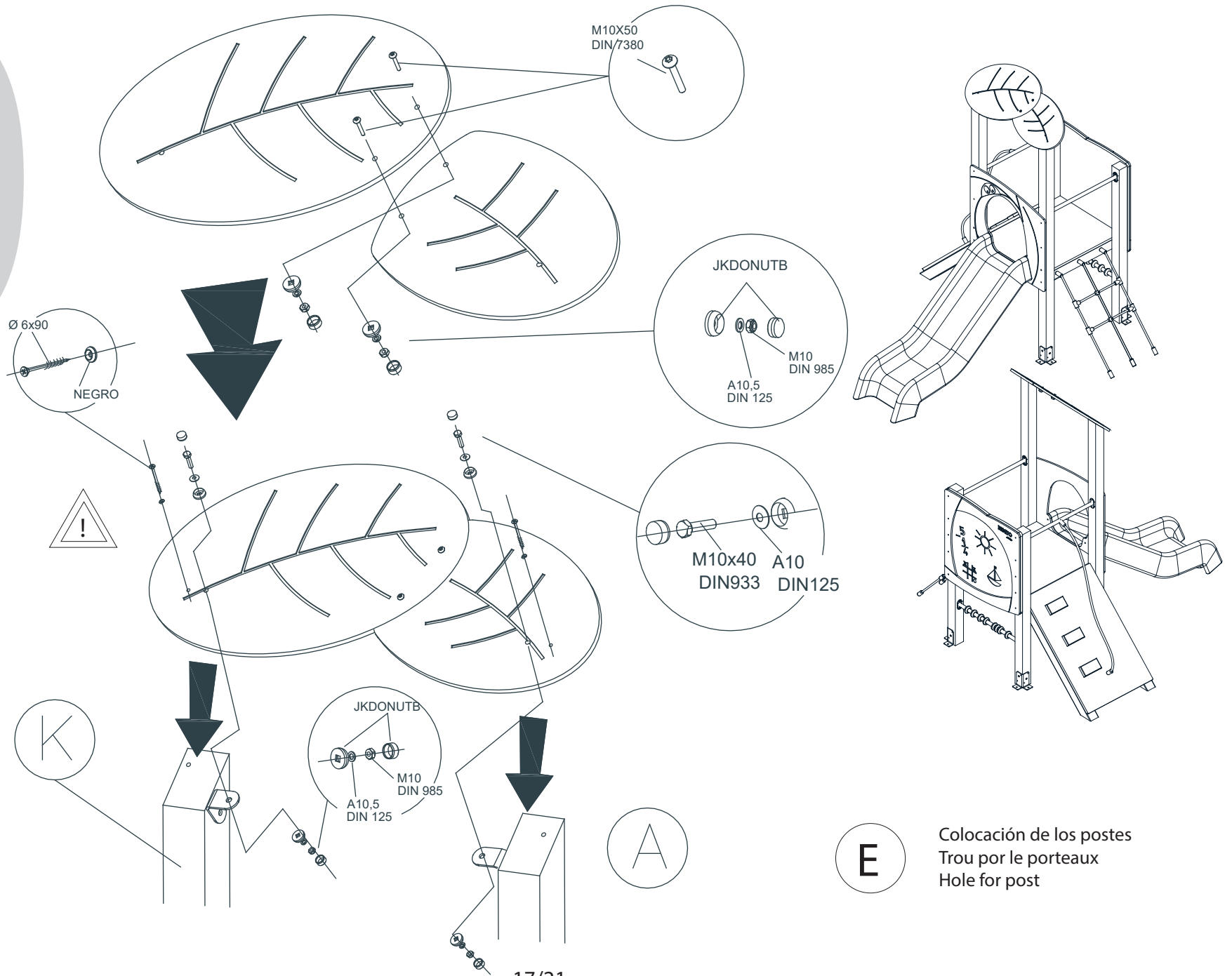

E Colocación de los postes
Trou pour le portaux
Hole for post

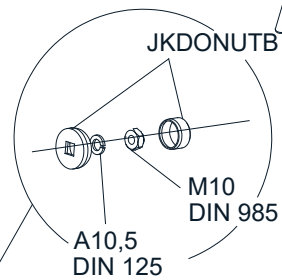
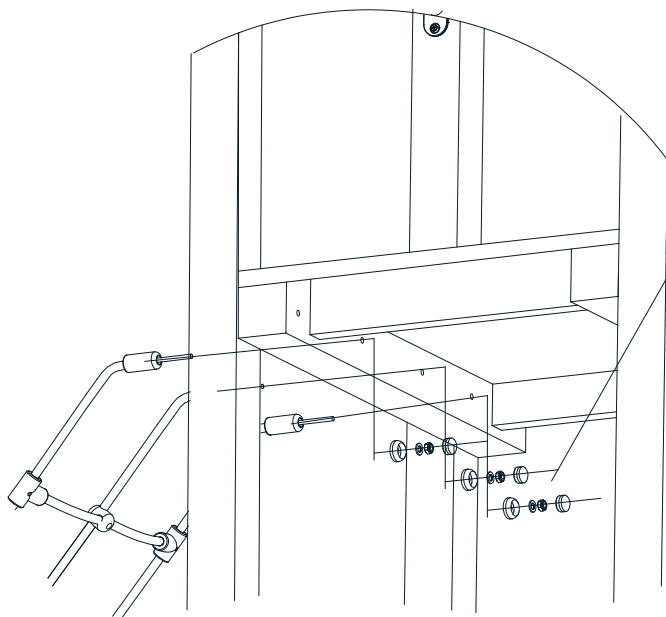
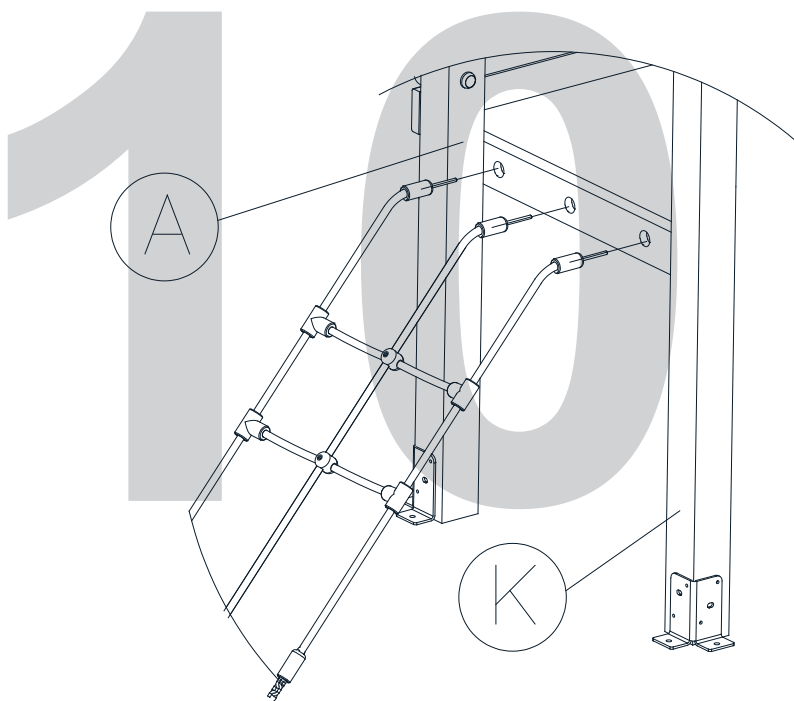

E

Colocación de los postes
 Trou por le porteaux
 Hole for post

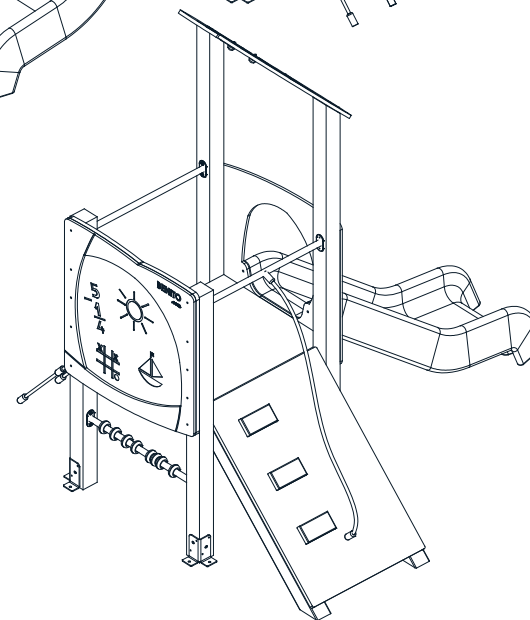
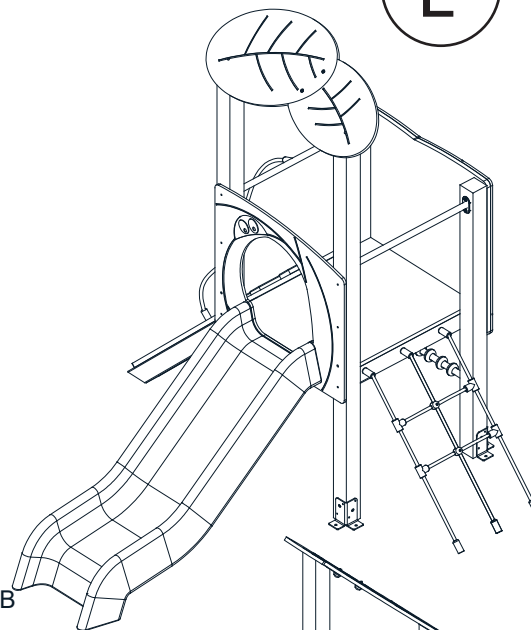

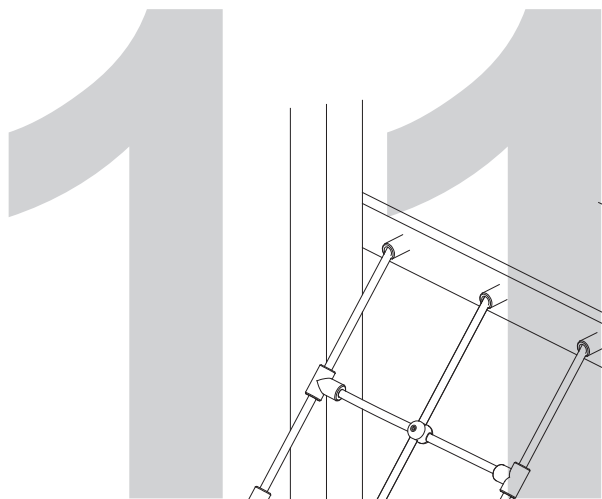

Tensar la cadena segun el plano y cortar sobrante
 Faire tendre la chaîne selon le plan et couner le reste
 Tighten the chain according to plan and cut the leftover

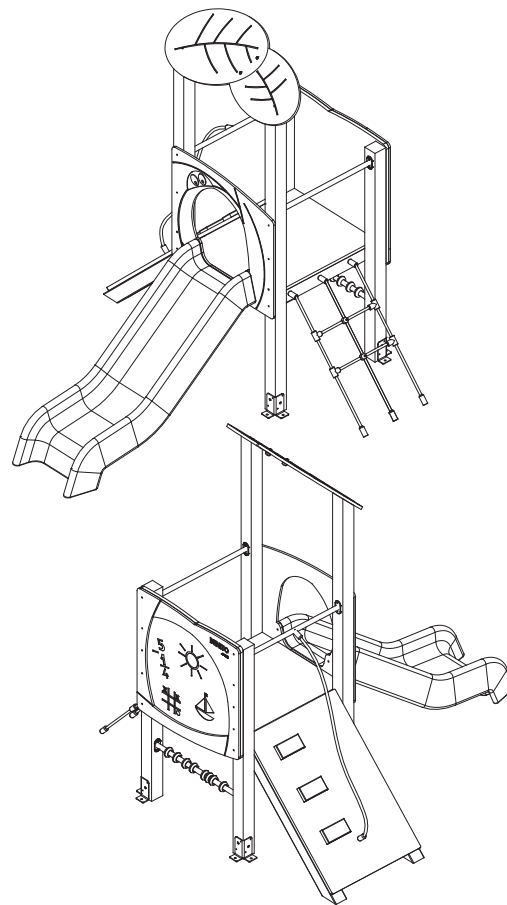
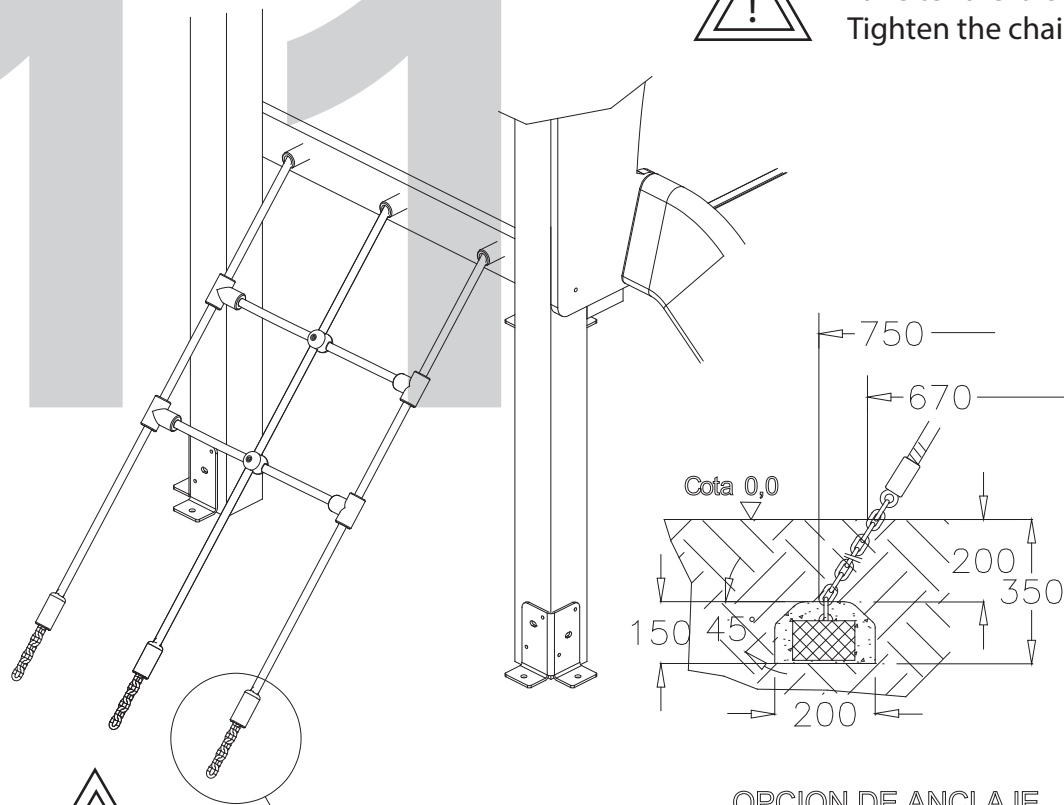

Colocacion de la red en el suelo

POSTE

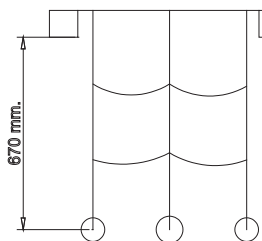

SD CORTAR LA CADENA SOBRANTE.

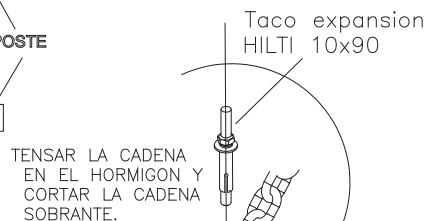

GRILLETE RECTO
6

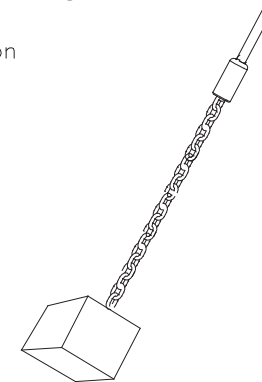

12

SB



SD

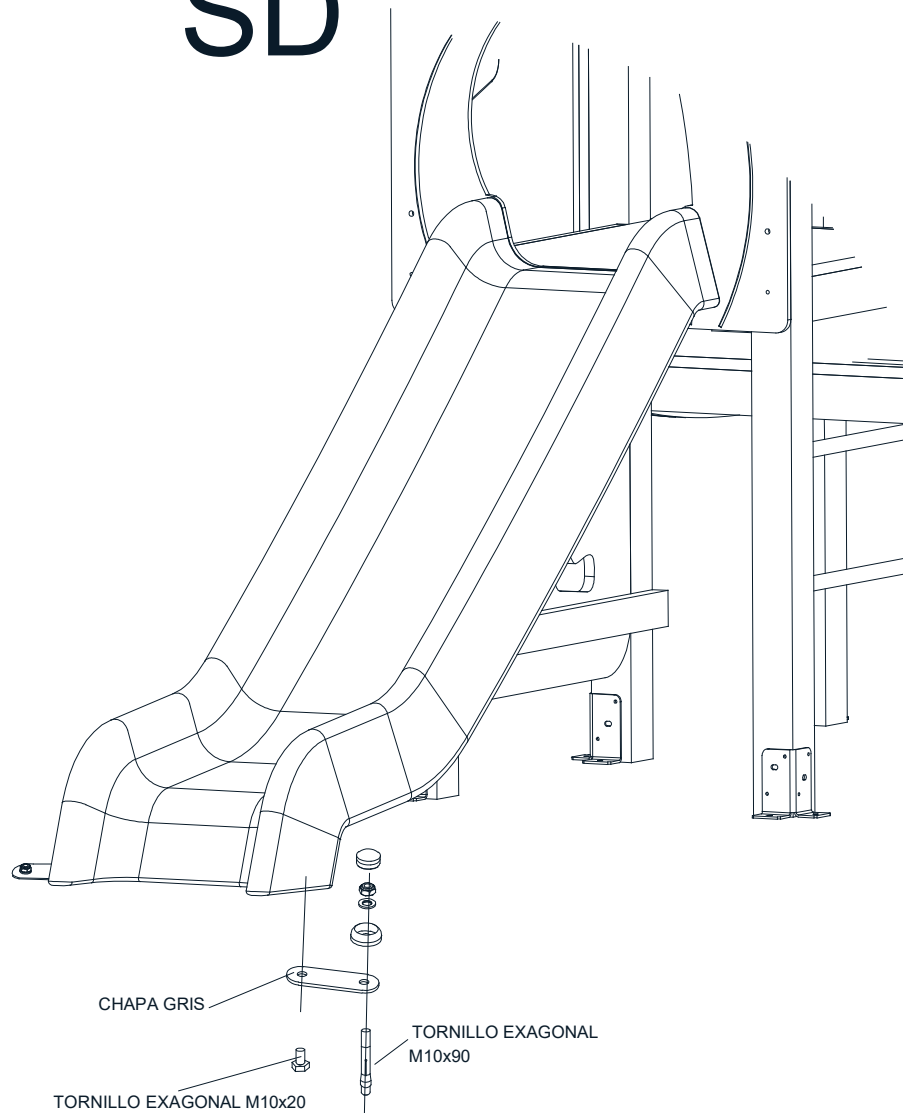

Piezas de recambio
Pièces de rechange
Spare parts

- | | |
|-------------------------------|-------------|
| 1.-TABLERO SOPORTE TOBOGAN | REB-TE-003 |
| 2.-RED SUBIDA A PLATAFORMA 90 | RE-RE001 |
| 3.-TUBO PROTECTOR CUERDA | RJETU001B |
| 4.-TOBOGAN ECO 90 | T-90ECO |
| 5.-TUBO PROTECTOR | RJETU001 |
| 8.-TABLERO PIZARRA | RJEPa-006BE |
| 9.-TABLERO BASE | RJEPa-002 |
| 10.-ZARPA CORTA | RJE-HE001 |
| 11.-TABLERO RAMPA 45° | RJE-PA-014 |
| 12.-MARCO PIZARRA | REB-TE-002 |
| 13.-Panel HOJA Grande | REB-TE-009 |
| 14.-Panel Hoja Pequeña | REB-TE-010 |
| 15.-ABACO | REBMTU002 |
| 16.-PELDAÑO RAMPA | P1190X200F |
| 17.-CUERDA RAMPA | BNF2000-R6 |

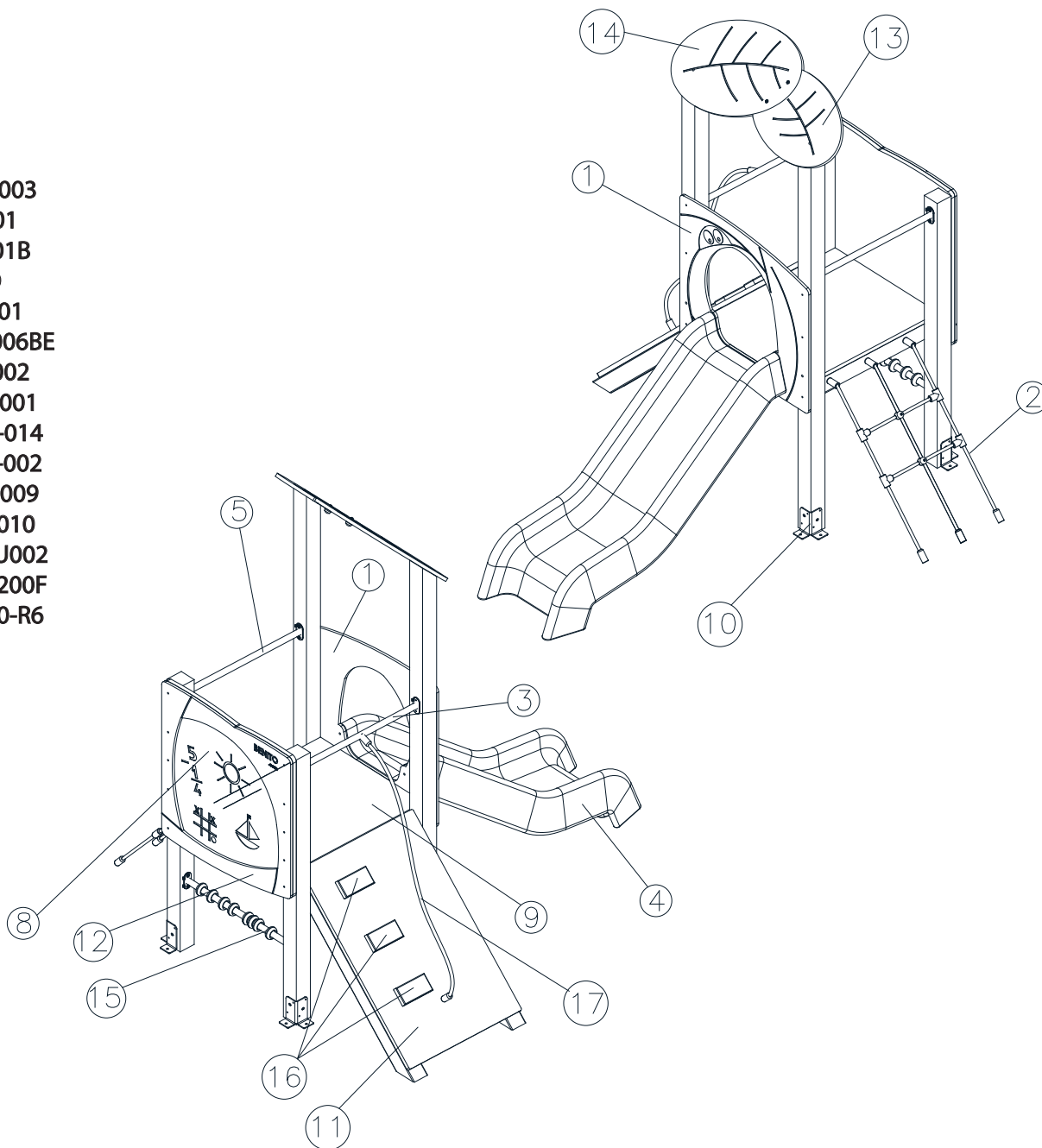

INSPECCIÓN PREVIA A SU USO

- 1.- Comprobar si se han respetado las distancias de seguridad marcadas en el plano adjunto.
- 2.- Limpiar e igualar las áreas de seguridad de las distintas instalaciones de juego.
- 3.- Comprobar los aparatos de juego utilizandolos uno mismo.
- 4.- Comprobar que los tornillos y tuercas estén bien apretados, poniendo mayor atención a aquellos que por la naturaleza del juego son susceptibles de aflojarse.
- 5.- Comprobar si todas las tuercas están debidamente apretadas, y los agujeros cubiertos por tapones.
- 6.- Revisar que los cimientos, se encuentran a la profundidad adecuada.
- 7.- Algunos modelos tienen unos travesaños provisionales atornillados a las patas inferiores con el fin de facilitar y asegurar el transporte de la estructura. Una vez instalado el conjunto retirar dichos travesaños.

INSPECTION AVANT UTILISATION

- 1.- Vérifier avant tout la liberté de la zone de sécurité telle que décrite au plan joint.
- 2.- Nettoyer et aplanir la zone en vérifiant qu'elle ne se chevauche pas avec celle des autres jeux.
- 3.- Contrôler le bon fonctionnement des jeux en les assaillant vous-même
- 4.- Vérifier le serrage de chaque vis ou boulon avec une attention particulière aux axe de rotation et fixations des pièces en mouvement.
- 5.- Contrôles la présence des rondelles et des capuchons étanches.
- 6.- Vérifiez que les massifs de scellement sont assez profonds.
- 7.- Certains modèles ont des traverses temporaires vissées aux pieds inférieurs afin de faciliter et sécuriser le transport de la structure. Une fois l'ensemble installé, retirez lesdites barres transversales.

INSPECTION PRIOR TO USE

- 1.- Check if you have the necessary clearances security marked on the attached map.
- 2.- Clean and level the security areas various gaming facilities.
- 3.- Check gaming devices using them yourself.
- 4.- Check that nuts and bolts are tight, paying more attention to those who by the nature of are susceptible to loose the game.
- 5.- Check that all bolts are properly tightened, and holes covered with gaps.
- 6.- Check that the foundation, are at the proper depth.
- 7.- Some models have temporary crossbars screwed to the lower legs in order to facilitate and secure the transport of the structure. Once the set is installed, remove said crossbars.