

PLEASE BE ADVISED THAT THE SECURITY BAR MUST BE INSTALLED FACING IN THE CORRECT DIRECTION.

PLEASE SEE ILLUSTRATION BELOW.

OK

ART. NR. 8500 SECURITY BAR FOR SWING SEAT

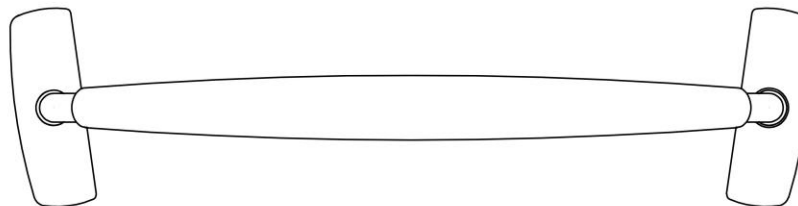
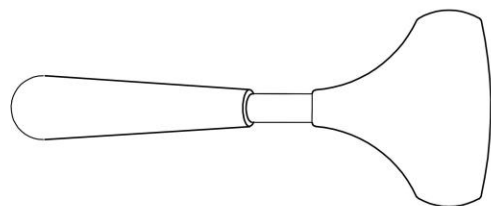

NOT OK

ART. NR. 8500 SECURITY BAR FOR SWING SEAT

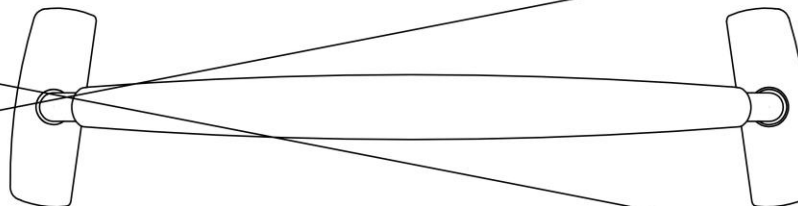
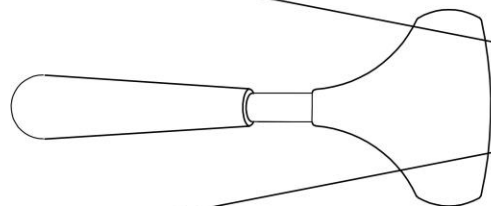

R&T STAINLESS A/S 20110902

MOUNTING INSTRUCTIONS FOR SECURITY BAR FOR SWING SEAT ART. NO. 8500 /

MONTAGEANWEISUNG FÜR SICHERHEITSBÜGEL FÜR SCHAUKELSITZ ART. NR. 8500

ITEM NR. / STÜCK NR.	PART / TEIL	QTY/ STCK
B	SECURITY BAR / SICHERHEITSBÜGEL	1
C	COVER / ABDECKKAPPE	2
D	PINS / STIFTE	4

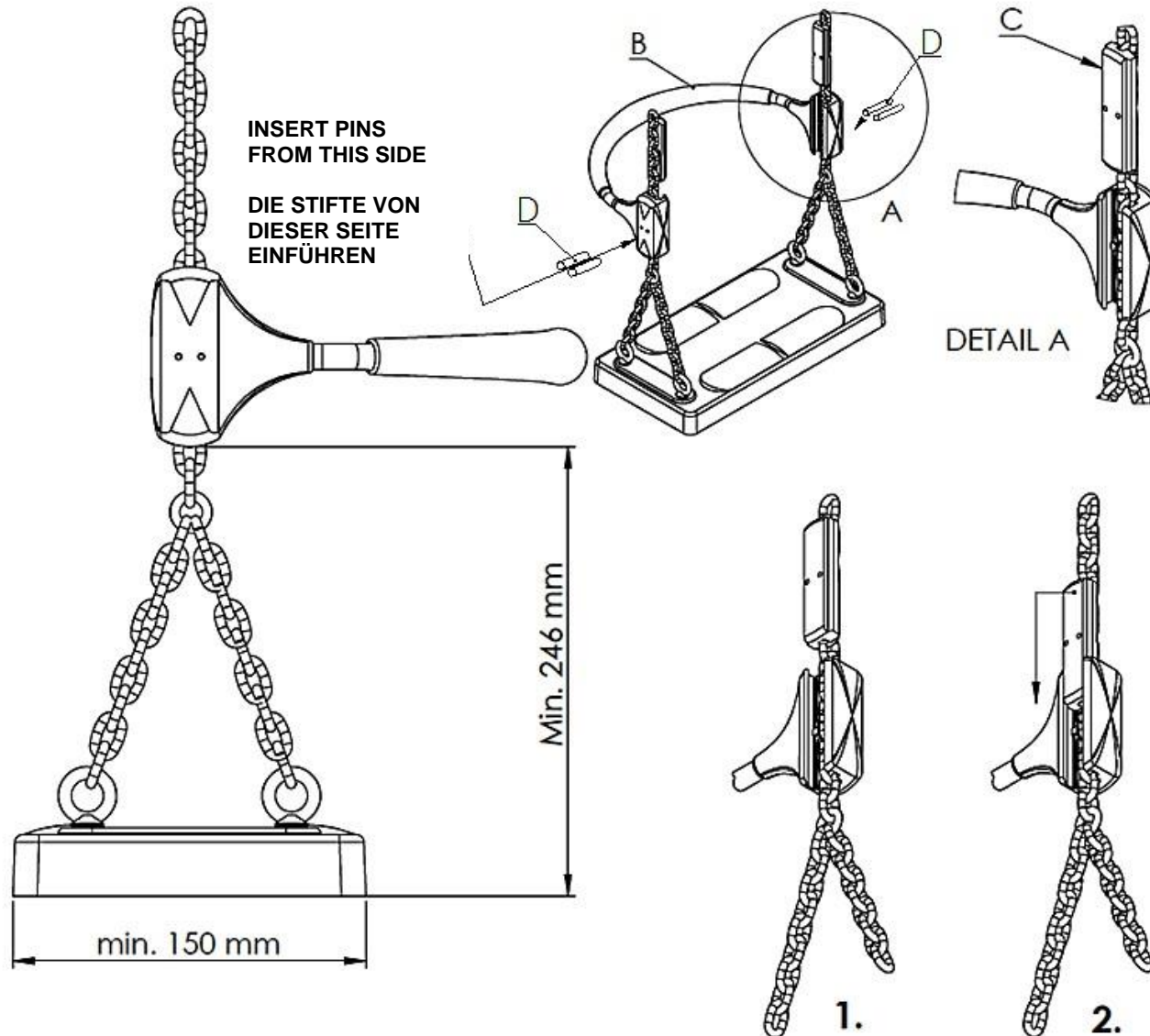

**PLEASE NOTE! /
UNBEDINGT BEACHTEN !**

THE SECURITY BAR MUST BE INSTALLED IN SUCH WAY THAT MAKES JUMPING OFF INTO THE MIDDLE OF A 6-SWING-BAY AND 3-SWING-BAY FRAME IMPOSSIBLE /

DEN BÜGEL SO EINBAUEN, DASS ER DAS ABSPRINGEN IN DIE MITTE VON 6-FACH UND 3-FACHSCHAUKELN VERHINDERT.

THE SECURITY BAR MUST BE INSTALLED ON THE SIDE OF THE SWING SEAT WHERE THE AREA OF IMPACT OF THE SWING SEATS MEET. /

DER BÜGEL MUSS DAZU AUF DER SITZSEITE MONTIERT WERDEN, AUF DER DIE AUFPRALLFLÄCHEN DER SCHAUKELSITZE ZUSAMMENLAUFEN