



YAS
AGE



GERI DÖNÜŞÜM
RECYCLE



EMEKLEME
CRAWLING



SALINIM
ROCK



TIRMANMA
CLIMBING



DÜŞME YÜKSEKLİĞİ
FALL HEIGHT



KAPASİTE
CAPACITY

Cemer®

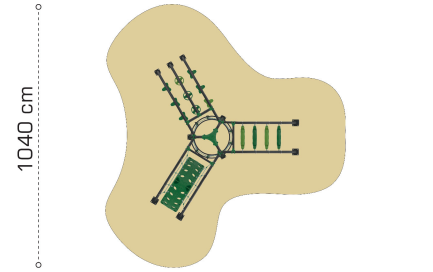

1040 cm

950 cm

GÜVENLİK ALANI
SAFETY AREA



740 cm

YAN GÖRÜNÜŞ
SIDE VIEW

ZEMİN ÇİZGİSİ
GROUND LINE

650 cm



200 cm

ÖN GÖRÜNÜŞ
FRONT VIEW

ZEMİN ÇİZGİSİ
GROUND LINE

300 cm

300 cm



YAŞ
AGE



GERİ DÖNÜŞÜM
RECYCLE



EMEKLEME
CRAWLING



SALINIM
ROCK



TIRMANMA
CLIMBING



DÜŞME YÜKSEKLİĞİ
FALL HEIGHT



KAPASİTE
CAPACITY

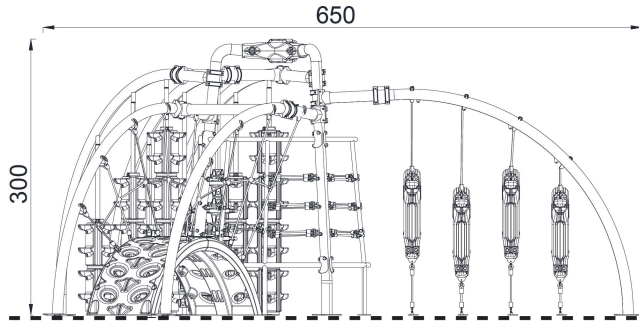

ÖN GÖRÜNÜŞ / FRONT VIEW

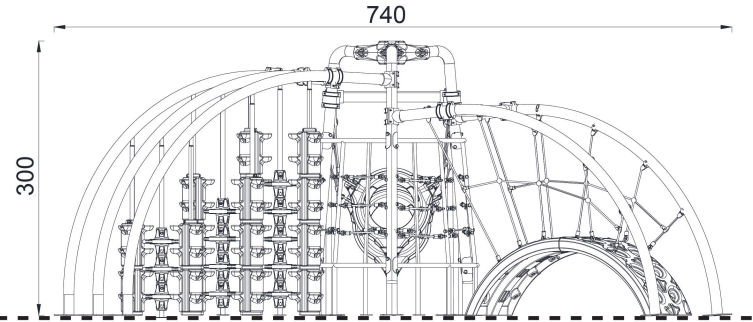

YAN GÖRÜNÜŞ / SIDE VIEW

ZEMİN ÇİZGİSİ / GROUND LINE

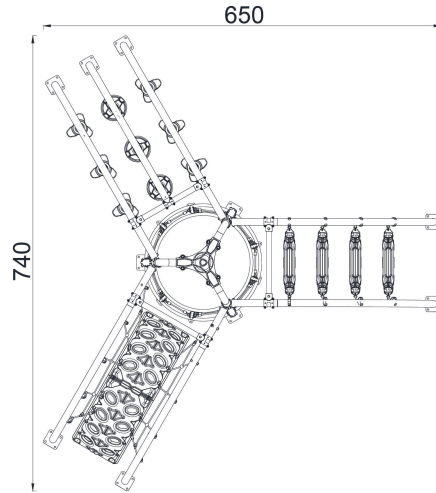

ÜST GÖRÜNÜŞ / TOP VIEW

Product Specification "Metal Series"

Main Mast (Post):



- Metal masts and other metal parts (Wherever available) are made of ST37 steel.
- Metal finish consists 3-layer execution,
 - Shot Blasting
 - Zinc-Rich Primer Coating
 - Powder Coating
- Products within the range are designed to fix ground via square flanges.

Polyethylene Parts:



- Rotomolded polyethylene (LLDPE) and manufactured in aluminum molds in double walls. The wall thickness of polyethylene parts is between 4-6 mm.
- Polyethylene is fire retardant and strengthened against UV.
- Hardcovers are injection molded.
- Polyethylene is fire retardant and strengthened UV protected.

High-Density Polyethylene Sheets:



- 15-19 mm dual color triple layer high-density polyethylene sheets (HDPE) are used in this range.
- HDPE sheets are formed with CNC and router machines for precise dimensions.
- HDPE is fire retardant and strengthened UV protected.
- Anti-skid 19 mm HDPE is used for the surface of DGSS 26 and DGSS 27.

Armed Rope:



- Own production 16 mm. Diameter polyamide 6 (nylon) and braided armed ropes are used to construct net climbing accessories in the product group.
- Each armed rope has 6 strands, and these strands are built on a core. Each strand is built with braided polyamide on steel wires. The core of the rope can either fiber or steel depending on the loading requirement.
- Breakpoints ropes mentioned above are as follows.

16 mm. FC	3980 Kgs.	16 mm IWRC	5820 Kgs.
-----------	-----------	------------	-----------

- Note: FC (Fiber Core) IWRC (Steel Core)
- Armed ropes have UV resistance and Flame Retardancy.

Swing Seats:



- Toddler seats are made of rotational molding polyethylene and coated with rubber shock absorbers.
- Bird nest seats are manufactured from a particular type of polyethylene which is a shock absorber itself with its unique design.
- Hemp Rope swing is made of 14 cm thick with steel reinforcement inside.

Platform

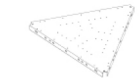

- Platforms are made of ST37 metal Sheets and dipped into plastic for further protection of users.

Ball Bearing System:



- The system is located in 5" and 6" pipes.
- Working principle depended on having the lower body stable and fixed while upper body allows the equipment spin.

- Ball bearing system is connected upper and lower body by 12 mm bolts.
- In radial movement system two conic ball bearings shall be used, to lock the system counter nuts and tab nuts shall be used.
- All system is stainless steel
- System speed is adjustable.
- For smaller systems, the small version steel bearing system is used. (C-SS 67, C-SS 52 and DGSS 01)

Torsion:

- For balance equipment, Rosta™ torsions are used.

Connectors:



- Stainless Steel connectors are used at rope ends where rope element fixed to the primary structure.
- Polyamide connectors are used to combine armed ropes.
- Aluminum Cast connectors are also used at rope ends where rope element fixed to the metal frame.
- The patented functional connector provides multi-connection to masts. Steelwork is covered with aluminum and polyamide.

Bolts and Nuts:

- All bolts, nuts washers are stainless steel or coated with DACROMET® due to size and use.

General Notes

- $\pm 5\%$ deviation may occur in the size and weight of products within the range.
- CEMER keeps rights to make any technical and price changes