

300 mm high box for low jumps. The box can be used for either high-speed jumps or slower stepping. Jumping raises the heart rate and strengthens the leg muscles and bones. Box squats, where one lowers oneself to sitting on the lowest possible box, are excellent for those with knee trouble. Keep the weight on the heels, with the lower leg as vertical as possible and pushing the knees outward at all times. The box can also be used for raised push-ups and dips.

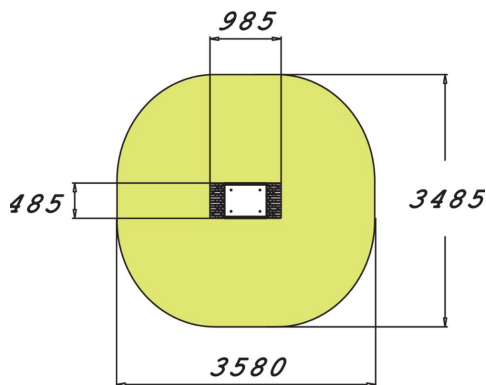
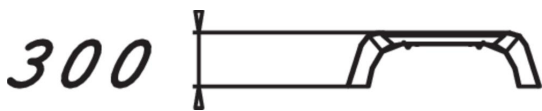

Product length, mm	985
Product width, mm	485
Product height, mm	300
Max. free fall height, mm	300
Safety info	EN 16630, EN 1176-1 TÜV
Installation time (for 1), H	1
Foundation options	Deep mounting Surface mounting