

1:125

1:125

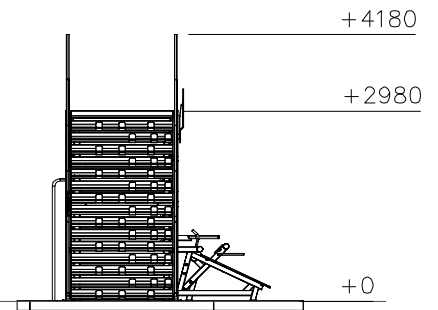

Concrete

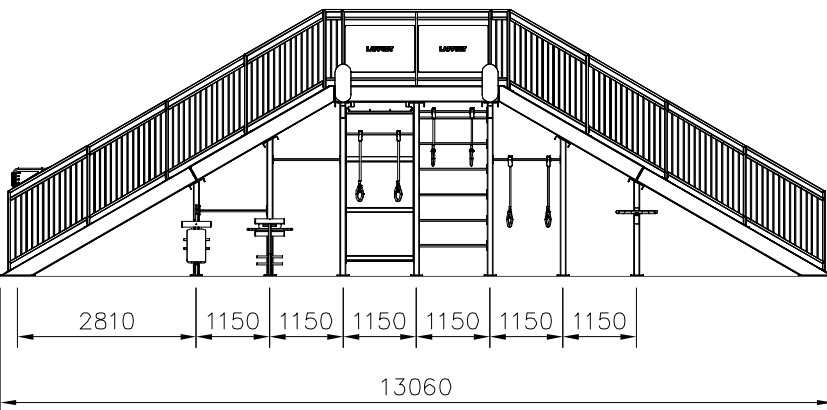
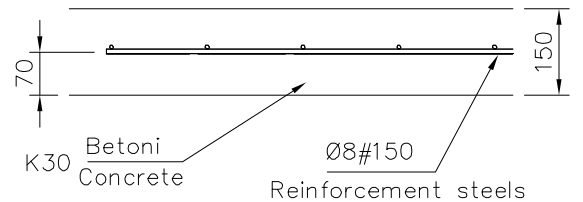

- Area of Movement 81 m<sup>2</sup>      Max Falling Height 2980 mm
- - - Movement Space 90.8 m<sup>2</sup>
- Training Space 31.7 m<sup>2</sup>

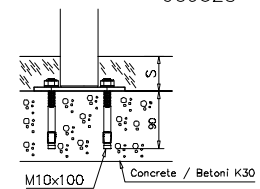
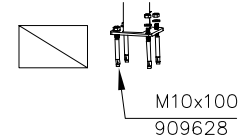
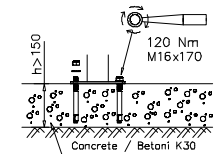
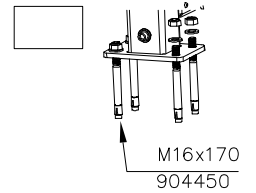
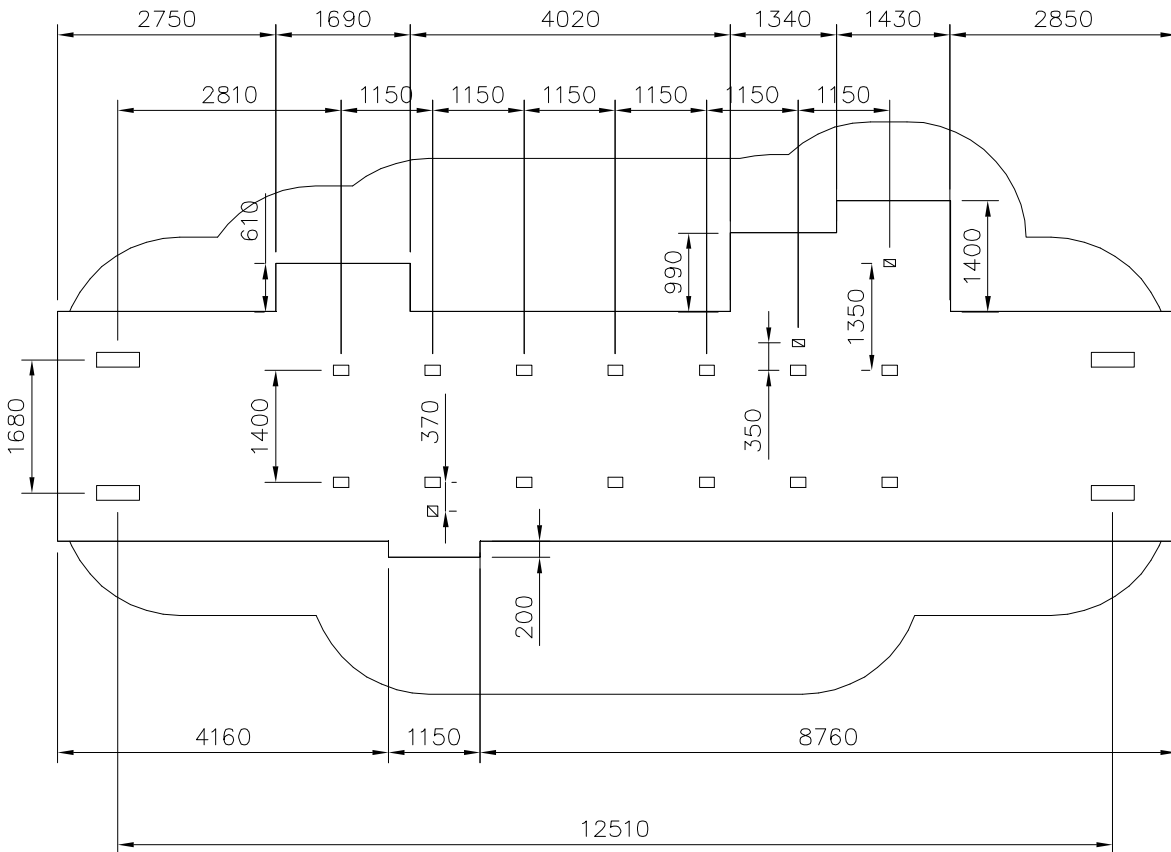
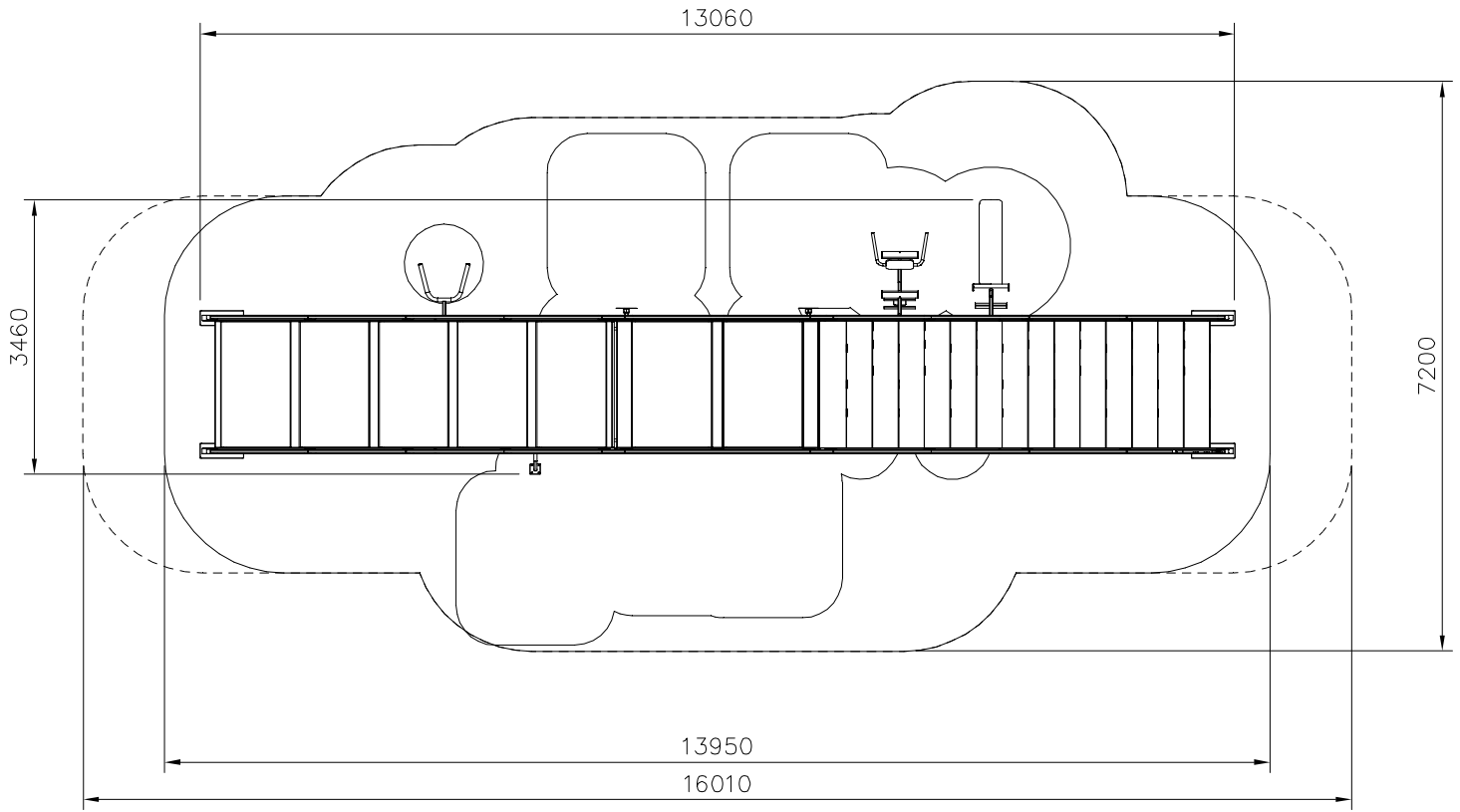

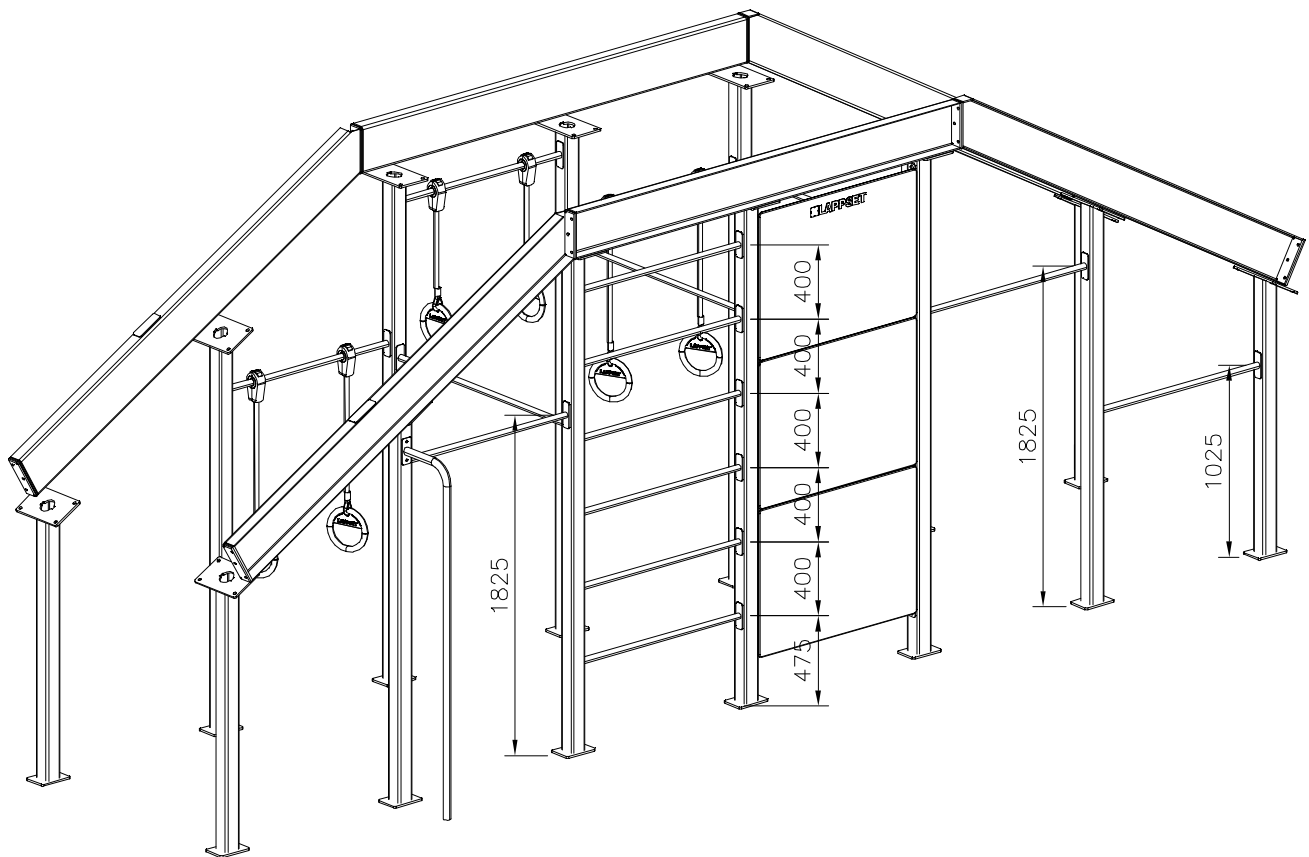
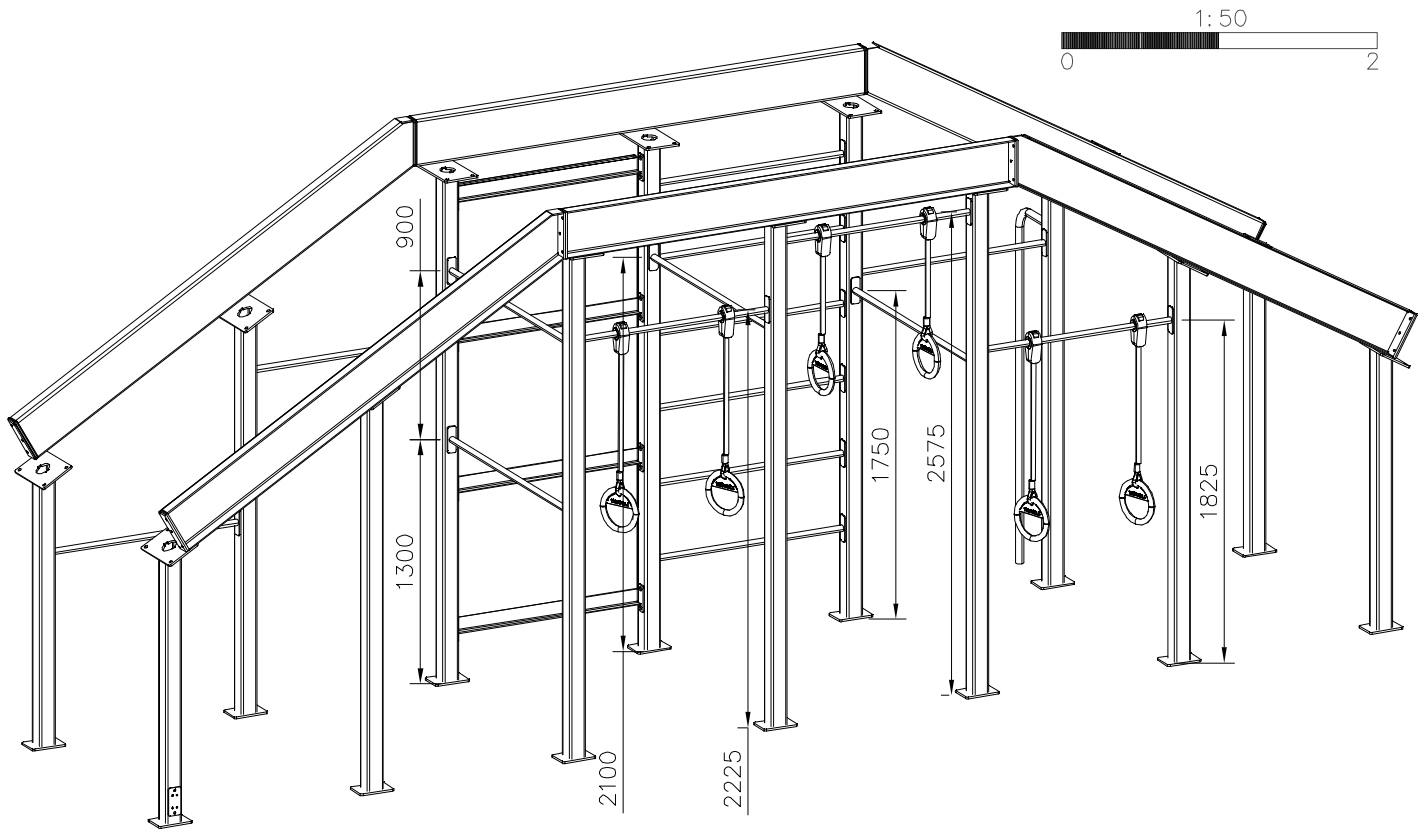

## SISU FITNESS STAIRS

### INSTALLATION MANUAL

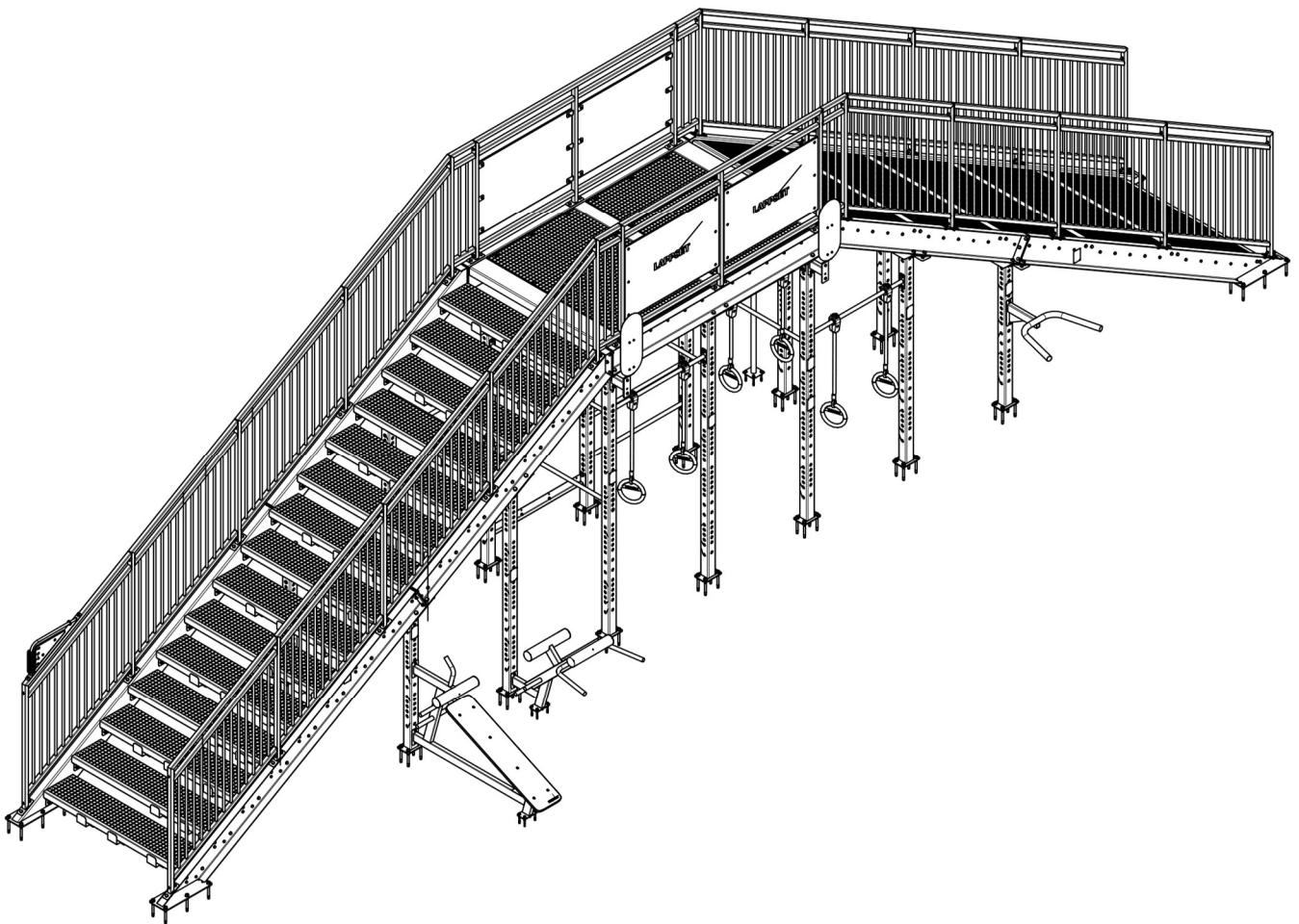

**081873M**

## SISU FITNESS STAIRS

### PART LIST & FASTENING ACCESSORIES

ITEM NO.	PART NUMBER	DESCRIPTION	QTY.
1	709733	SIGN, PULLUP	1
2	709734	SIGN, DRAGON FLAG	1
3	709735	SIGN, GIANT	1
4	709738	SIGN, HANDWALK	1
5	709739	SIGN, BALLWALL	2
6	709741	SIGN, RINGSROW	1
7	710040	SIGN,PULLUP	1
8	710483	SIGN, SIT-UP	1
9	710484	SIGN, BACK EXTENSION	1
10	710485	SIGN, DIP	1
11	711404	SIGN, HUMAN FLAG	1
12	712320	LAMINATE	4
13	712464	ROPE ELEMENT	4
14	712467	ROPE ELEMENT	2
15	712495	LAMINATE	2
16	712496	LAMINATE	1
17	713397	SIGN, RAMP	1
18	713398	SIGN, STAIRS	1
19	713411	PRODUCT SIGN	1
20	900965	CAP NUT, M10, DIN 986, nyloc rst	158
21	901302	WASHER, (M10), DIN 125, A2	140
22	902195	CLAMP	12
23	902232	ALLEN SCREW, M10x55, A2 + 2 X DELTA GZ	6
24	902233	ALLEN SCREW, M10x30, A2 + 2 X DELTA GZ	6
25	903148	BOLT, M16 x 50, KS, DIN 931 8,8	56
26	903149	BOLT, M12 x 30, KS, DIN 931 5,8	148
27	903158	LOCK NUT, M16, DIN 985, nyloc zn	56
28	904450	ANCHOR, M16x170	80
29	905827	ALLEN SCREW, M8 x 20	180
30	906006	SLEEVE	12
31	906598	STICKER	1
32	909248	LOCK NUT, M12, DIN 985, nyloc zn	172
33	909256	WASHER, (M8), DIN 125, A2	360
34	909349	BOLT, M12 x 40, KS, DIN 601 4,6	24
35	909520	WASHER, (M16), DIN 125, A2	112
36	909628	ANCHOR, M10x100	12
37	909629	BOLT, M10 x 30, KS, DIN 933 8,8	130
38	909633	CAP NUT, M8, DIN 986, A2, nyloc rst	238
39	909637	LOCK NUT, M10, DIN 985, nyloc zn	128
40	909638	WASHER, (M10), DIN 125, HDG	331
41	909854	COUNTERSUNK SCREW, M8x50 A4	6
42	910376	BUSHING, Ø30x17	171
43	910416	INSIDE PLUG, Ø48/43-45x23	2
44	910455	SUPPORT	1

## SISU FITNESS STAIRS

45	910604	SUPPORT PIECE	4
46	911149	ALLEN SCREW, M10 x 110	91
47	911837	METAL FRAME	1
48	911843	METAL FRAME	1
49	912180	SPECIAL SCREW, Ø8 x 60 delta	70
50	912500	RIVET, Ø4,8x14	60
51	912515	DIP BAR	1
52	912575	COUNTERSUNK SCREW, M8x110 A4	2
53	914571	STAIRS	1
54	914574	FRAME ASSEMBLY	1
55	914579	SUPPORT	7
56	914583	FRAME ASSEMBLY	1
57	914584	FRAME ASSEMBLY	1
58	914585	FRAME ASSEMBLY	1
59	914588	POST	4
60	914590	POST	4
61	914595	POST	6
62	914596	SUPPORT	5
63	914597	SUPPORT	2
64	914598	SUPPOR	14
65	914635	FRAME ASSEMBLY	1
66	914636	FRAME ASSEMBLY	1
67	914637	FRAME ASSEMBLY	1
68	914638	FRAME ASSEMBLY	1
69	914700	HANDRAIL	4
70	914720	HANDRAIL	16
71	914735	GRID	7
72	914743	TUBE ASSEMBLY	2
73	914746	BAR ELEMENT	4
74	914747	BAR ELEMENT	12
75	914751	TUBE ASSEMBLY	15
76	914753	BRACKET	45
77	914777	STEP	15
78	914819	FASTENER	70
79	914885	ALLEN SCREW, M10 x 60	50
80	914904	COUNTERSUNK SCREW, M8x25 A2	50
81	915360	COVER	4
82	915361	COVER	1
83	915409	SUPPORT	2
84	915416	COUNTER	1
85	915473	FRAME ASSEMBLY	2
86	915475	HANDRAIL	2
87	980151	WASHER, (M8), DIN 125, HDG	58
88	980154	WASHER, (M12), DIN 125, HDG	344
89	914838-213	SIGN, YELLOW	15
90	914838-241	SIGN, BLUE	15
91	914838-260	SIGN, RED	15

**SISU FITNESS STAIRS**

92	M99452	ALLEN SCREW, M10 x 30	4
----	--------	-----------------------	---

## SISU FITNESS STAIRS

### STAIRS (1 PC)

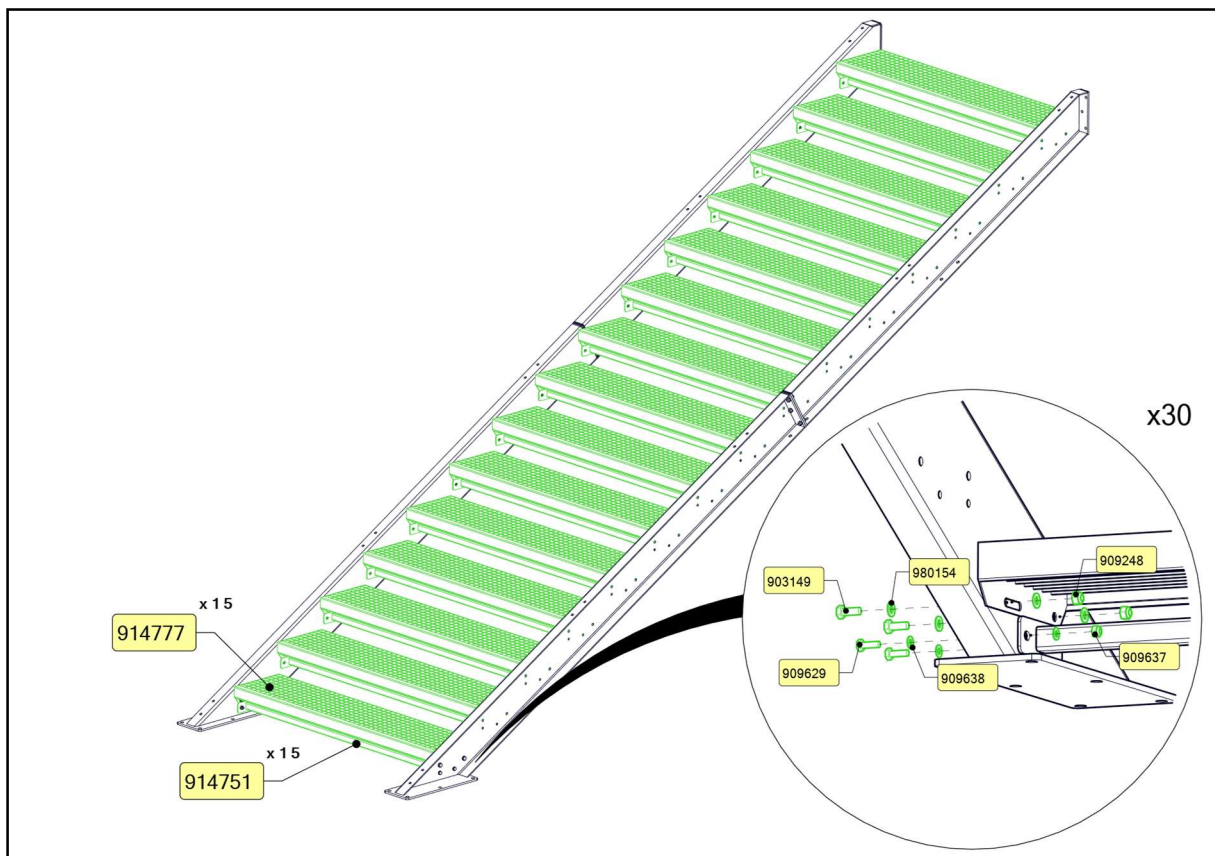
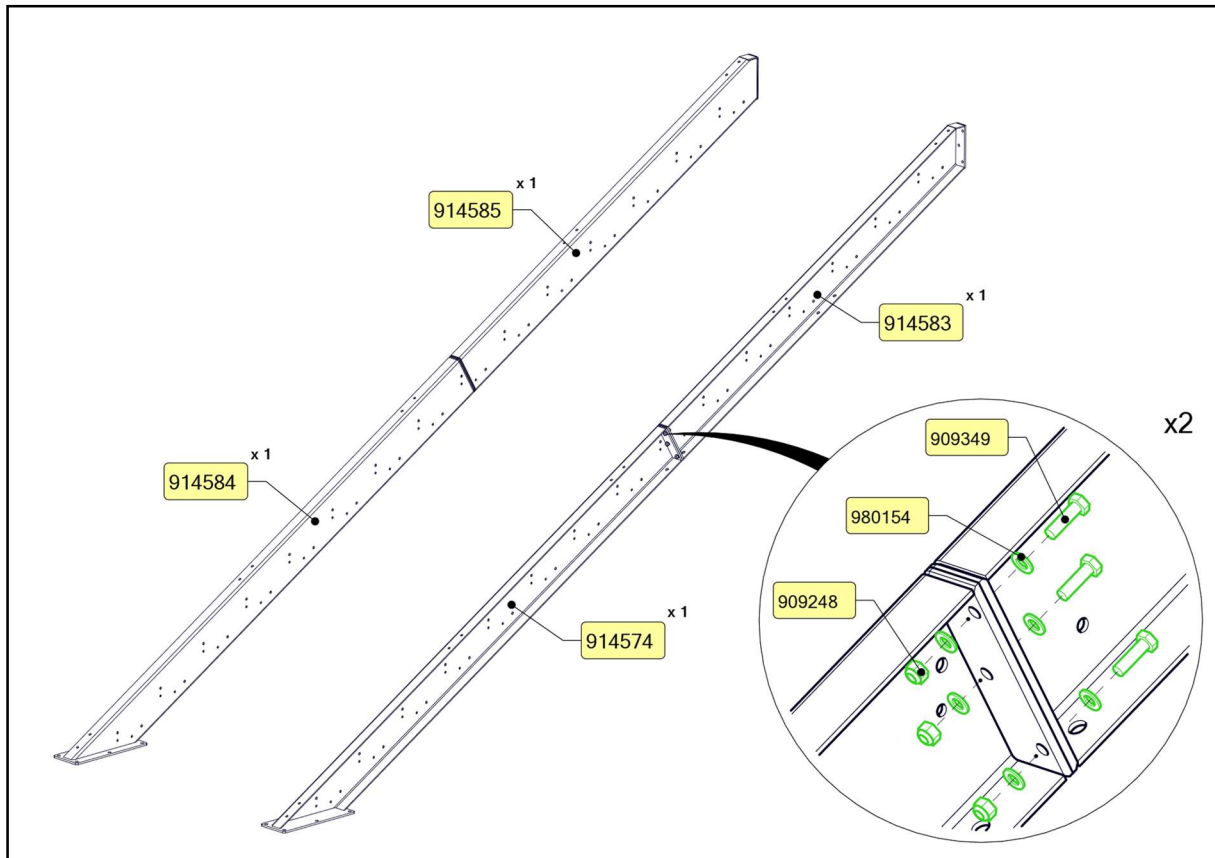

## SISU FITNESS STAIRS

### STAIRS (1 PC)

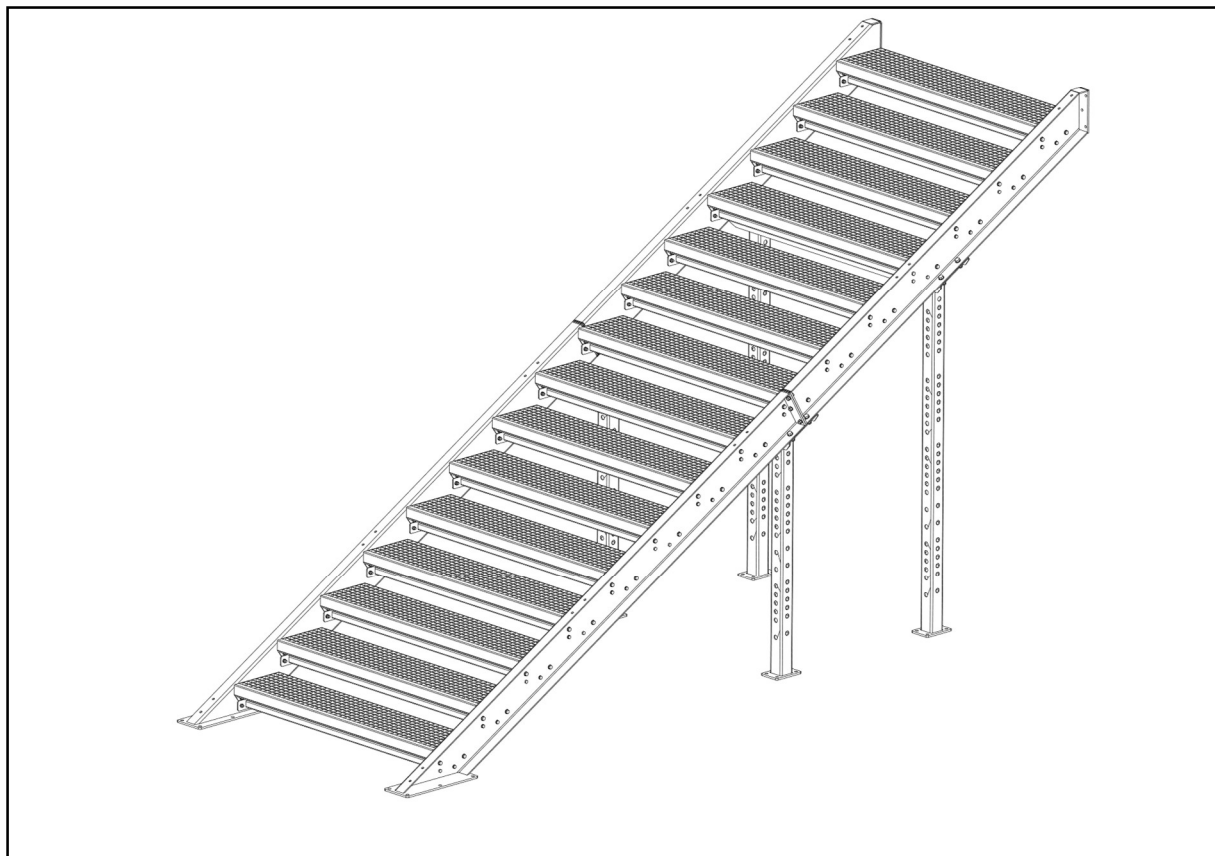
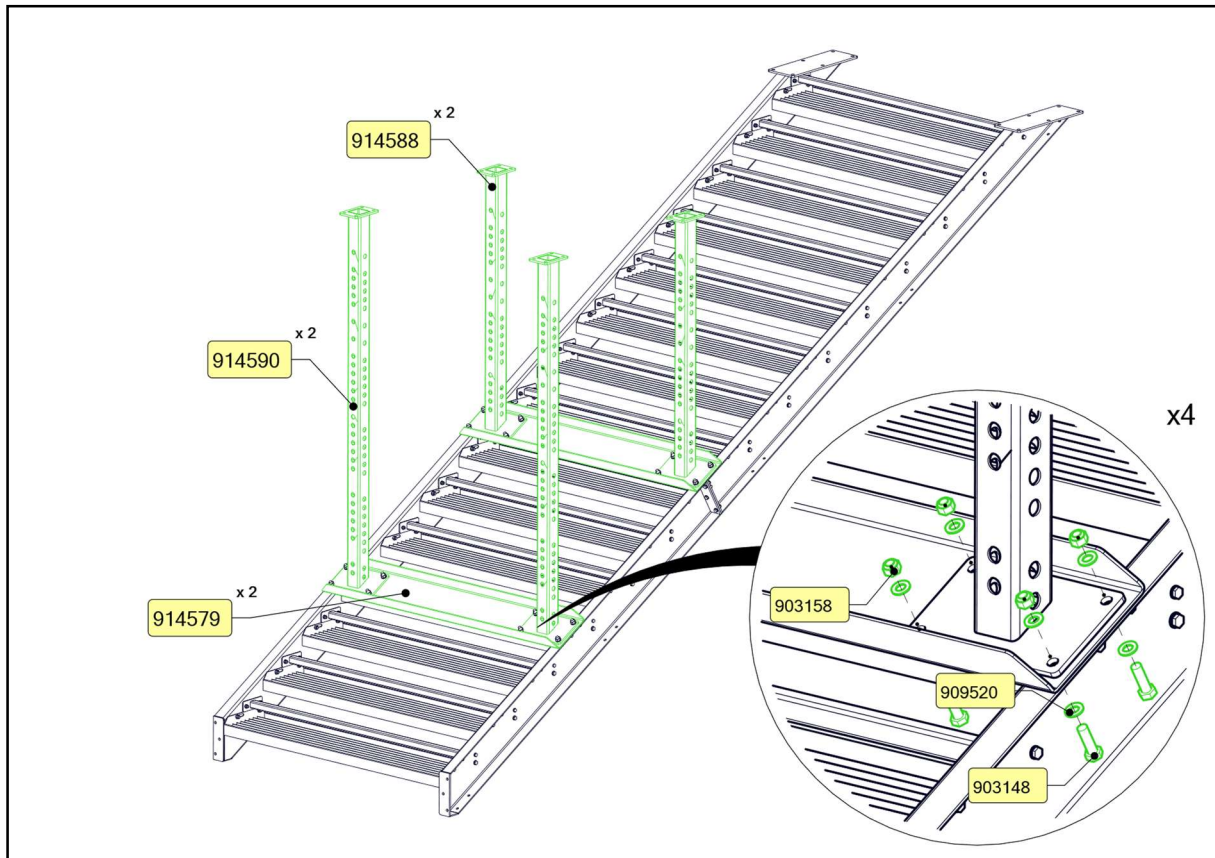

## SISU FITNESS STAIRS

### RAMP (1 PC)

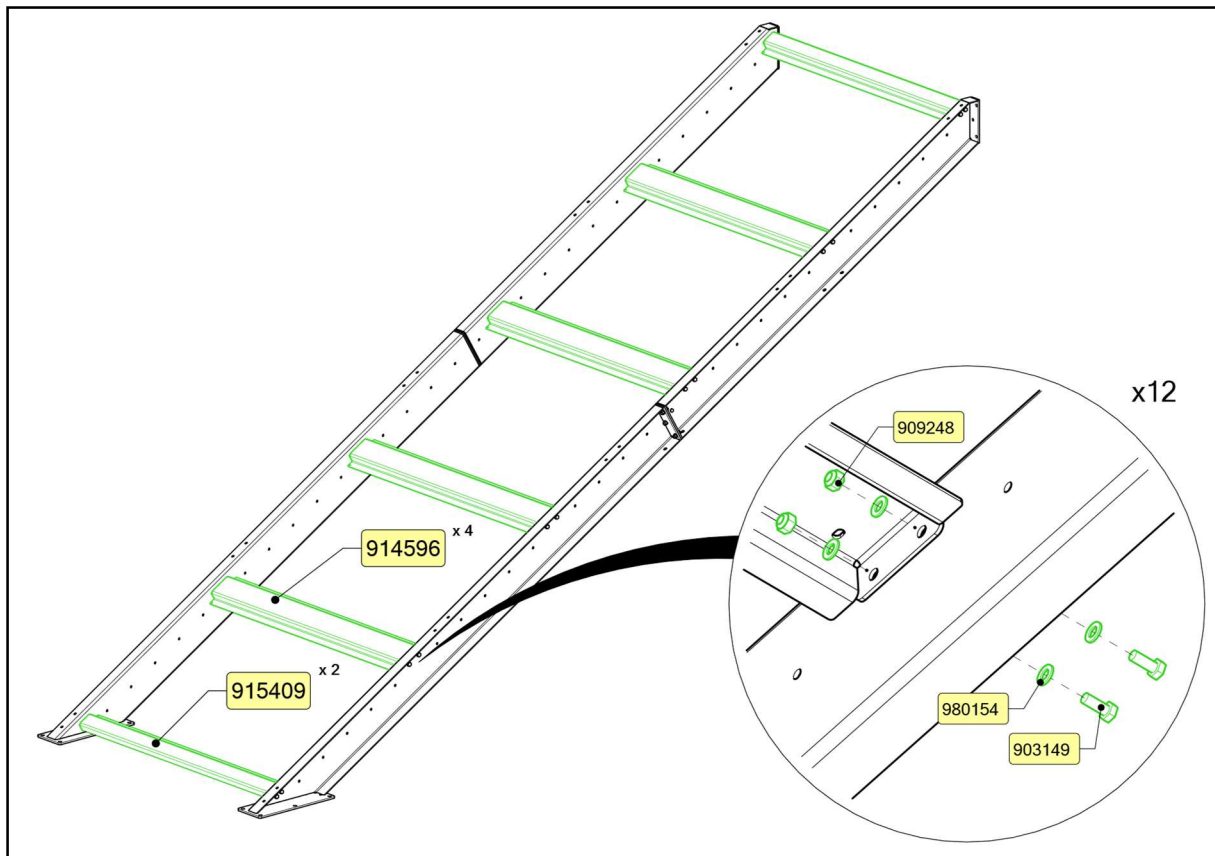
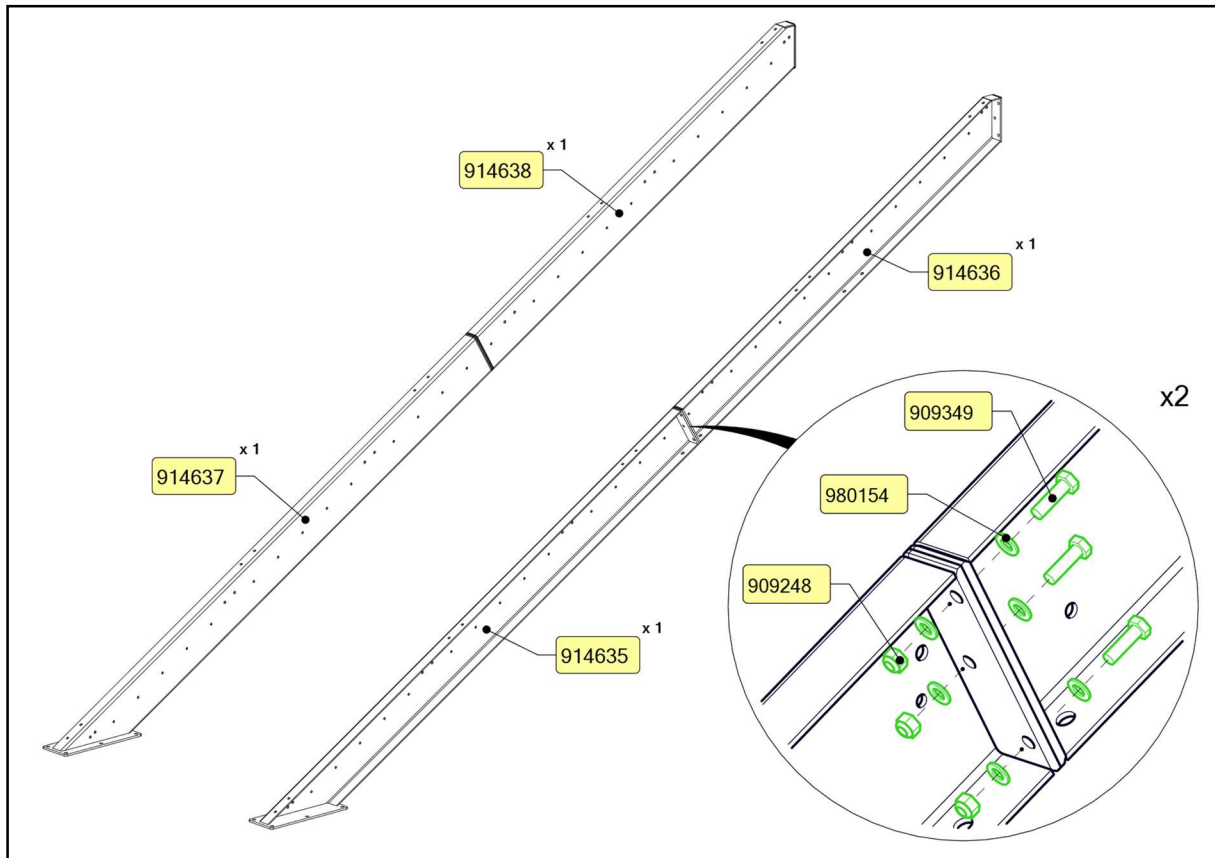

## SISU FITNESS STAIRS

### RAMP (1 PC)

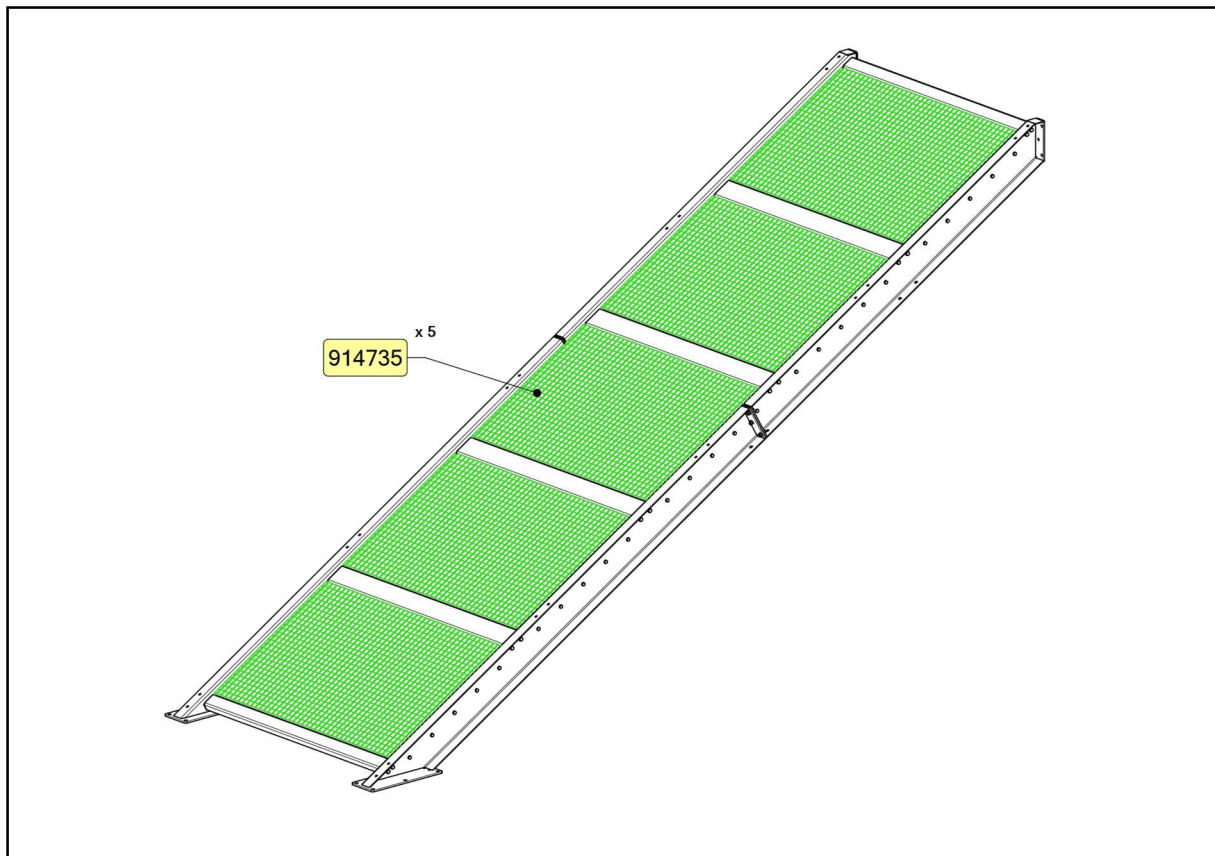
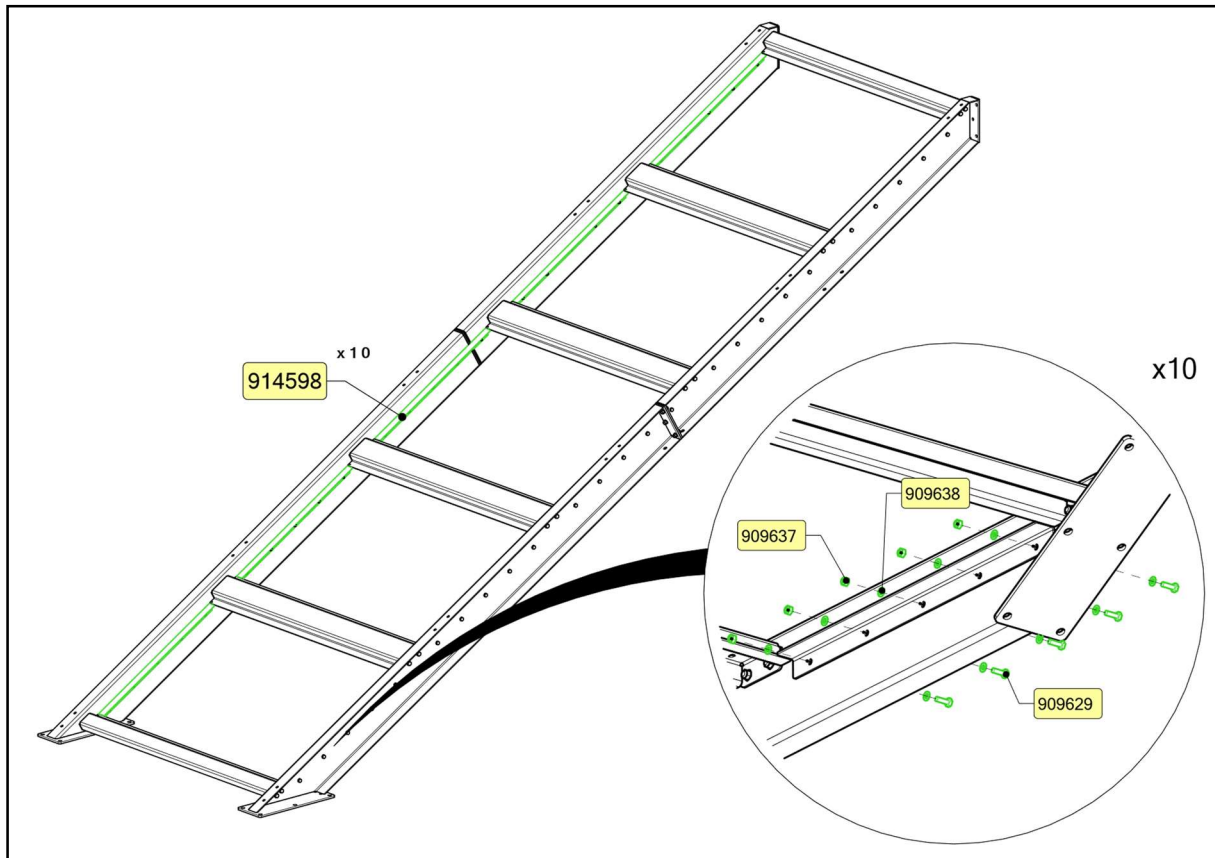

## SISU FITNESS STAIRS

### RAMP (1 PC)

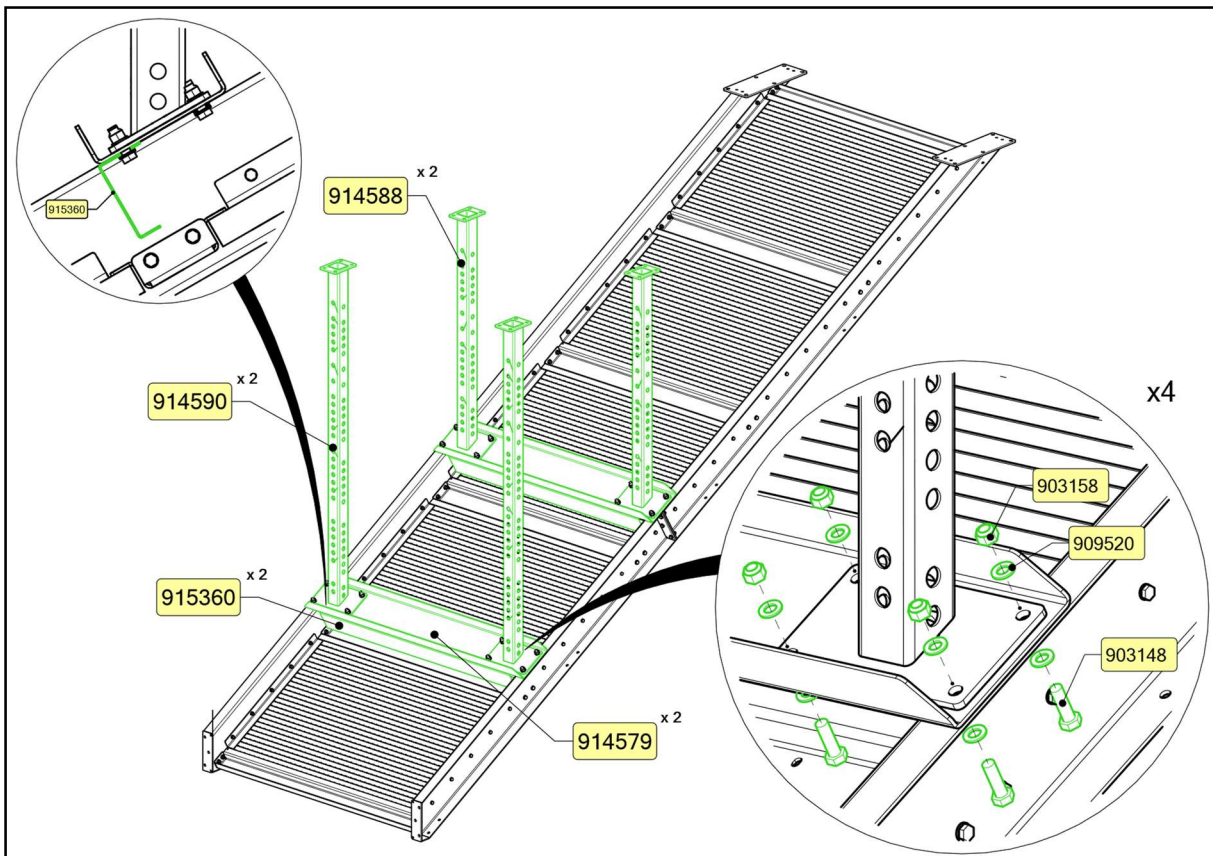
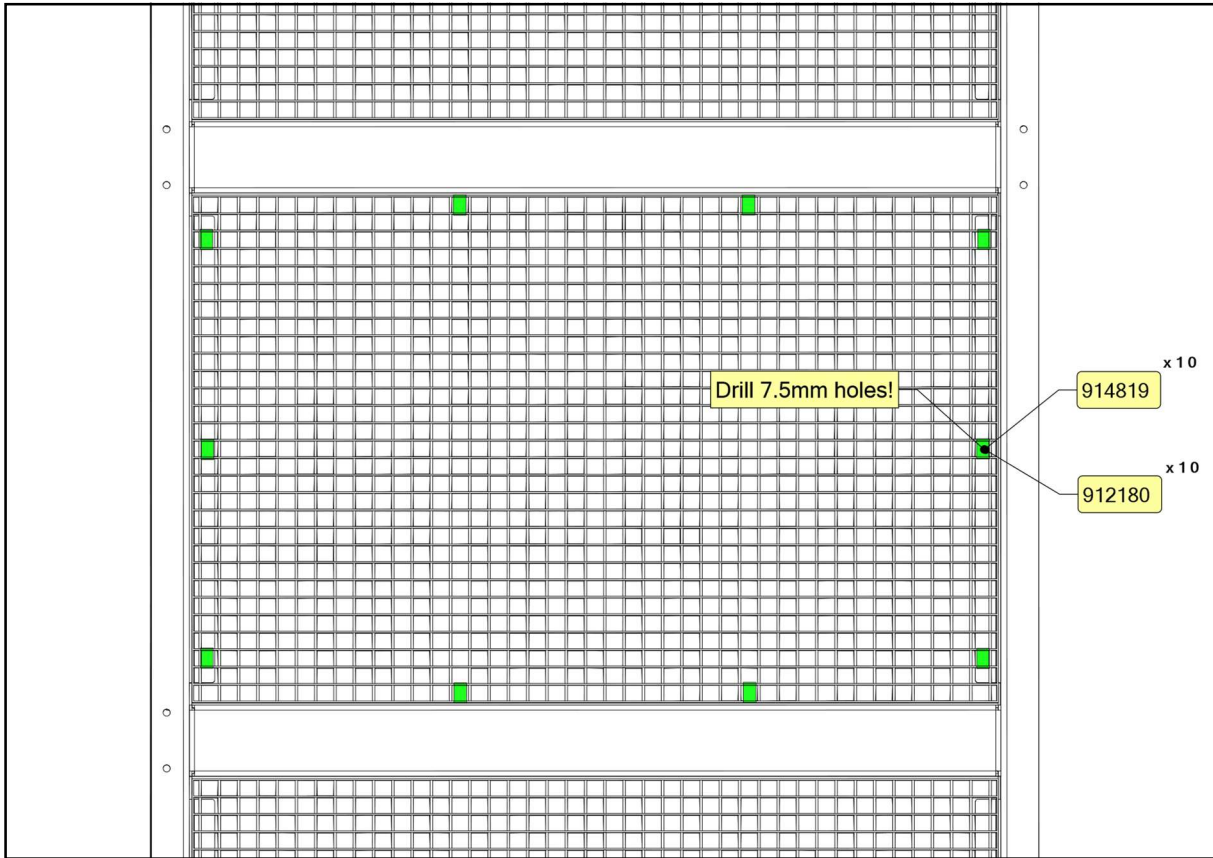

## SISU FITNESS STAIRS

### RAMP (1 PC)

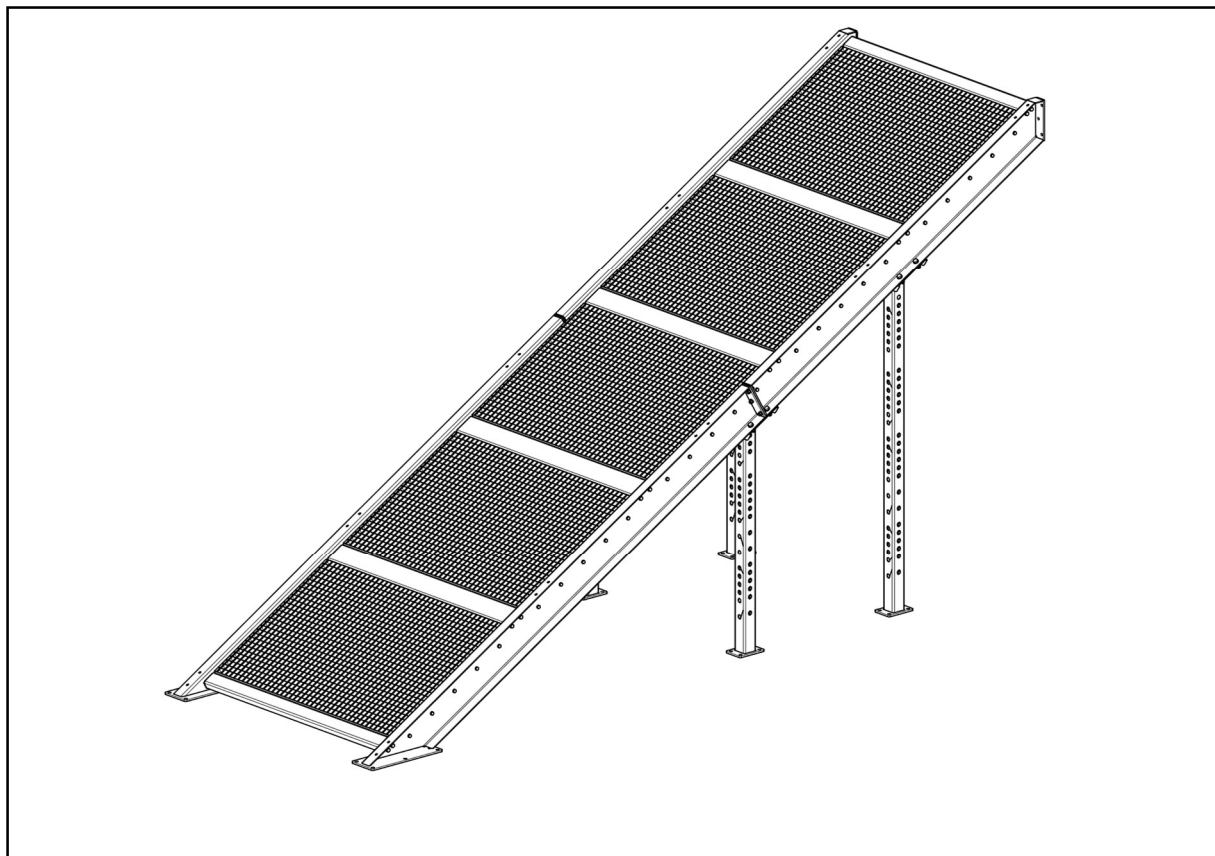
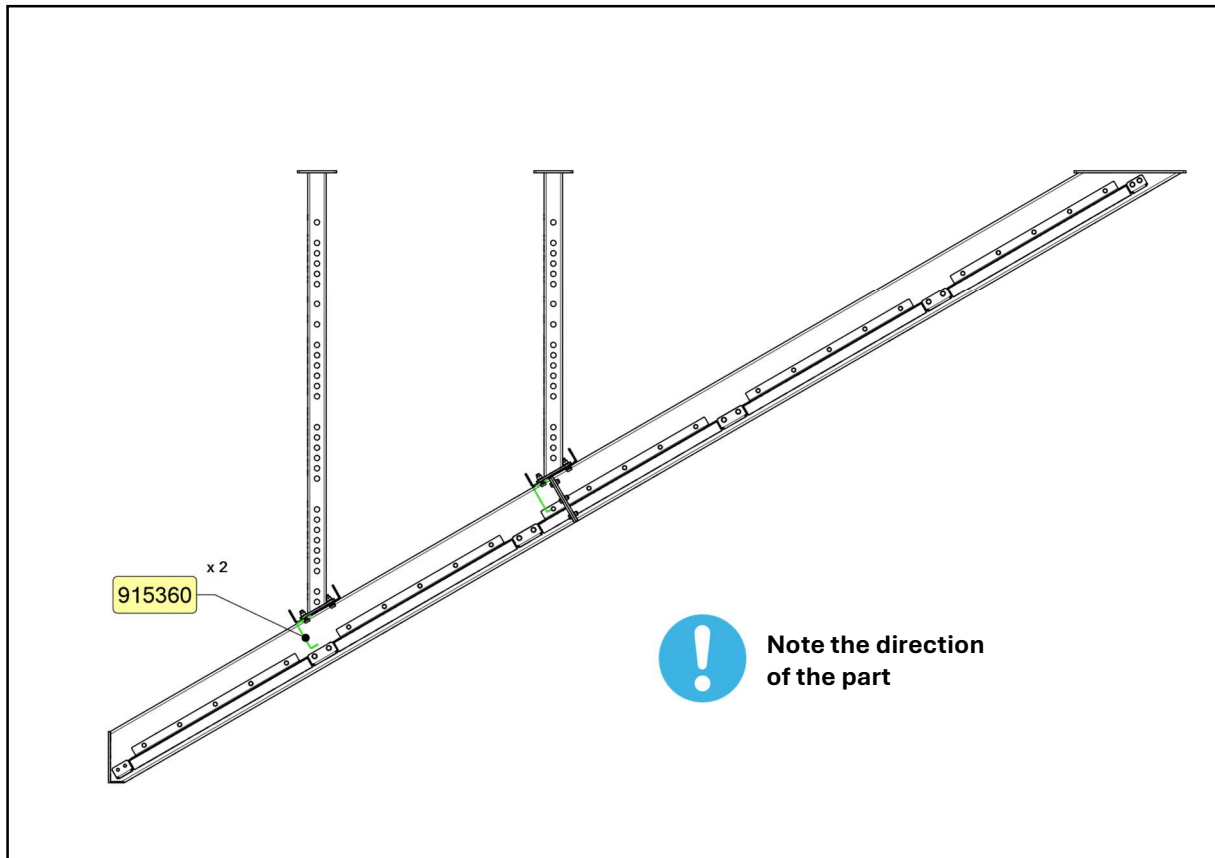

## SISU FITNESS STAIRS

### FLOOR (1 PC)

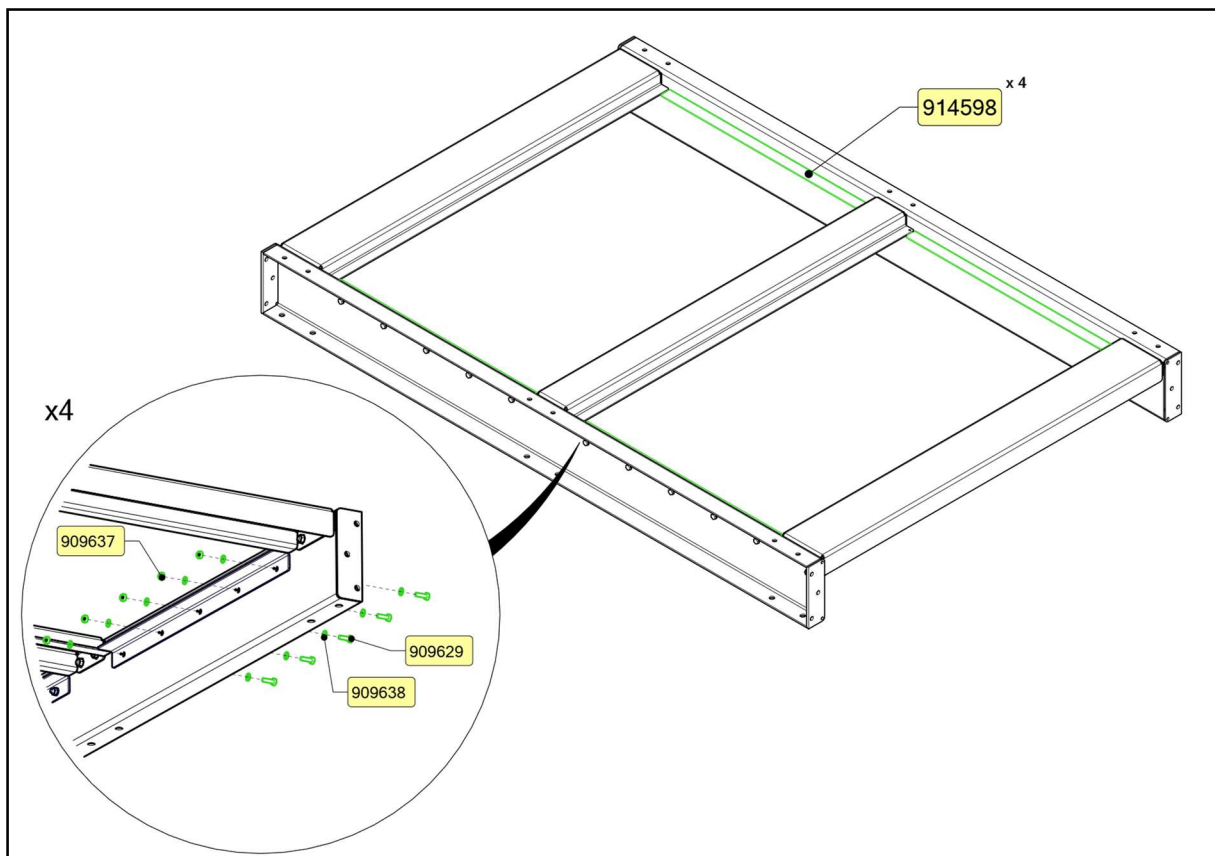
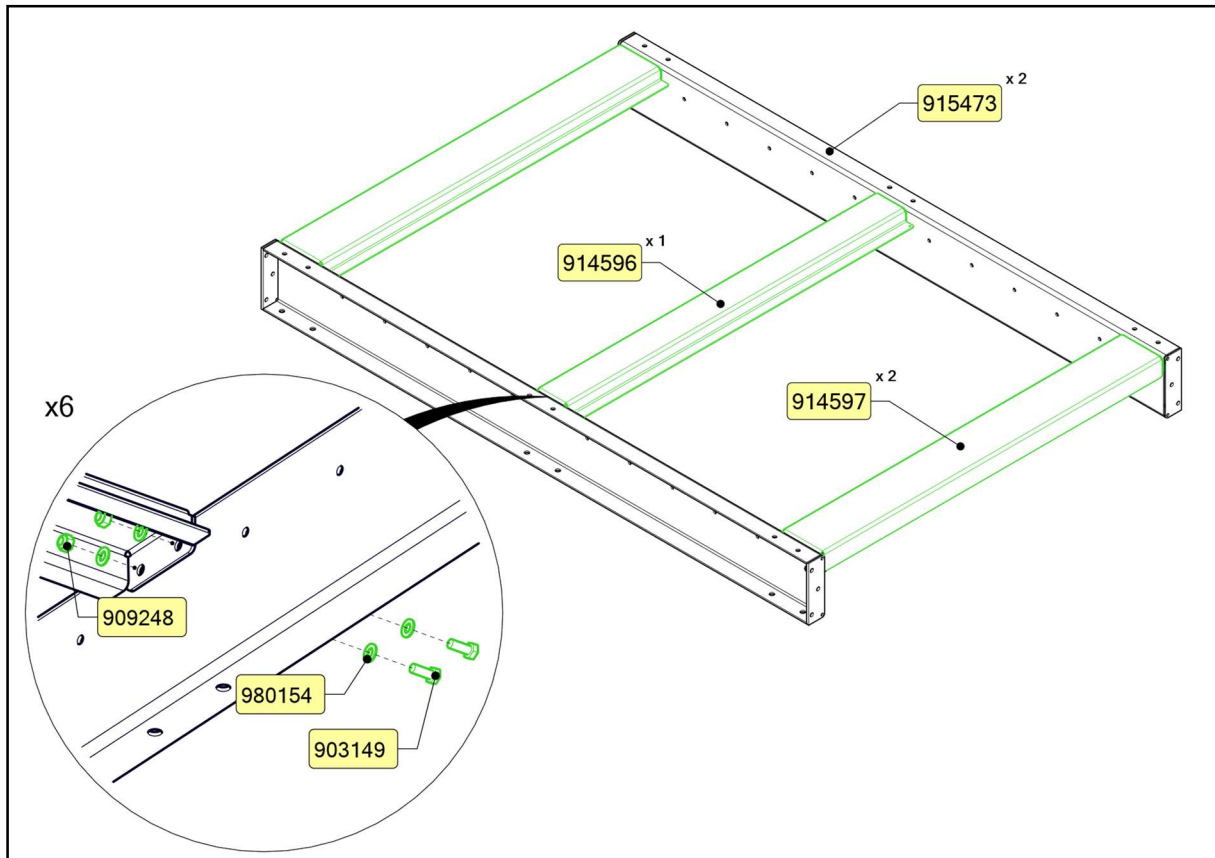

## SISU FITNESS STAIRS

### FLOOR (1 PC)

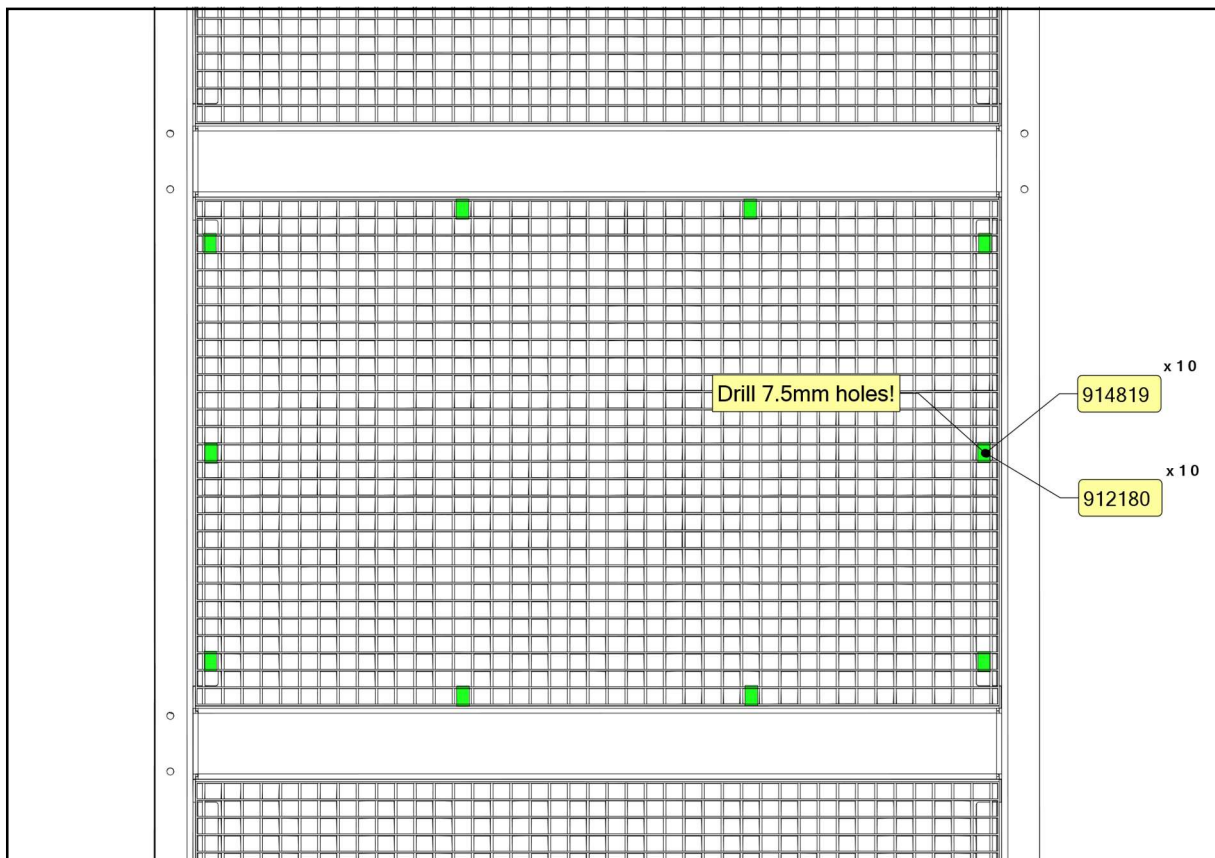
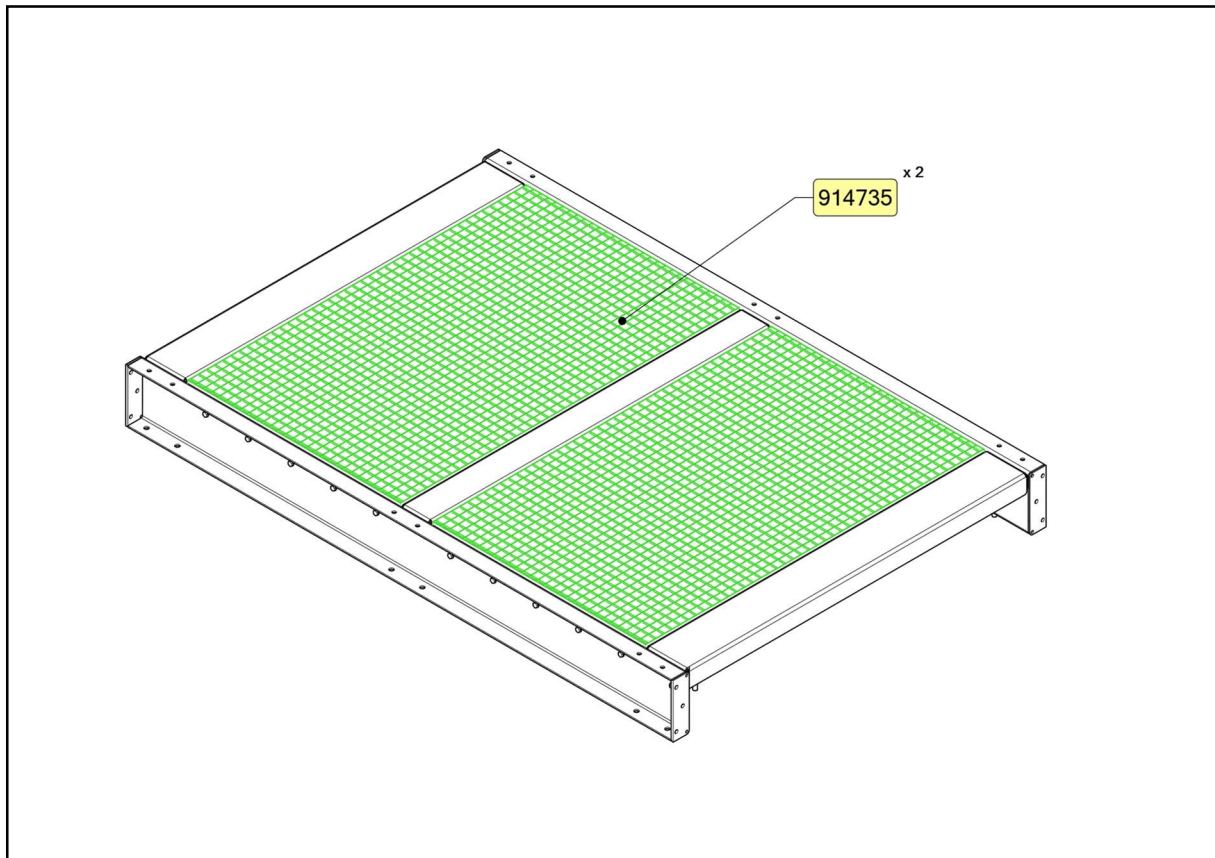

## SISU FITNESS STAIRS

### FLOOR (1 PC)

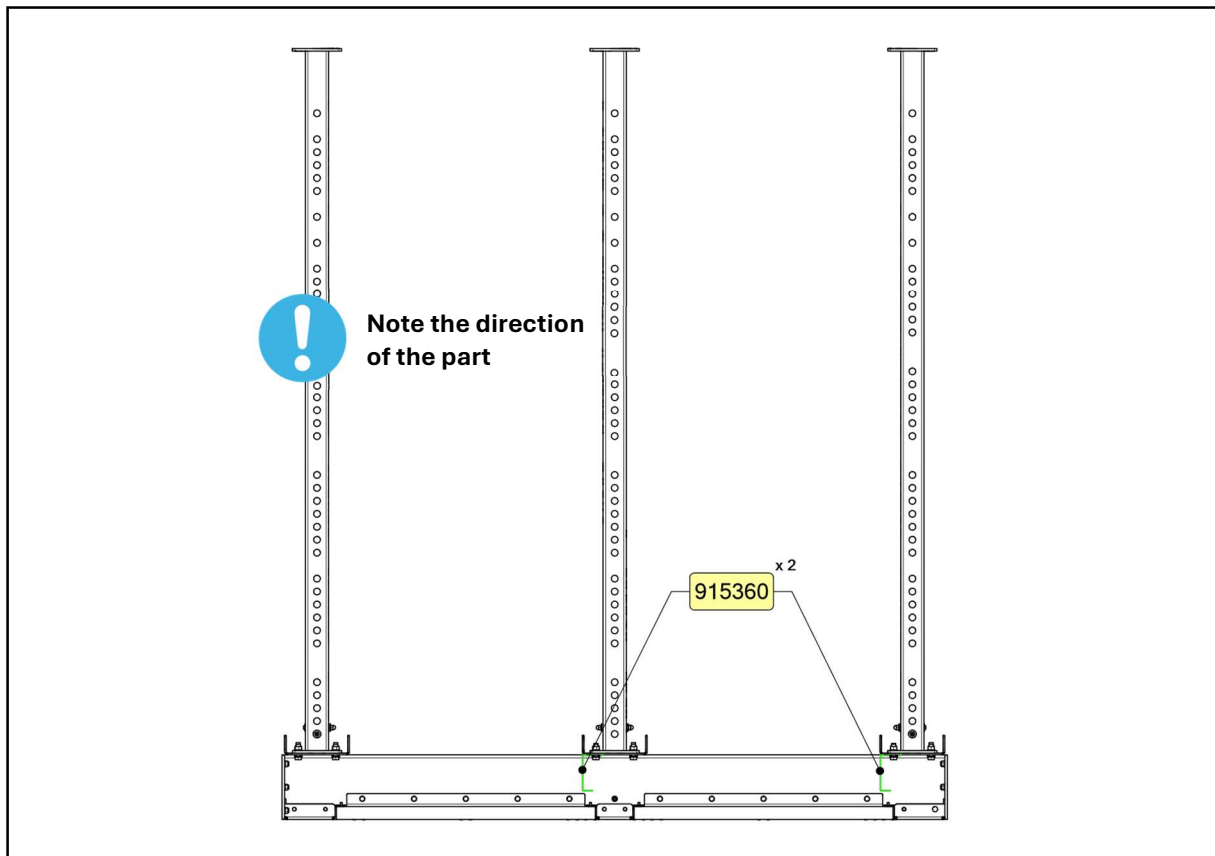
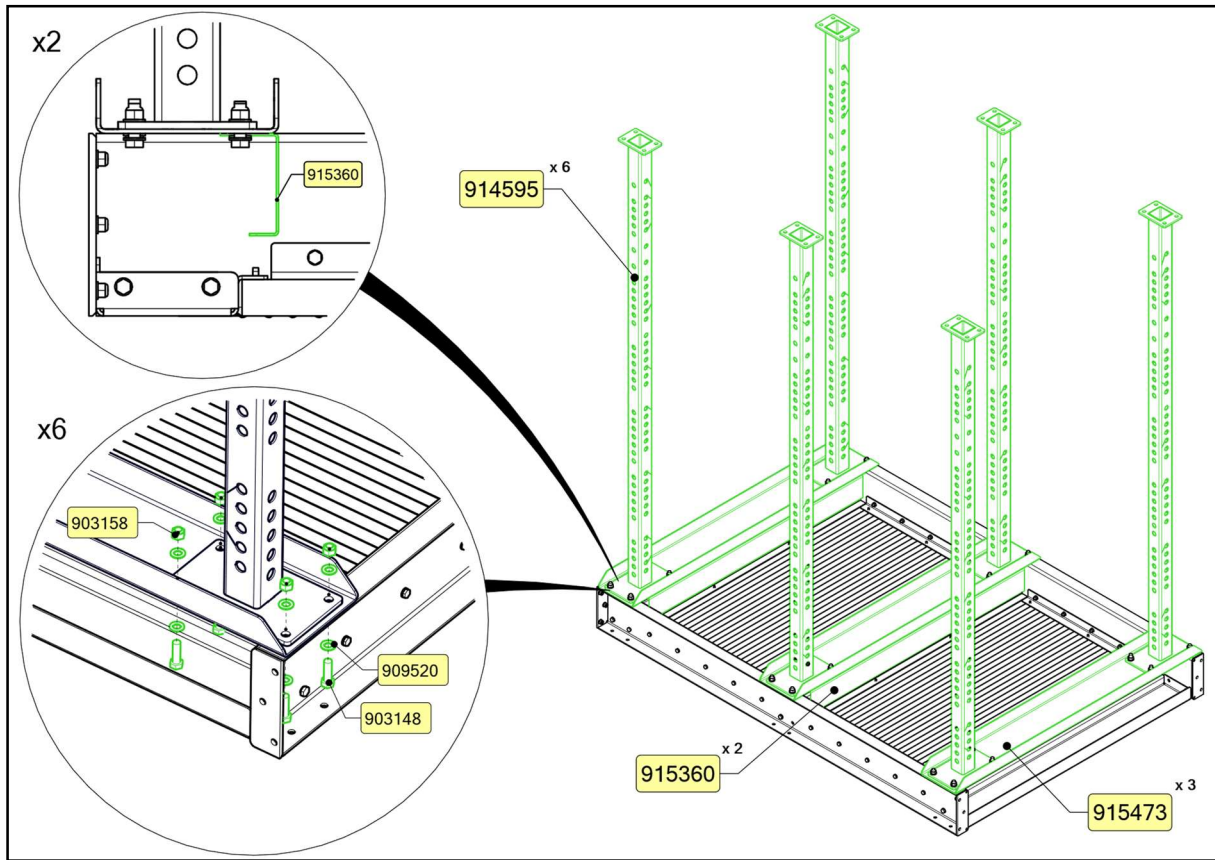

**SISU FITNESS STAIRS**

**FLOOR (1 PC)**

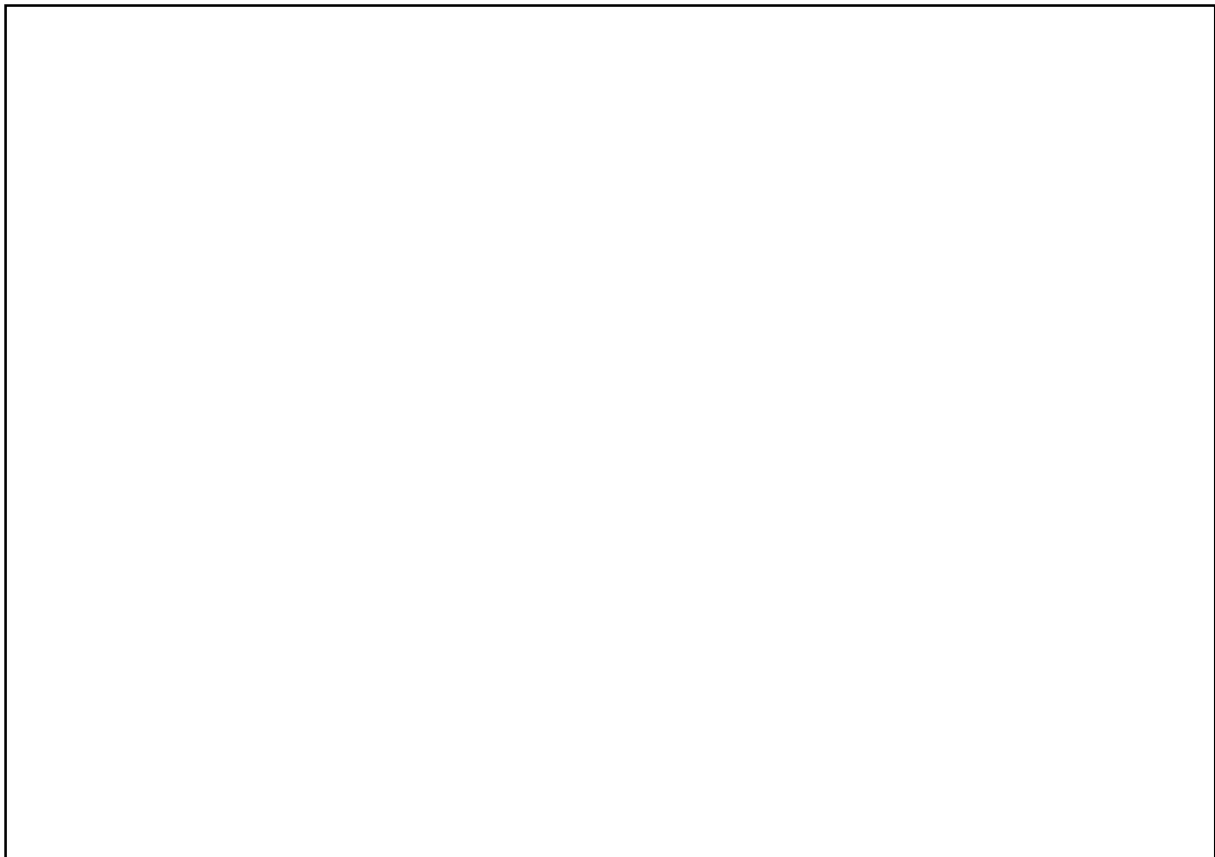
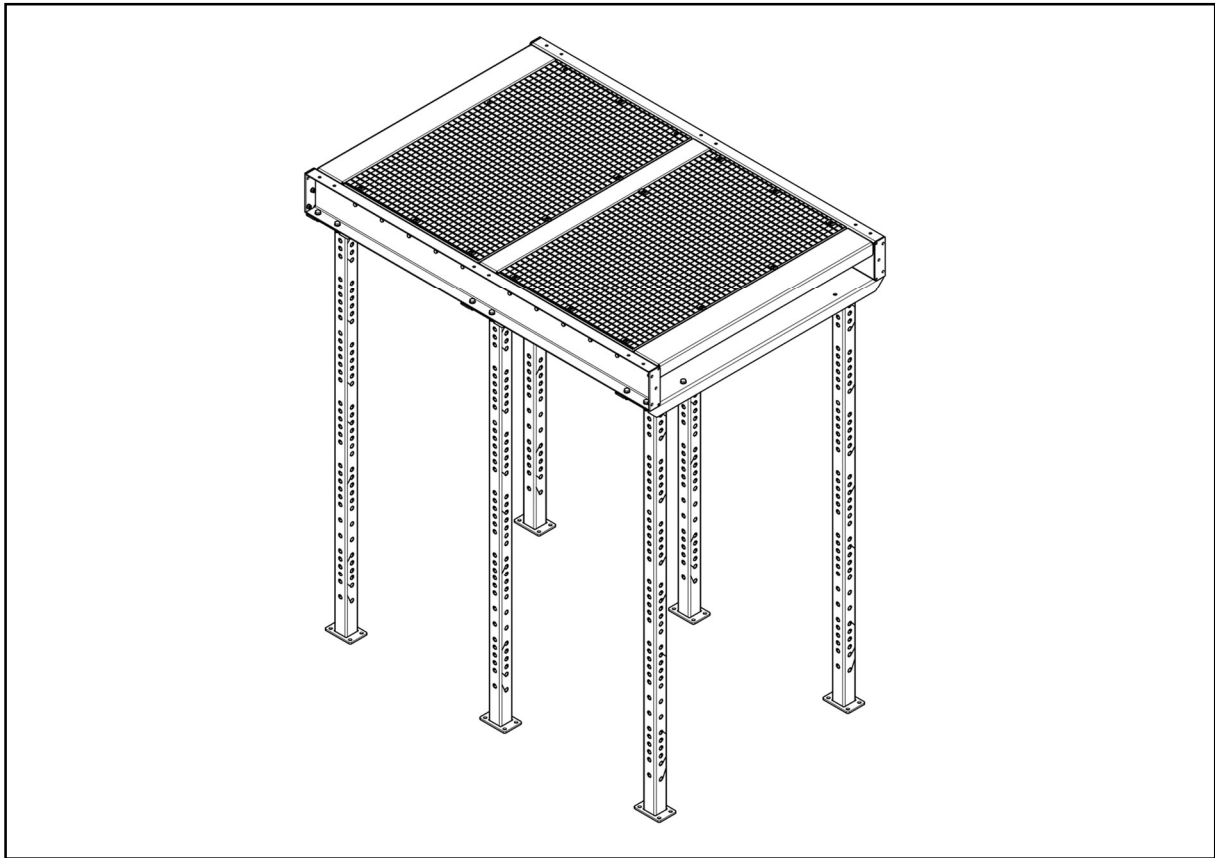

## SISU FITNESS STAIRS

### ASSEMBLY

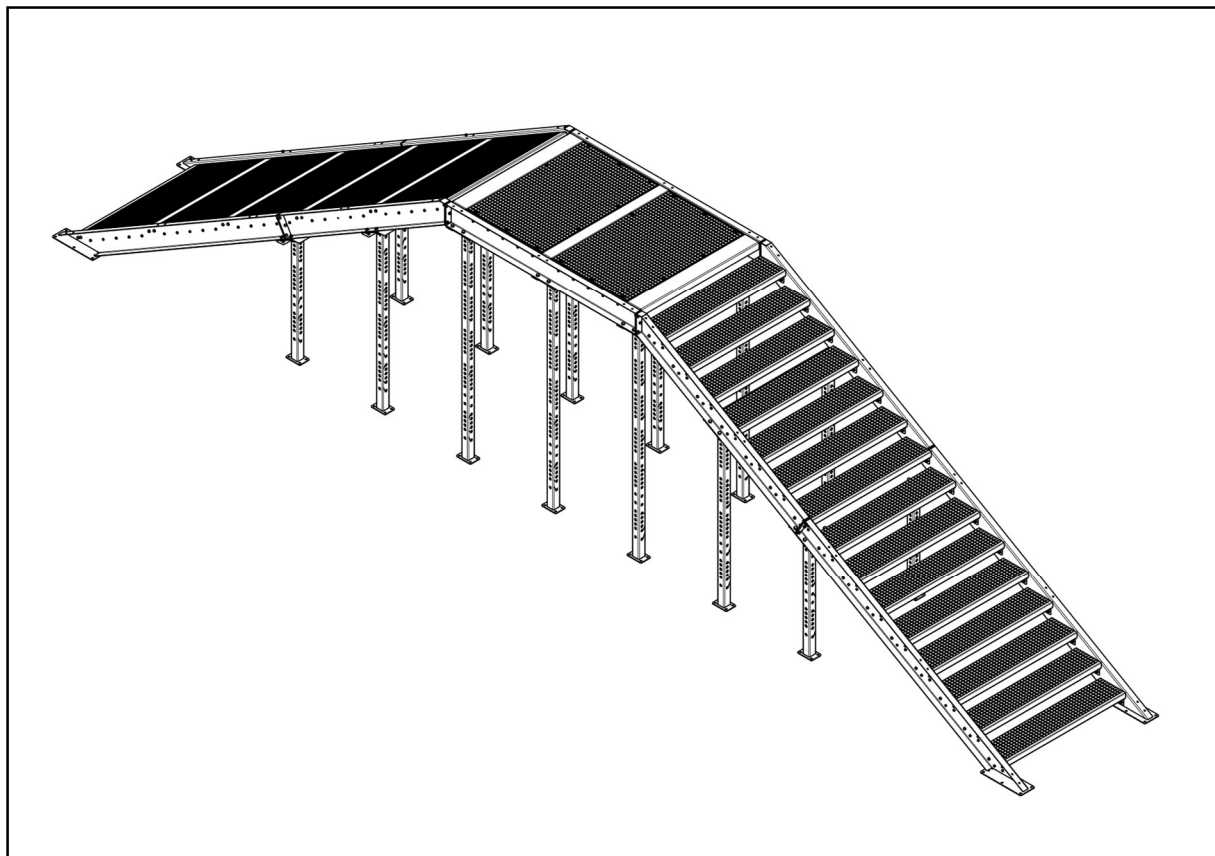
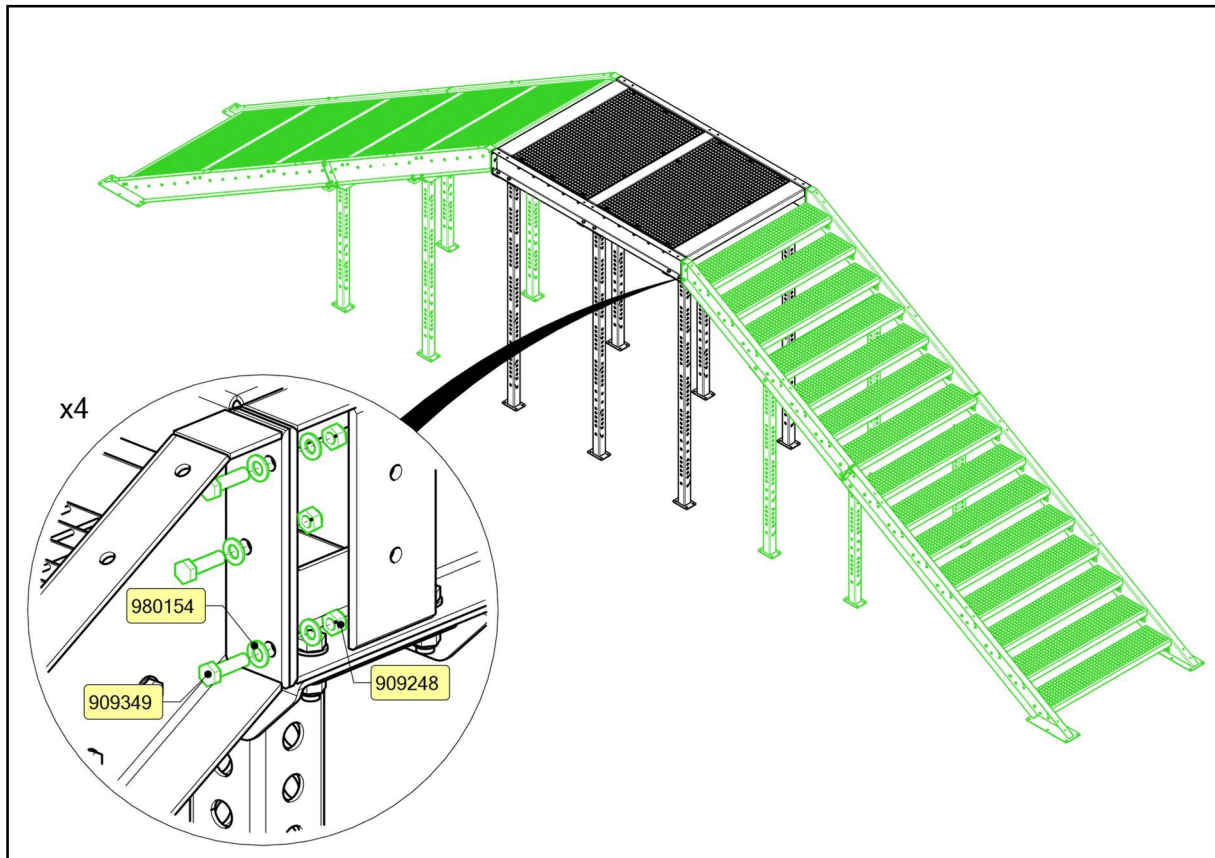

## SISU FITNESS STAIRS

### HANDRAIL (2 PCS)

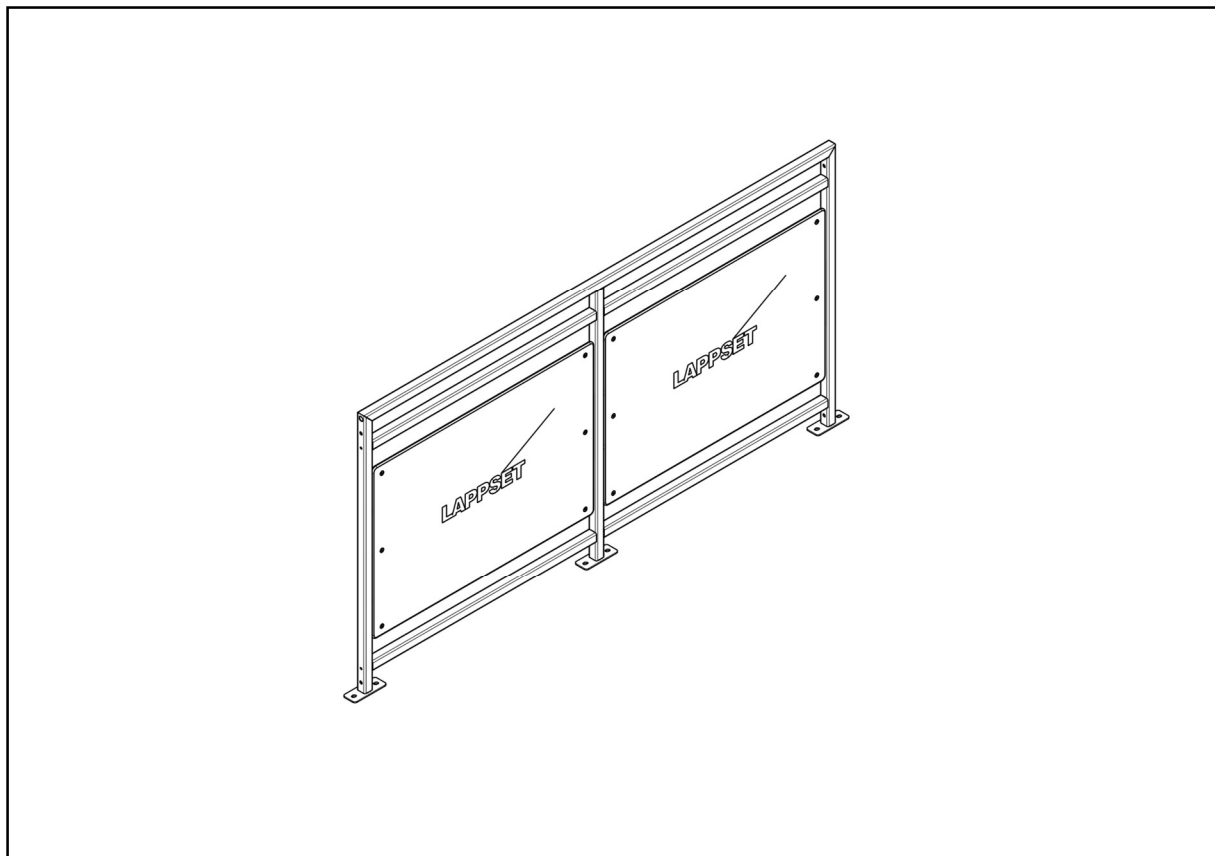
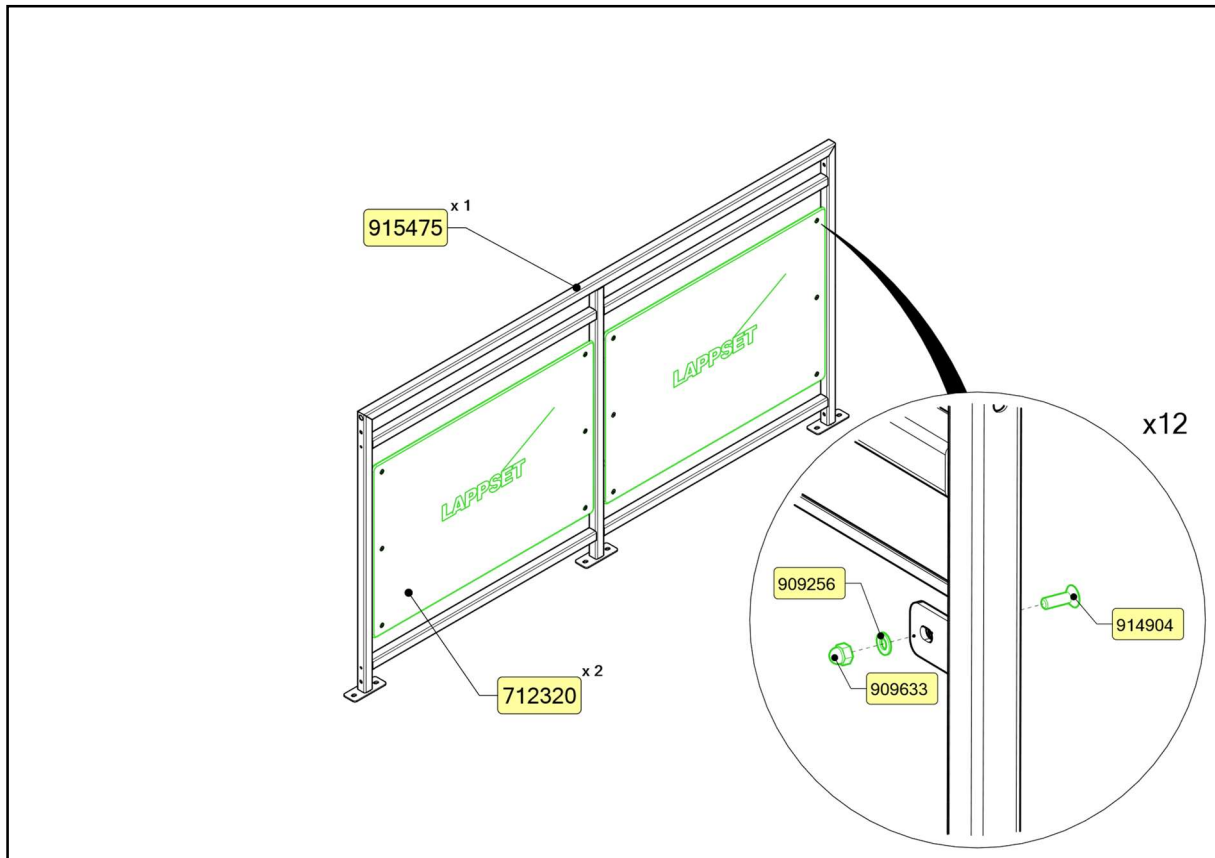

## SISU FITNESS STAIRS

### ASSEMBLY

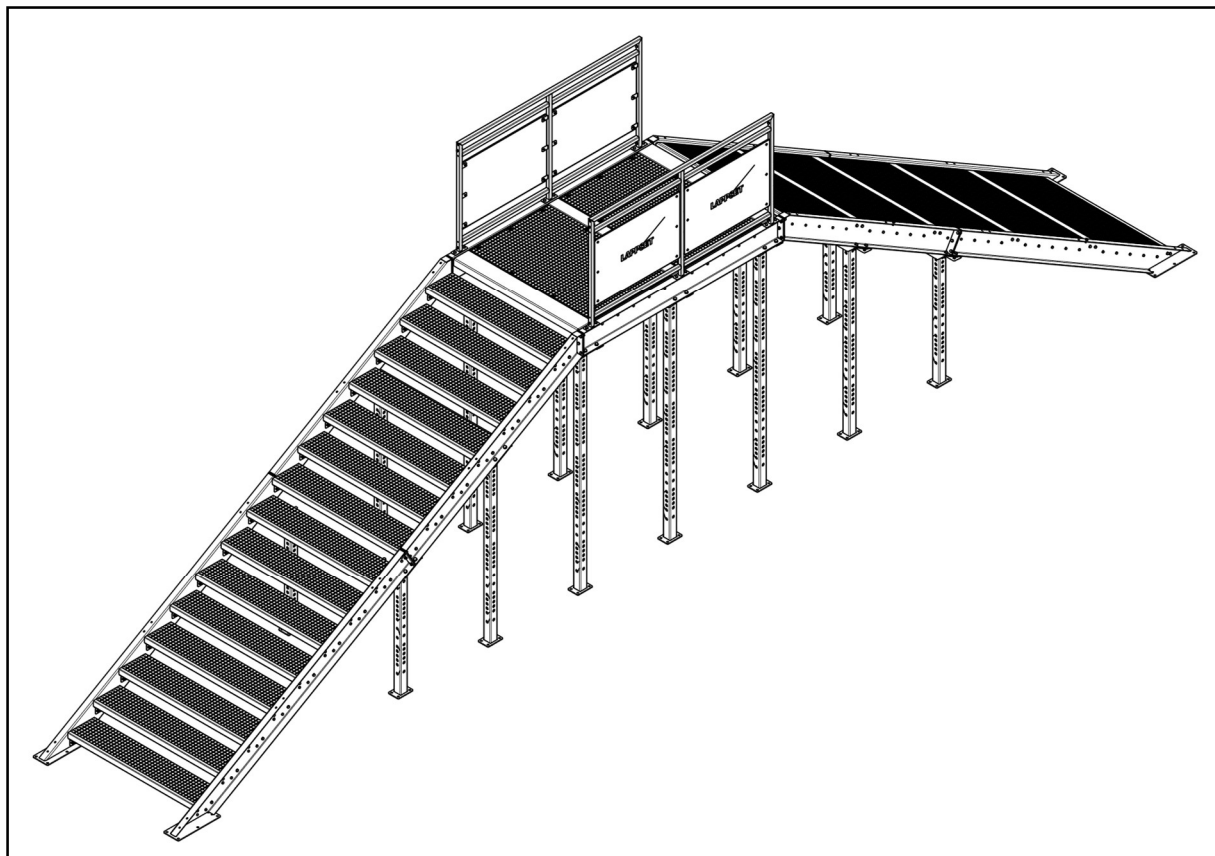
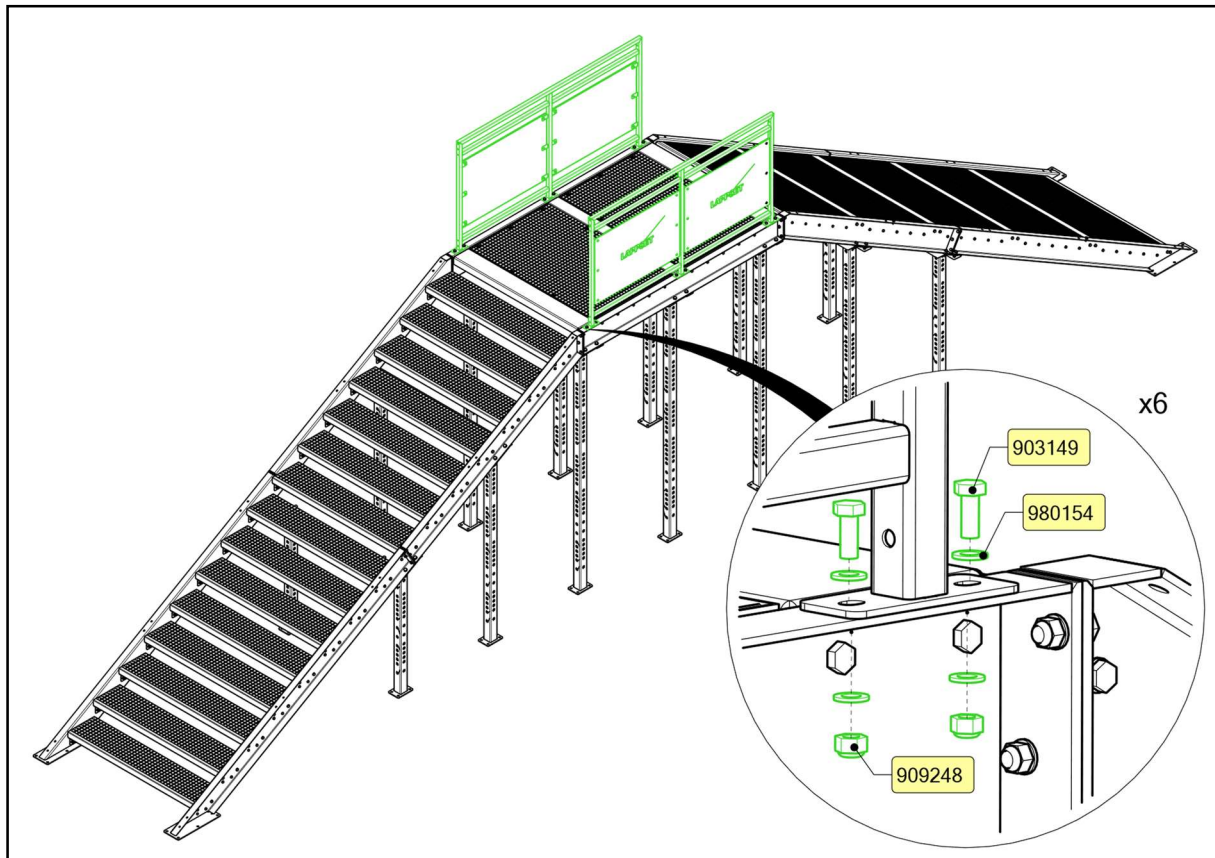

## SISU FITNESS STAIRS

### ASSEMBLY

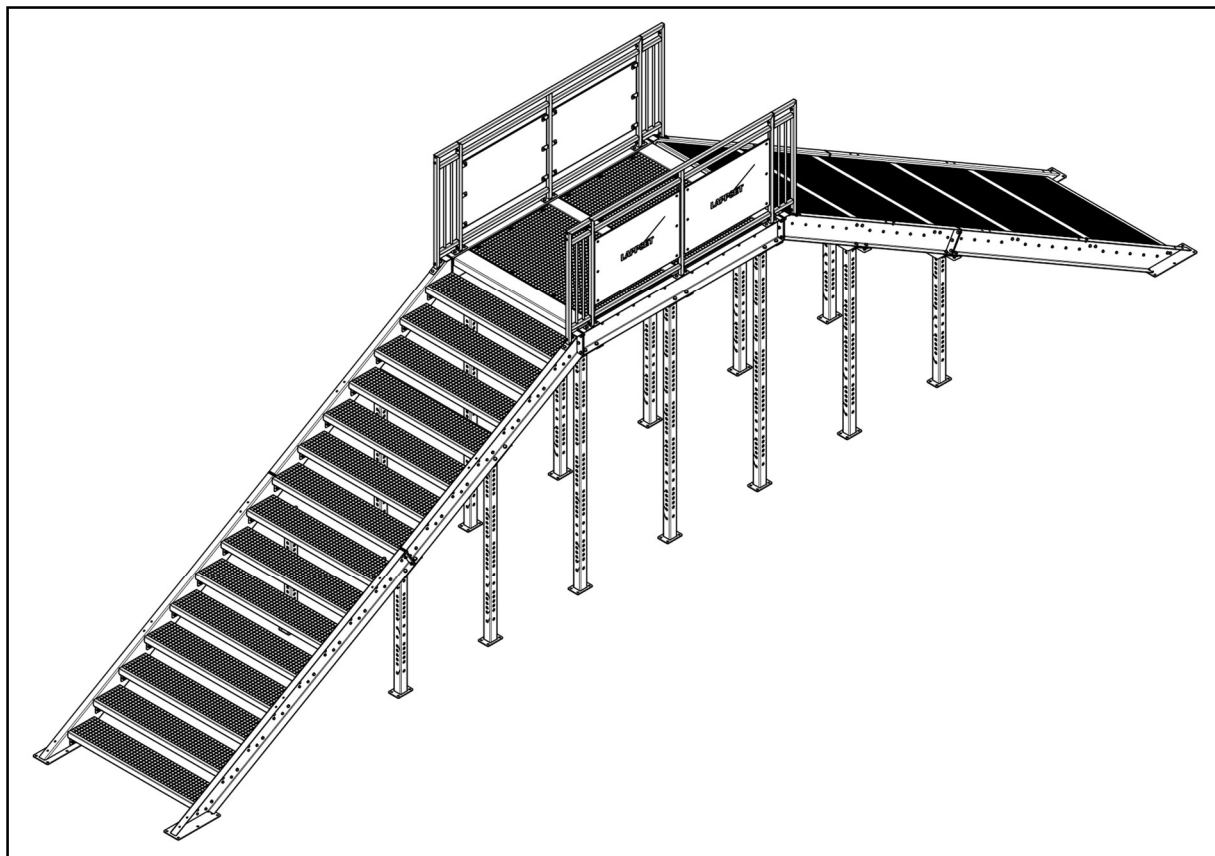
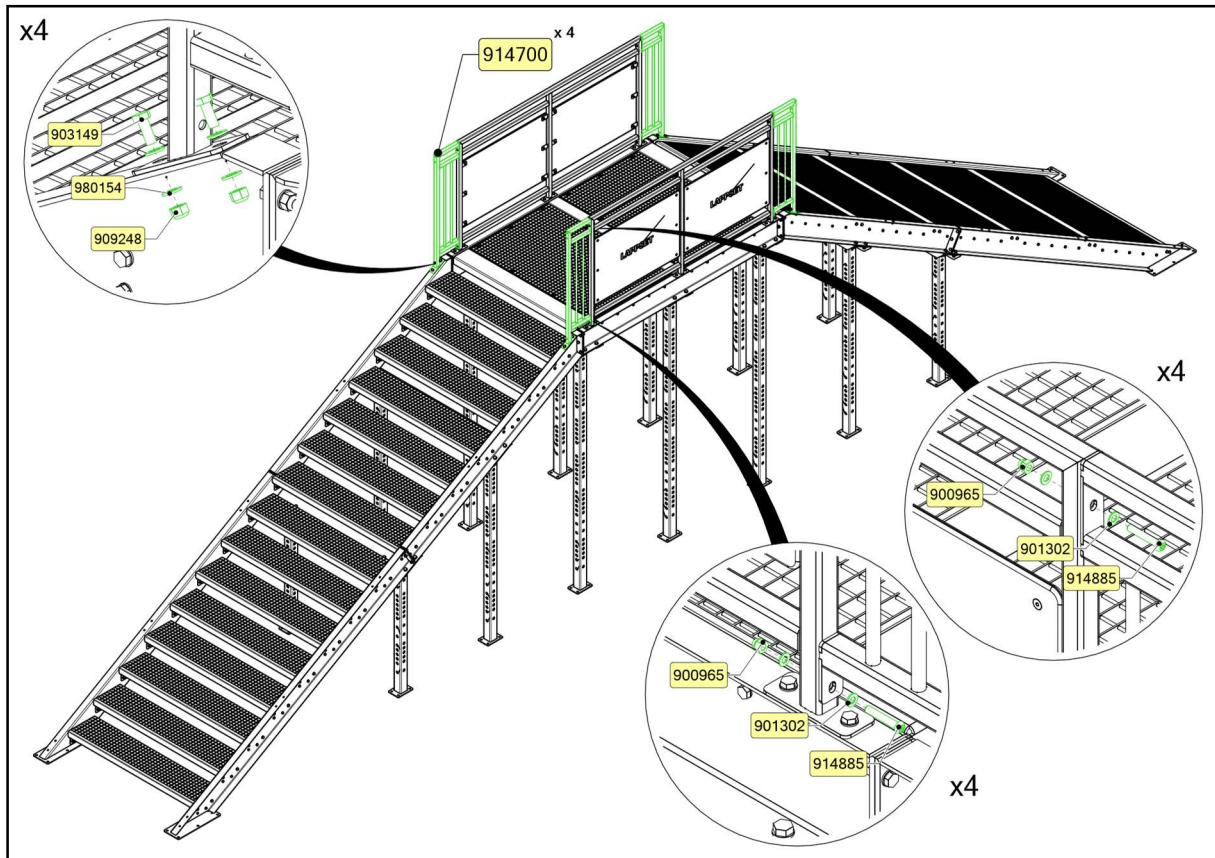

## SISU FITNESS STAIRS

### ASSEMBLY

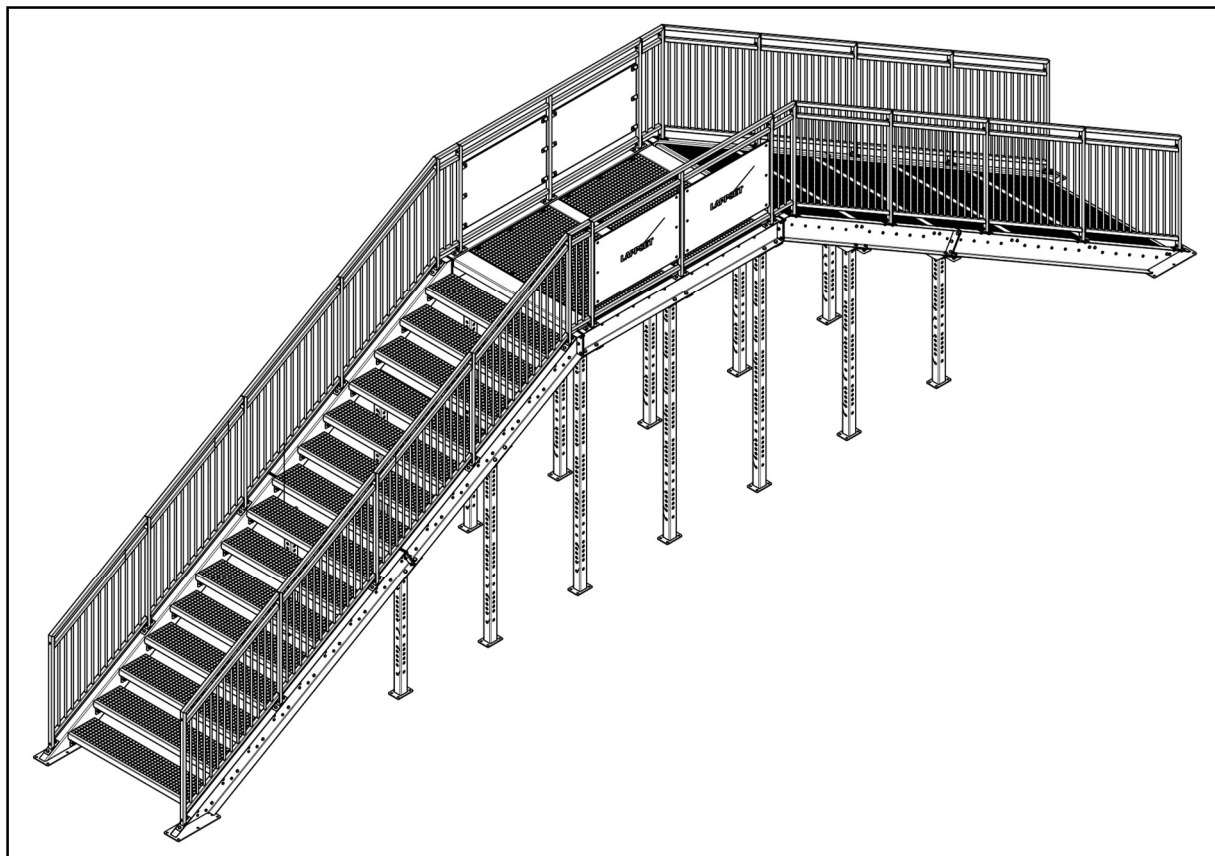
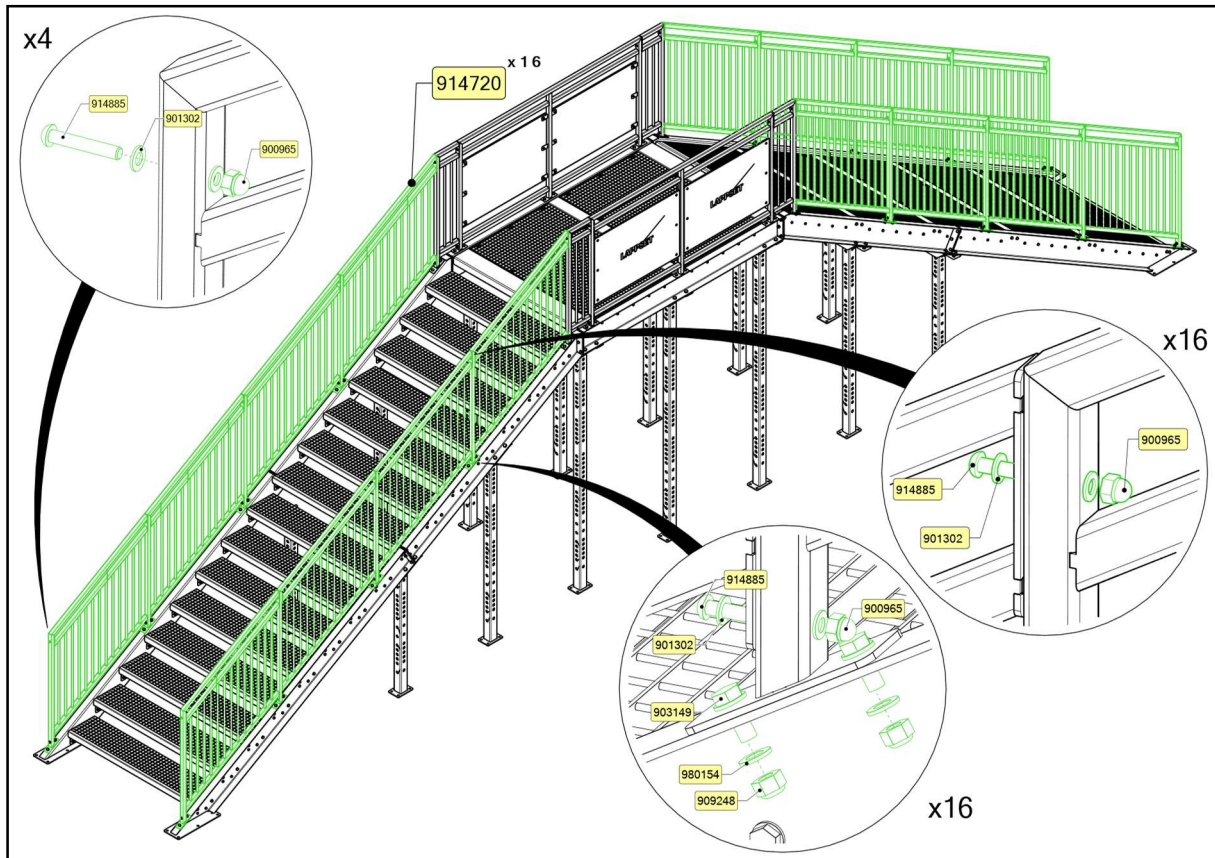

## SISU FITNESS STAIRS

### BALL TARGET (2 PCS)

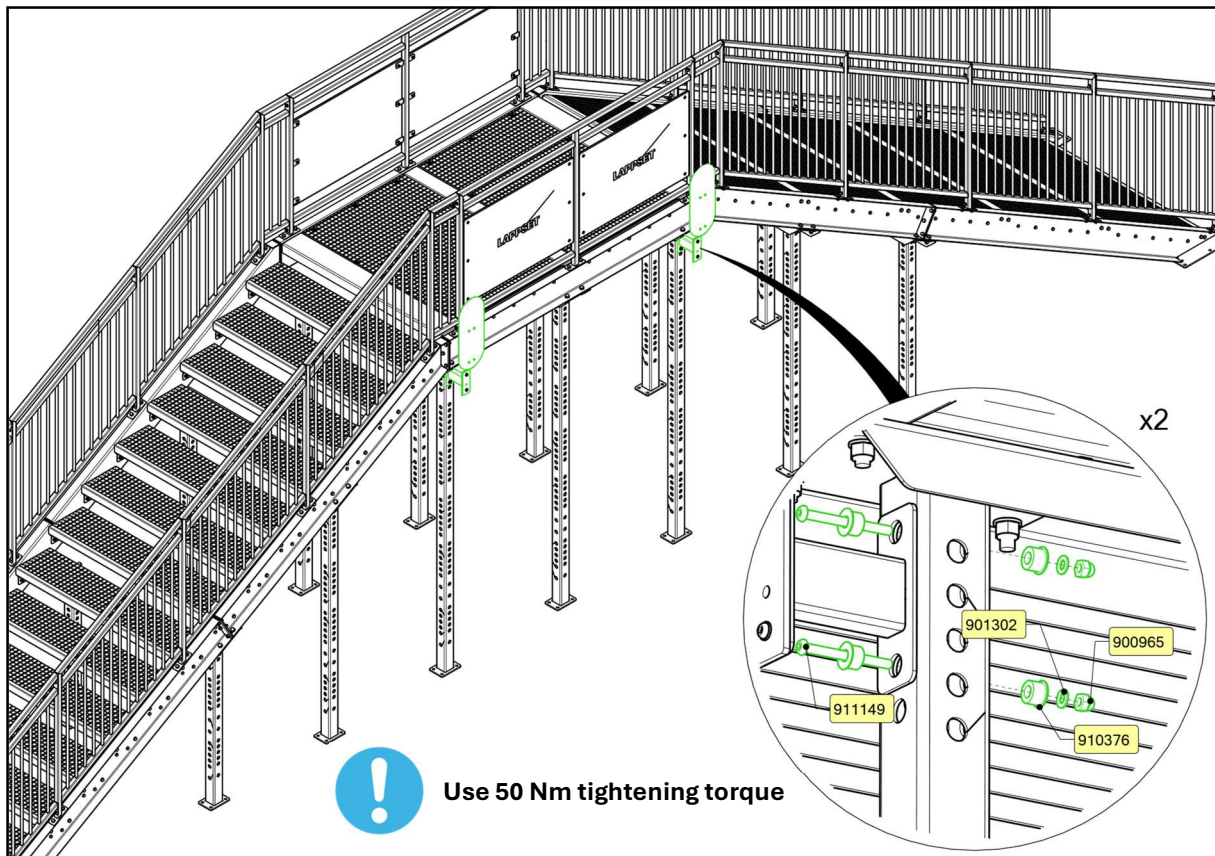
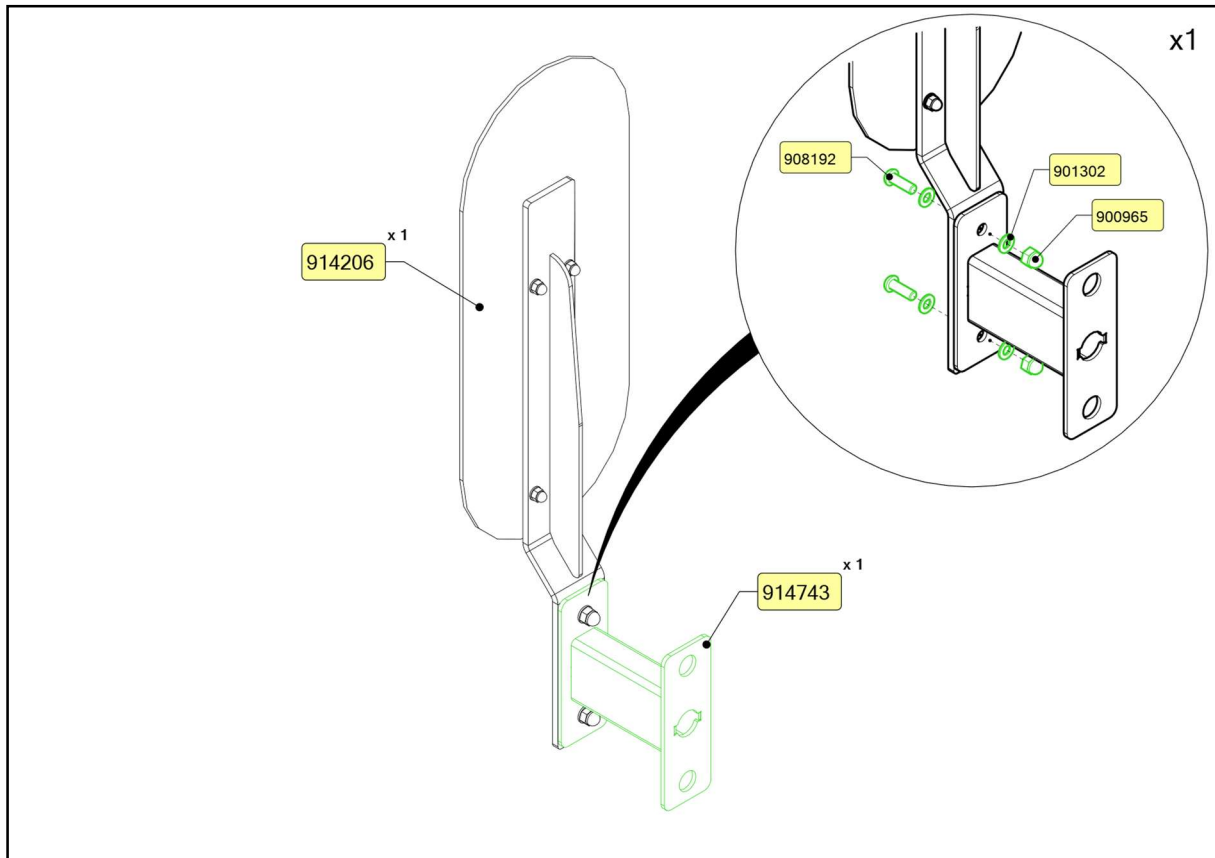

## SISU FITNESS STAIRS

### GYMNASTICS WALL

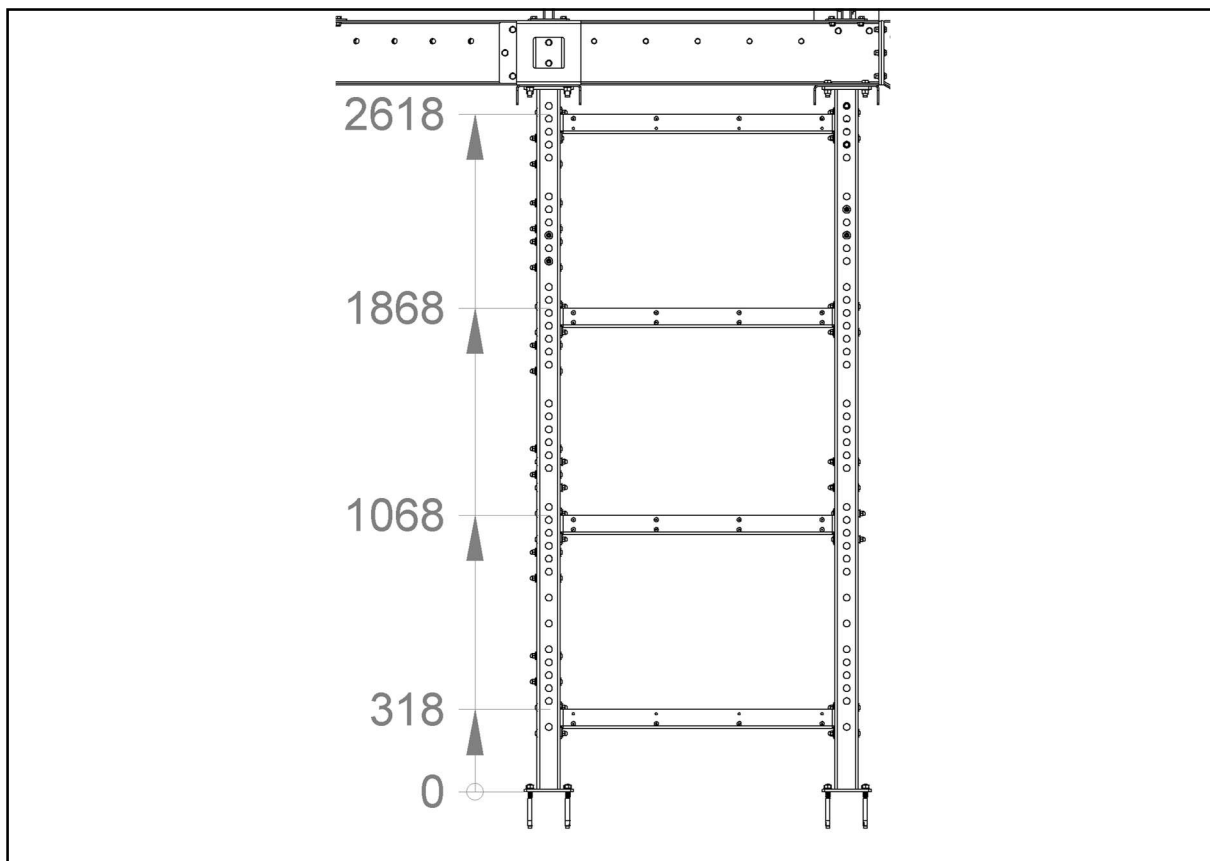
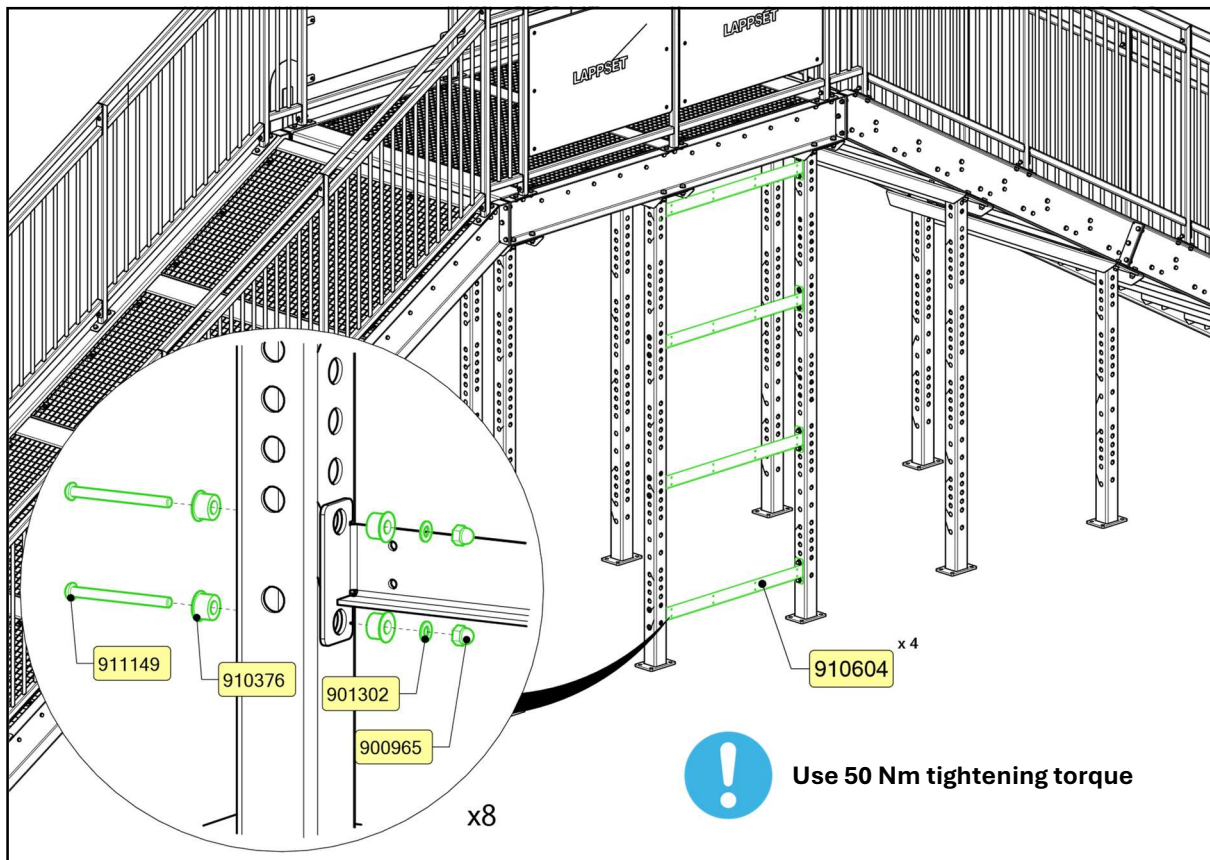

## SISU FITNESS STAIRS

### GYMNASTICS WALL

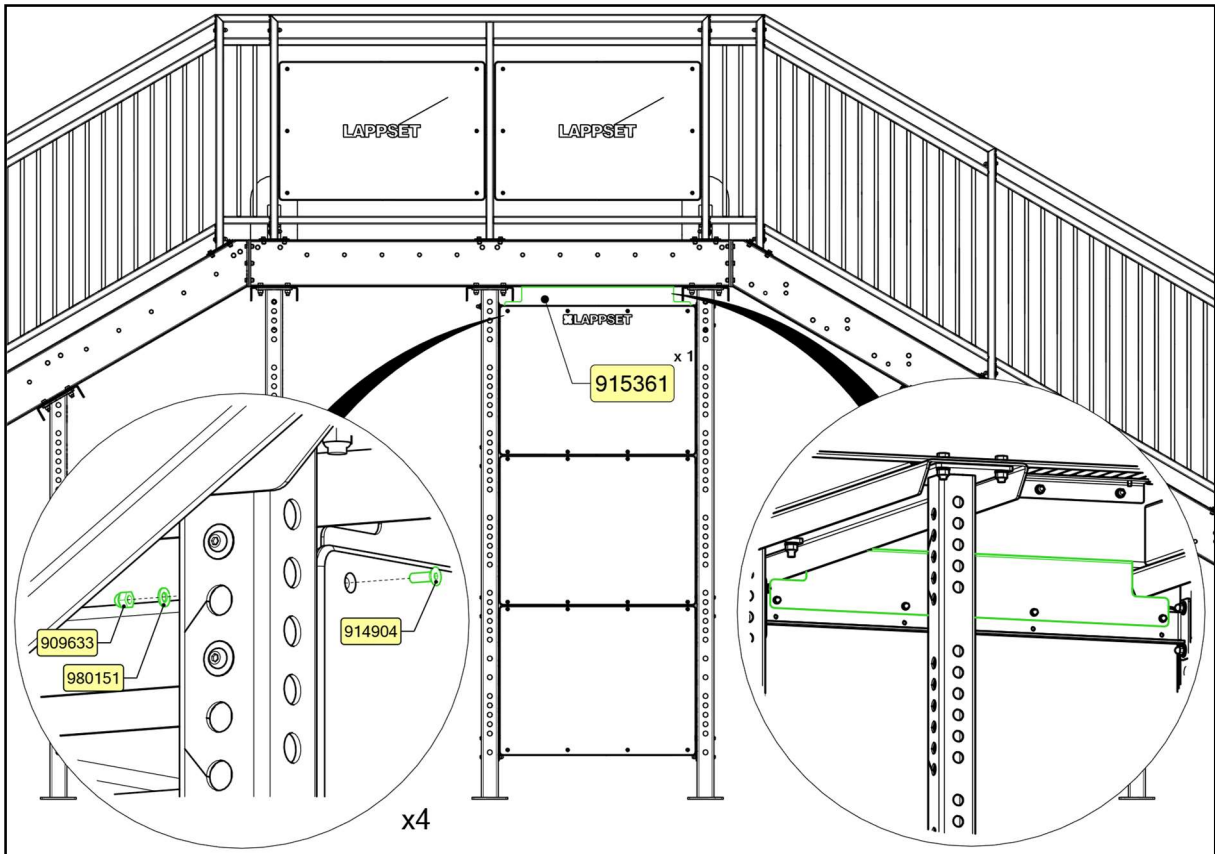
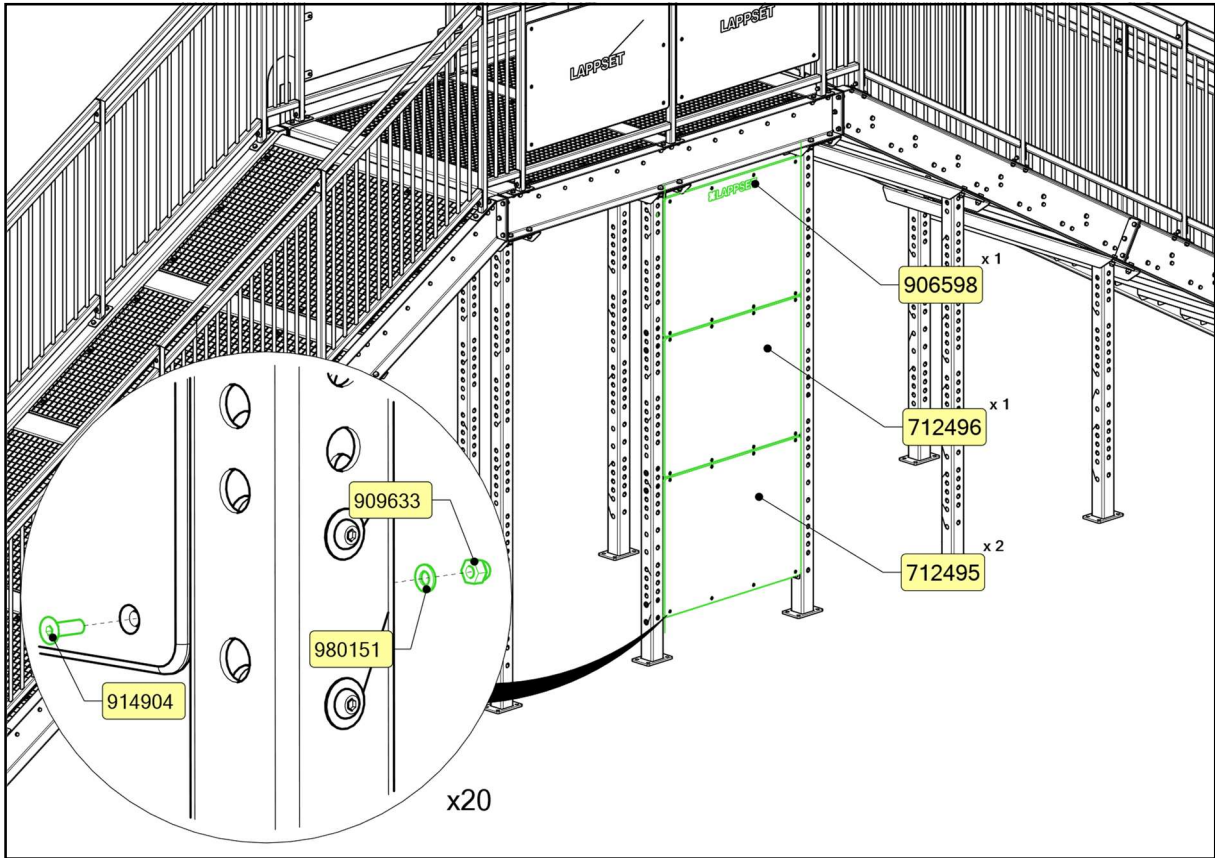

## SISU FITNESS STAIRS

### BARS-1 (4 PCS)

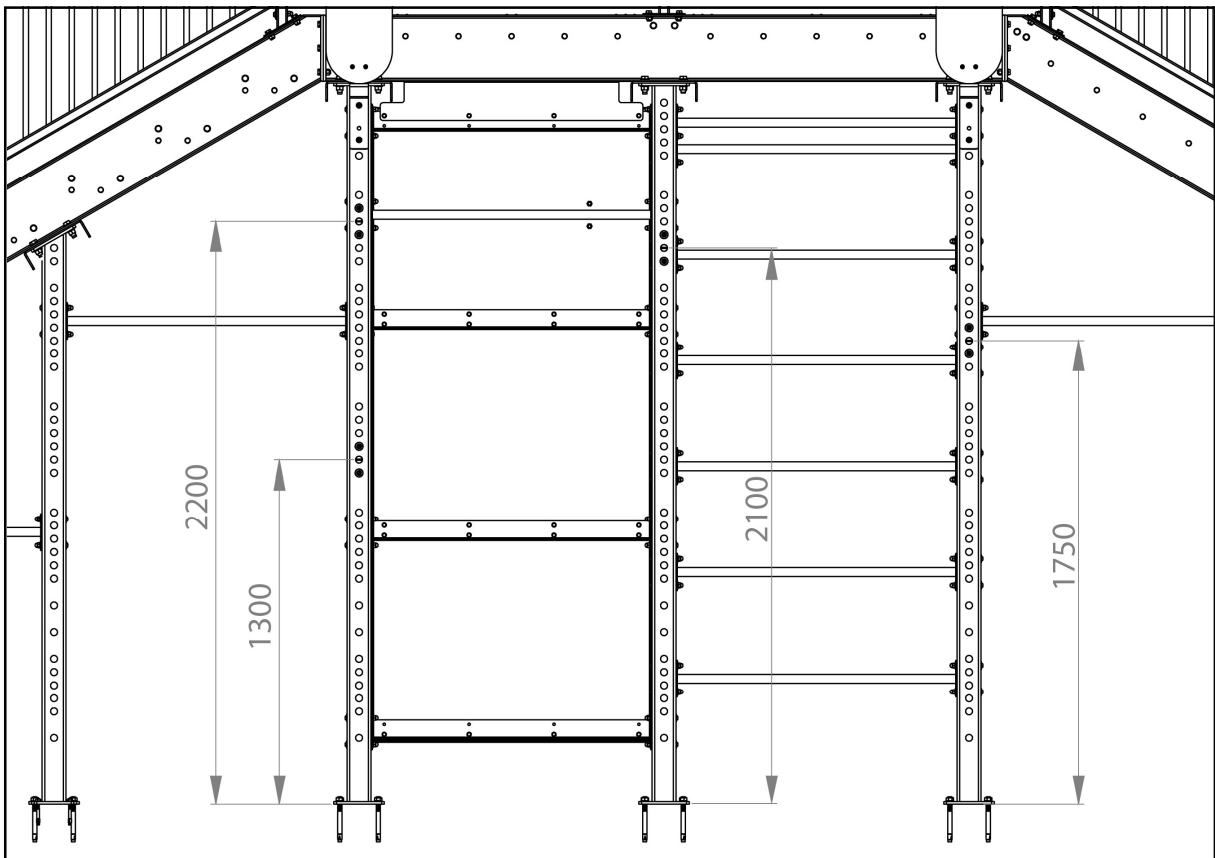
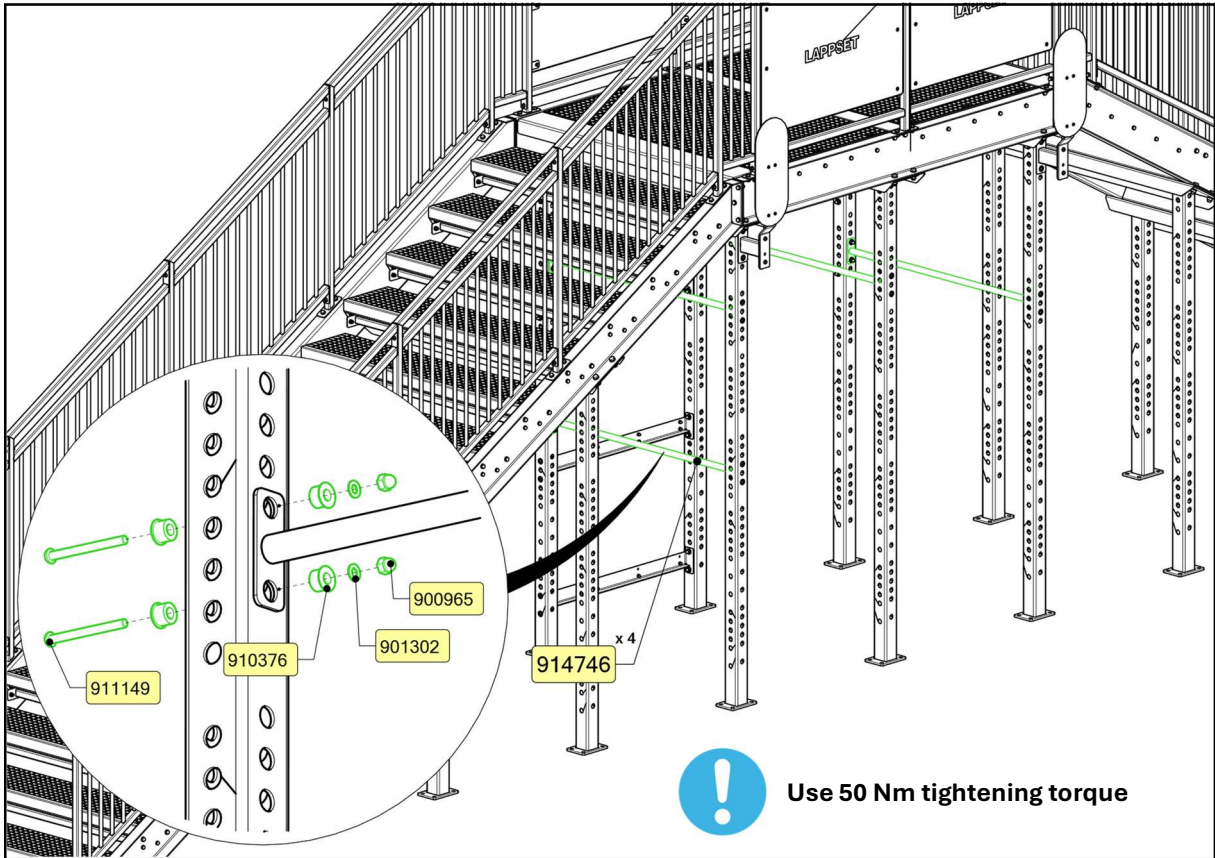

## SISU FITNESS STAIRS

### BARS-2 (9 PCS)

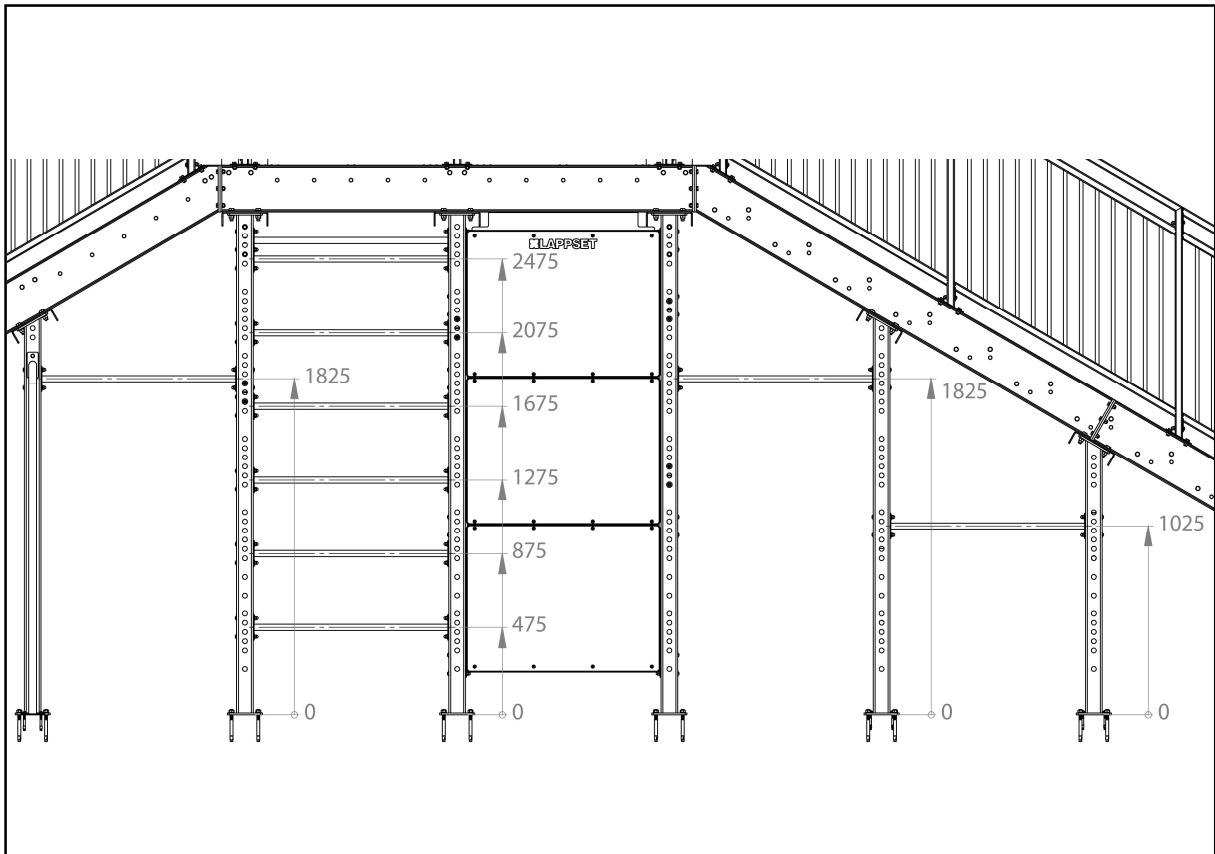
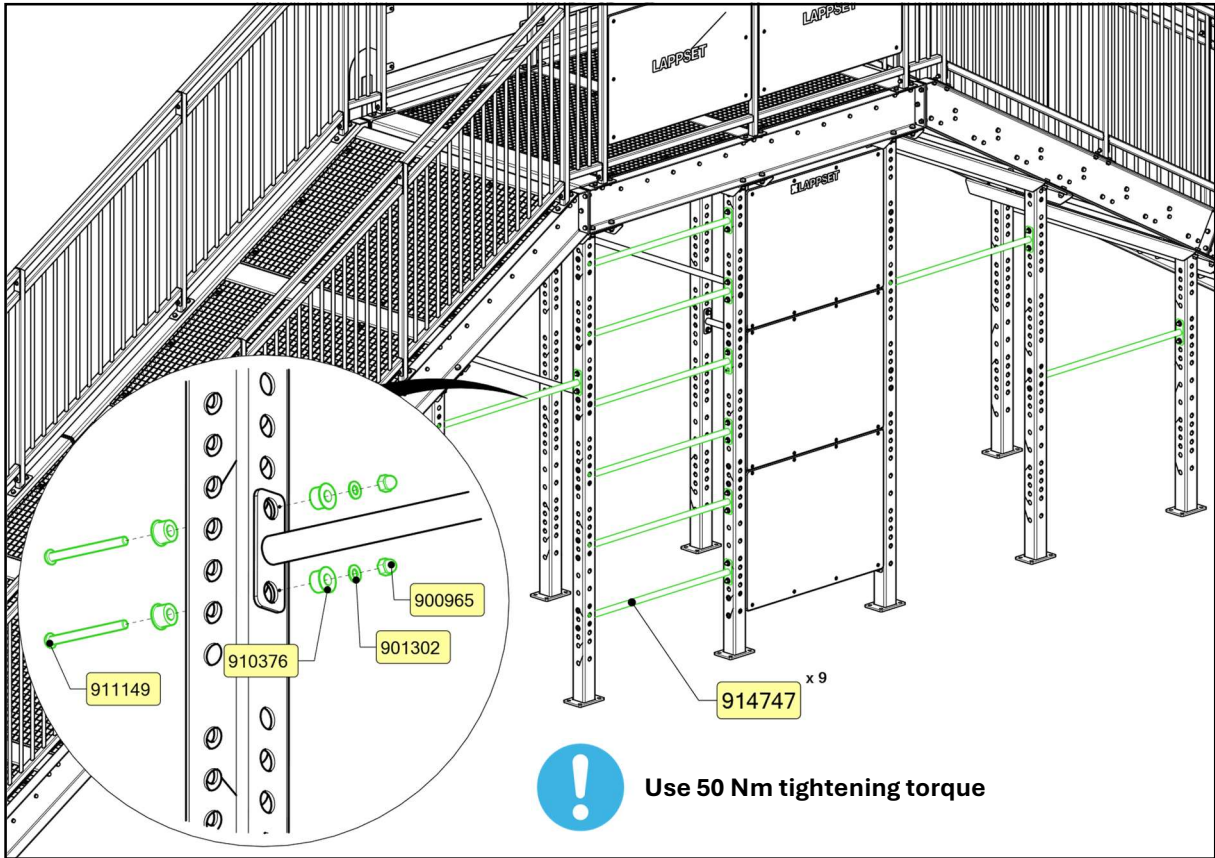

## SISU FITNESS STAIRS

### BARS-3 (3 PCS)

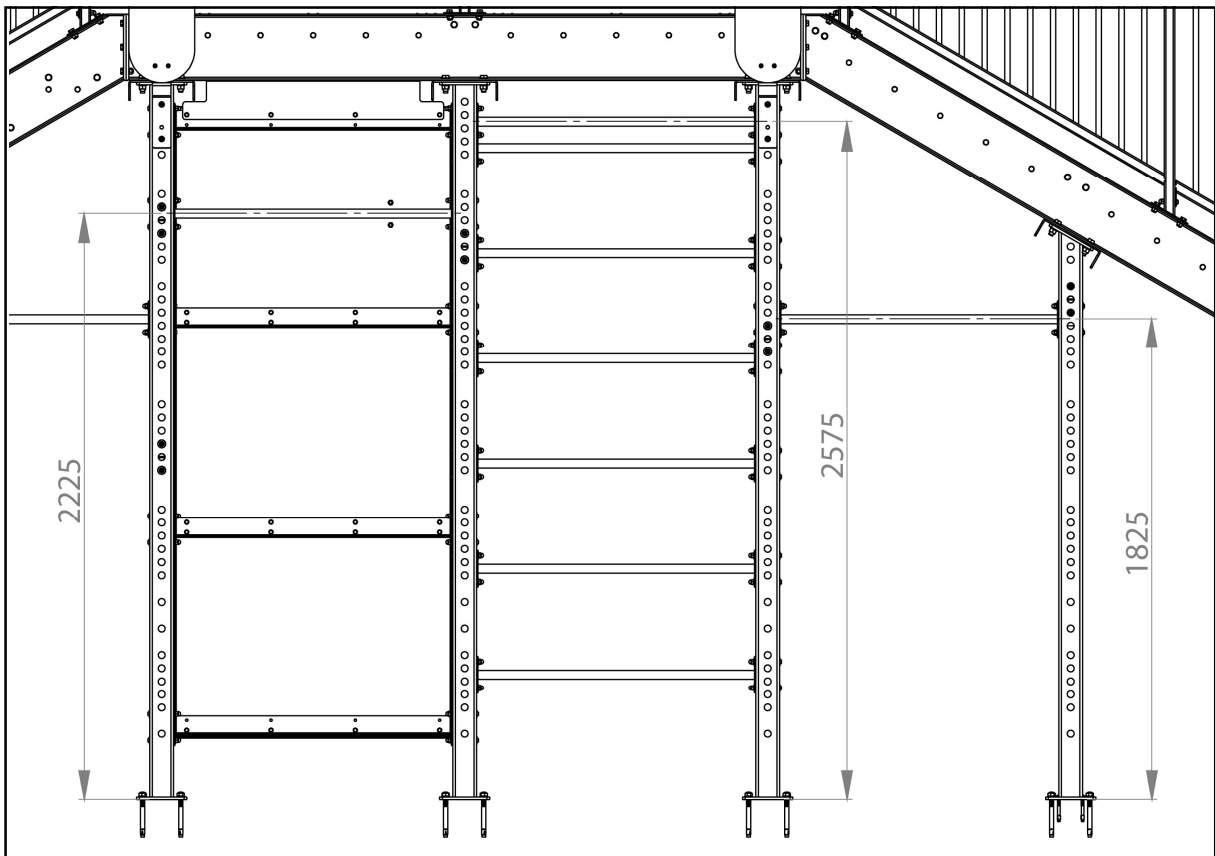
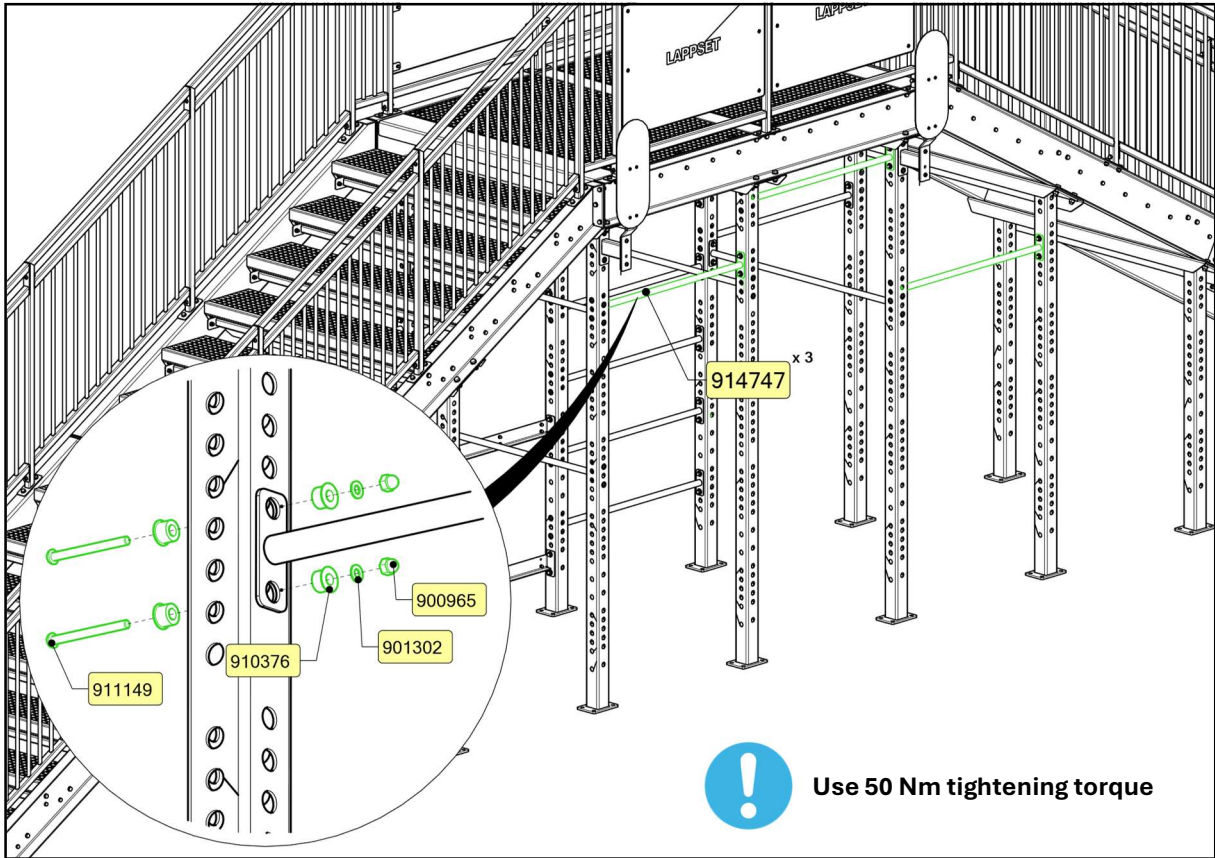

## SISU FITNESS STAIRS

### ROPE RINGS (6 PCS)

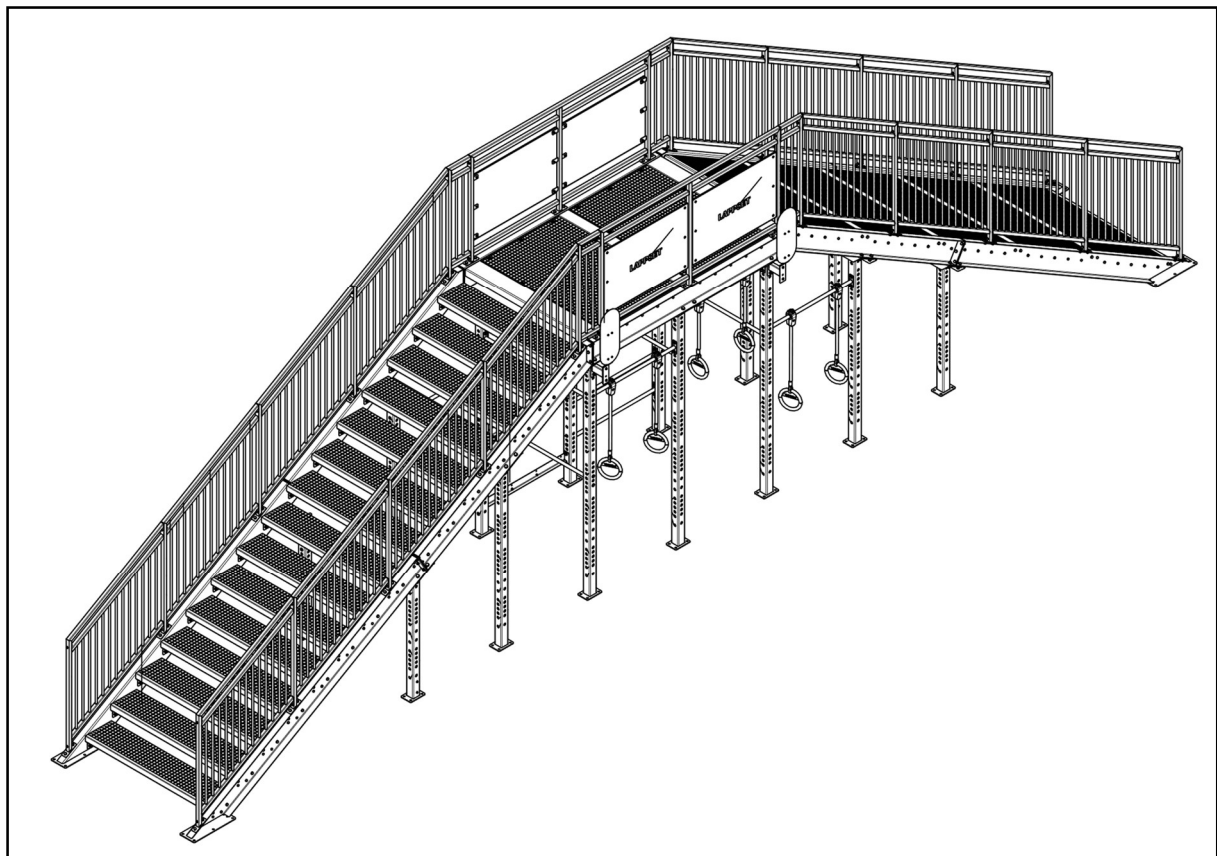
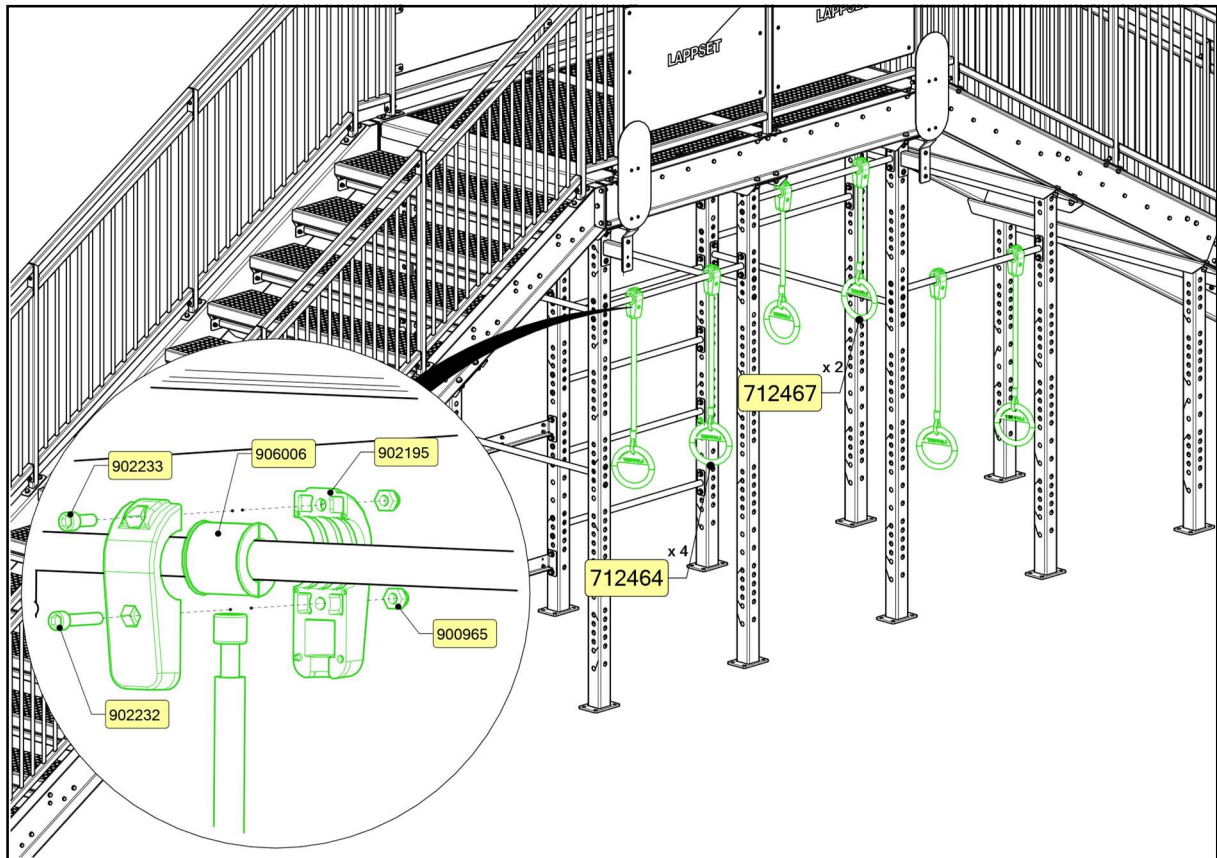

## SISU FITNESS STAIRS

### ANCHORS (80 PCS)

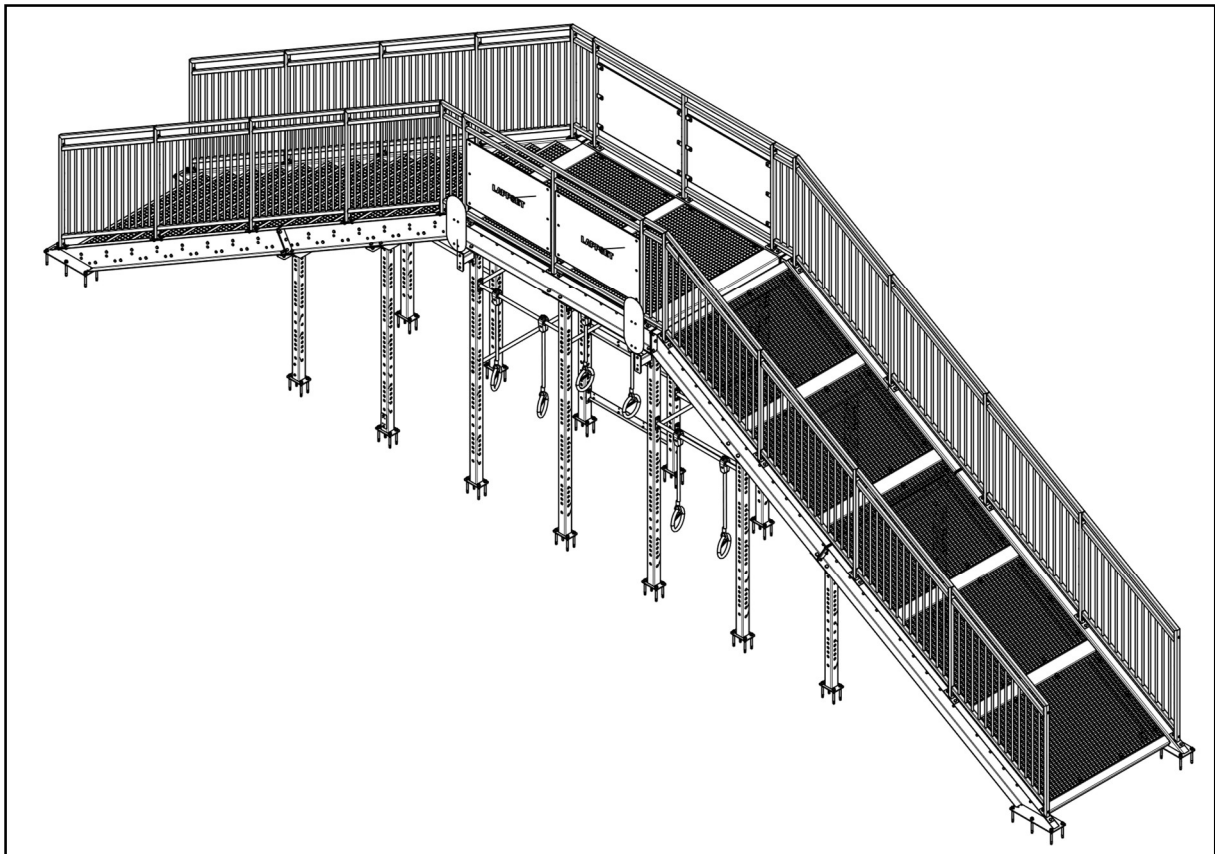
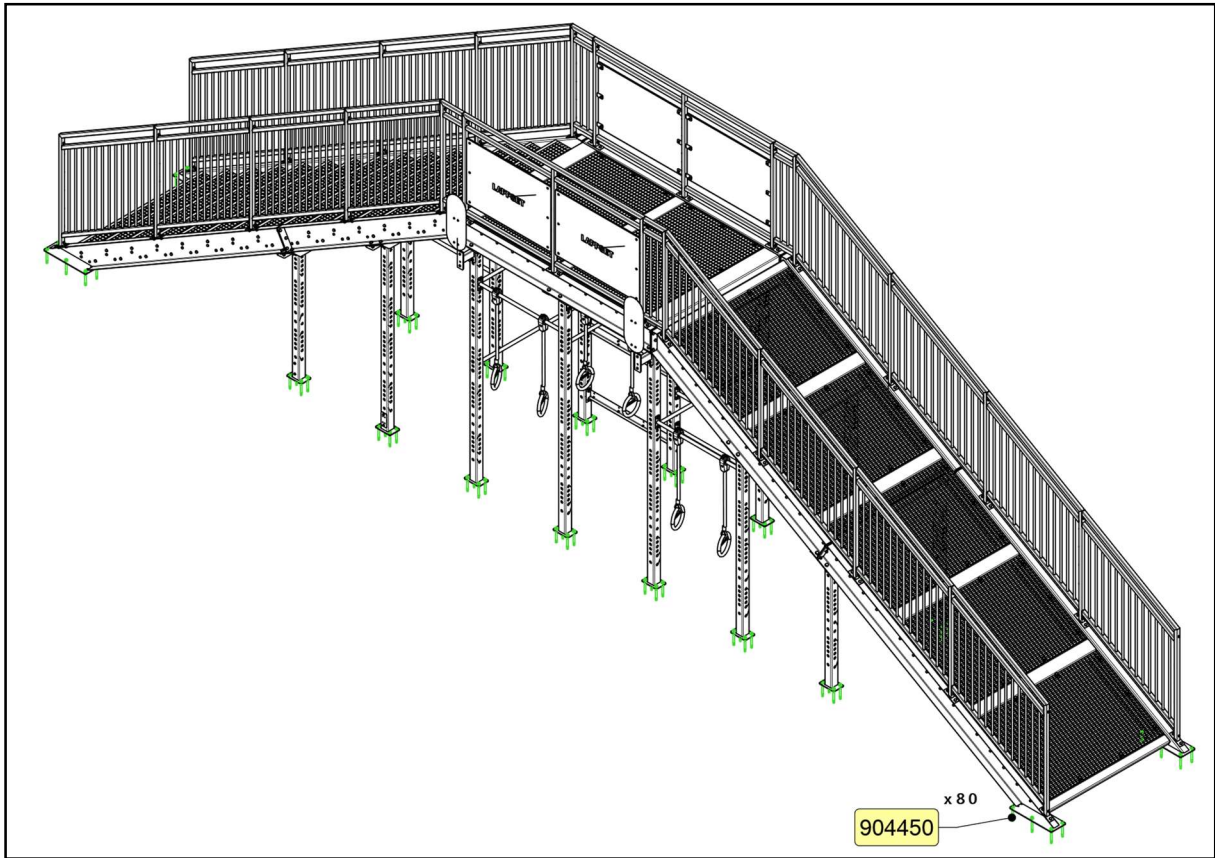

## SISU FITNESS STAIRS

### VERTICAL BAR (1 PC)

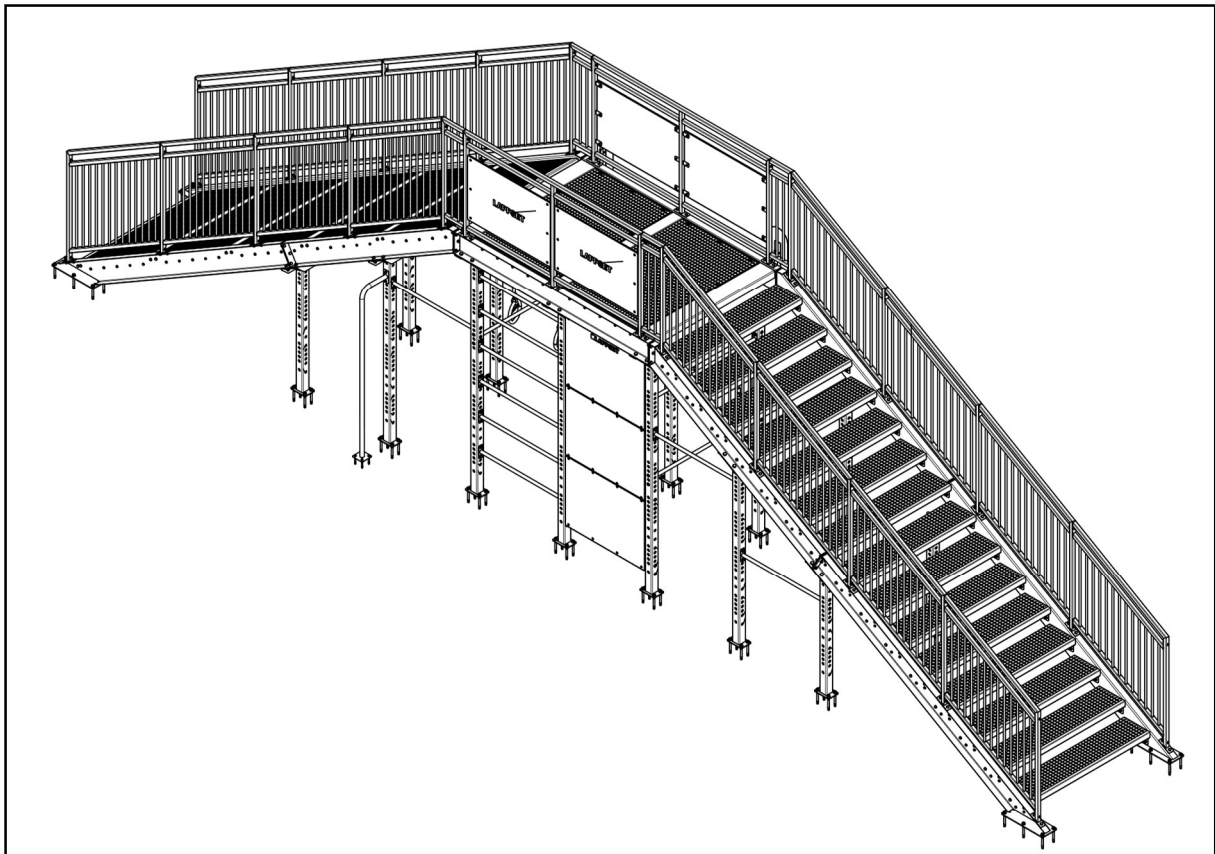
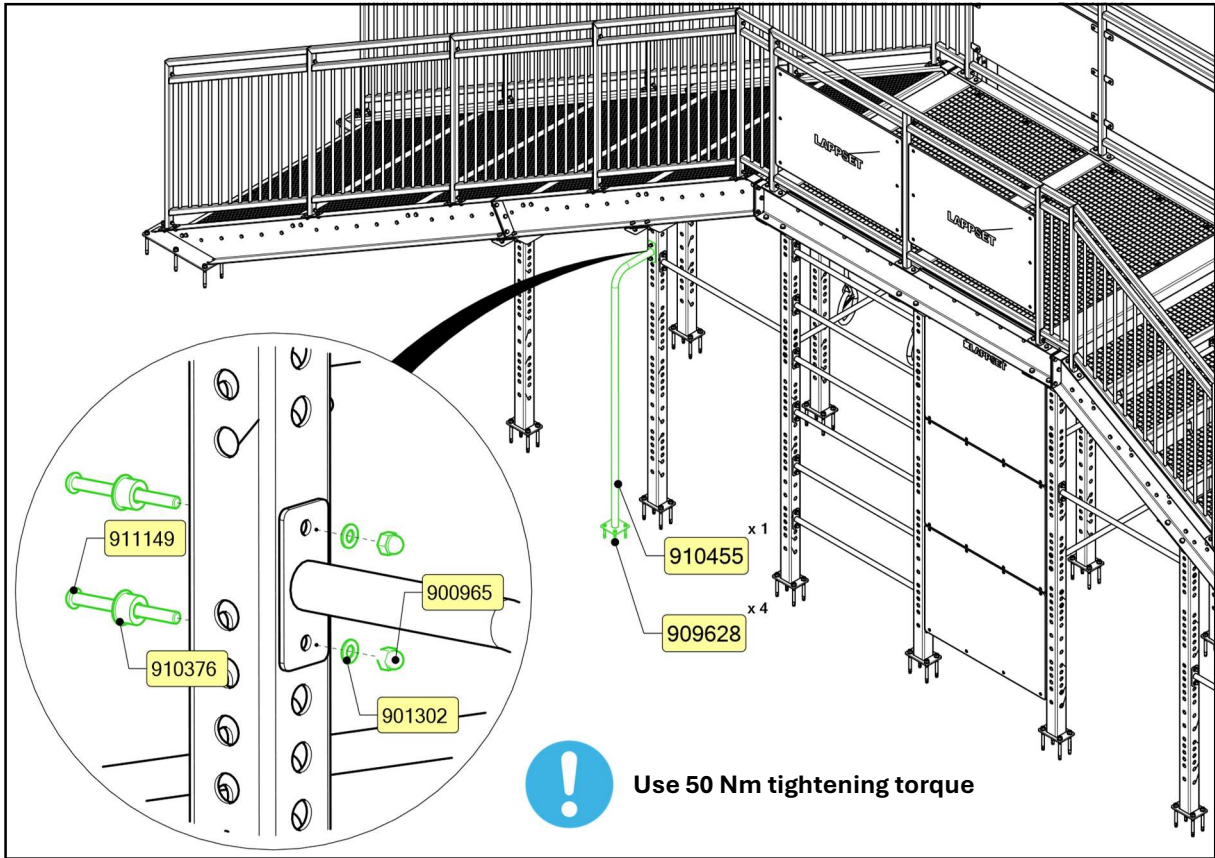

## SISU FITNESS STAIRS

### ABDOMINAL, BACK AND DIP MACHINE

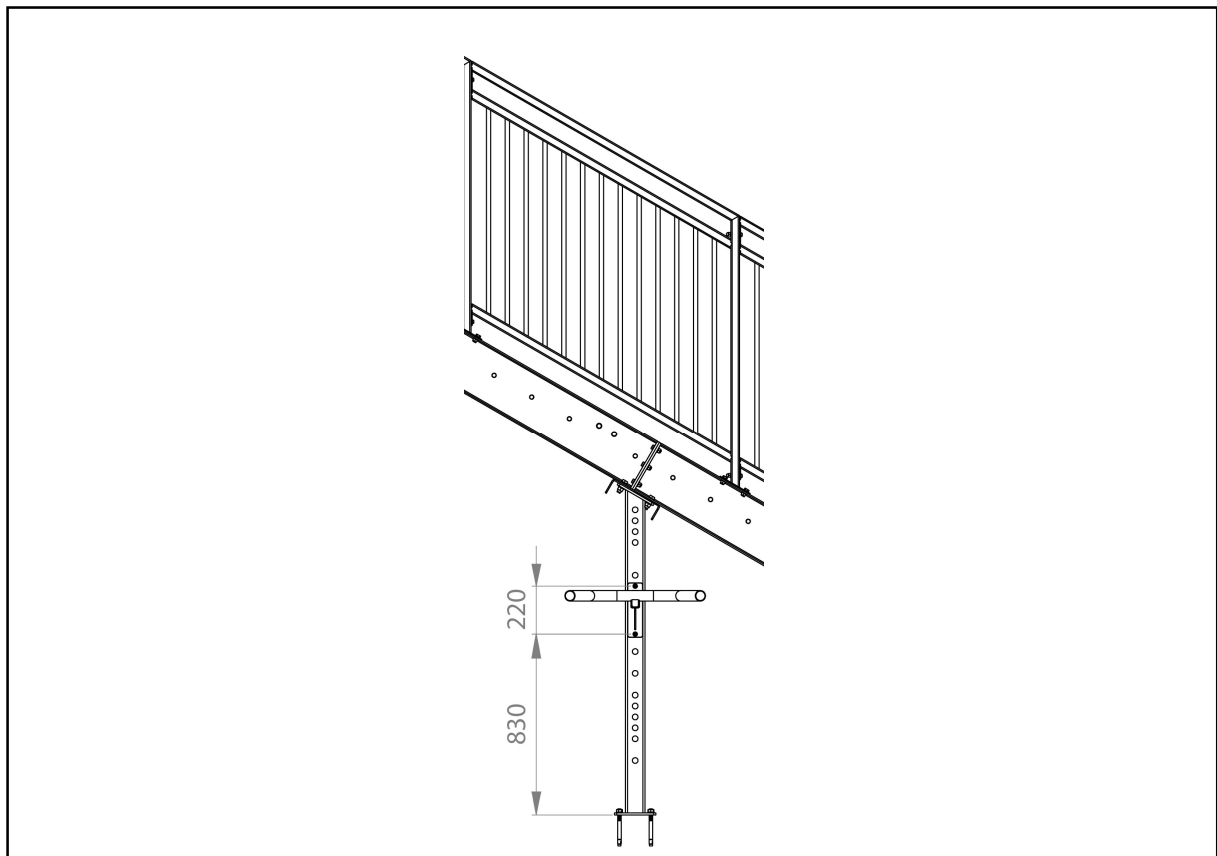
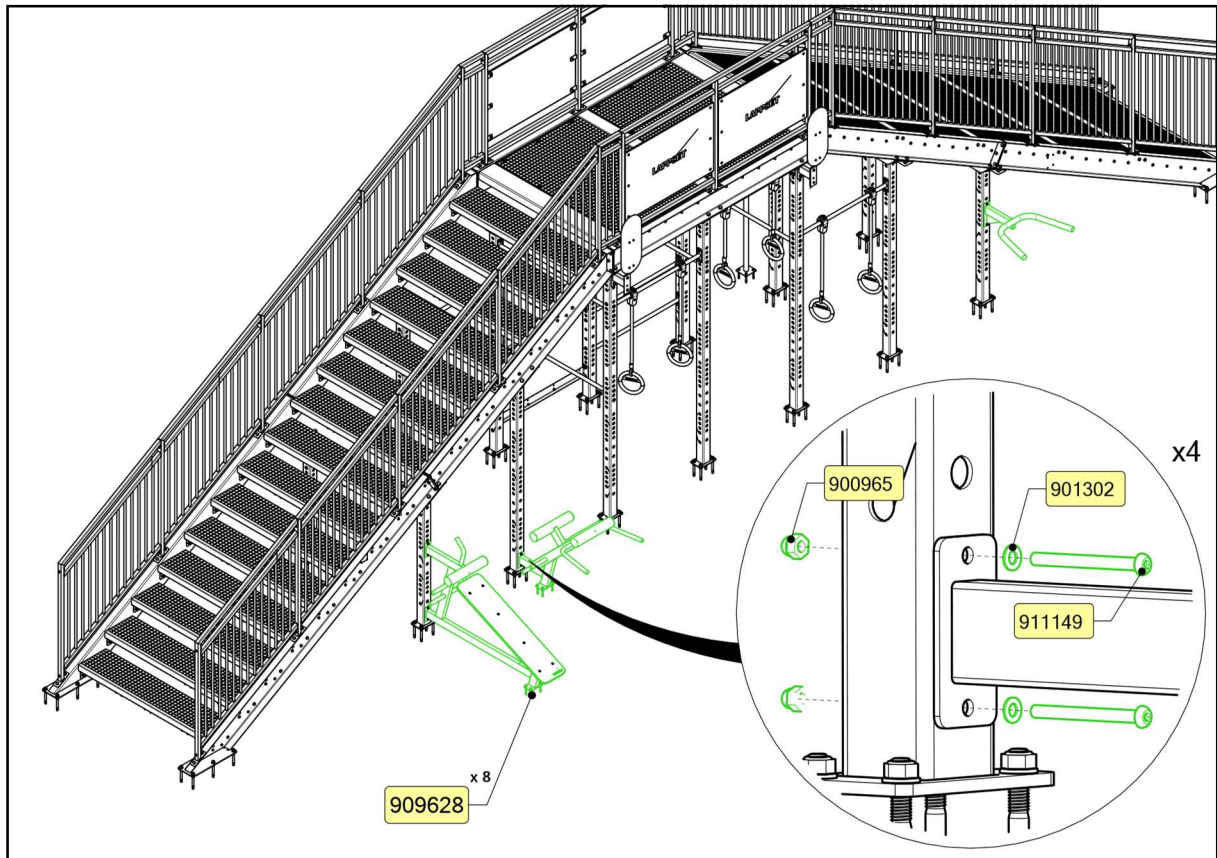

## SISU FITNESS STAIRS

### ABDOMINAL, BACK AND DIP MACHINE

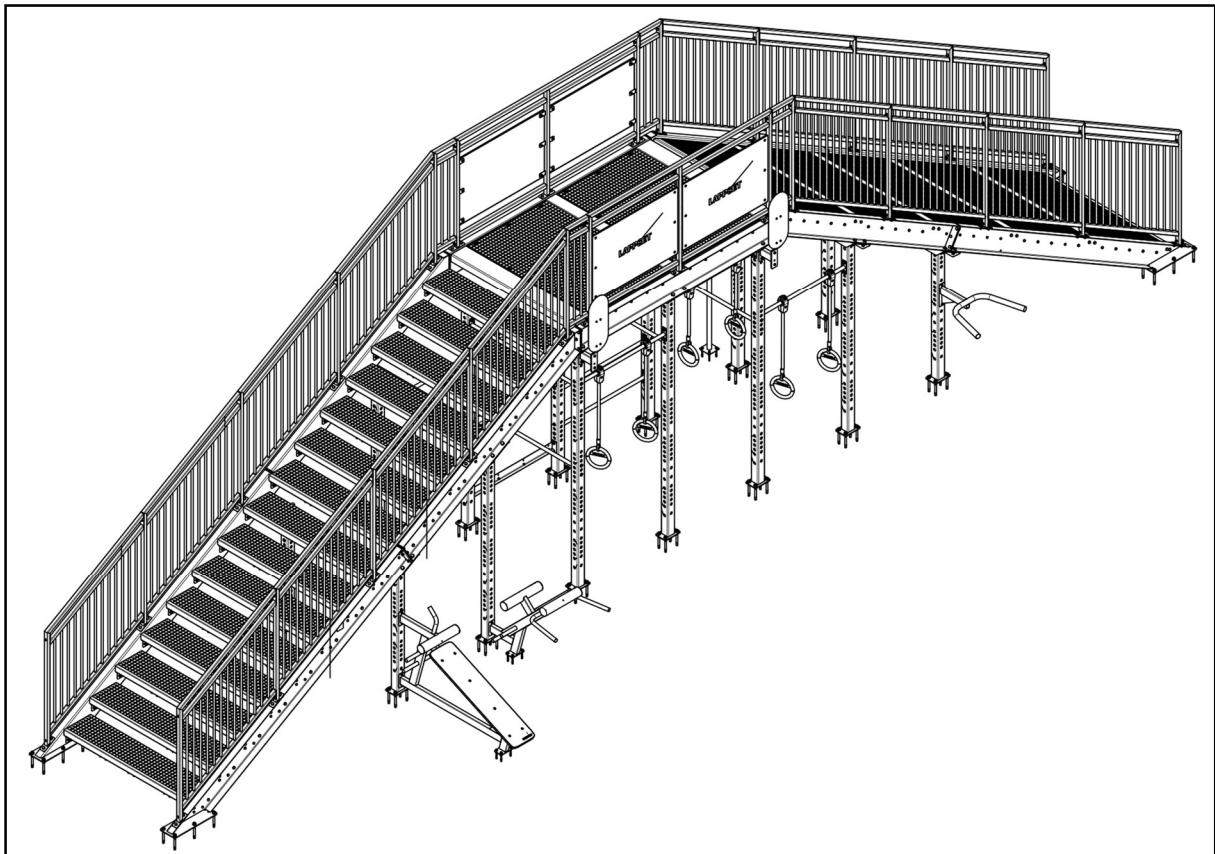
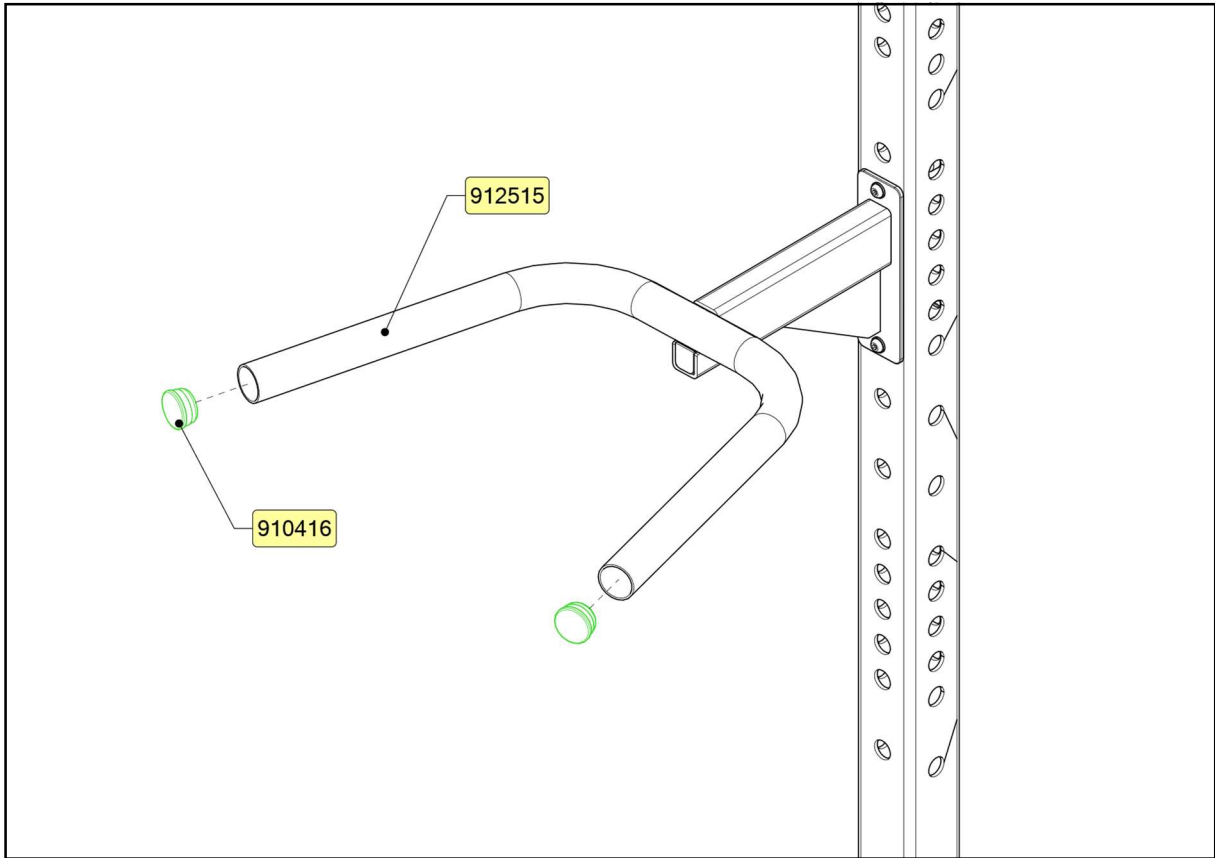

## SISU FITNESS STAIRS

### STAIR MARKS

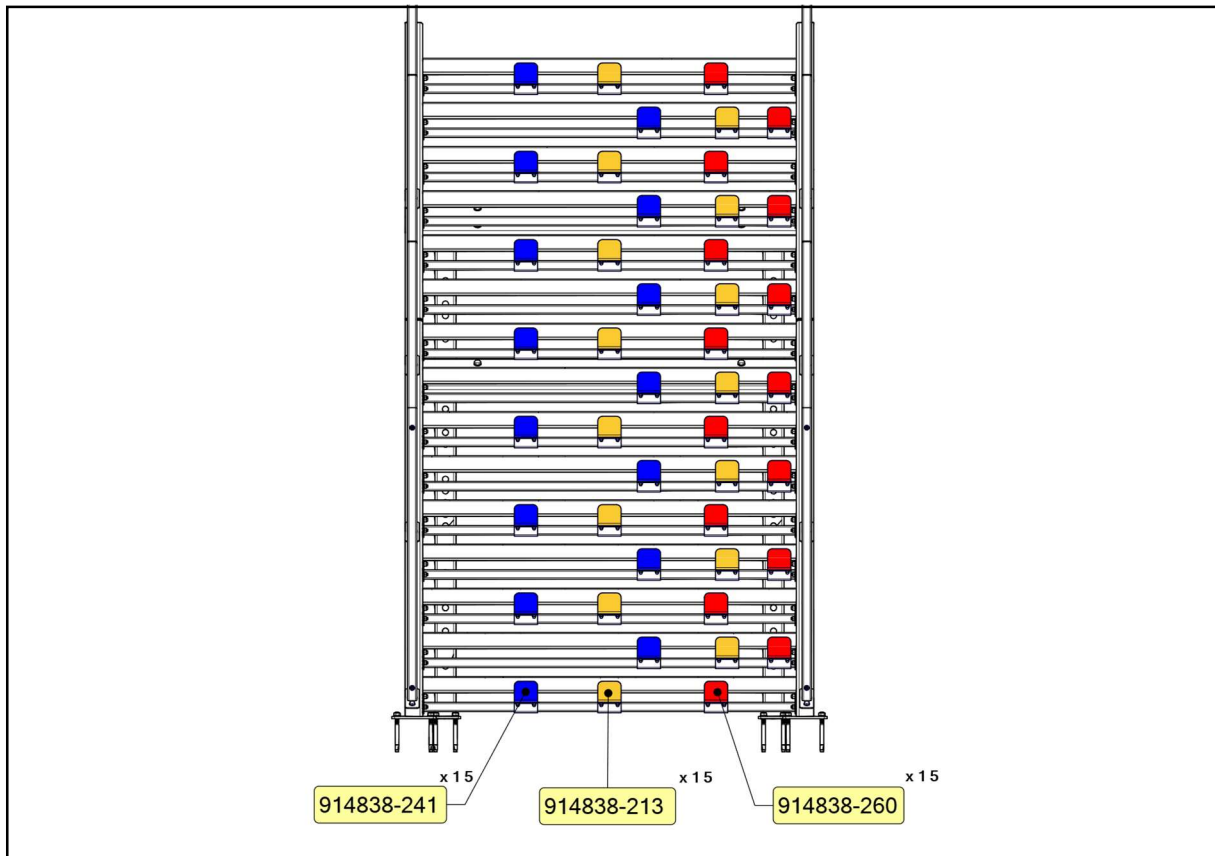
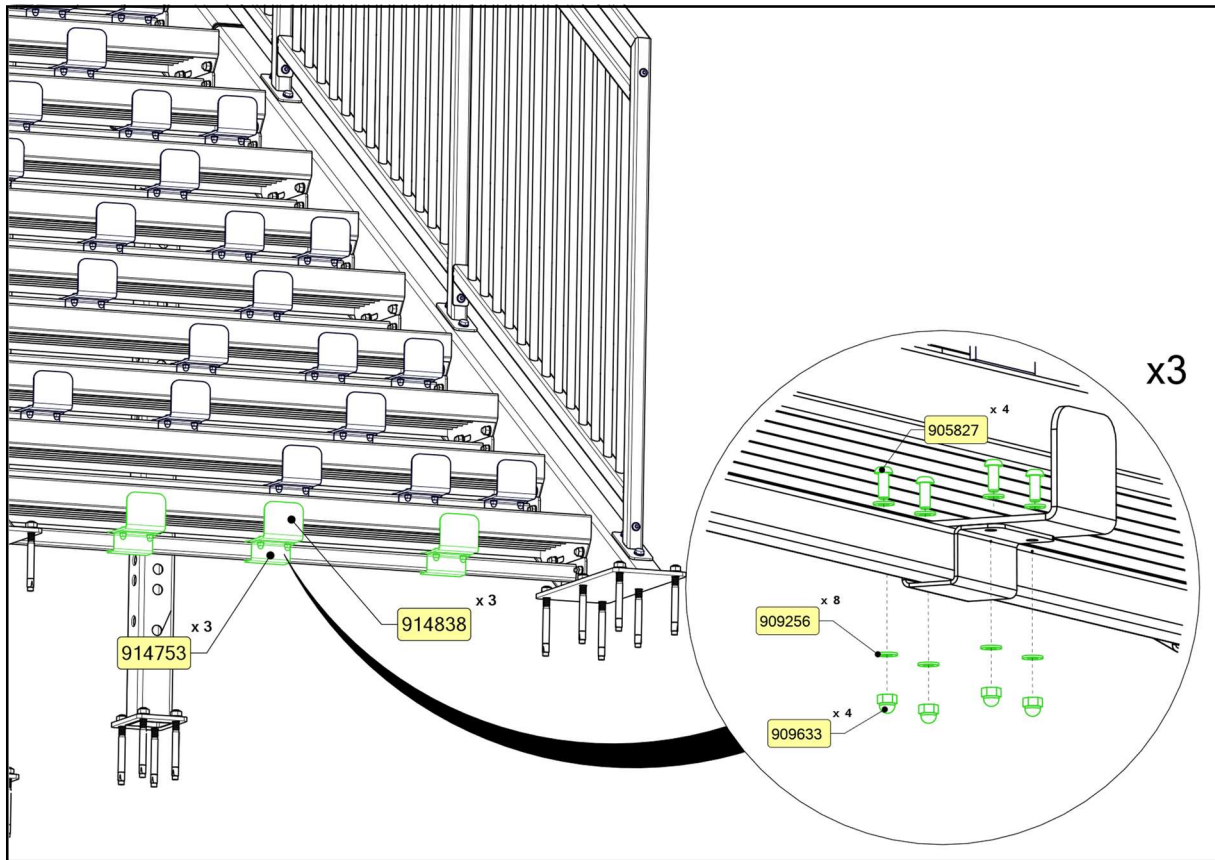

## SISU FITNESS STAIRS

### COUNTER

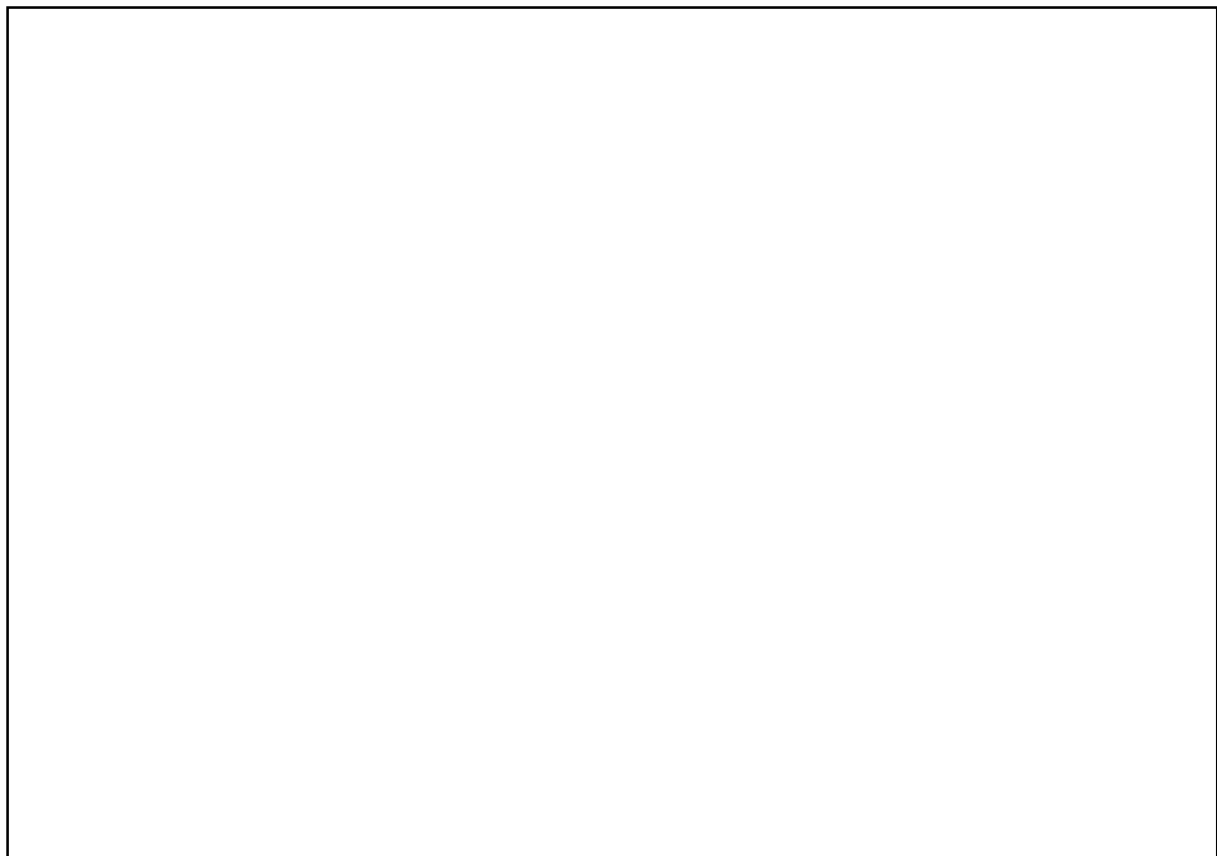
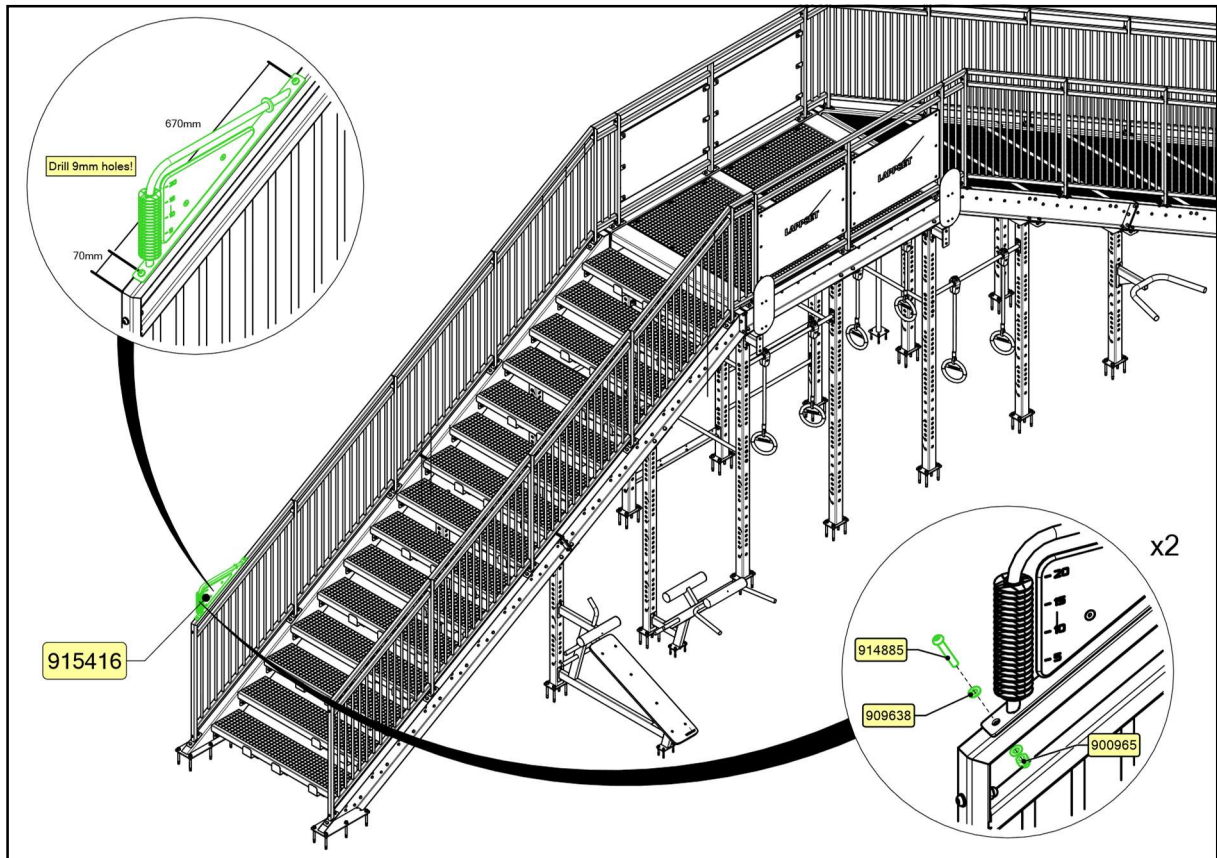

## SISU FITNESS STAIRS

### SIGNS

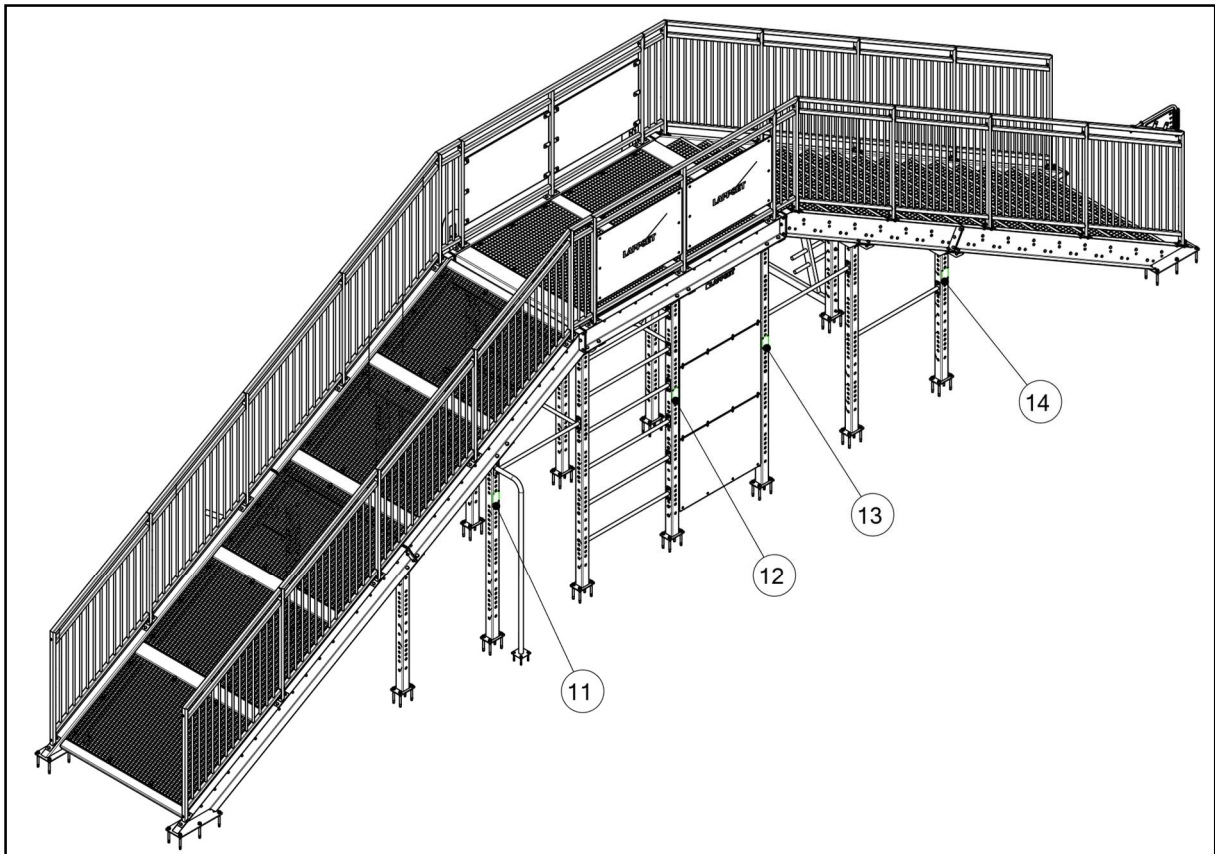
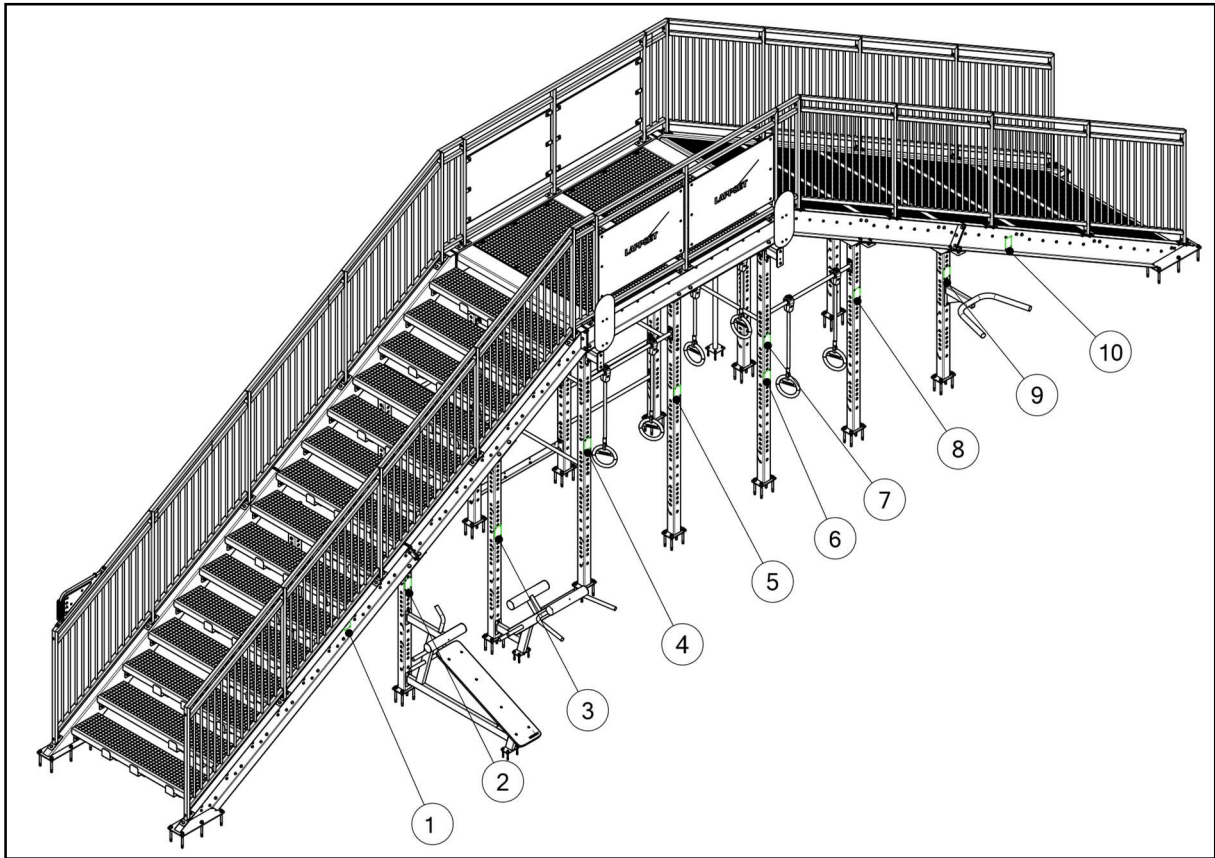

## SISU FITNESS STAIRS

### SIGN 1

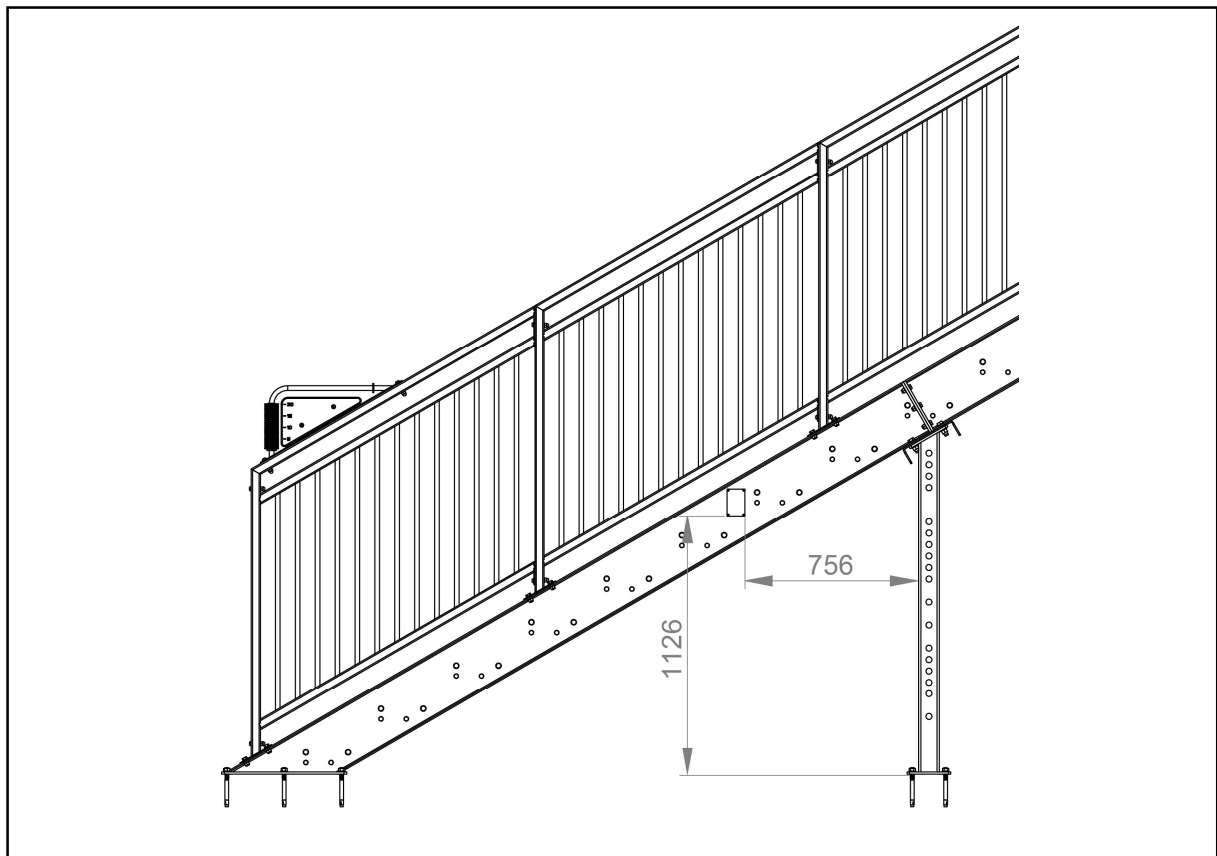
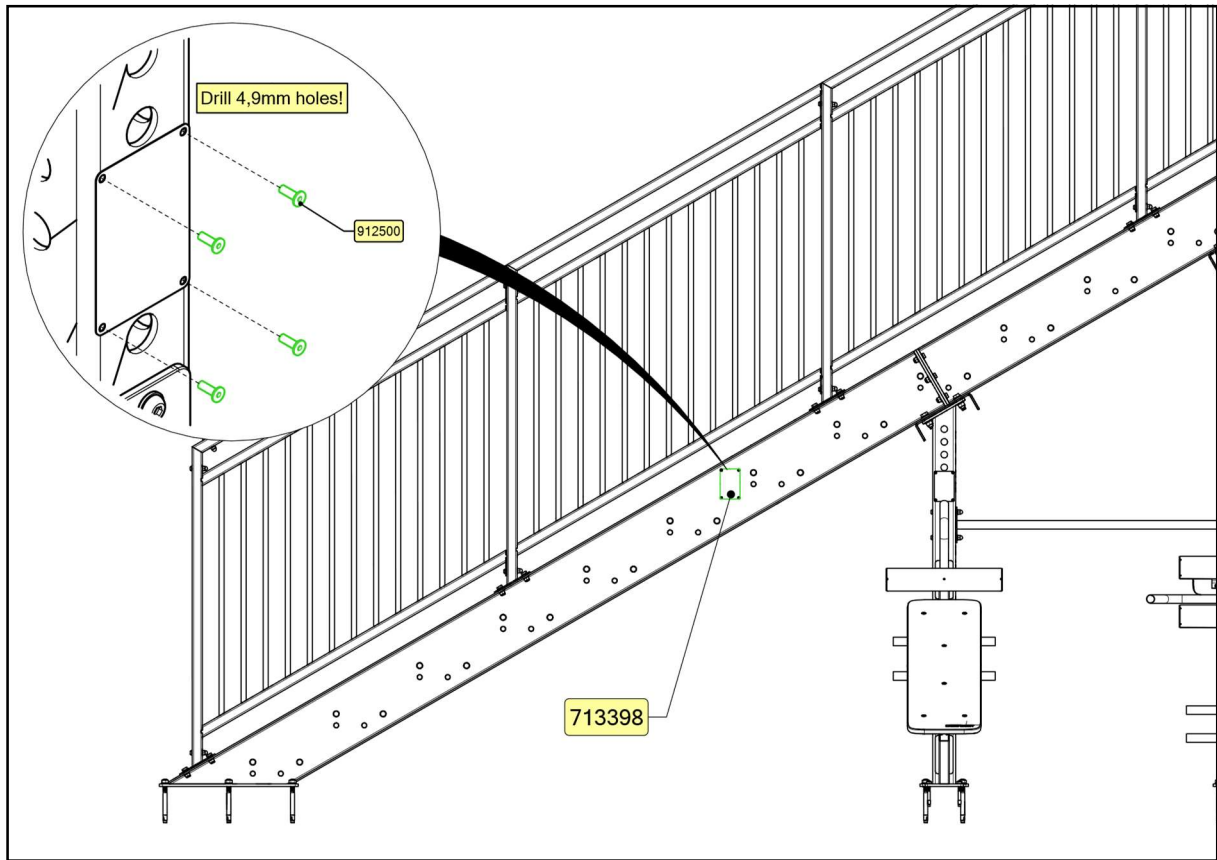

**SISU FITNESS STAIRS**

**SIGN 2**

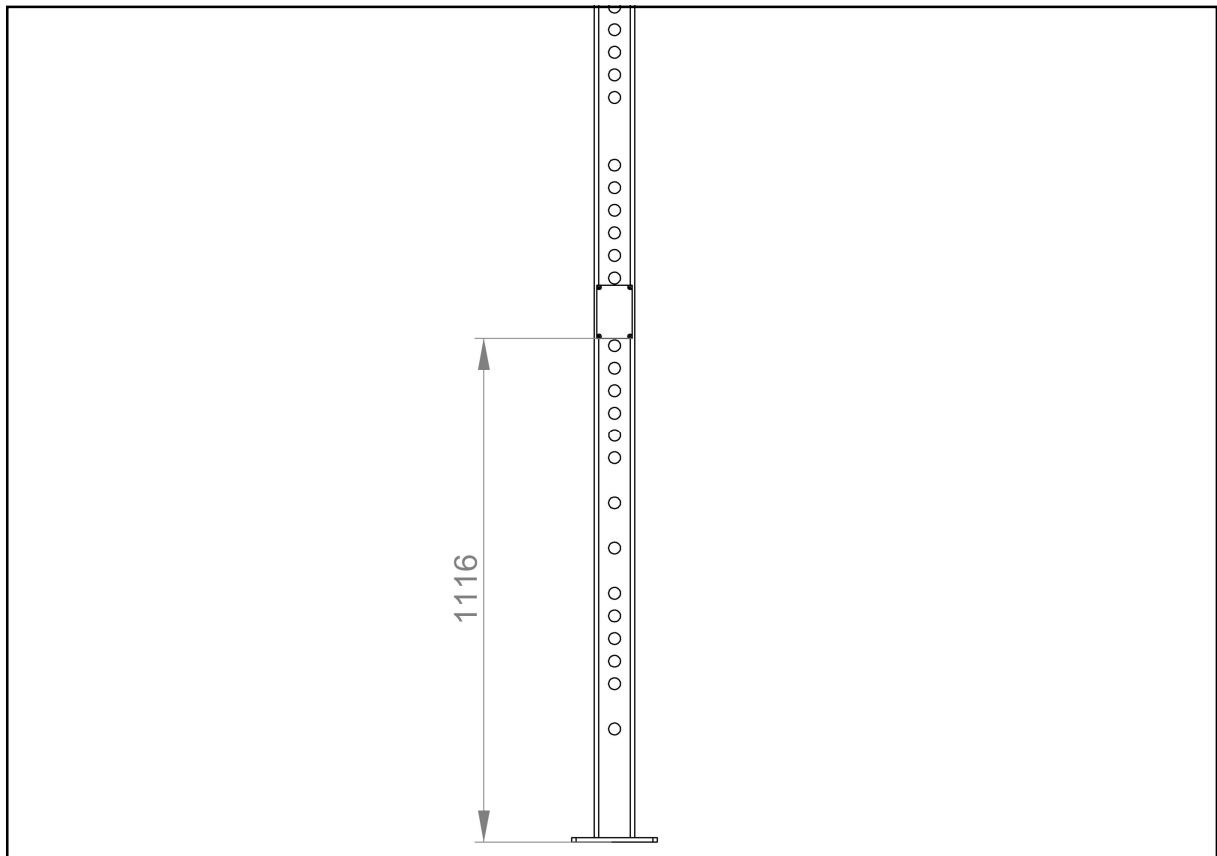
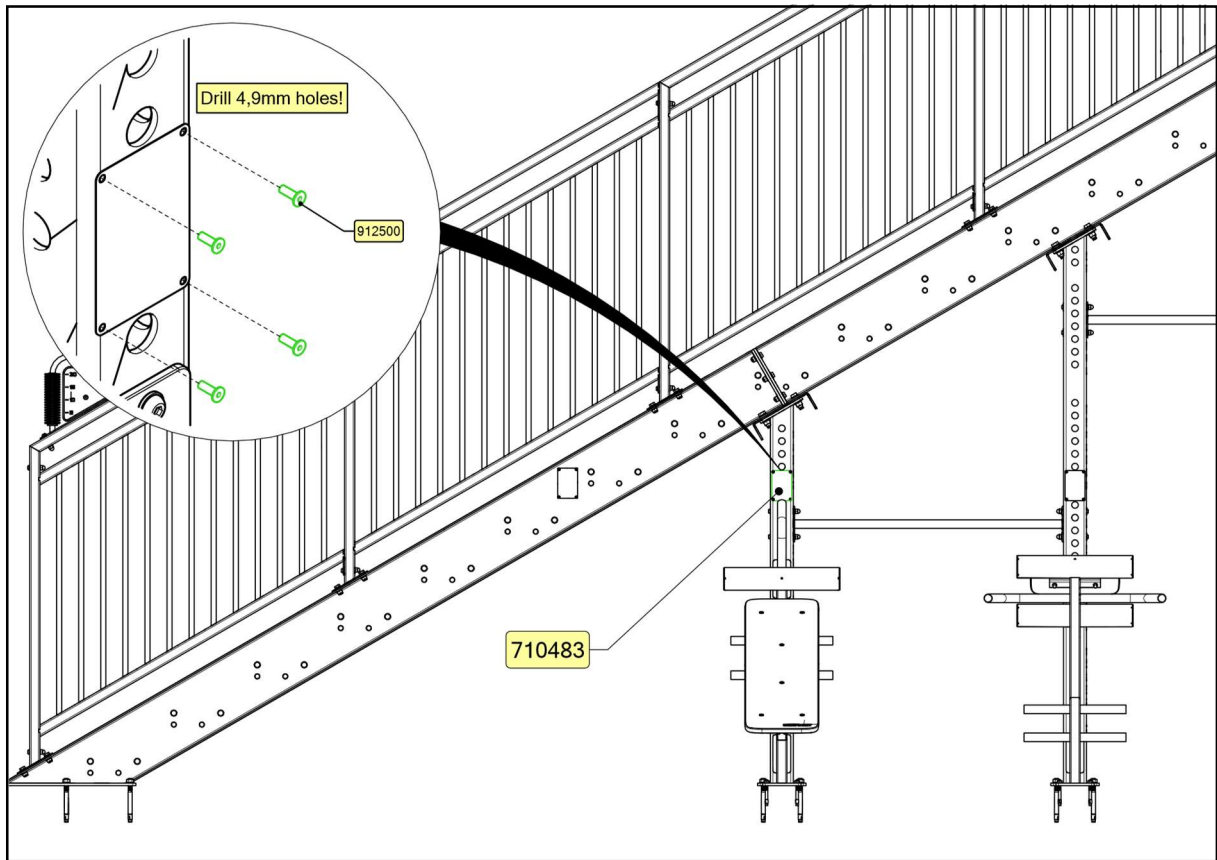

## SISU FITNESS STAIRS

### SIGN 3

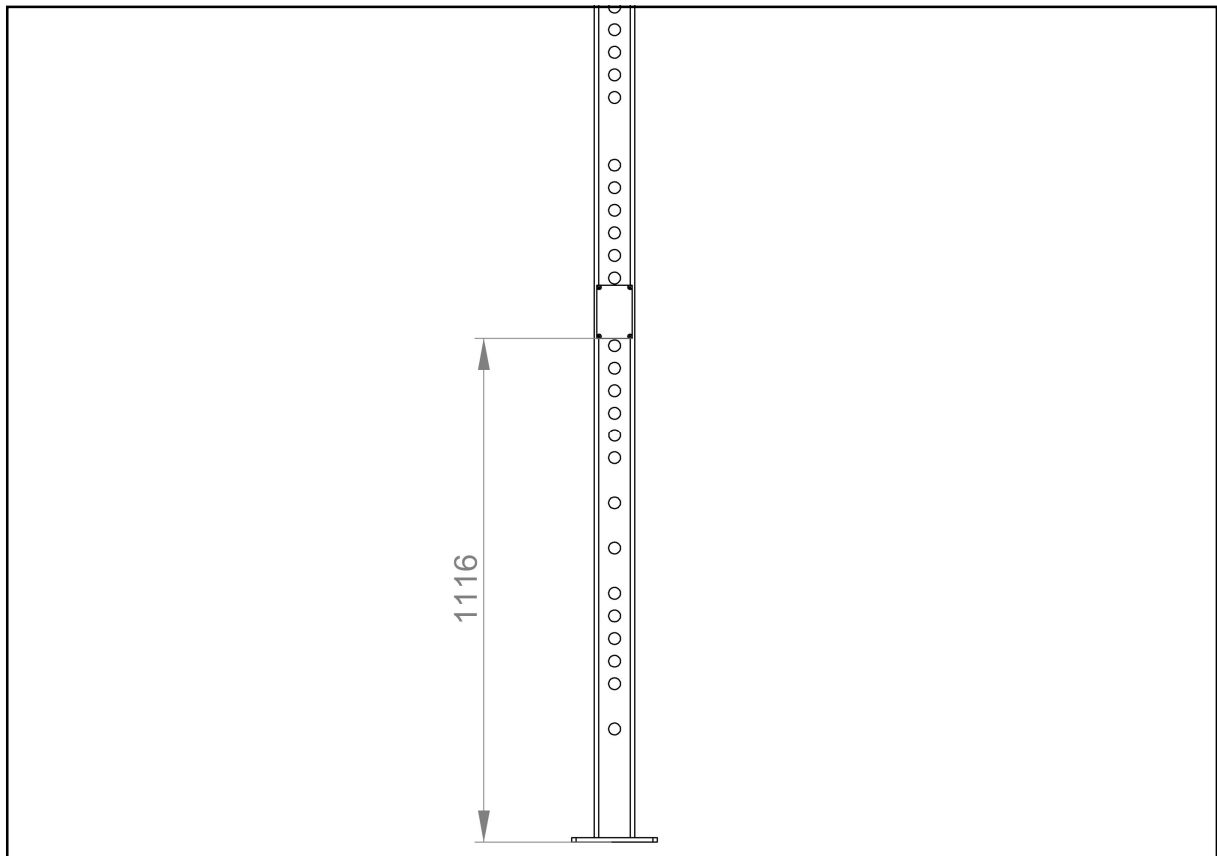
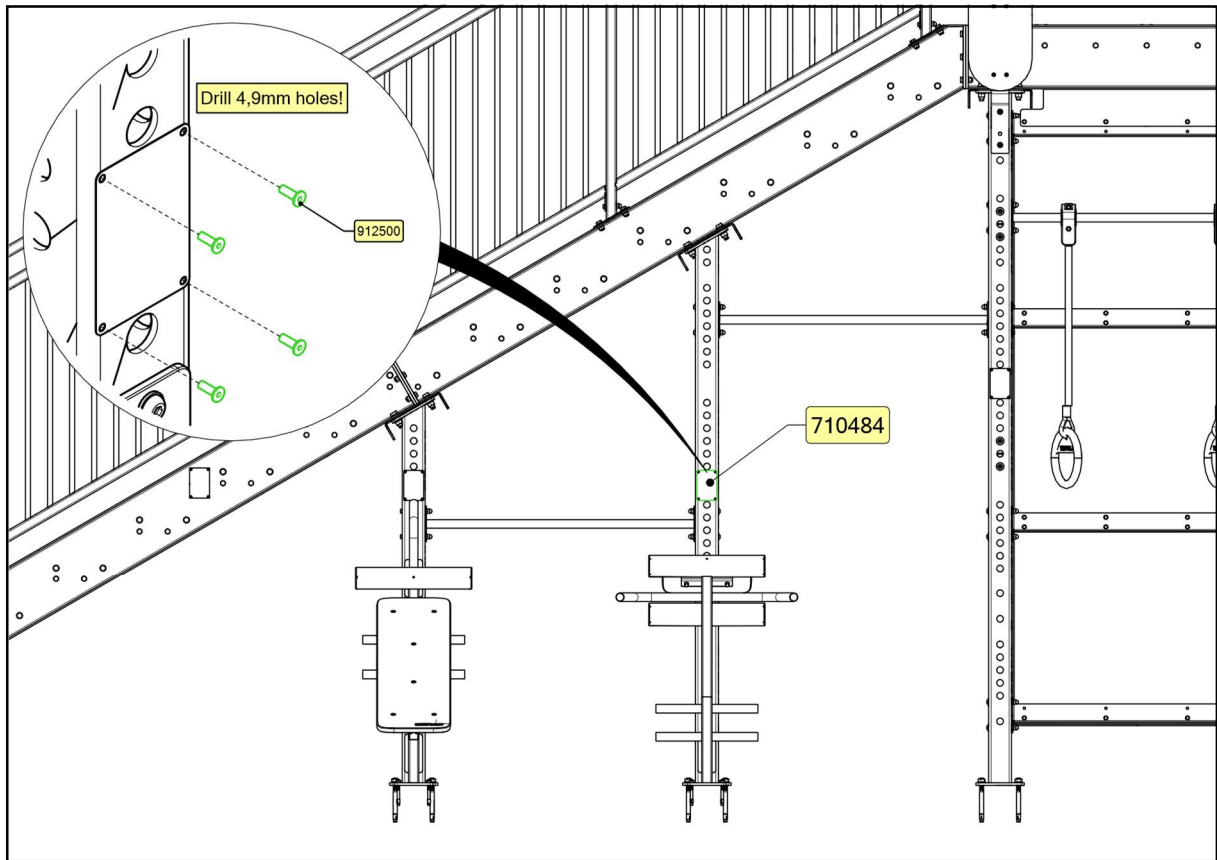

## SISU FITNESS STAIRS

### SIGN 4

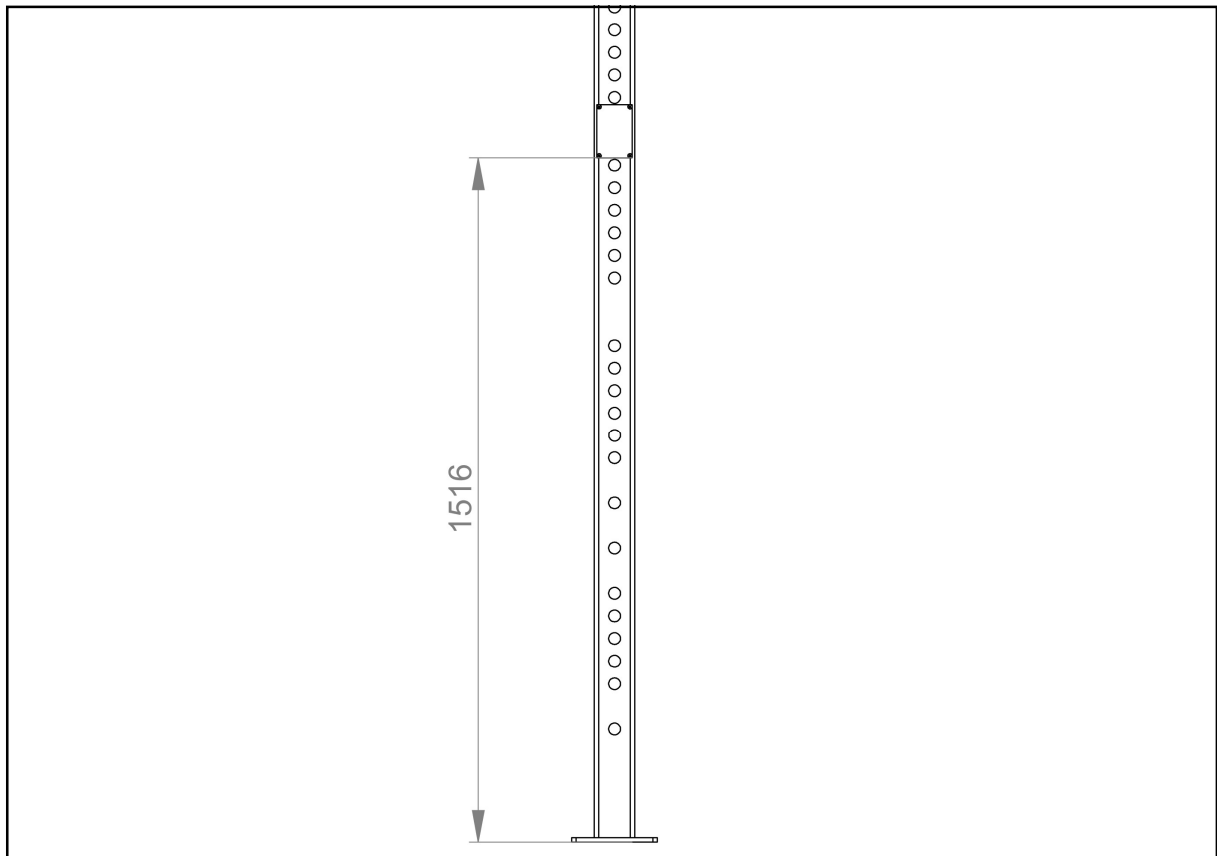
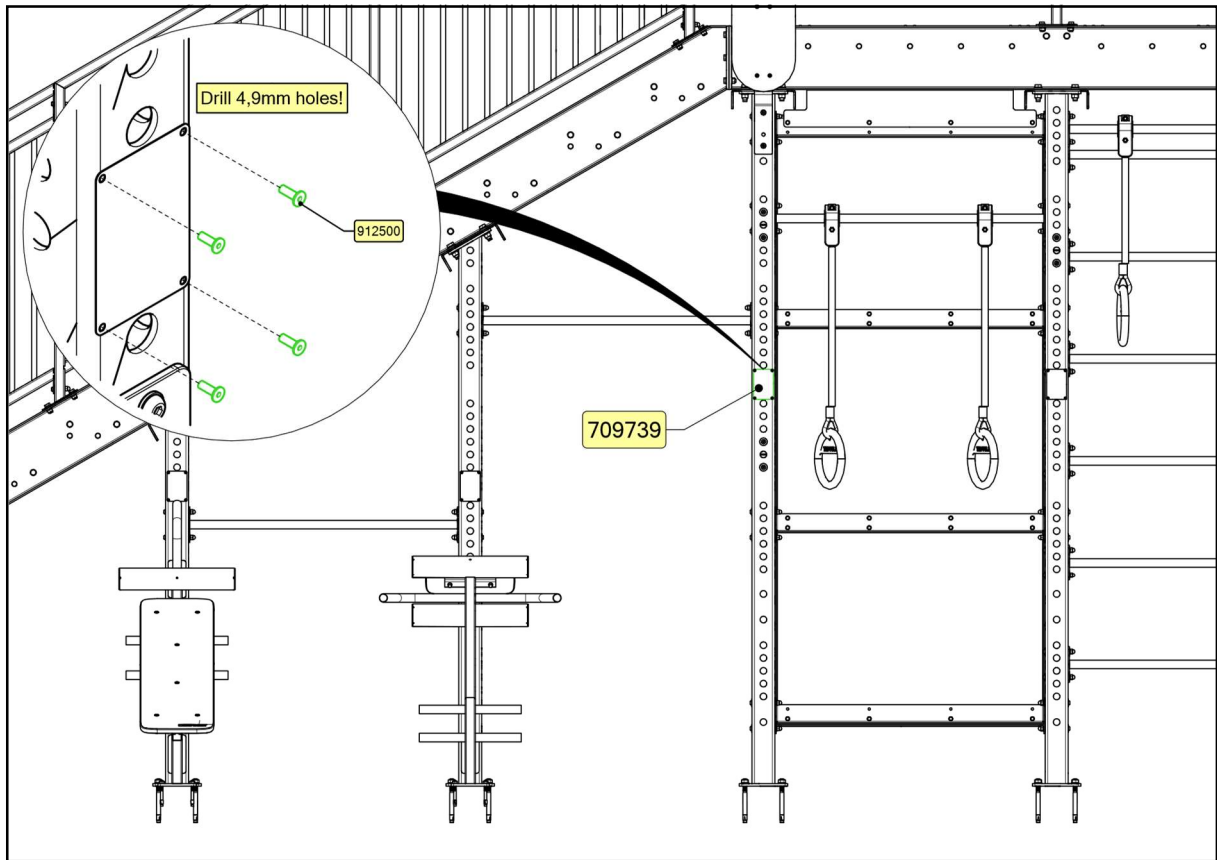

## SISU FITNESS STAIRS

### SIGN 5

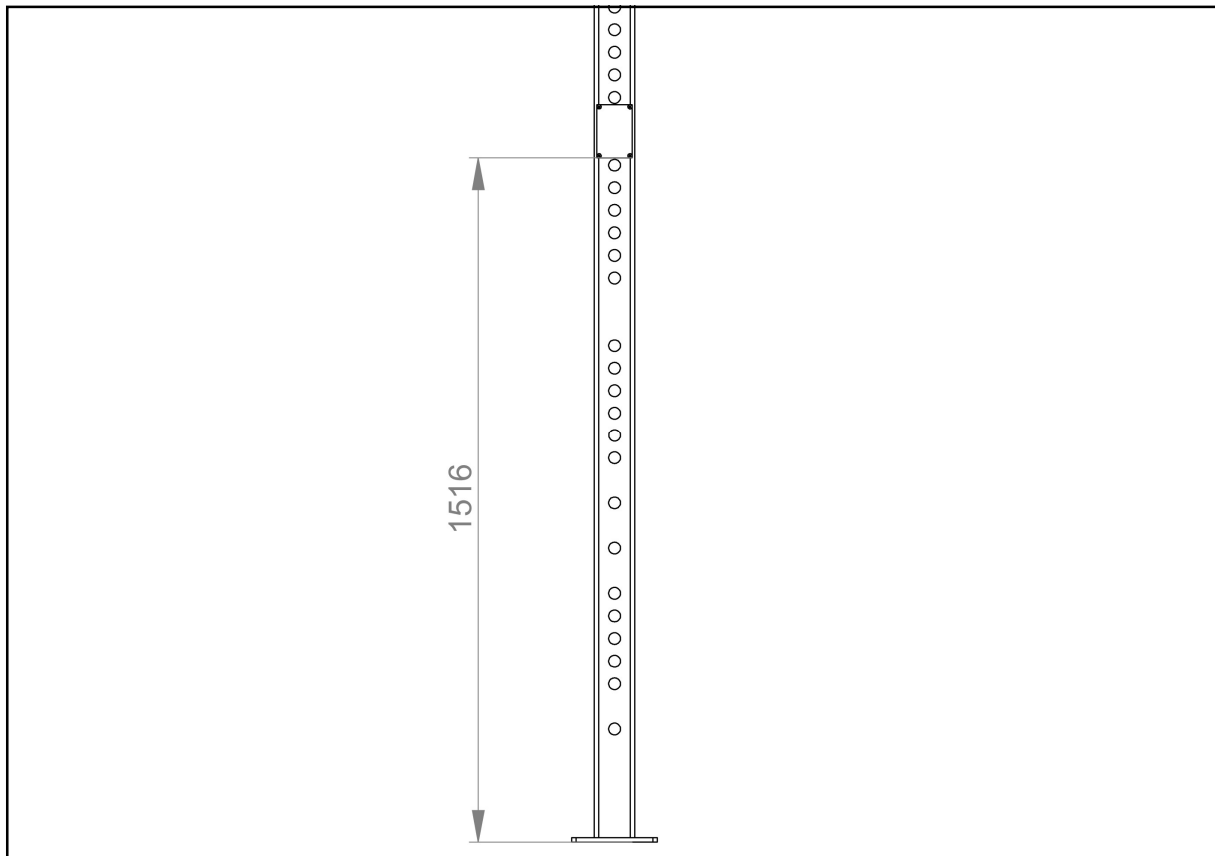
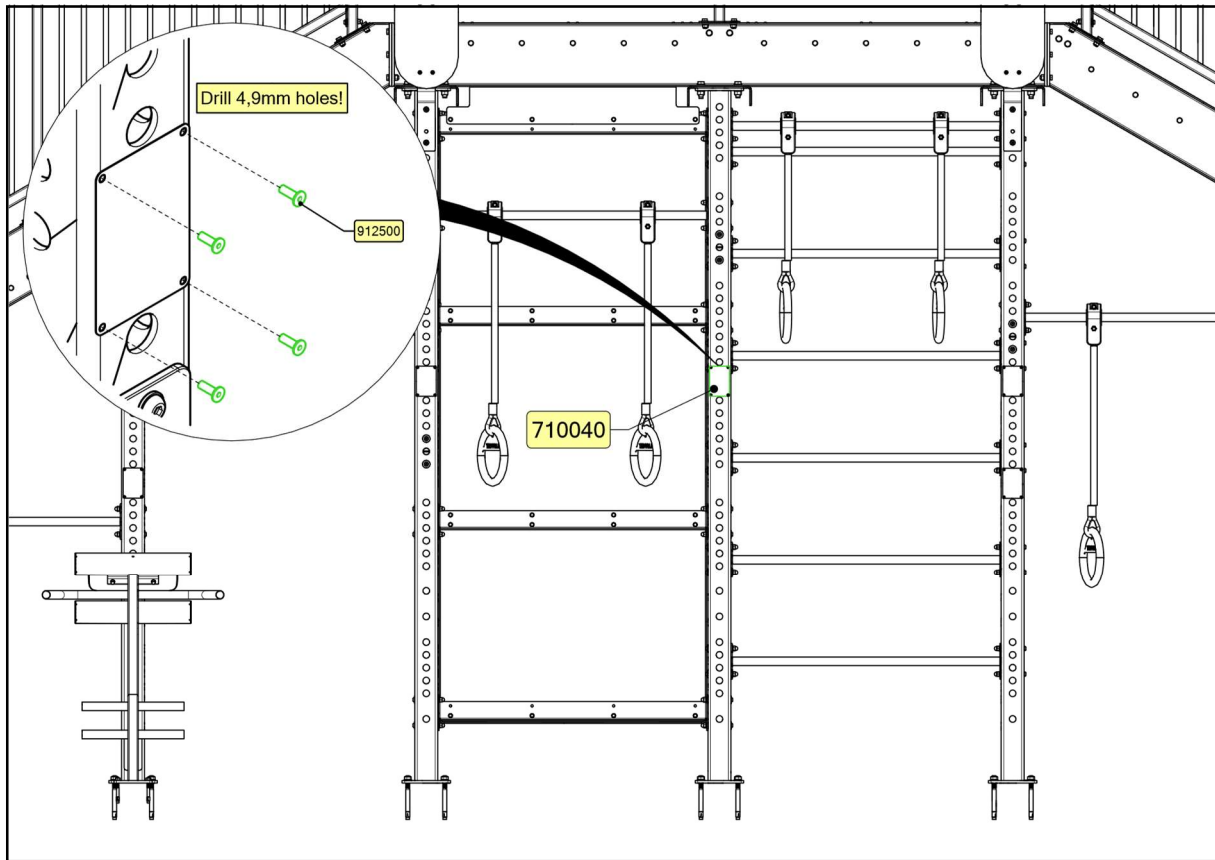

## SISU FITNESS STAIRS

### SIGN 6-7

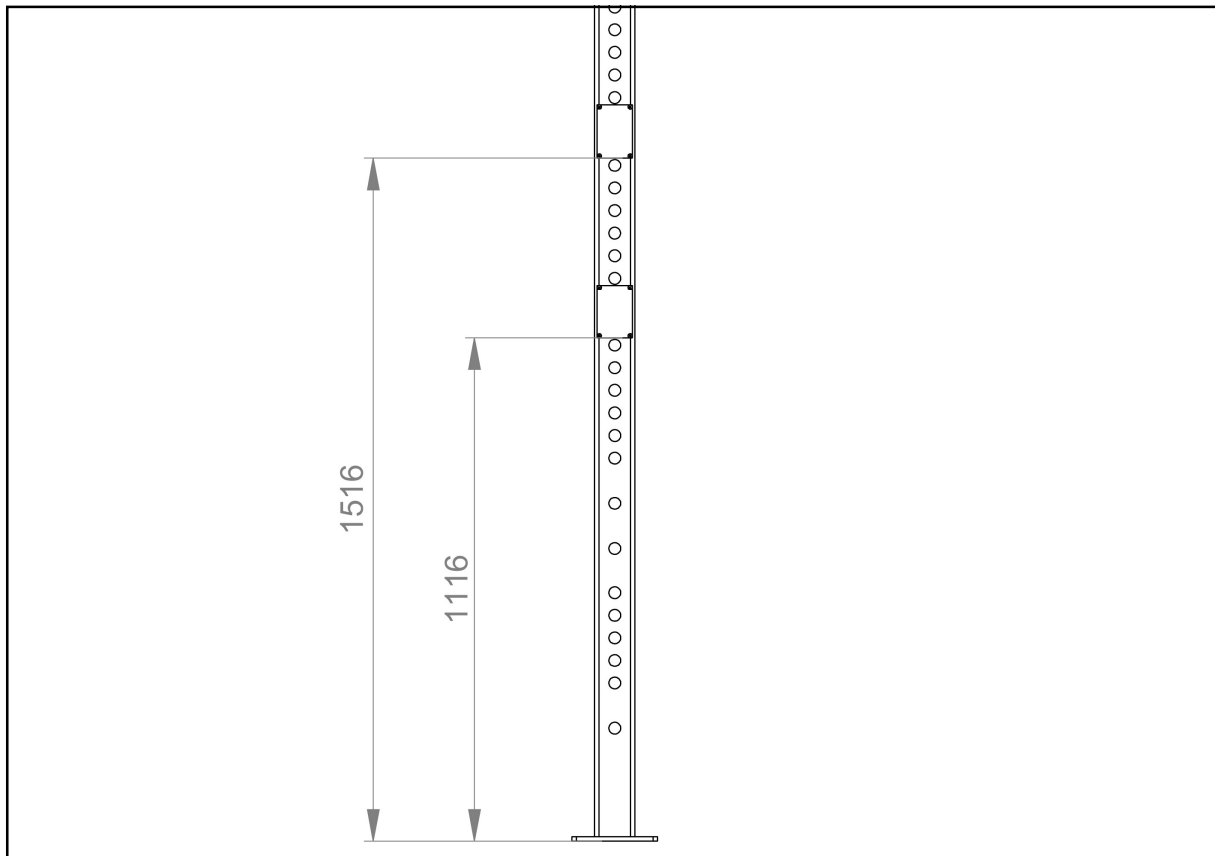
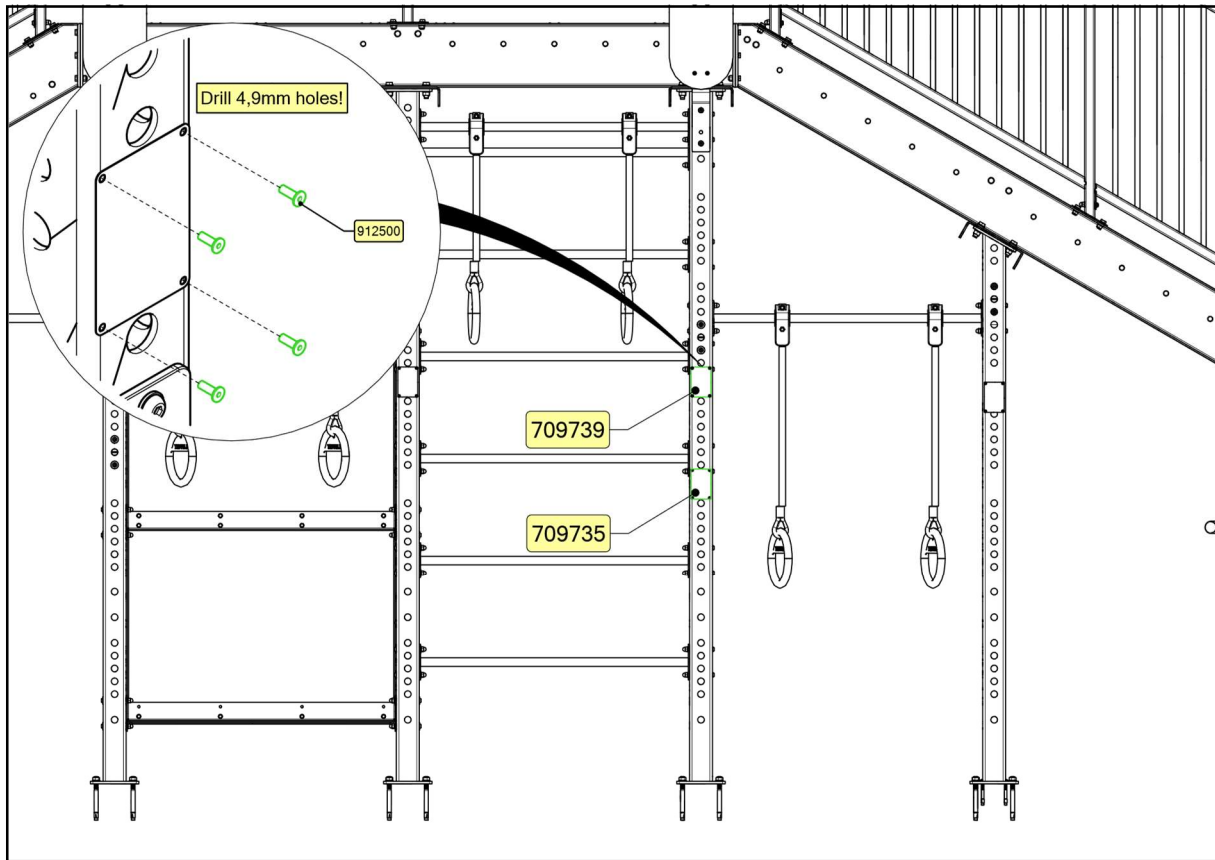

## SISU FITNESS STAIRS

### SIGN 8

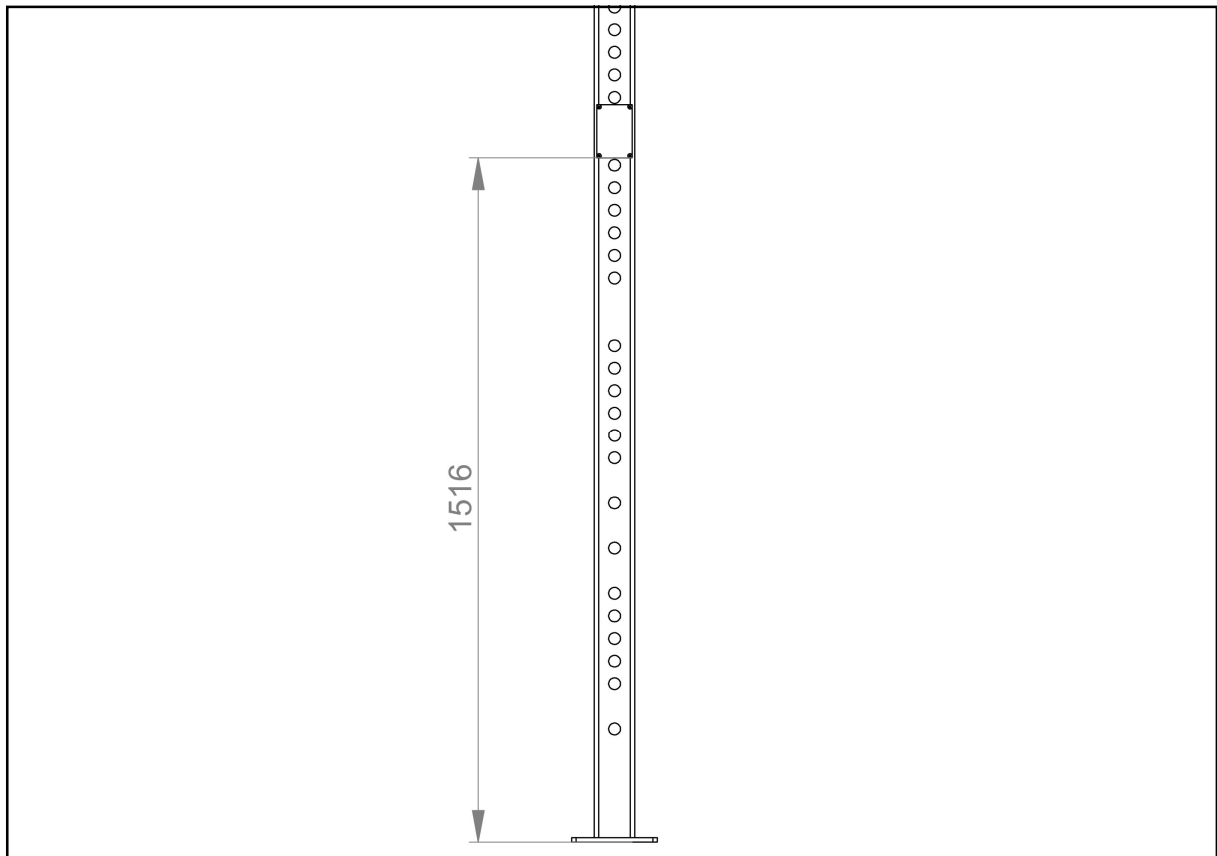
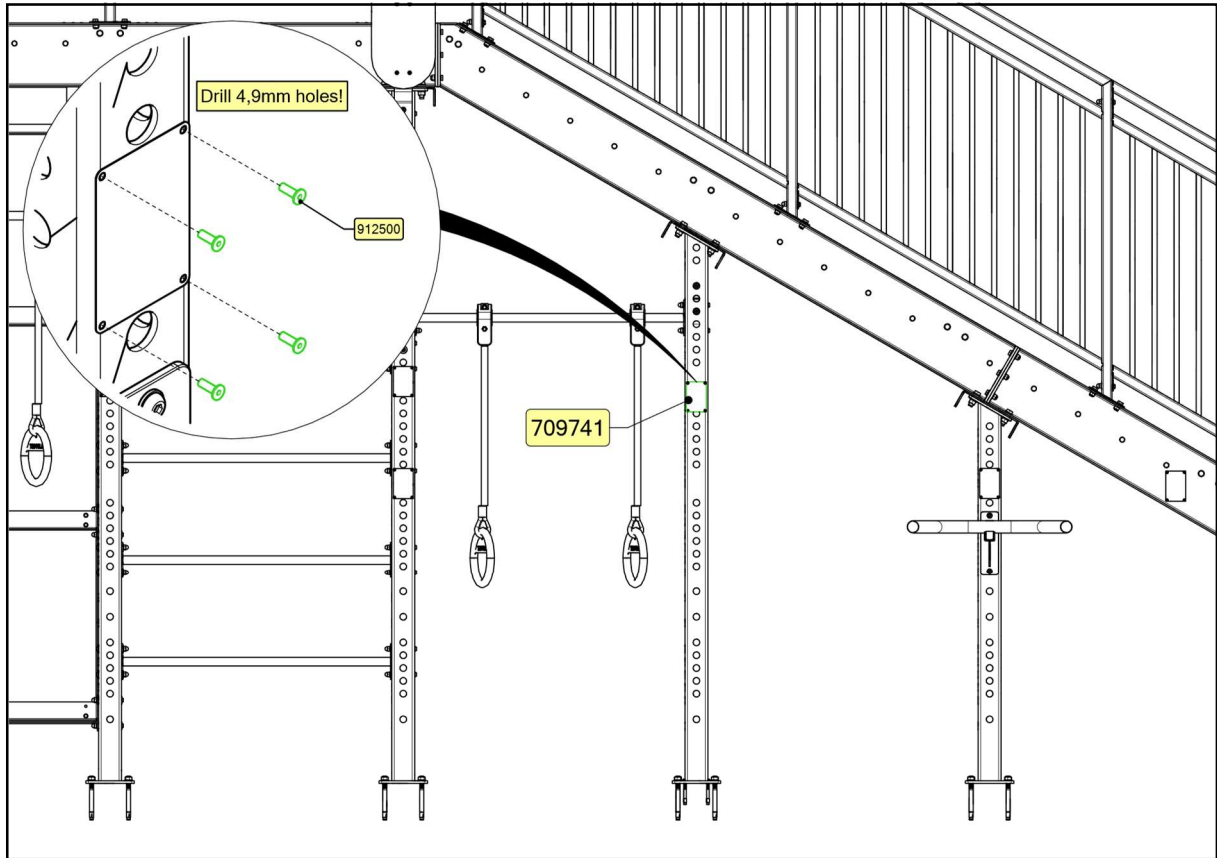

**SISU FITNESS STAIRS**

**SIGN 9**

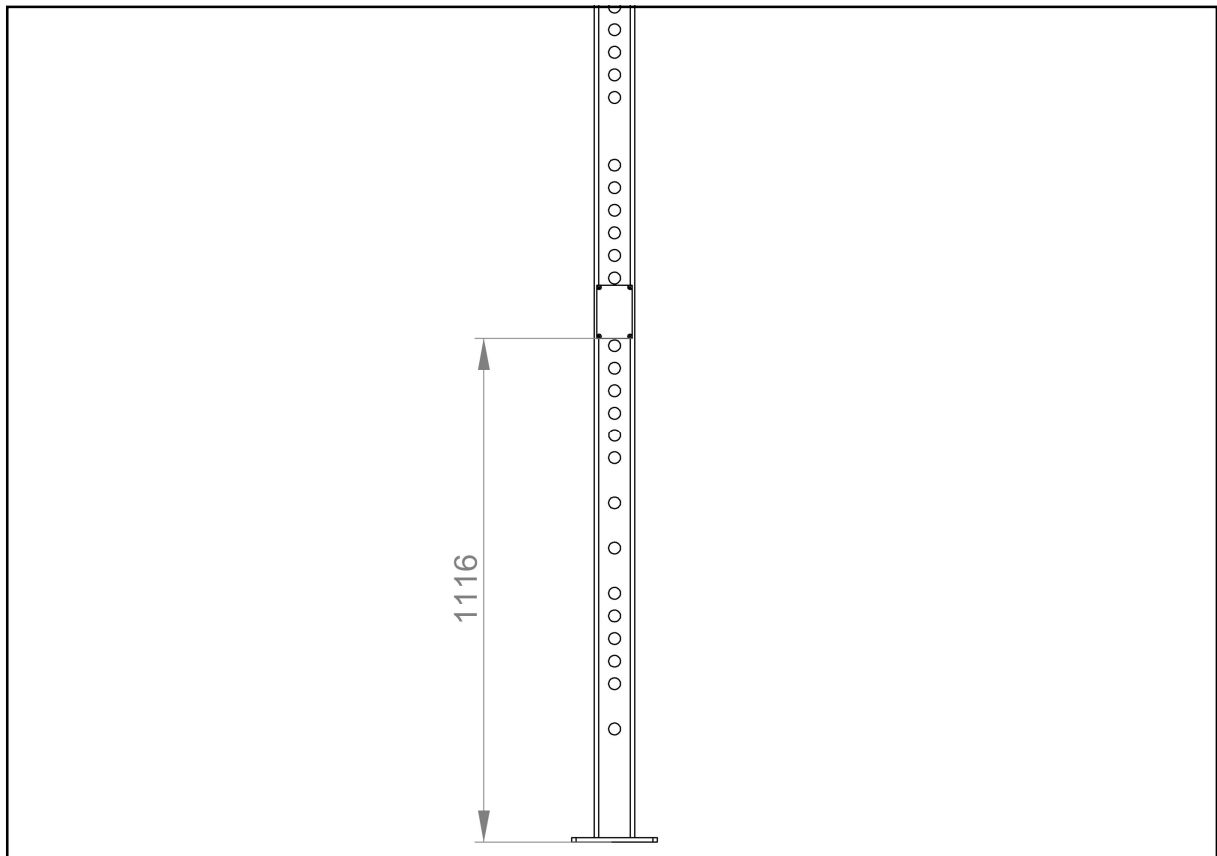
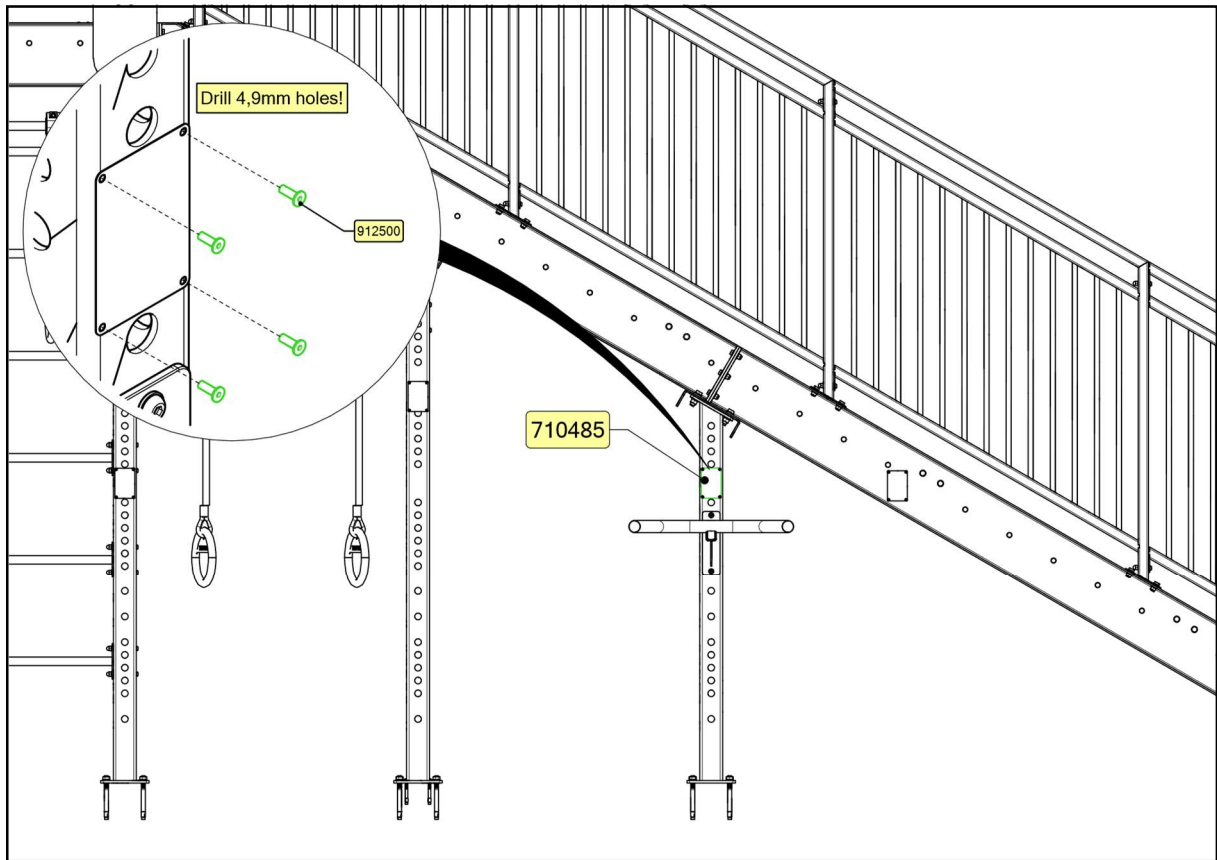

## SISU FITNESS STAIRS

### SIGN 10

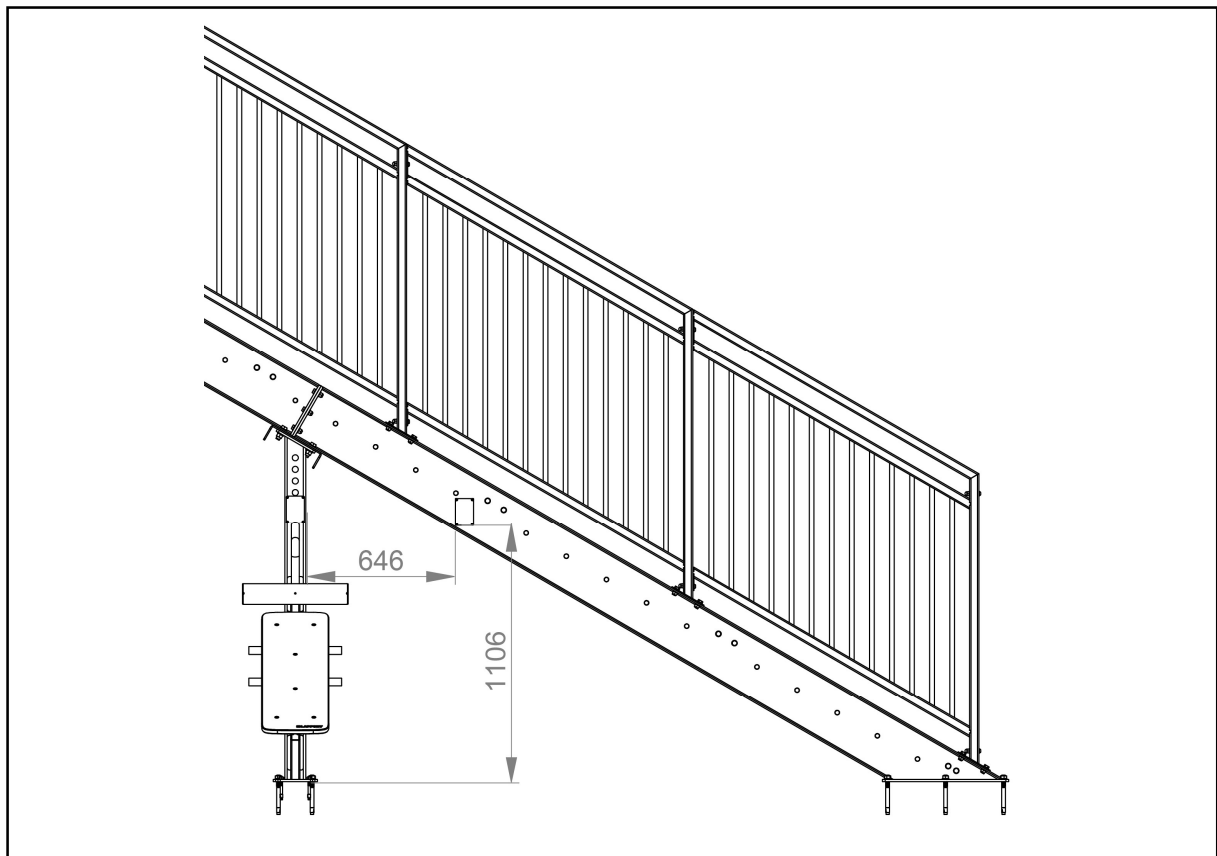
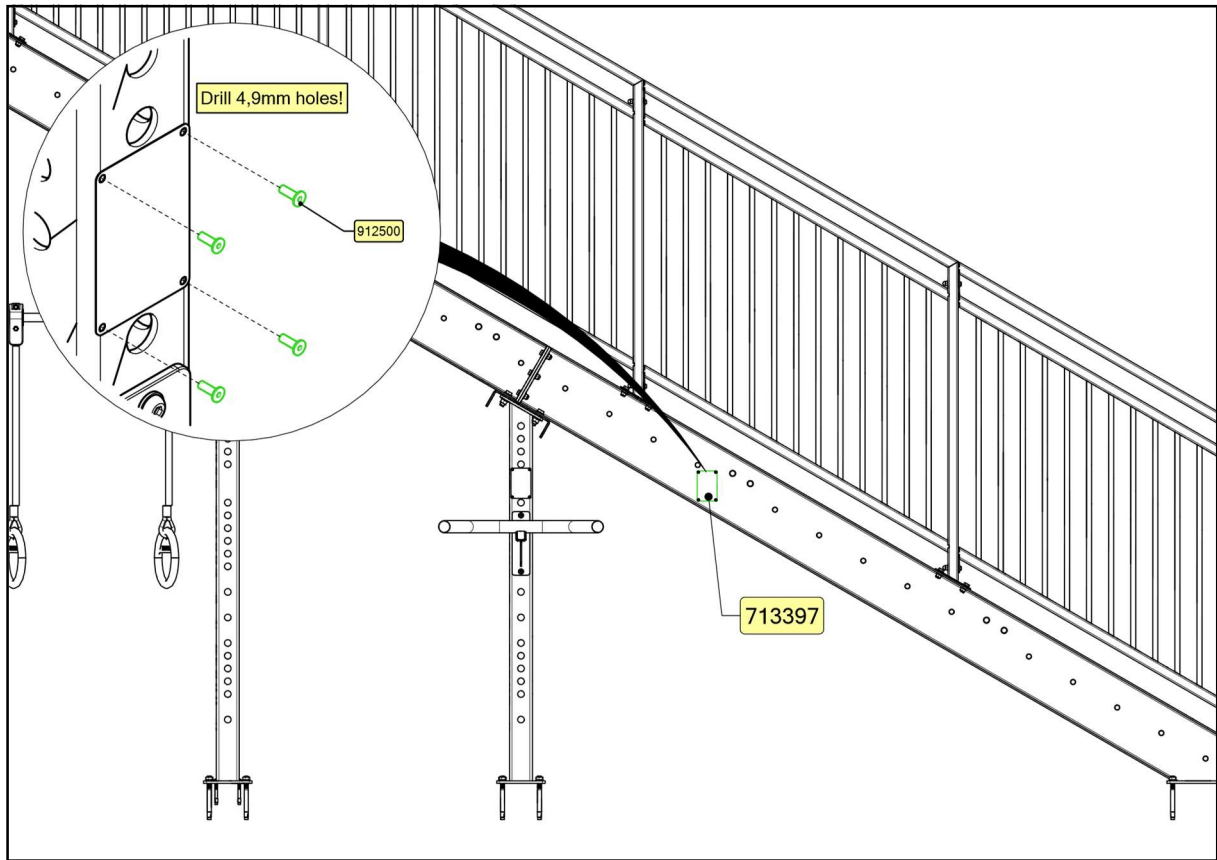

## SISU FITNESS STAIRS

### SIGN 11

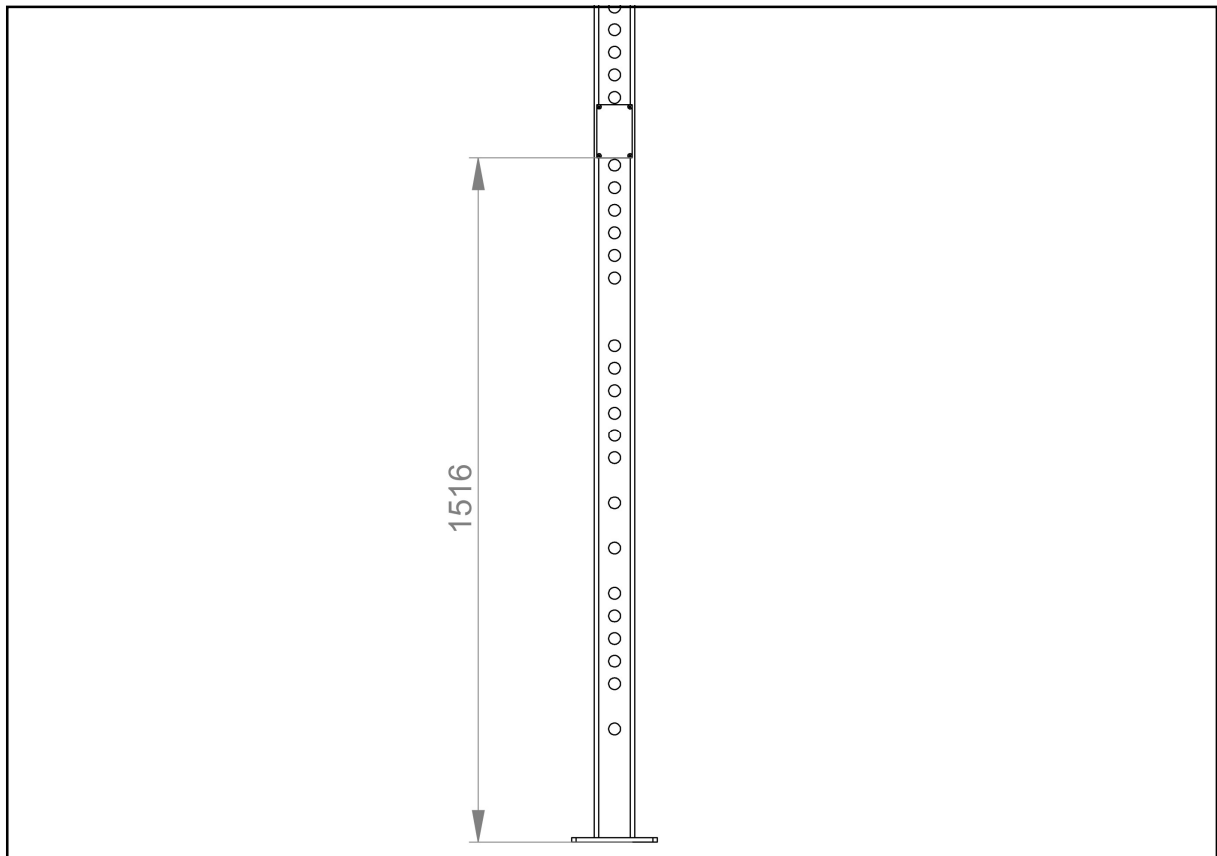
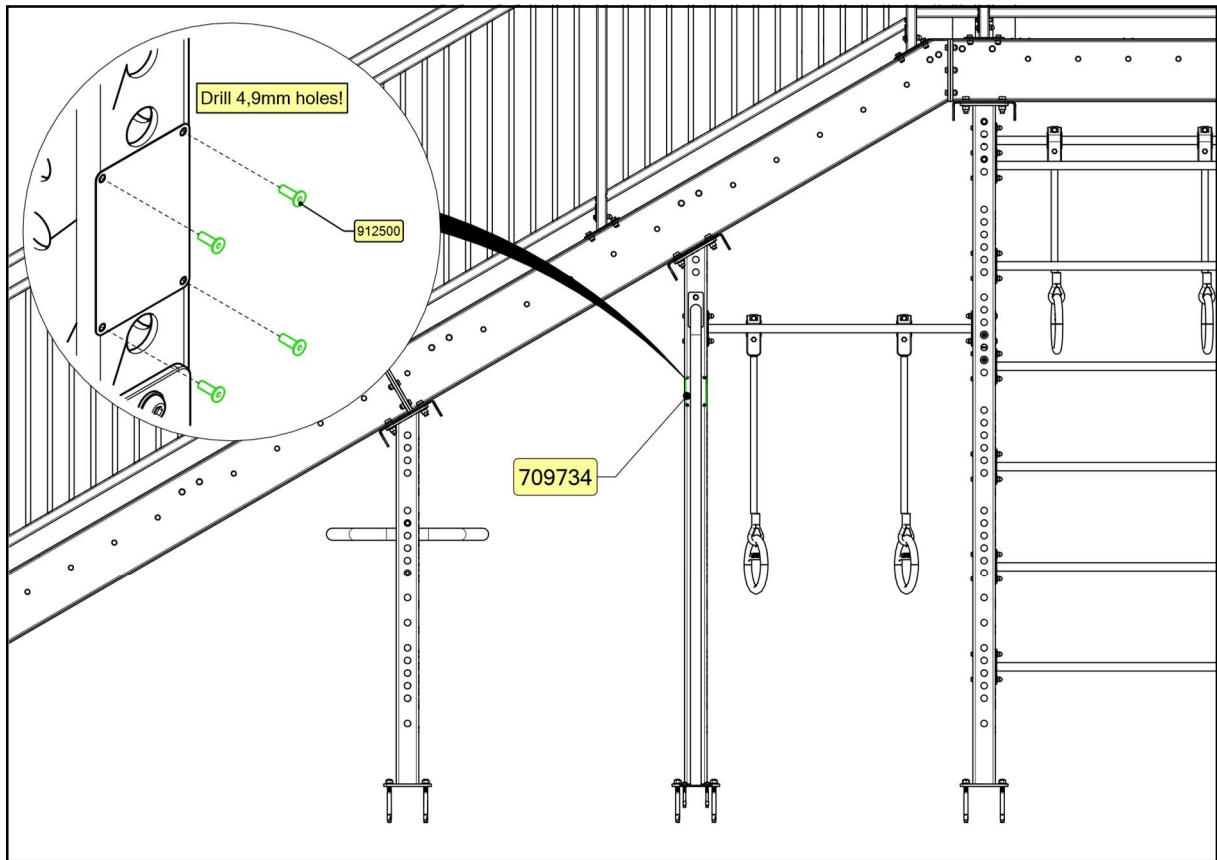

## SISU FITNESS STAIRS

### SIGN 12

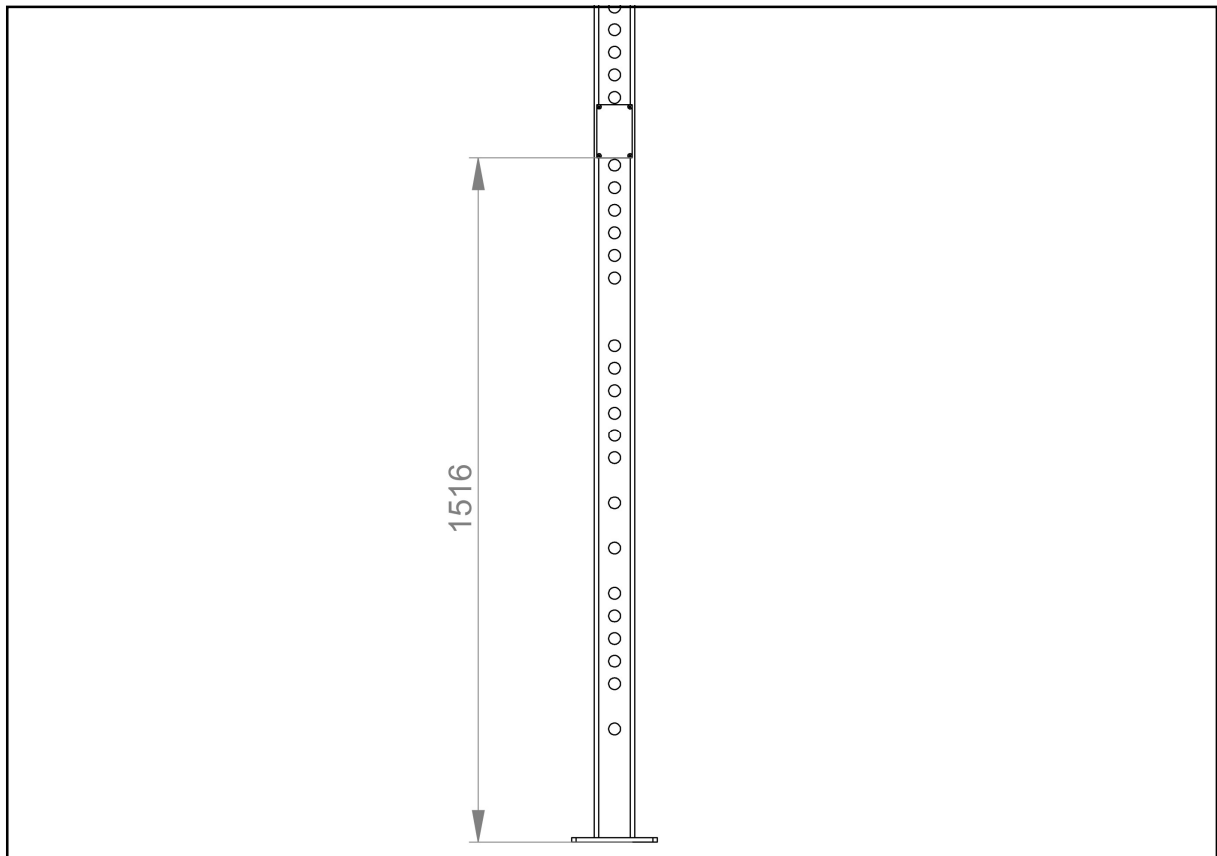
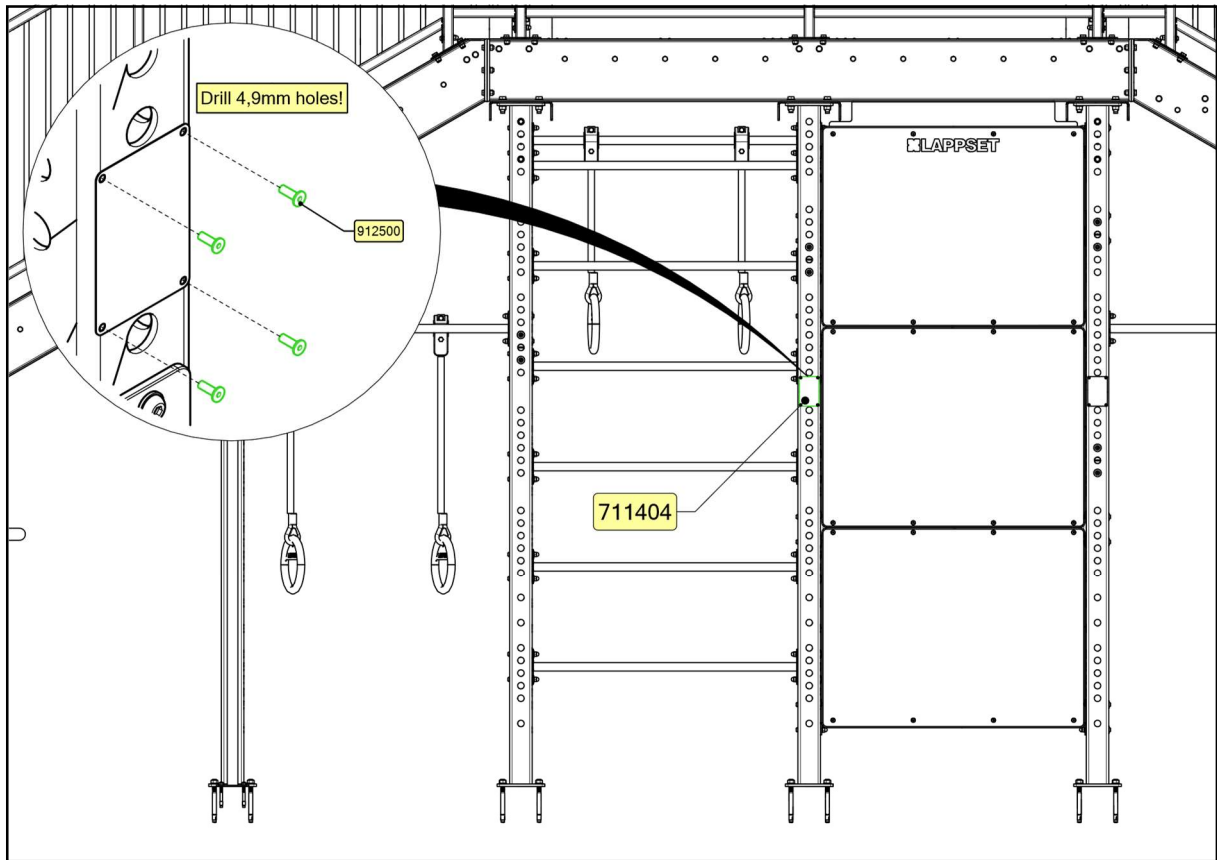

## SISU FITNESS STAIRS

### SIGN 13

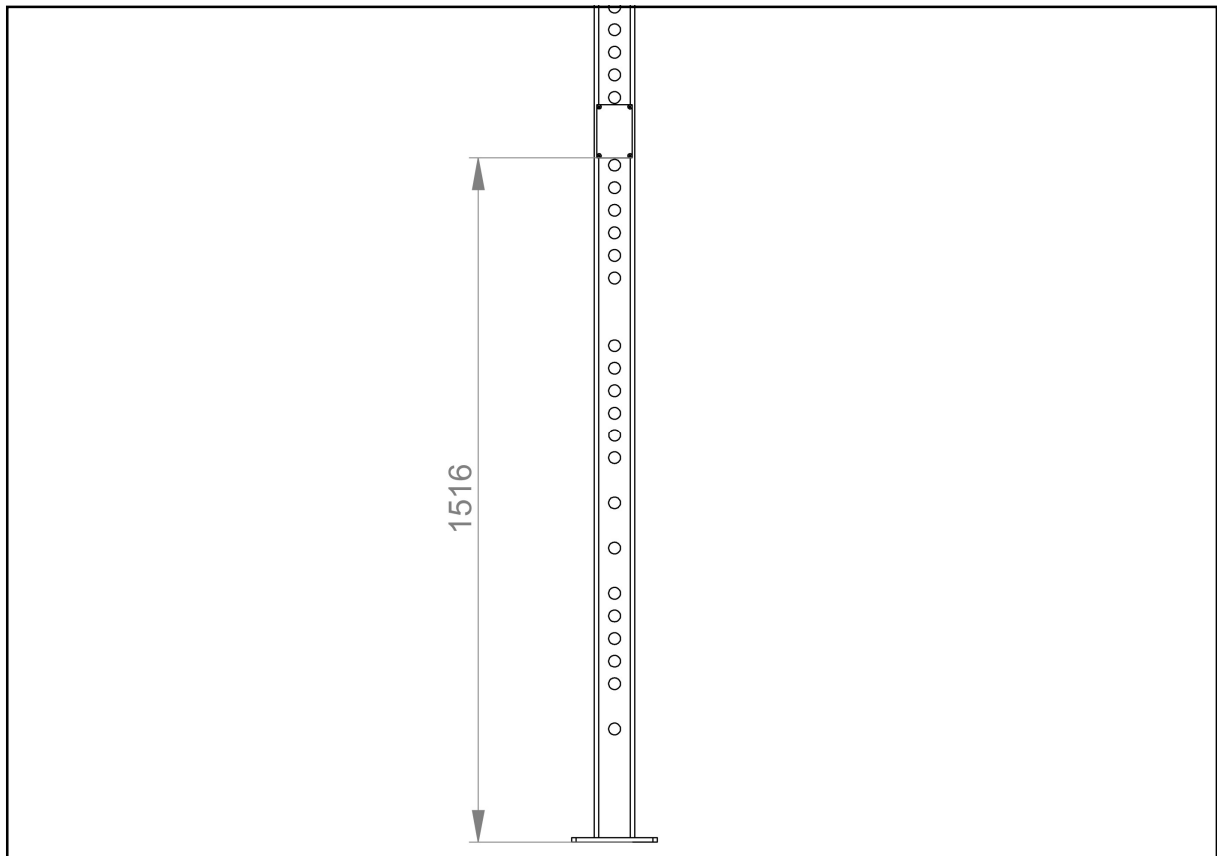
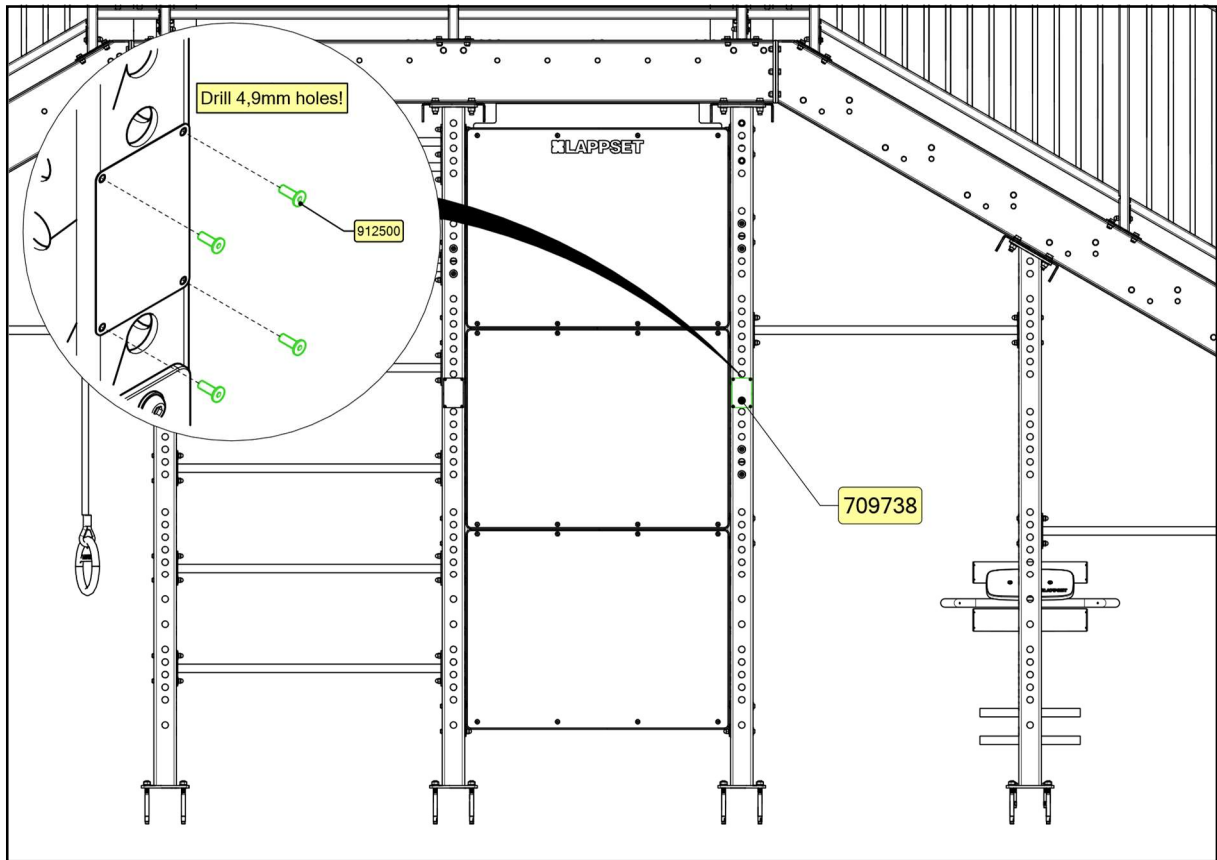

## SISU FITNESS STAIRS

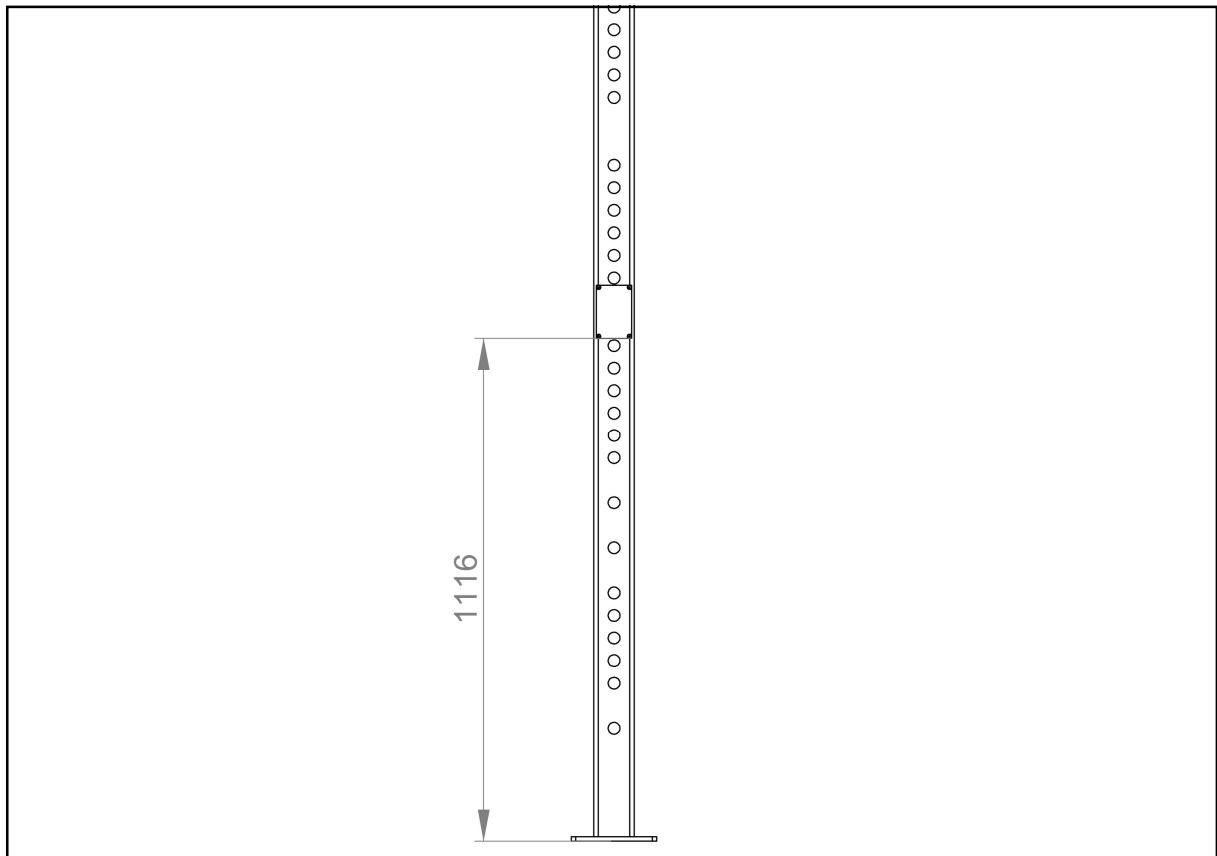
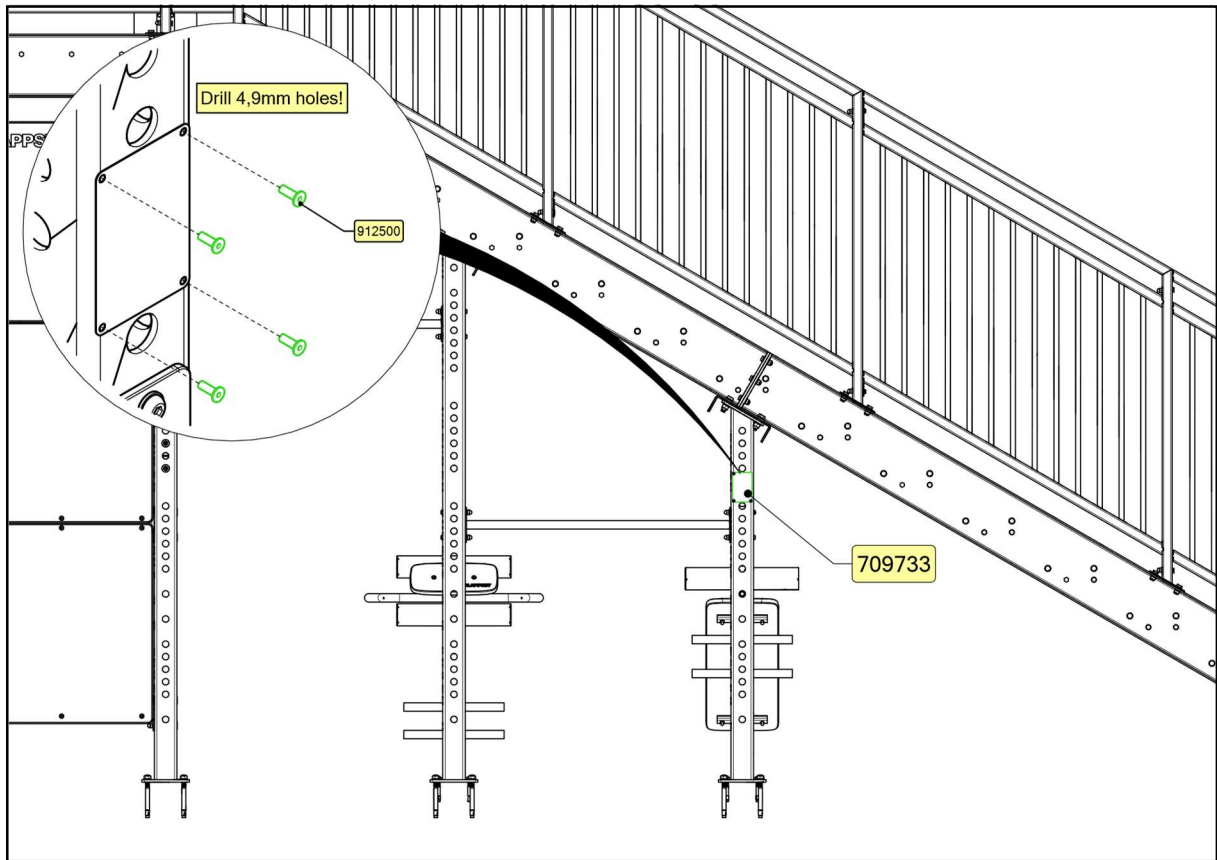

### SIGN 14

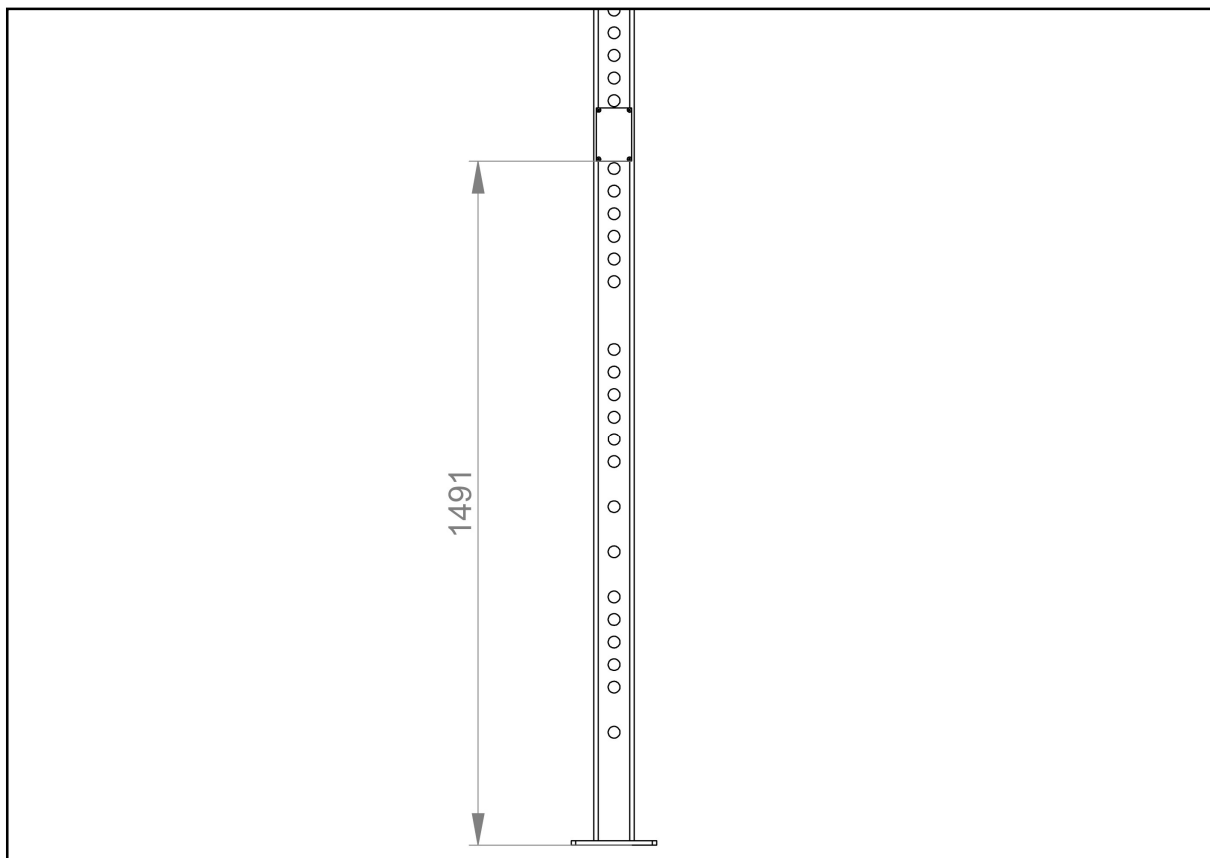
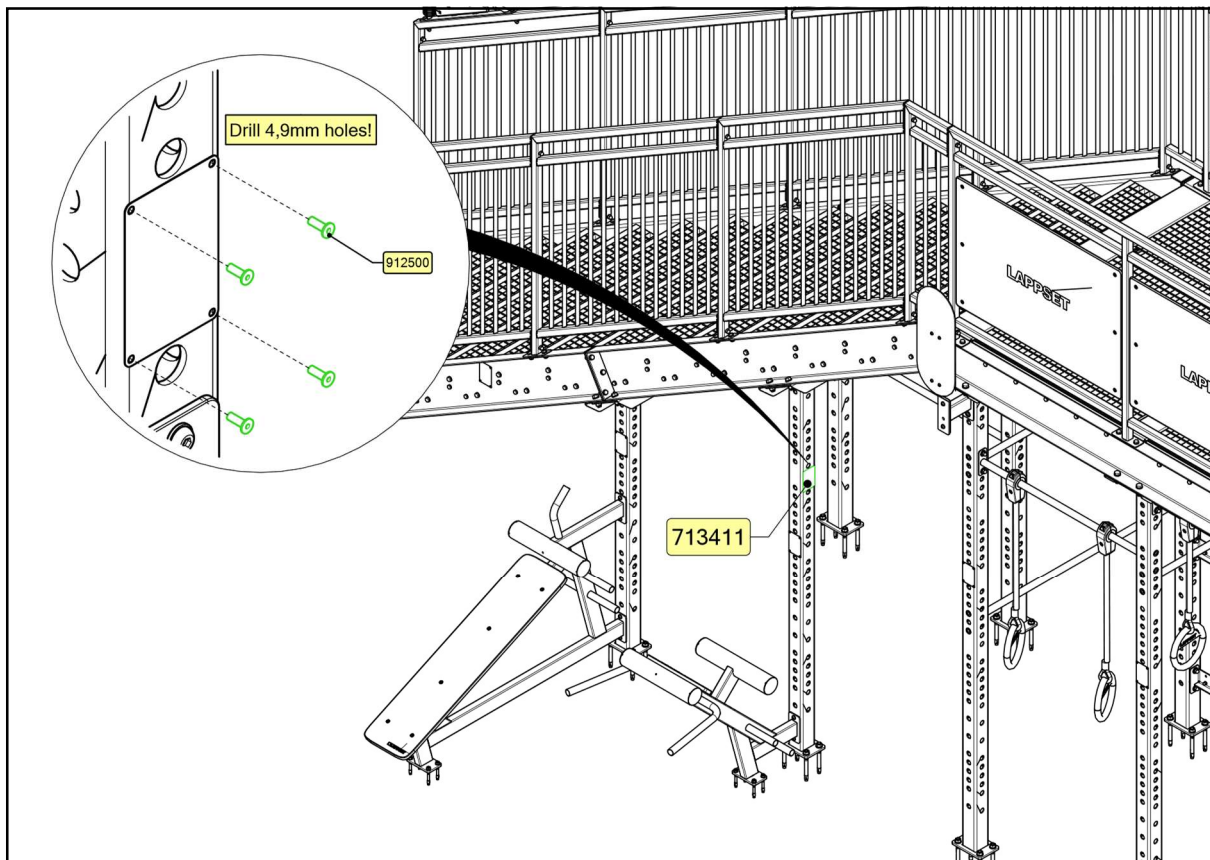

## SISU FITNESS STAIRS

### PRODUCT SIGN

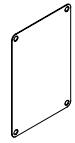

①	SIGN	PCS	②	905390	PCS
 118x78		1	 Ø4,8x28		4

