

SISU FITNESS STAIRS

INSTALLATION MANUAL

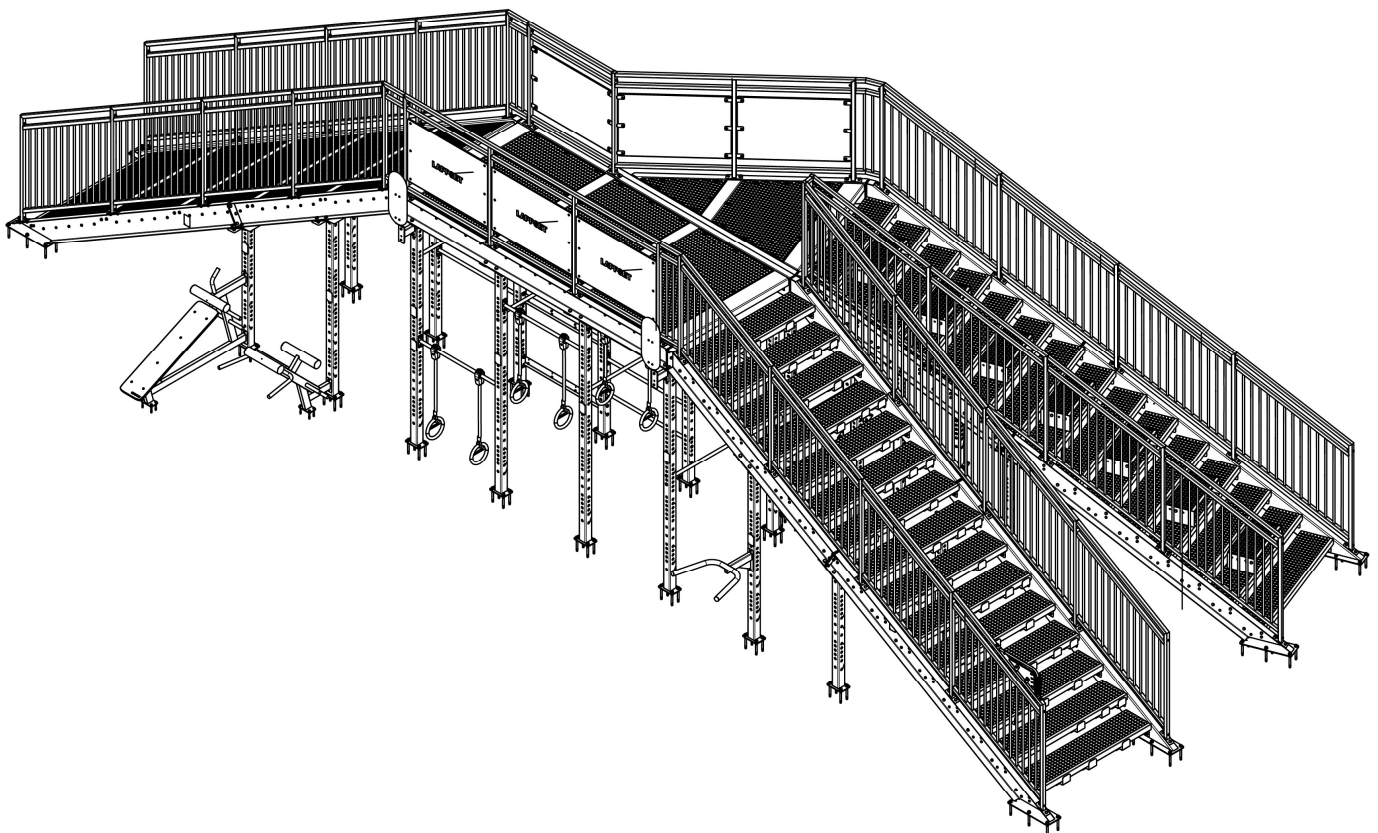

081875M

SISU FITNESS STAIRS

PART LIST & FASTENING ACCESSORIES

ITEM NO.	PART NUMBER	DESCRIPTION	QTY.
1	709733	SIGN, PULLUP	1
2	709734	SIGN, DRAGON FLAG	1
3	709735	SIGN, GIANT	1
4	709738	SIGN, HANDWALK	1
5	709739	SIGN, BALLWALL	2
6	710040	SIGN, PULLUP	1
7	710483	SIGN, SIT-UP	1
8	710484	SIGN, BACK EXTENSION	1
9	710485	SIGN, DIP	1
10	711404	SIGN, HUMAN FLAG	1
11	712320	LAMINATE	6
12	712464	ROPE ELEMENT	4
13	712467	ROPE ELEMENT	2
14	712495	LAMINATE	2
15	712496	LAMINATE	1
16	713396	SIGN, RING PUSH-UP	1
17	713397	SIGN, RAMP	1
18	713398	SIGN, STAIRS	1
19	713399	SIGN, STAIRS WITH EXTRA STEP	1
20	713409	PRODUCT SIGN	1
21	900965	CAP NUT, M10, DIN 986, nyloc rst	174
22	901302	WASHER, (M10), DIN 125, A2	165
23	902195	CLAMP	12
24	902232	ALLEN SCREW, M10x55, A2 + 2 X DELTA GZ	6
25	902233	ALLEN SCREW, M10x30, A2 + 2 X DELTA GZ	6
26	903148	BOLT, M16 x 50, KS, DIN 931 8,8	90
27	903149	BOLT, M12 x 30, KS, DIN 931 5,8	272
28	903158	LOCK NUT, M16, DIN 985, nyloc zn	90
29	904450	ANCHOR, M16x170	120
30	905086	WASHER, DIN 440, HDG	28
31	905827	ALLEN SCREW, M8 x 20	180
32	906006	SLEEVE	12
33	906598	STICKER	1
34	909142	BOLT, M12 x 70, KS, DIN 601 4,6	28
35	909248	LOCK NUT, M12, DIN 985, nyloc zn	321
36	909256	WASHER, (M8), DIN 125, A2	360
37	909349	BOLT, M12 x 40, KS, DIN 601 4,6	45
38	909520	WASHER, (M16), DIN 125, A2	184
39	909628	ANCHOR, M10x100	12
40	909629	BOLT, M10 x 30, KS, DIN 933 8,8	218
41	909633	CAP NUT, M8, DIN 986, A2, nyloc rst	250
40	909637	LOCK NUT, M10, DIN 985, nyloc zn	218
41	909638	WASHER, (M10), DIN 125, HDG	517
42	909644	NUT, M12, DIN 986, nyloc rst	28

SISU FITNESS STAIRS

43	909854	COUNTERSUNK SCREW, M8x50 A4	6
44	910376	BUSHING, Ø30x17	162
45	910416	INSIDE PLUG Ø48/43-45x23	2
46	910455	SUPPORT	1
47	910604	SUPPORT PIECE	4
48	911149	ALLEN SCREW, M10 x 110	87
49	912180	TAPTITE SCREW, M8 x 60, DIN 7500-C, 2 x DELTA	94
50	912500	RIVET, Ø4,8x14	64
51	912515	DIP BAR	1
52	912575	COUNTERSUNK SCREW, M8x110 A4	2
53	914574	FRAME ASSEMBLY	2
54	914579	SUPPORT	8
55	914583	FRAME ASSEMBLY	2
56	914584	FRAME ASSEMBLY	2
57	914585	FRAME ASSEMBLY	2
58	914588	POST	6
59	914590	POST	6
60	914591	FRAME ASSEMBLY	1
61	914592	FRAME ASSEMBLY	1
62	914595	POST	8
63	914596	SUPPORT	6
64	914597	SUPPORT	2
65	914598	SUPPORT	16
66	914601	FRAME ASSEMBLY	1
67	914602	FRAME ASSEMBLY	1
68	914604	SUPPORT	1
69	914605	SUPPORT	1
70	914606	SUPPORT	1
71	914607	SUPPORT	1
72	914608	SUPPORT	1
73	914609	SUPPORT	1
74	914610	SUPPORT	2
75	914611	SUPPORT	1
76	914614	POST	1
77	914635	FRAME ASSEMBLY	1
78	914636	FRAME ASSEMBLY	1
79	914637	FRAME ASSEMBLY	1
80	914638	FRAME ASSEMBLY	1
81	914651	HANDRAIL	1
82	914654	HANDRAIL	1
83	914700	HANDRAIL	3
84	914705	HANDRAIL	1
85	914711	HANDRAIL	1
86	914720	HANDRAIL	24
87	914735	GRID	8
88	914736	GRID	1
89	914737	GRID	1

SISU FITNESS STAIRS

90	914743	TUBE ASSEMBLY	2
91	914746	BAR ELEMENT	4
92	914747	BAR ELEMENT	11
93	914751	TUBE ASSEMBLY	30
94	914753	BRACKET	45
95	914777	STEP	30
96	914797	STEP	7
97	914819	T-33 NORMAL FASTENER	94
98	914835	SUPPORT	14
99	914885	ALLEN SCREW, M10 x 60	72
100	914904	COUNTERSUNK SCREW, M8x25 A2	62
101	915360	COVER	5
102	915361	COVER	1
103	915409	SUPPORT	2
104	915416	COUNTER	1
105	915450	HANDRAIL	1
106	980151	WASHER, (M8), DIN 125, HDG	70
107	980154	WASHER, (M12), DIN 125, HDG	666
108	914838-213	SIGN, YELLOW	15
109	914838-241	SIGN, BLUE	15
110	914838-260	SIGN, RED	15
111	M99452	ALLEN SCREW, M10x30	4

SISU FITNESS STAIRS

STAIRS (2 PCS)

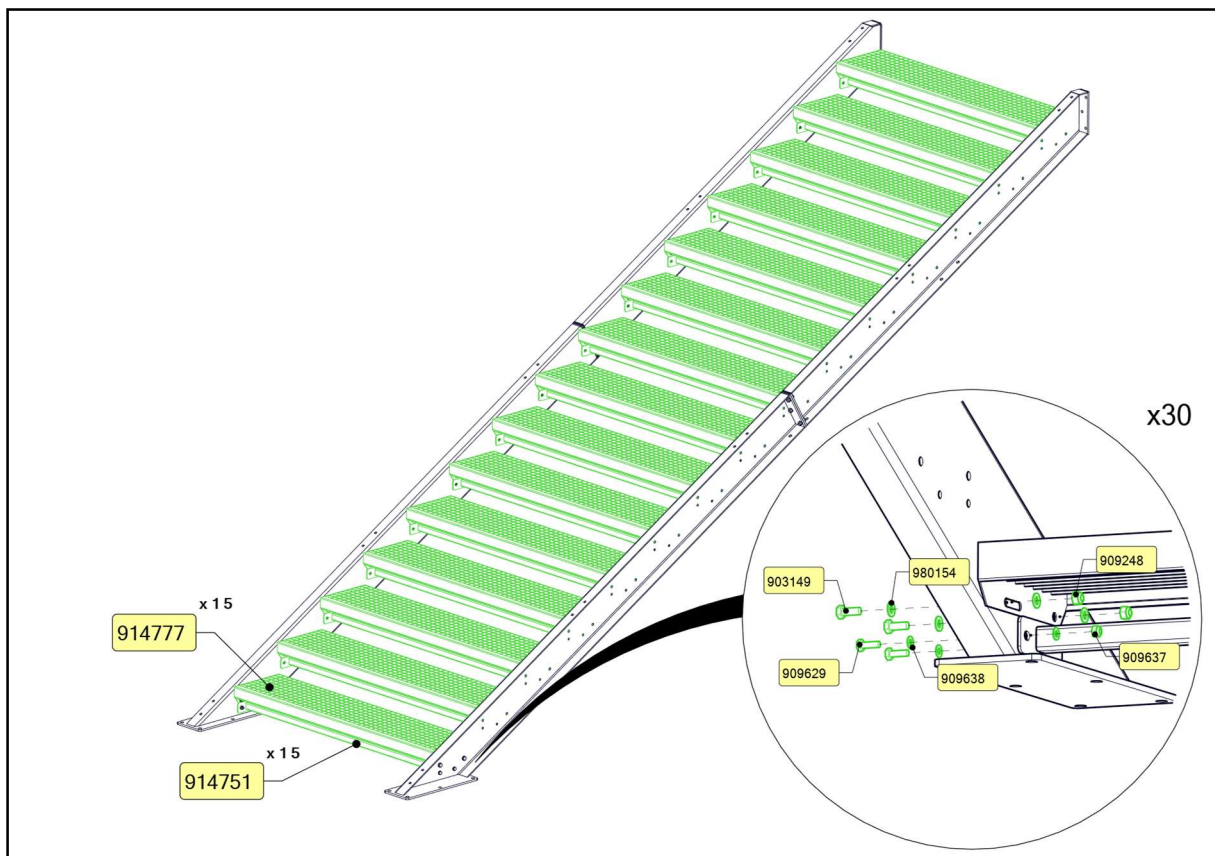
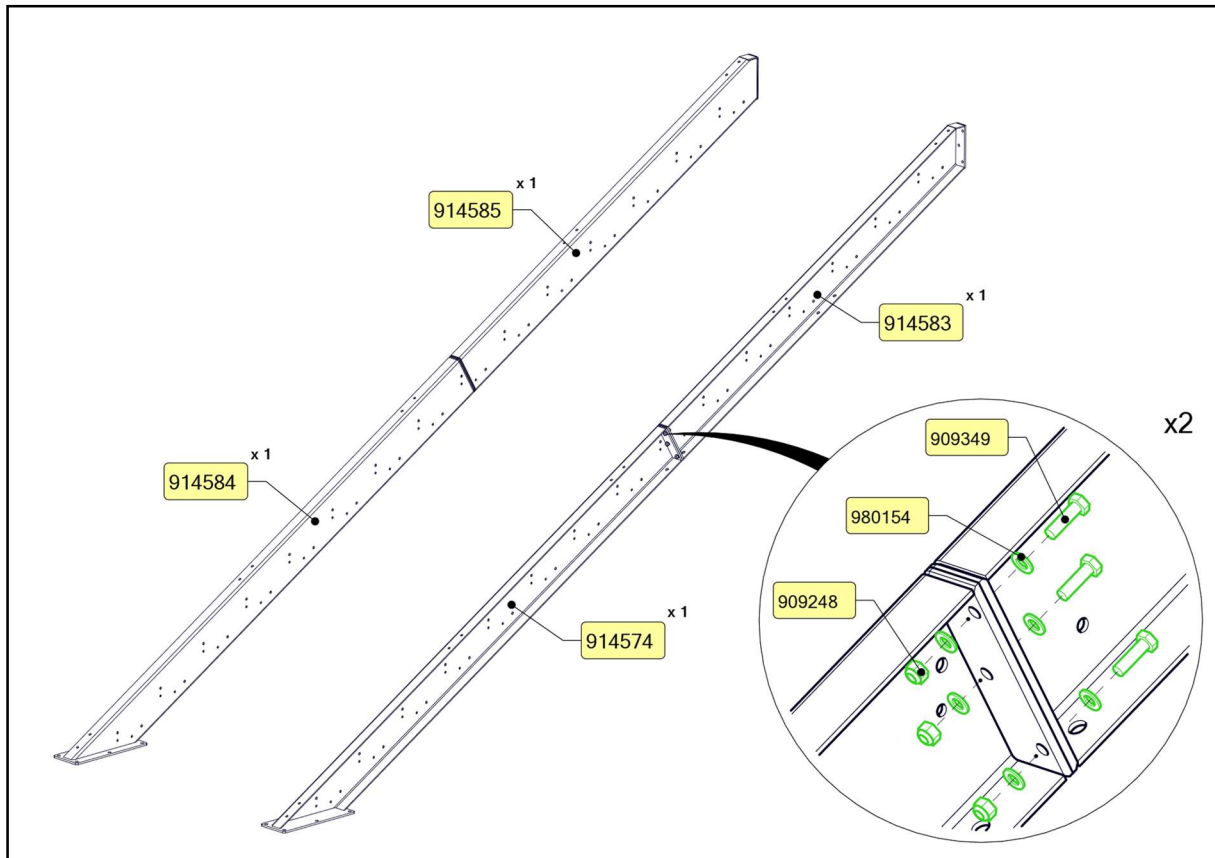

SISU FITNESS STAIRS

STAIRS (2 PCS)

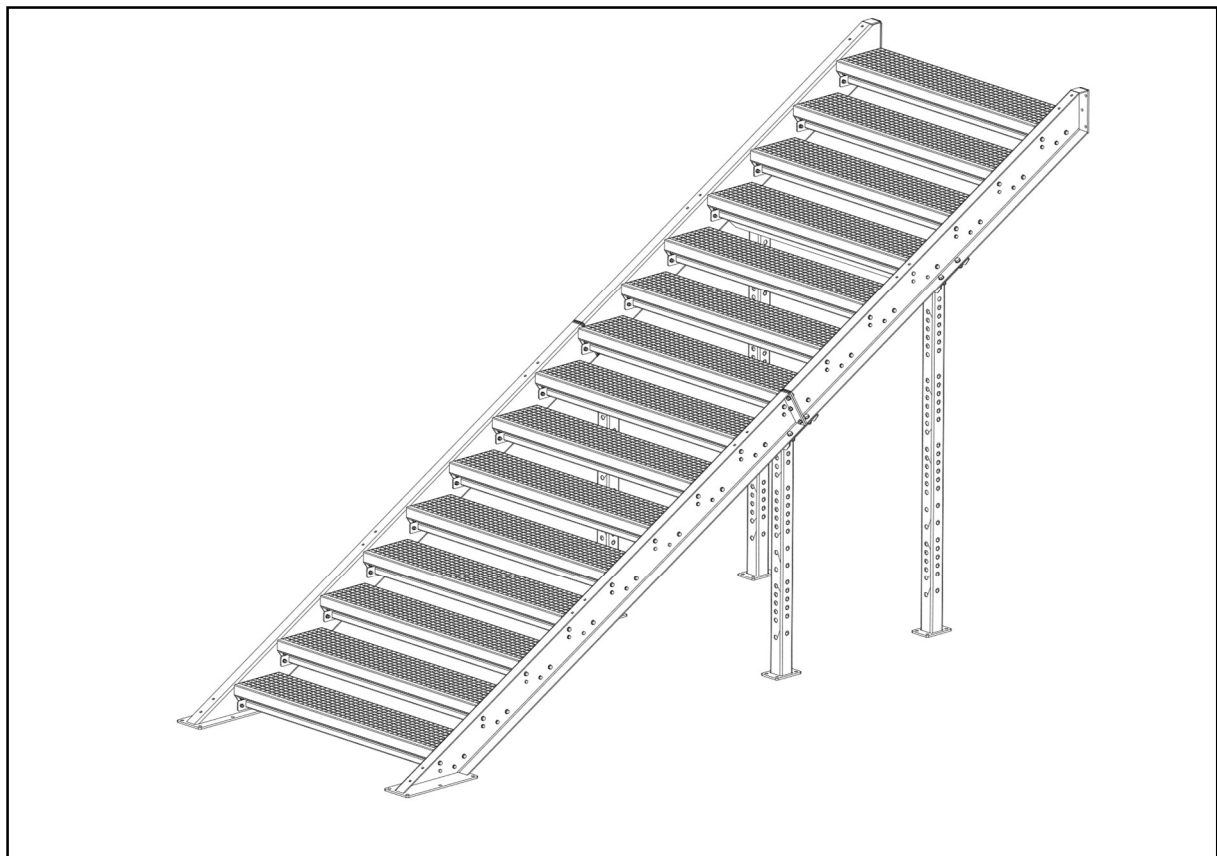
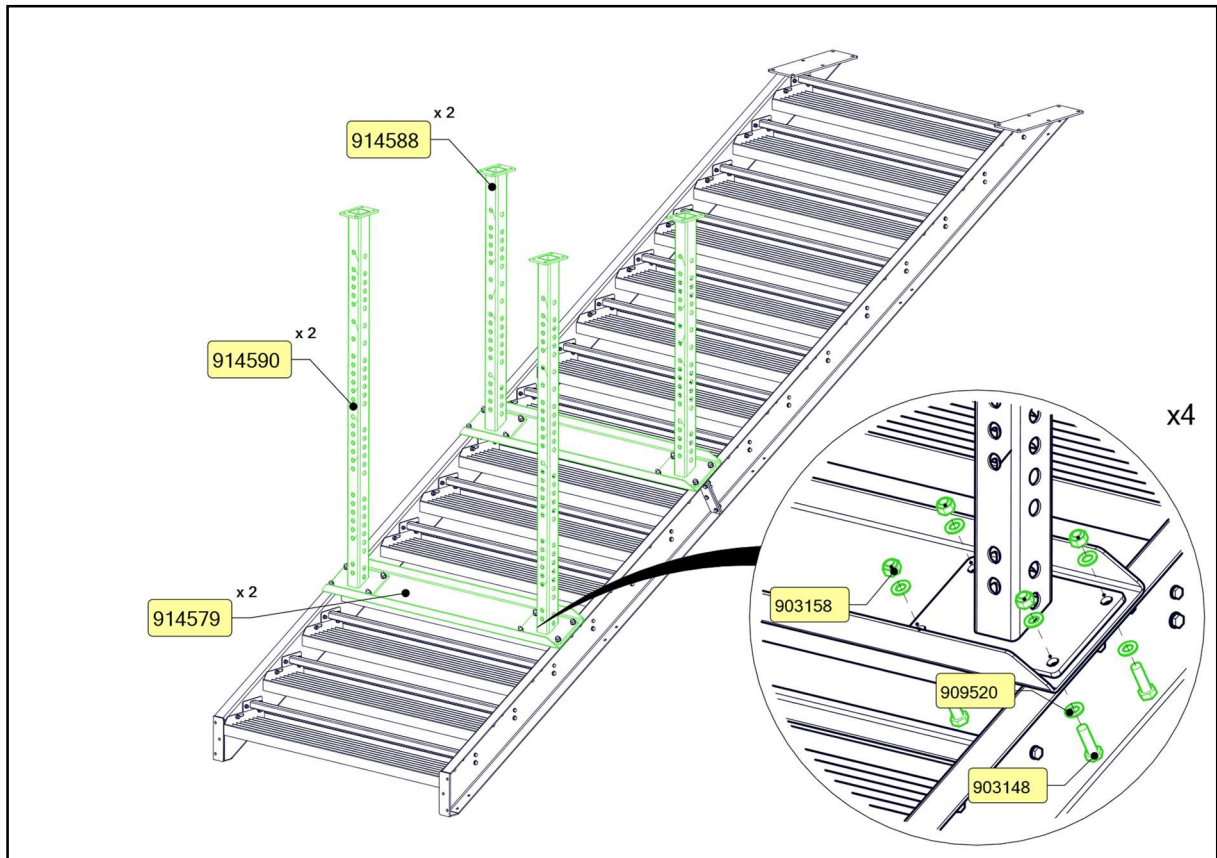

SISU FITNESS STAIRS

RAMP (1 PC)

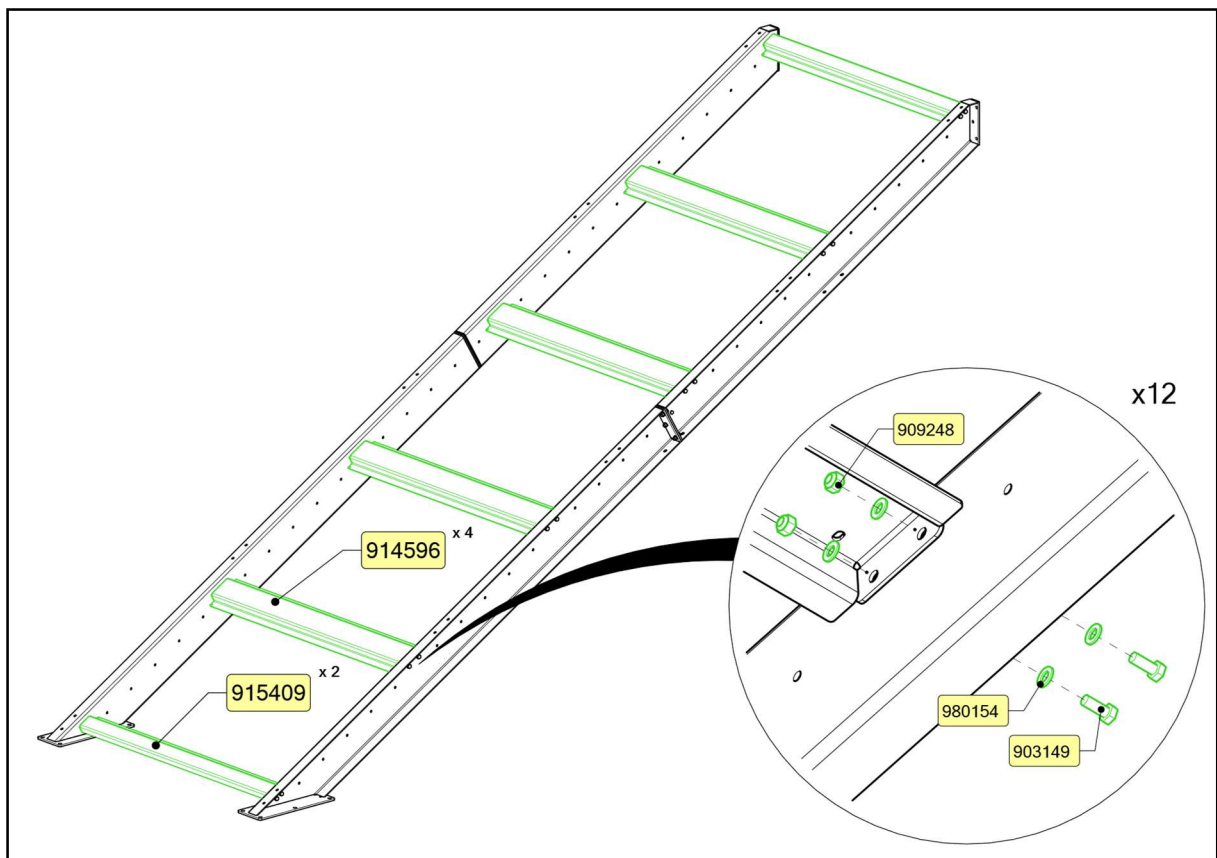
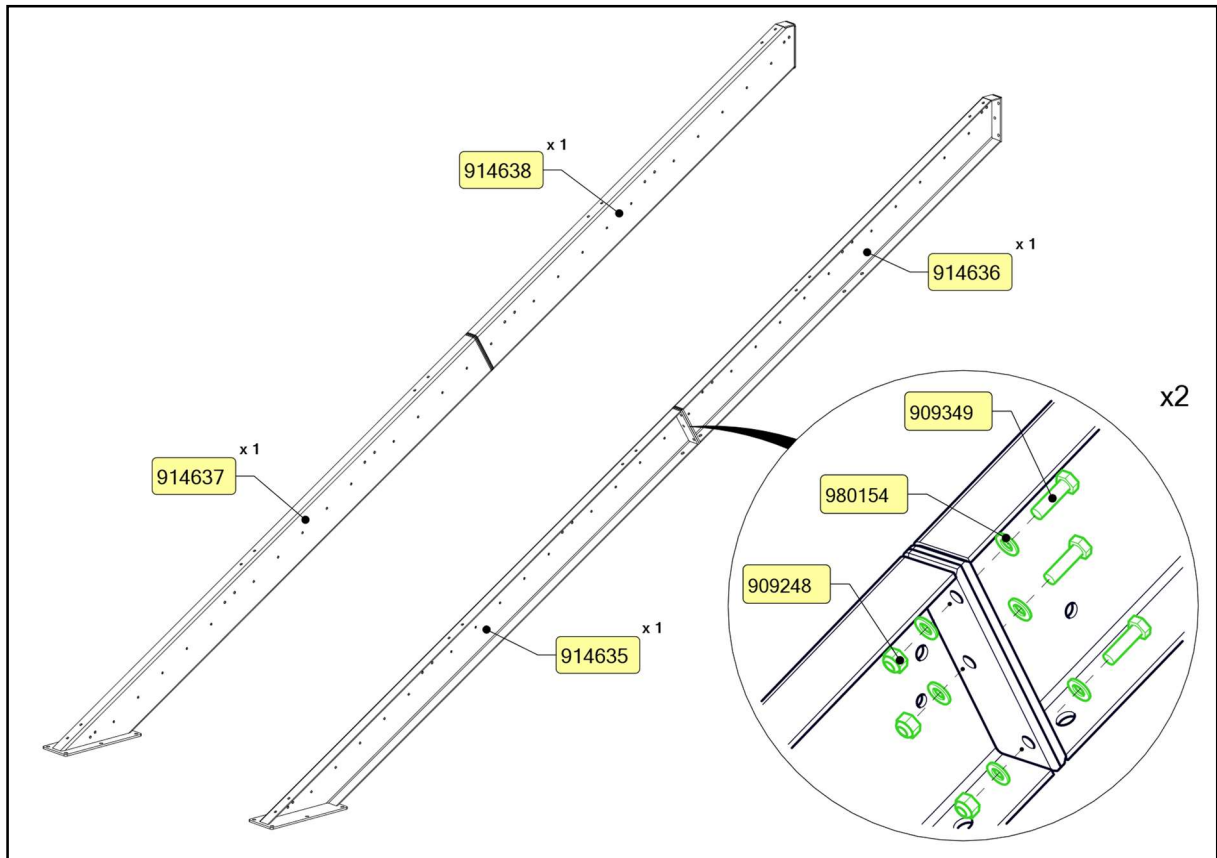

SISU FITNESS STAIRS

RAMP (1 PC)

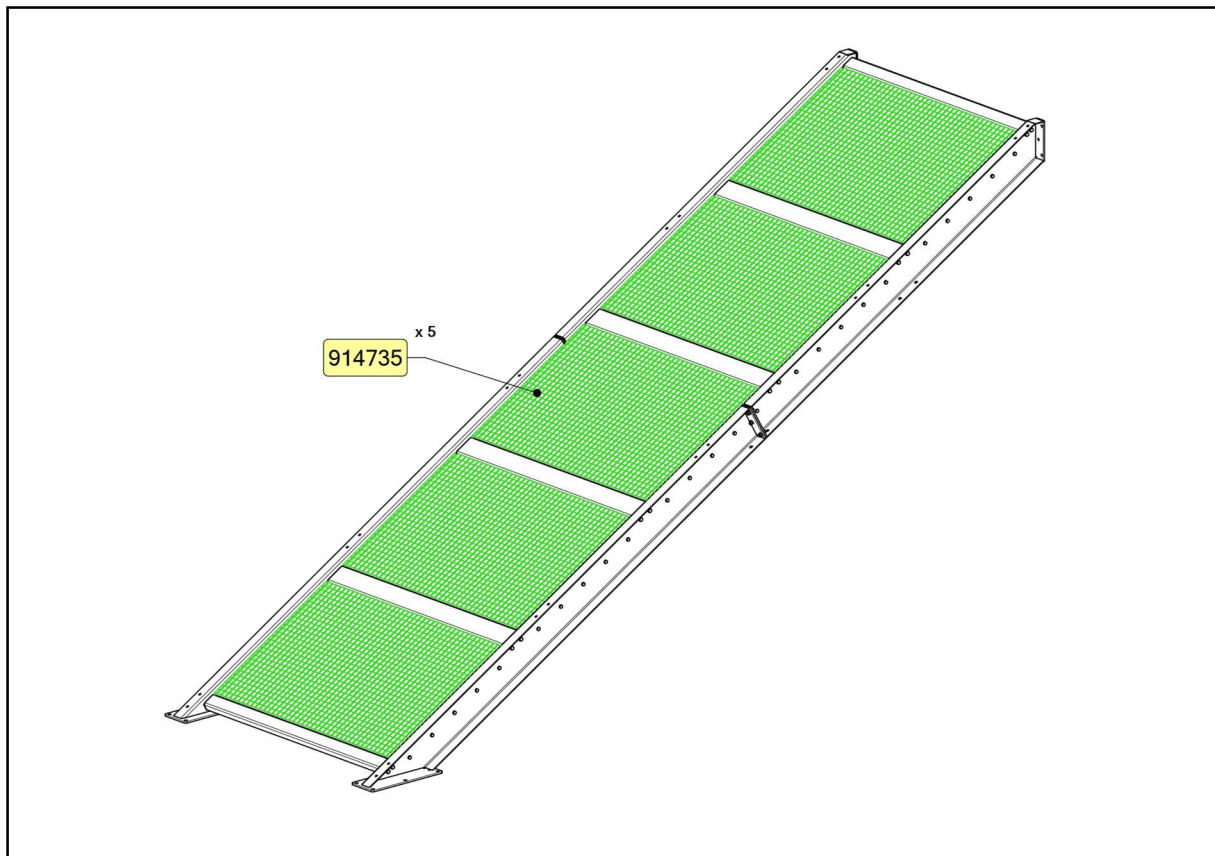
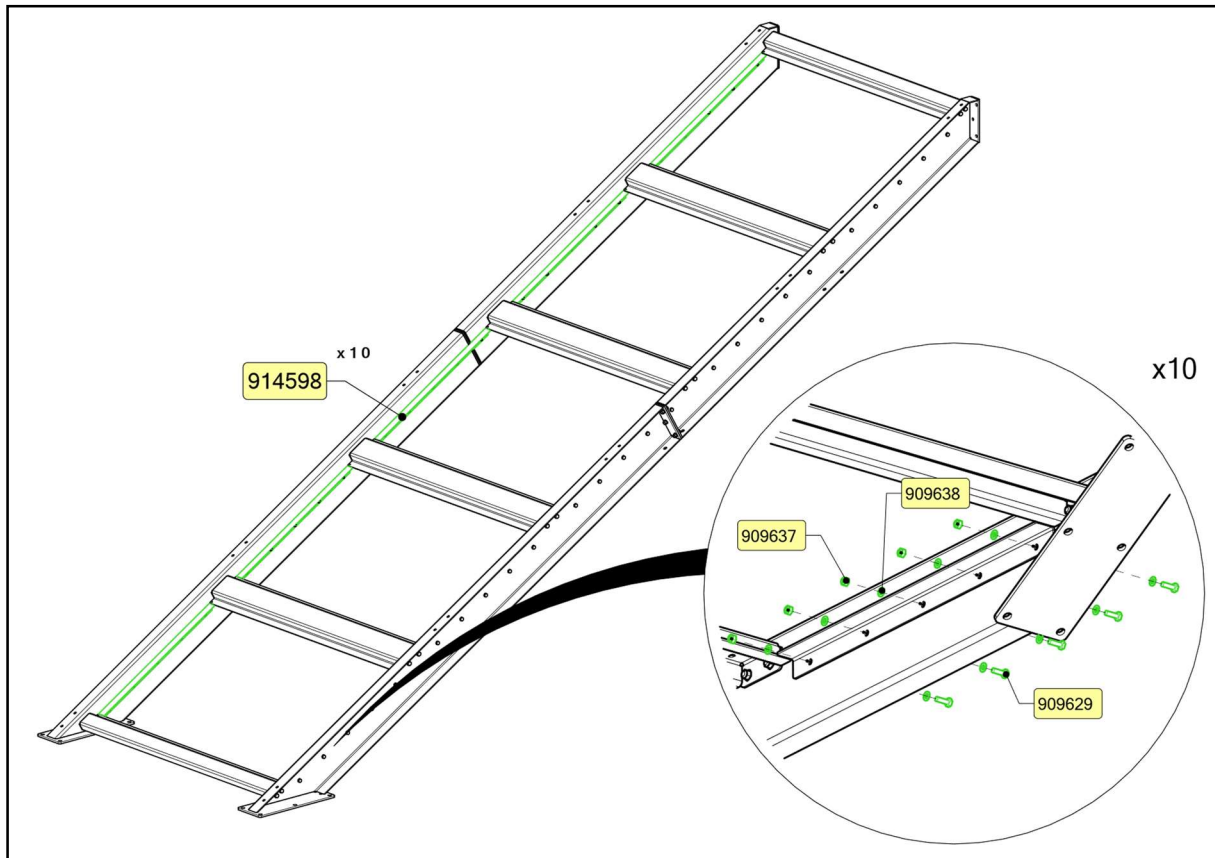

SISU FITNESS STAIRS

RAMP (1 PC)

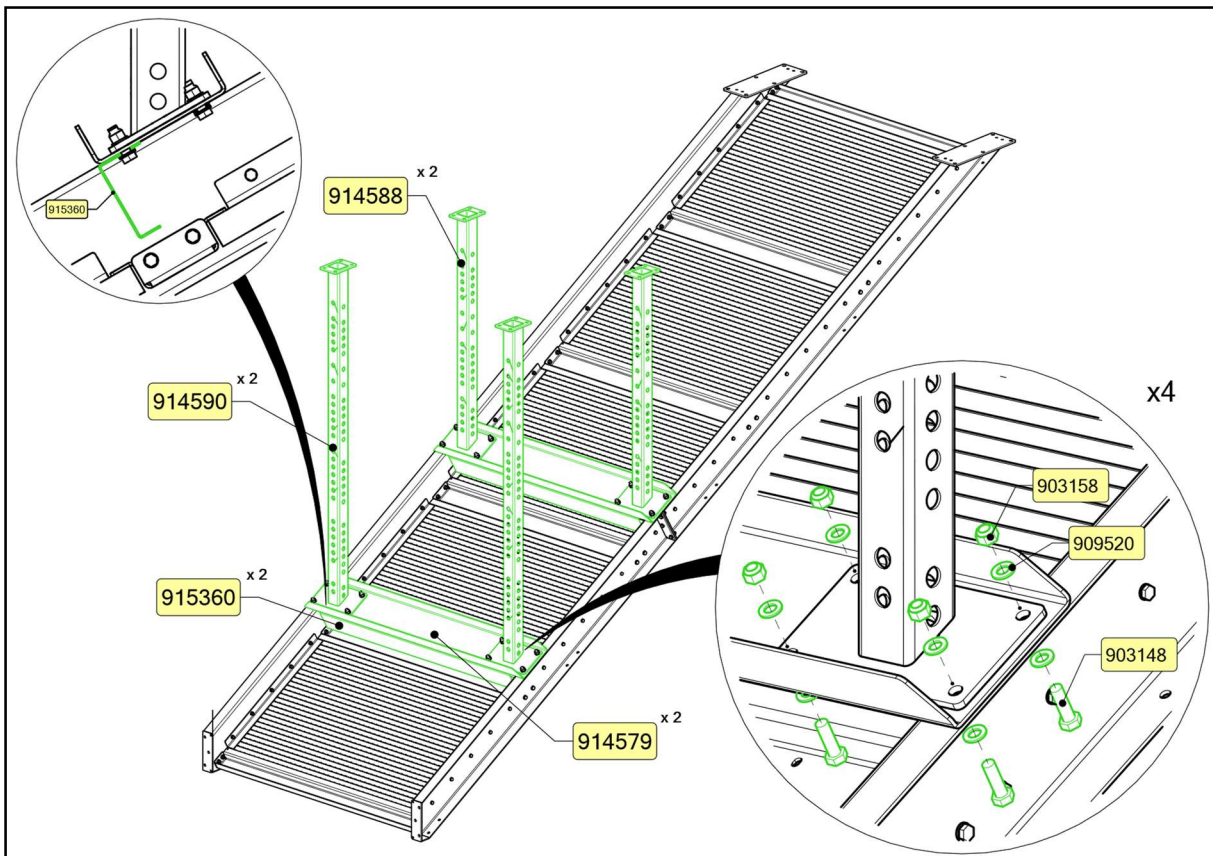
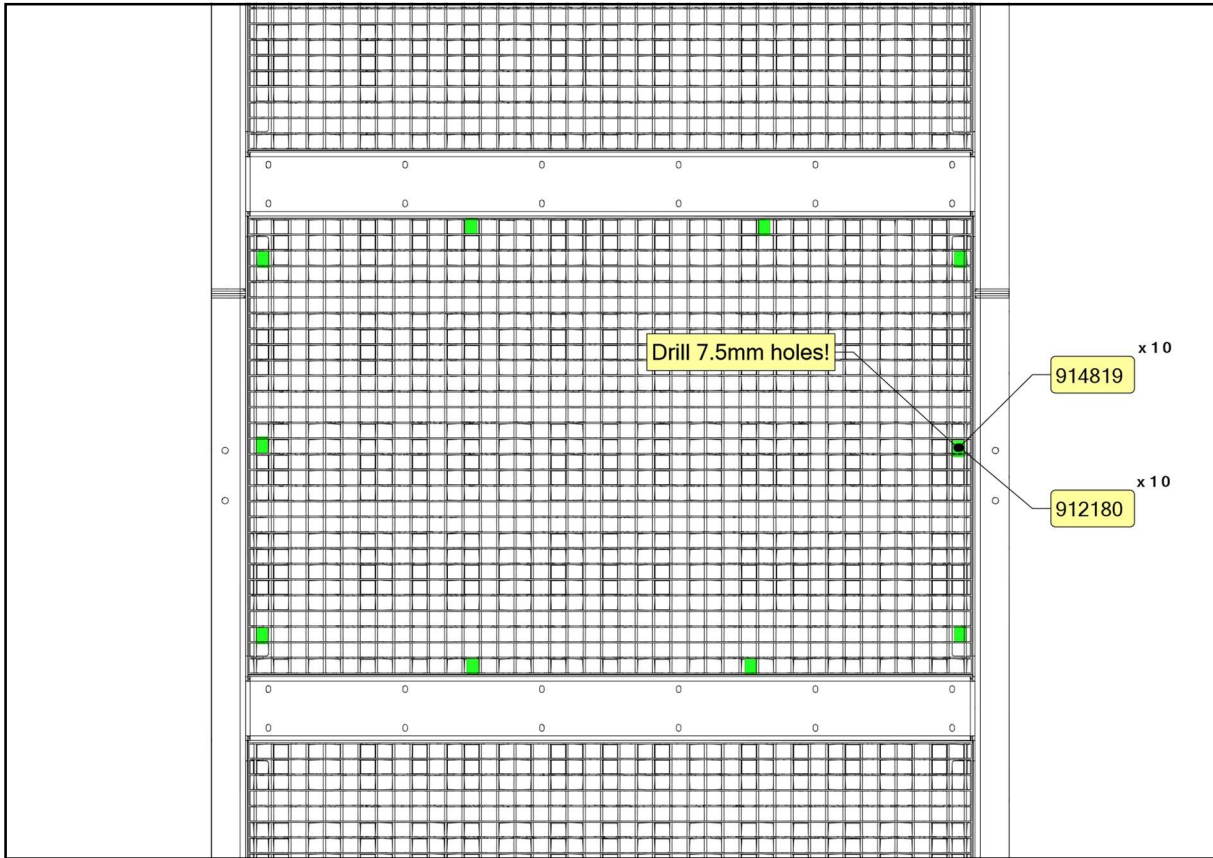

SISU FITNESS STAIRS

RAMP (1 PC)

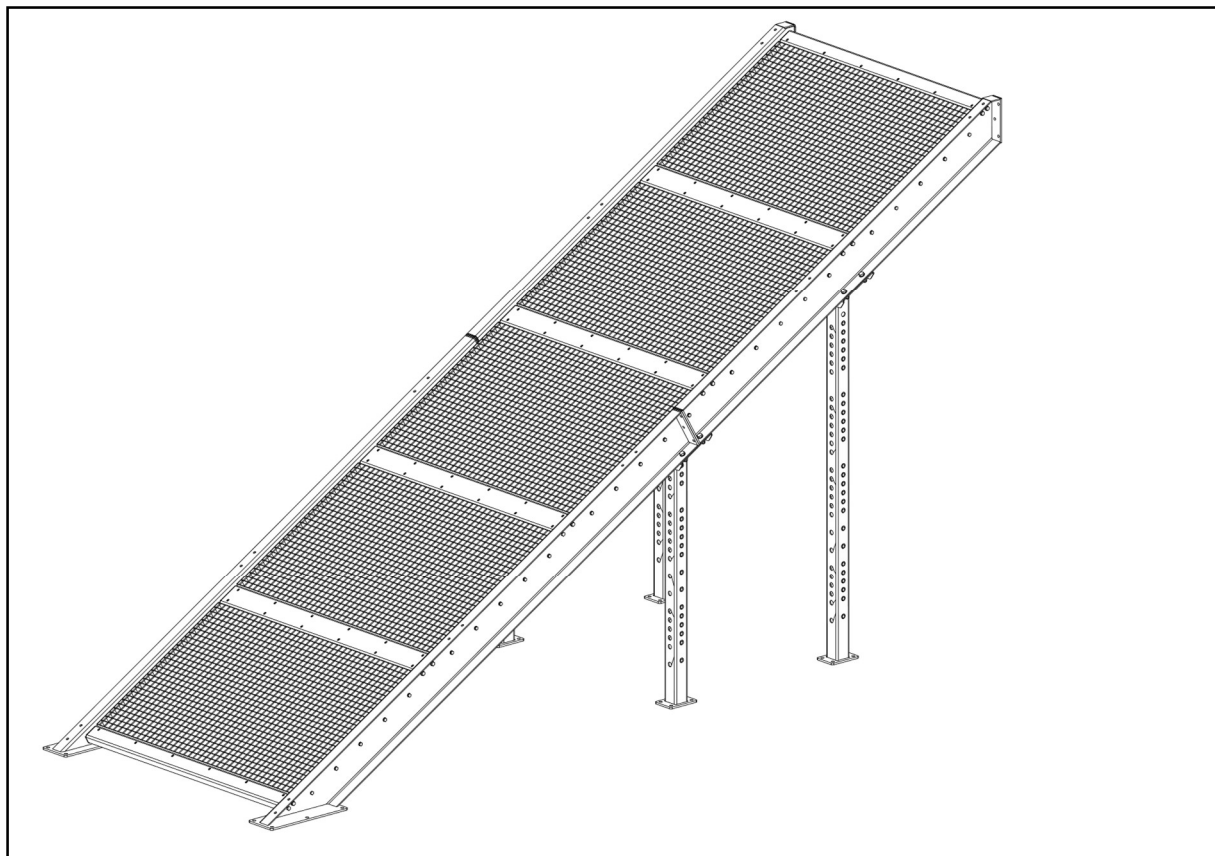
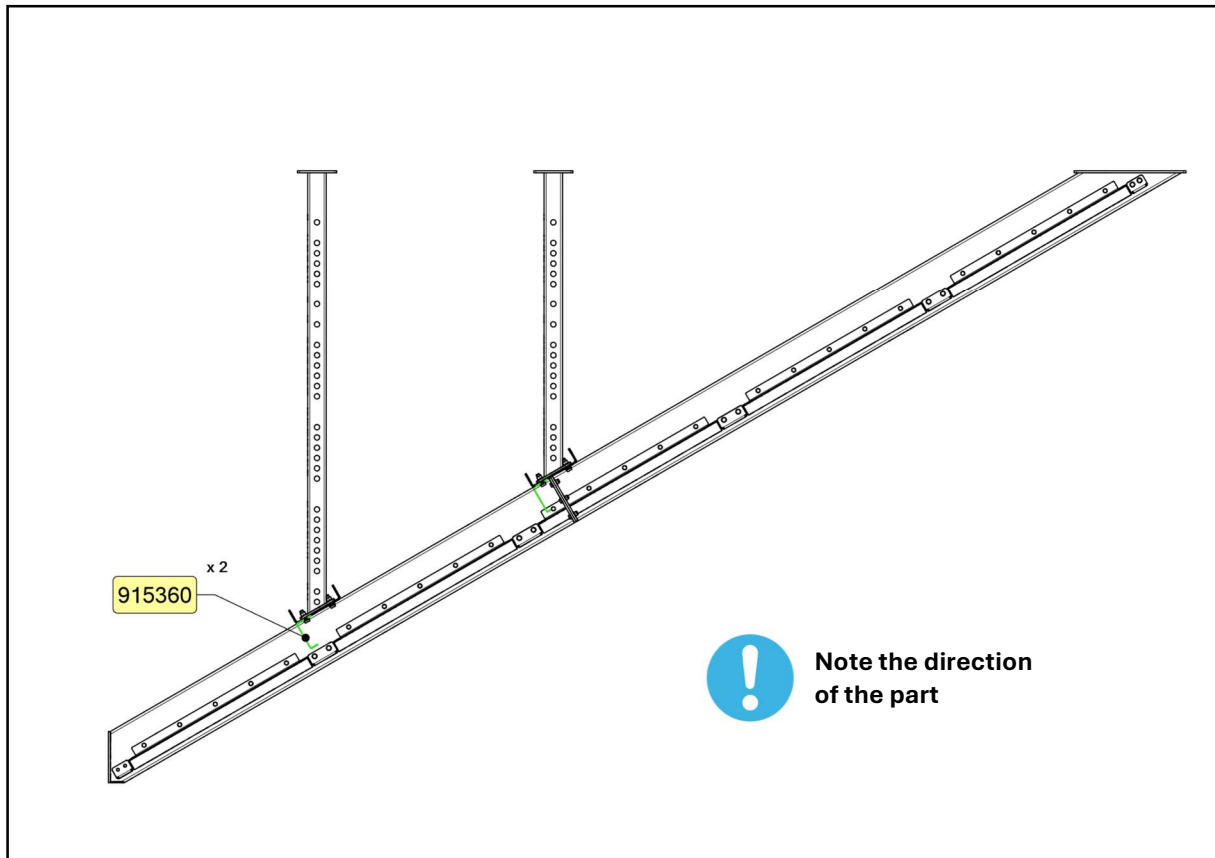

SISU FITNESS STAIRS

FLOOR-1 (1 PC)

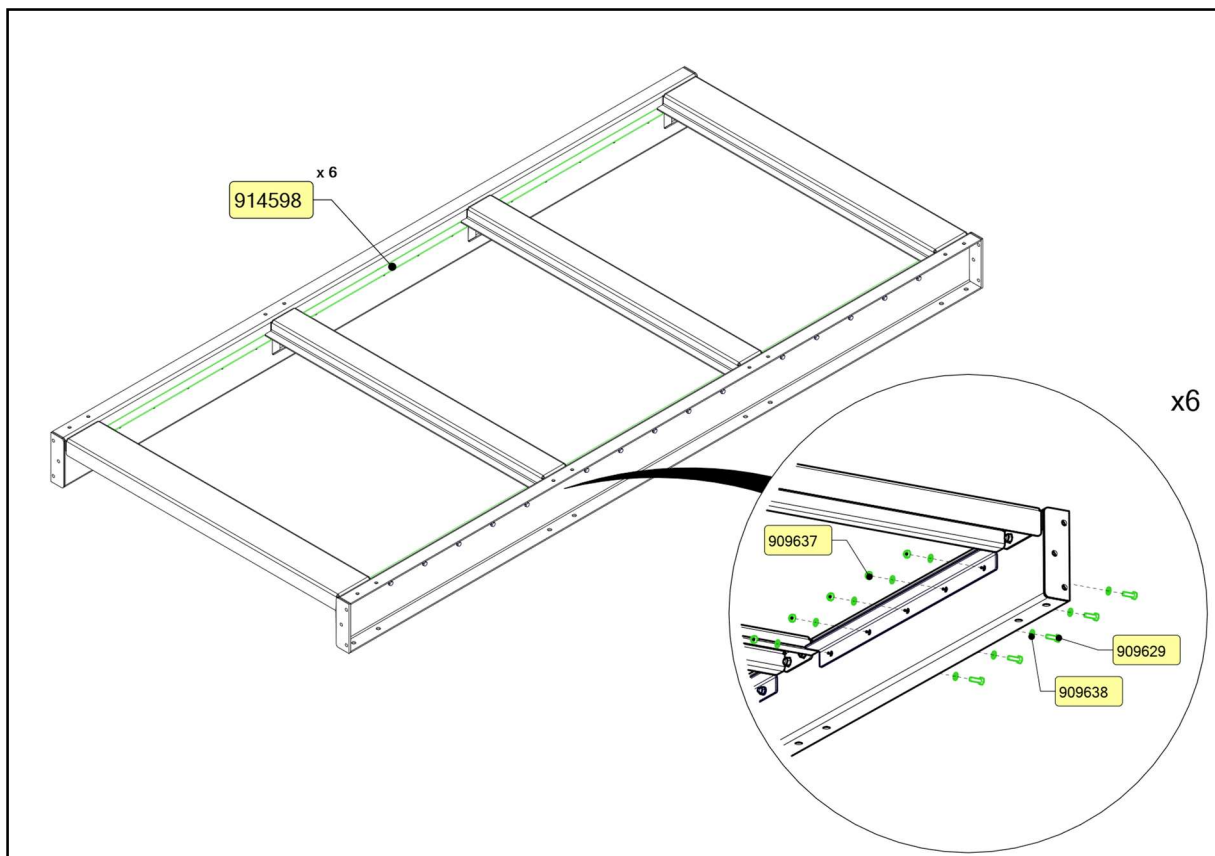
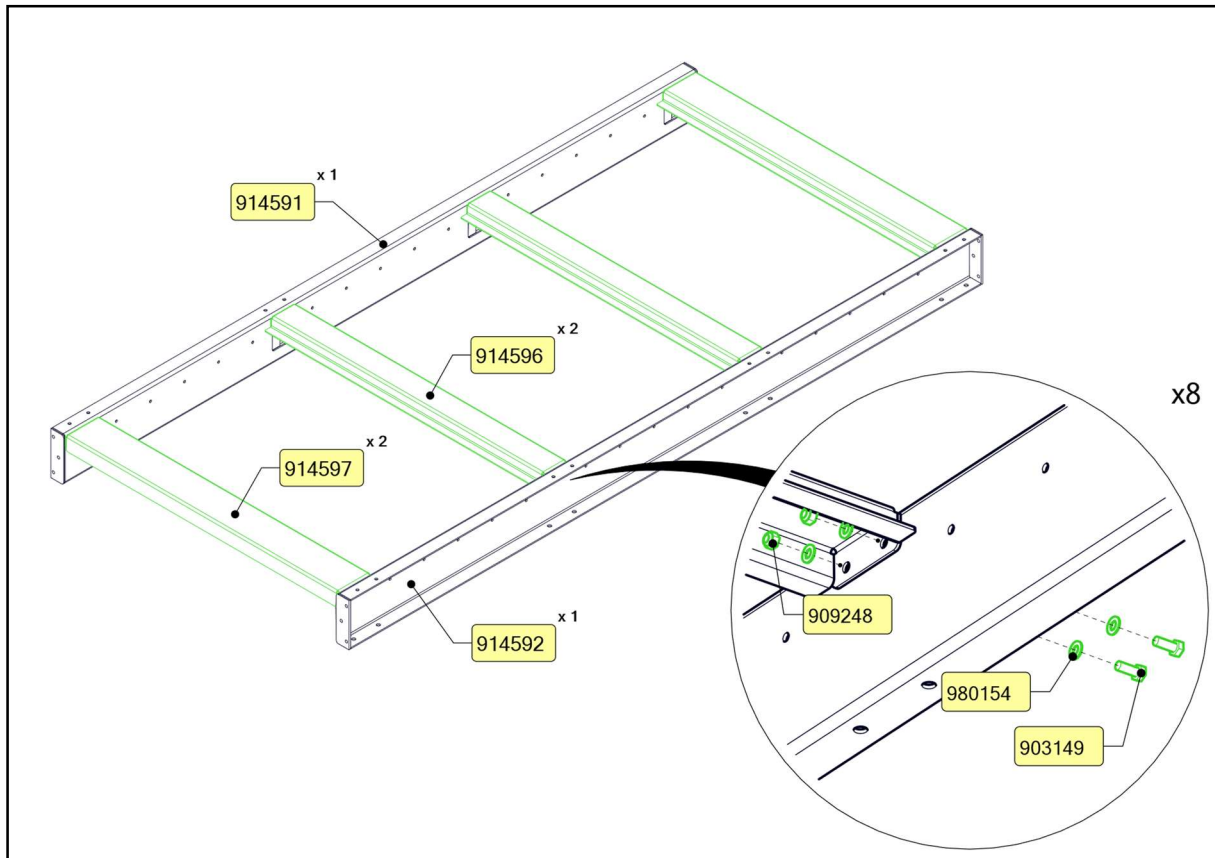

SISU FITNESS STAIRS

FLOOR-1 (1 PC)

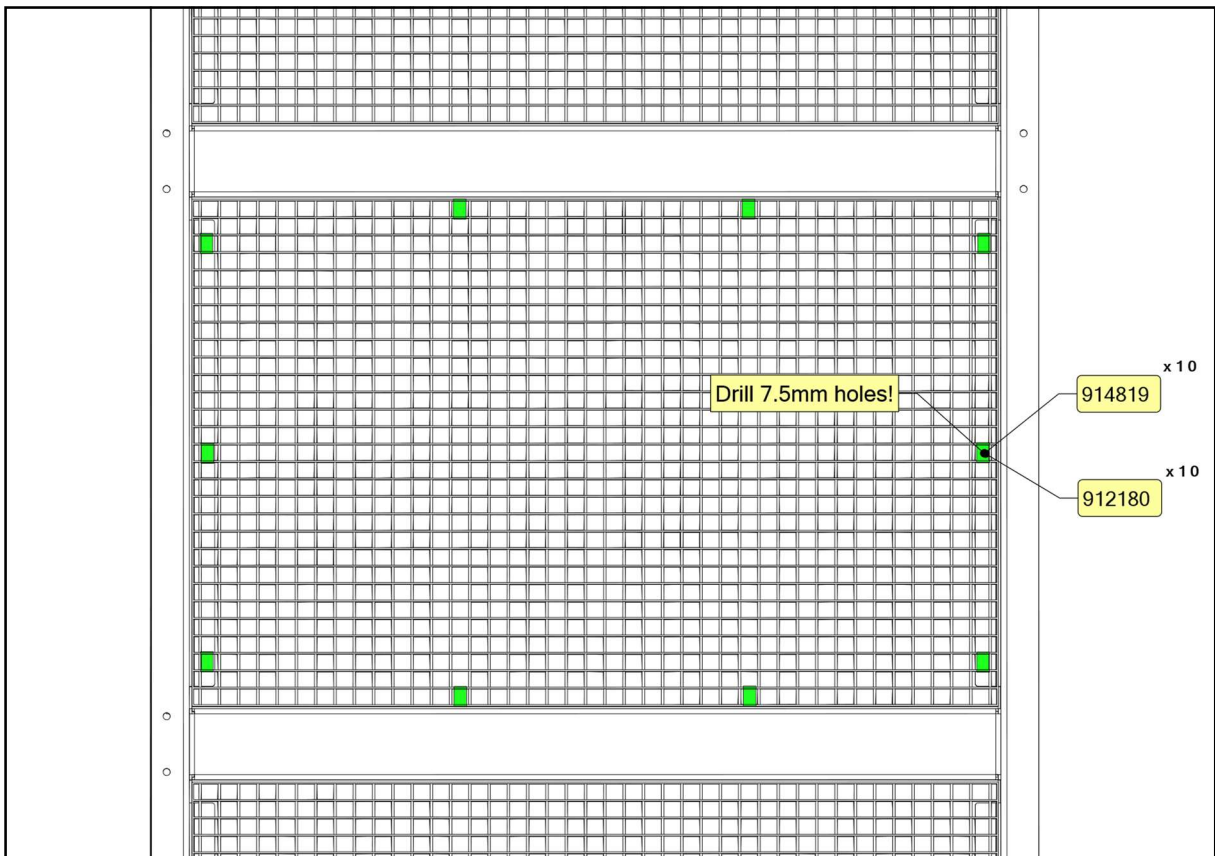
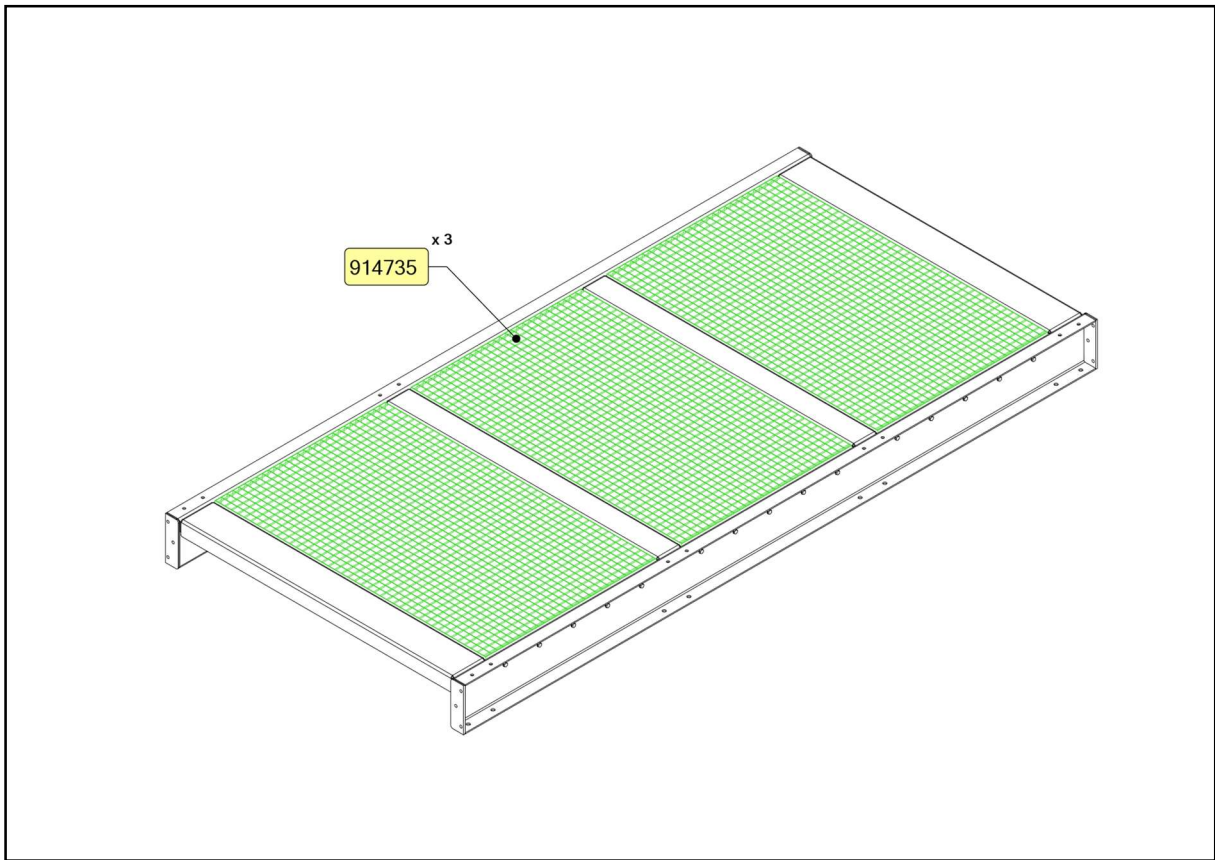

SISU FITNESS STAIRS

FLOOR-1 (1 PC)

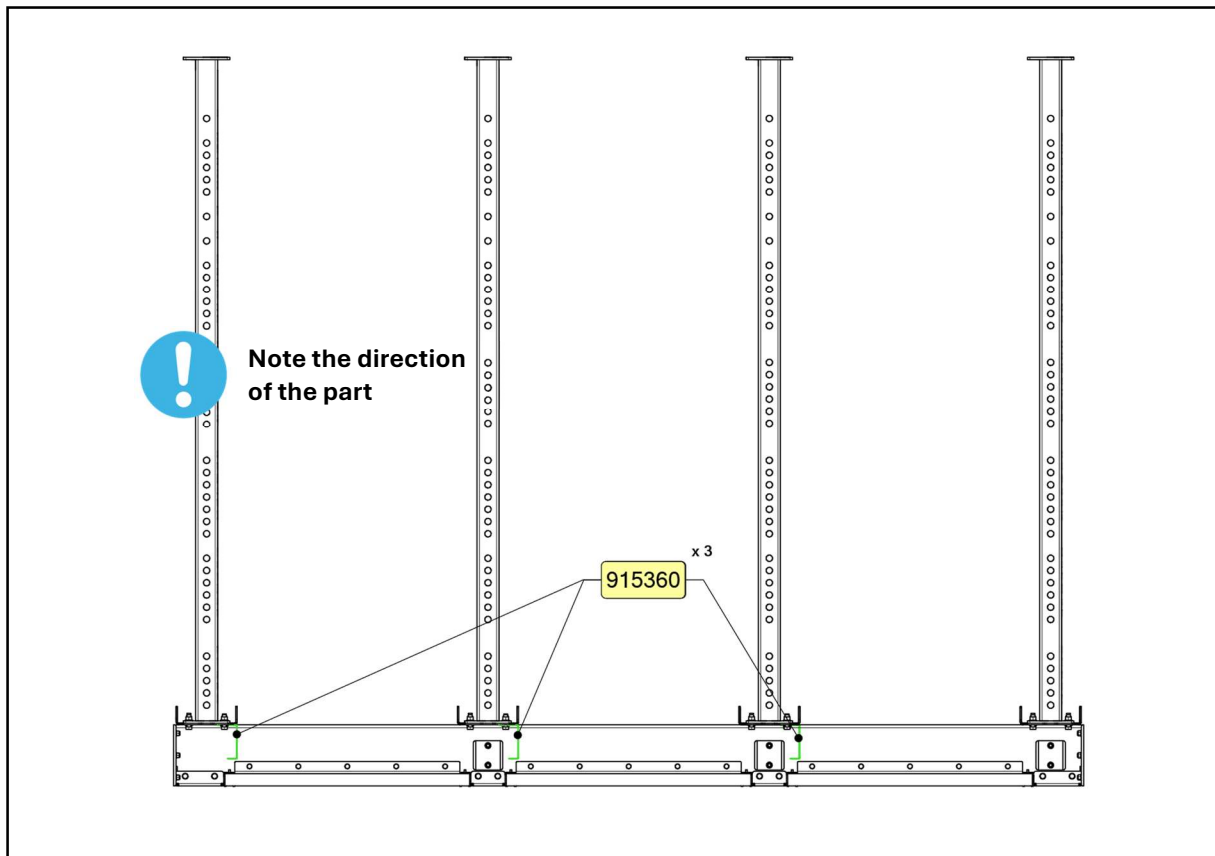
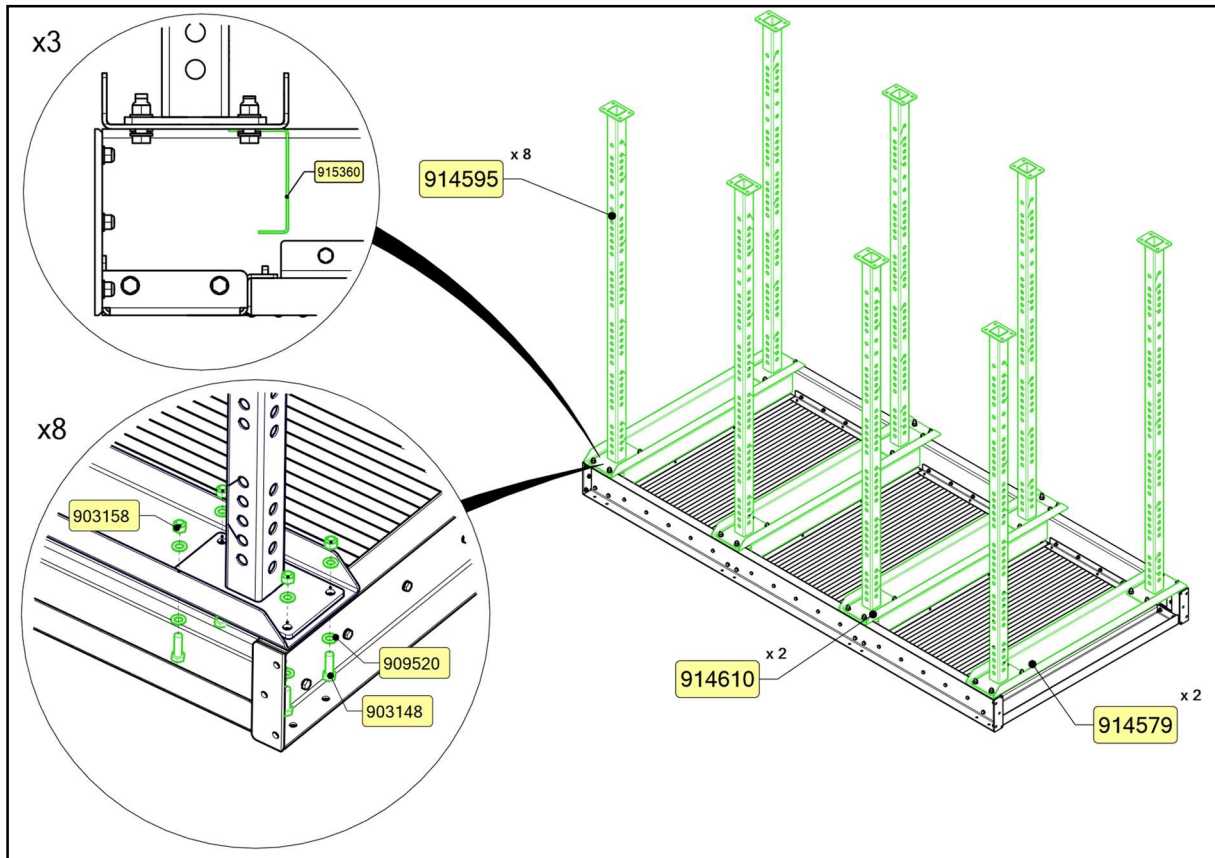

SISU FITNESS STAIRS

FLOOR-1 (1 PC)

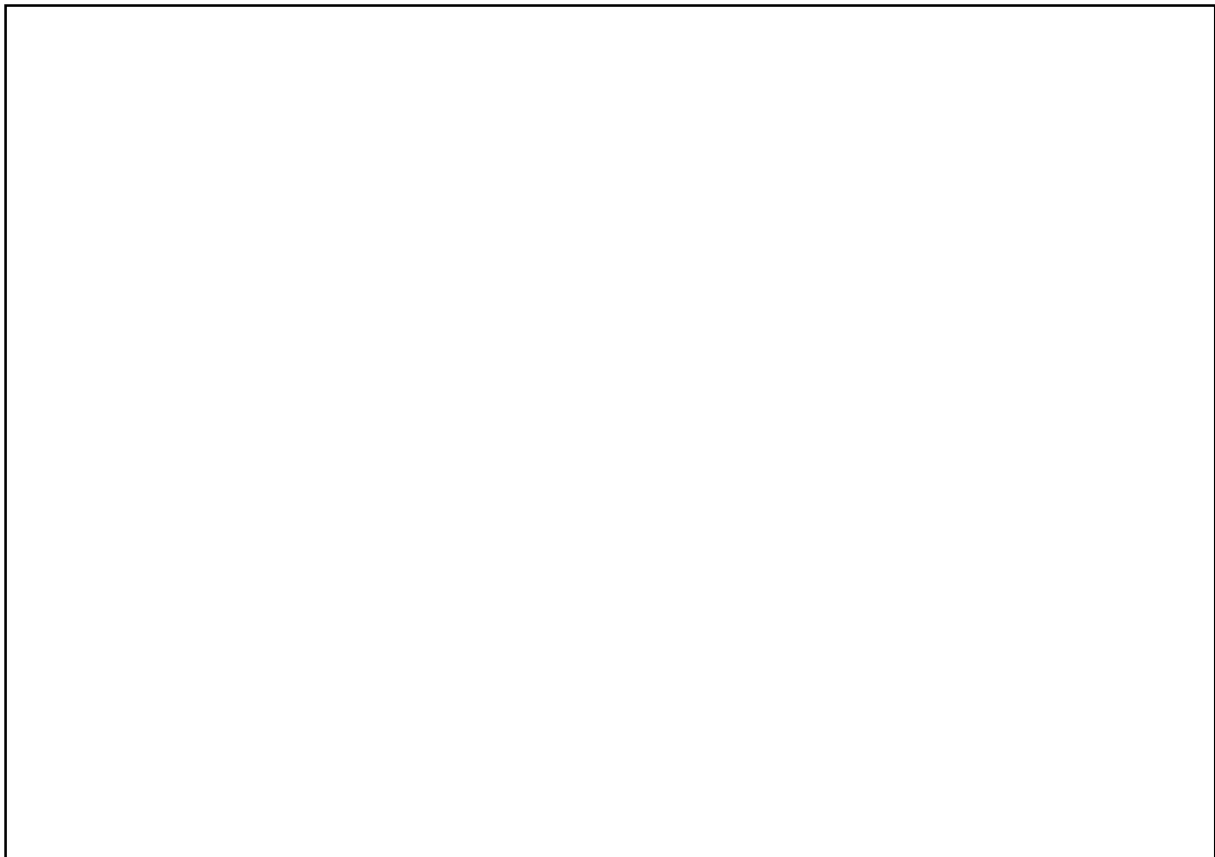
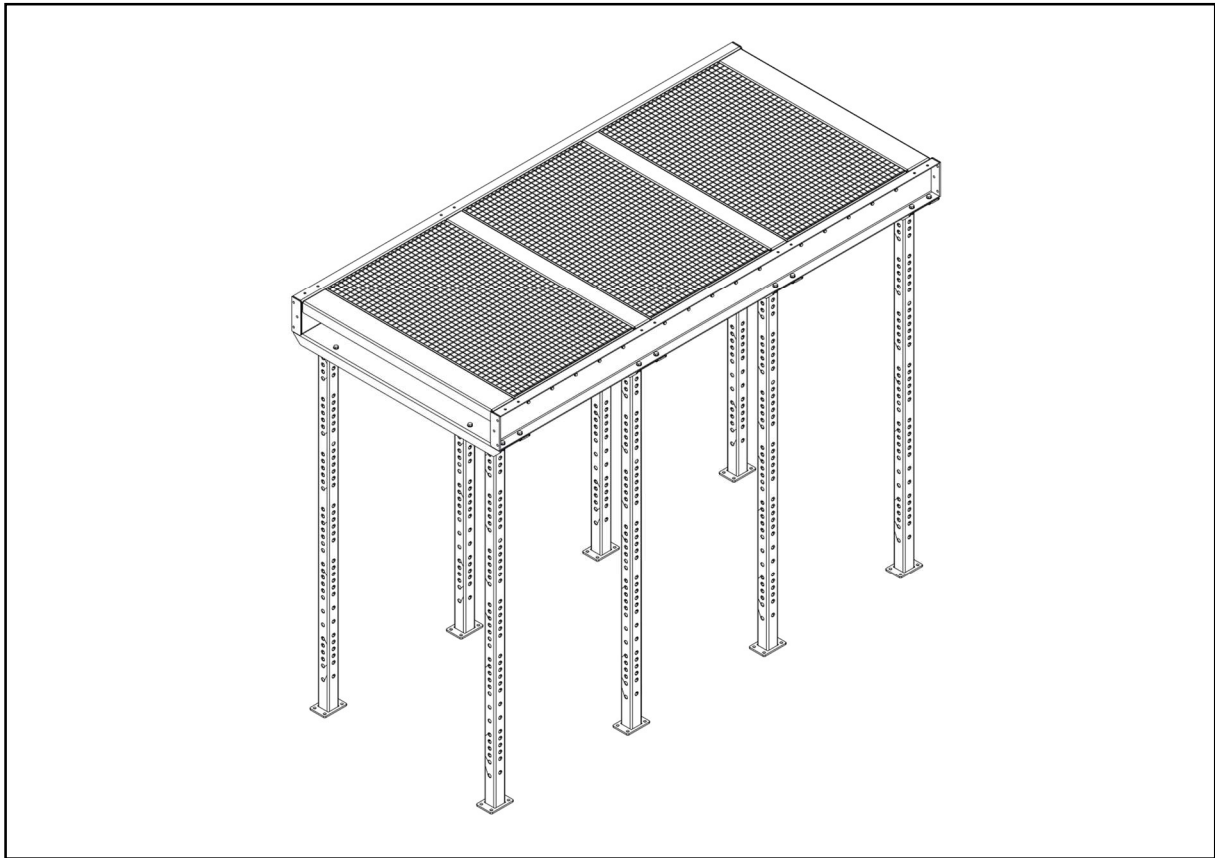

SISU FITNESS STAIRS

FLOOR-2 (1 PC)

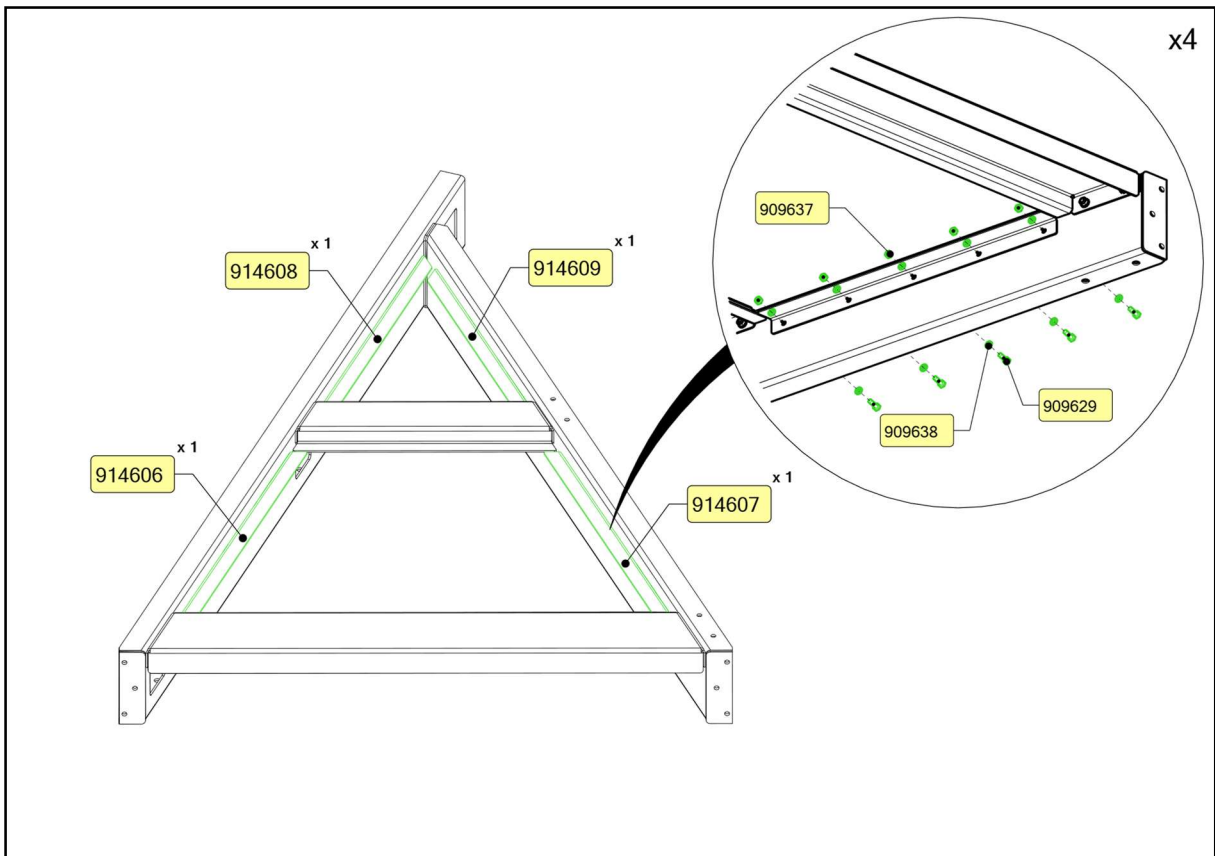
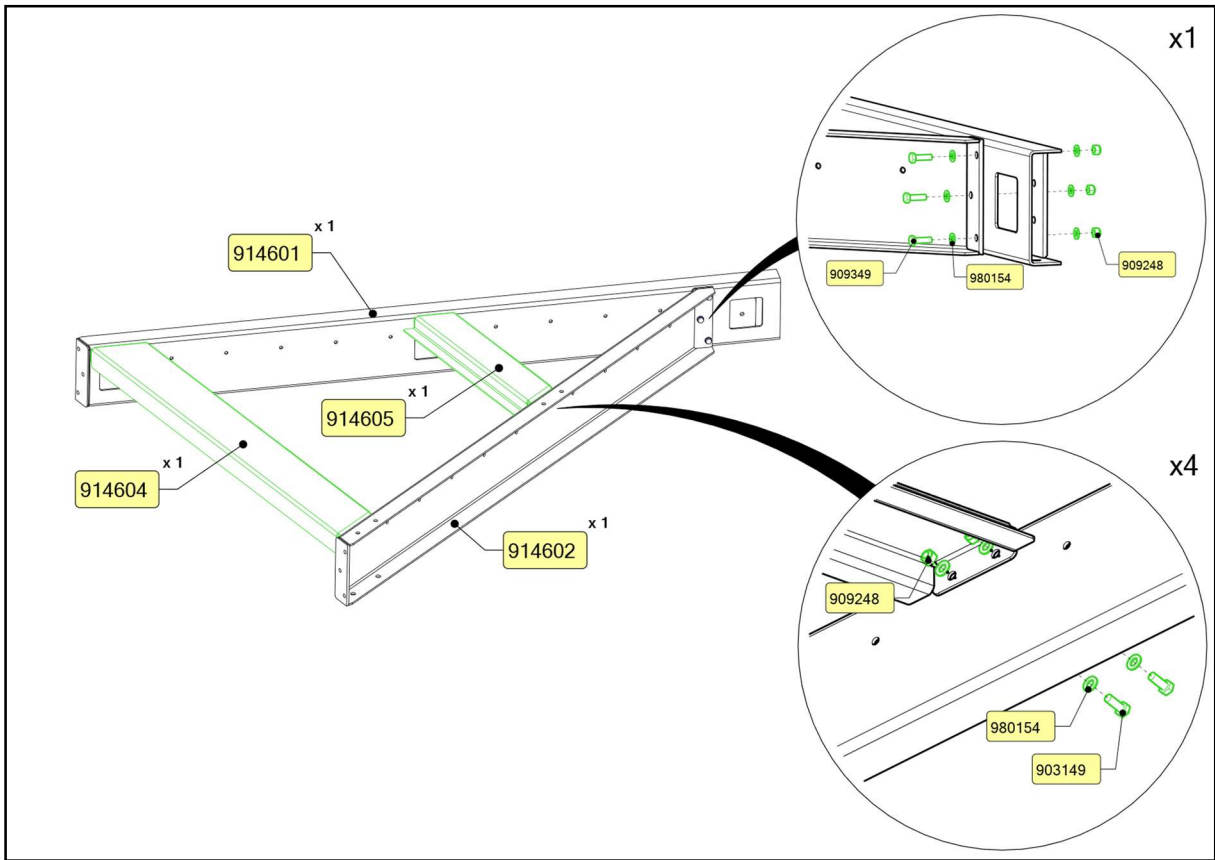

SISU FITNESS STAIRS

FLOOR-2 (1 PC)

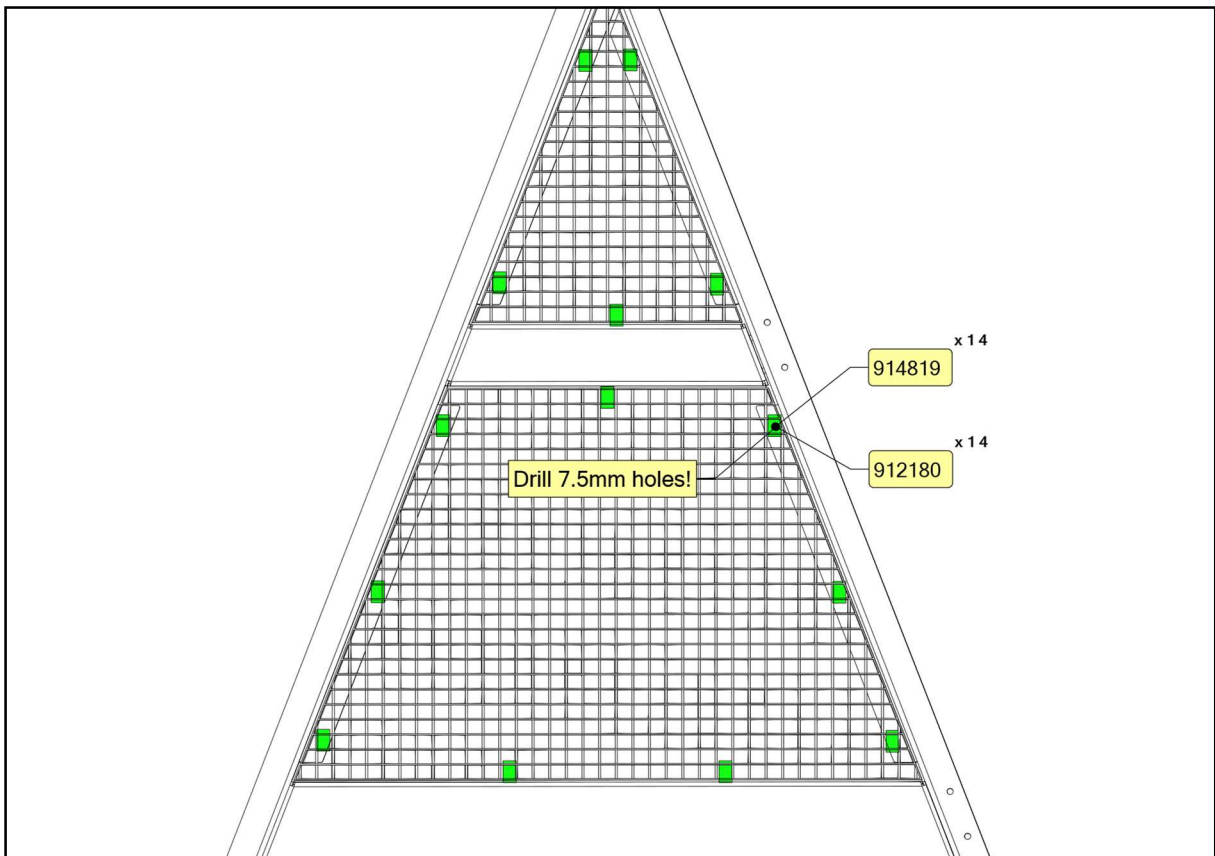
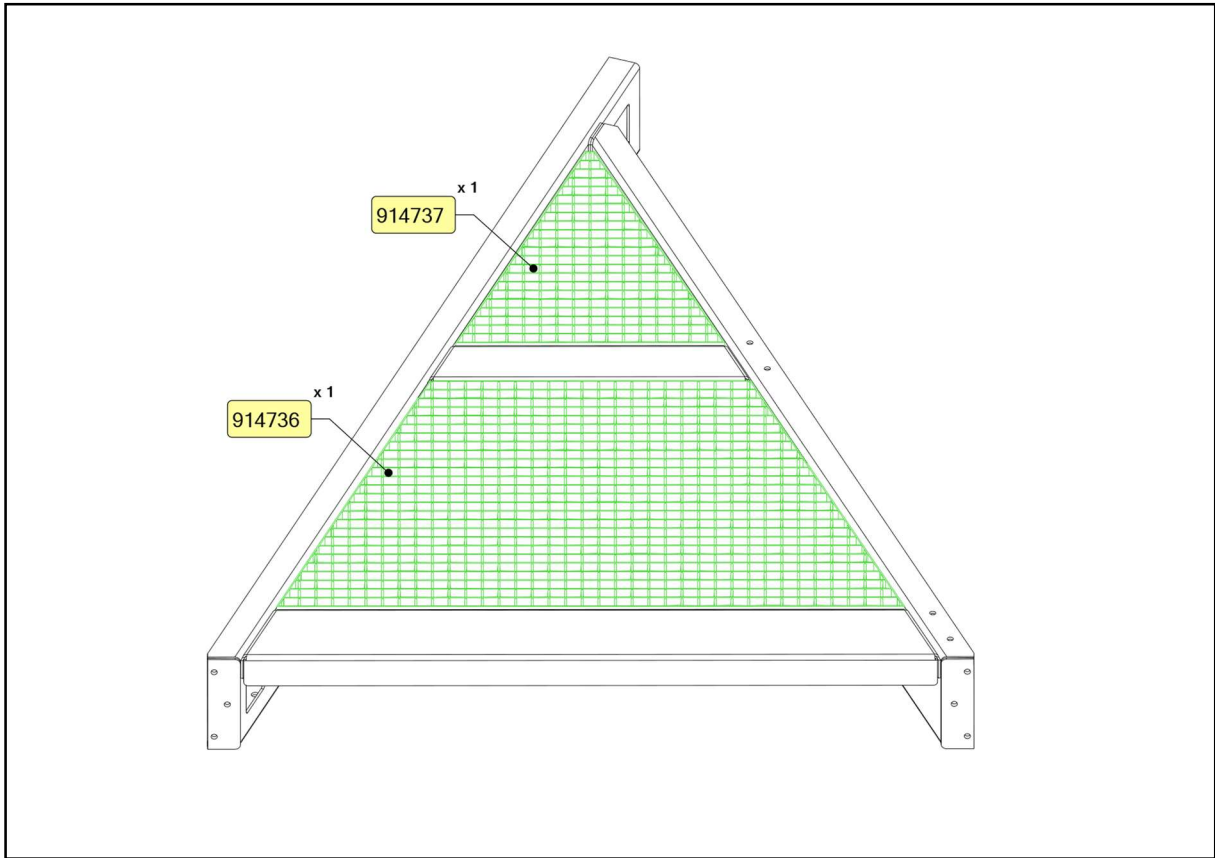

SISU FITNESS STAIRS

FLOOR-2 (1 PC)

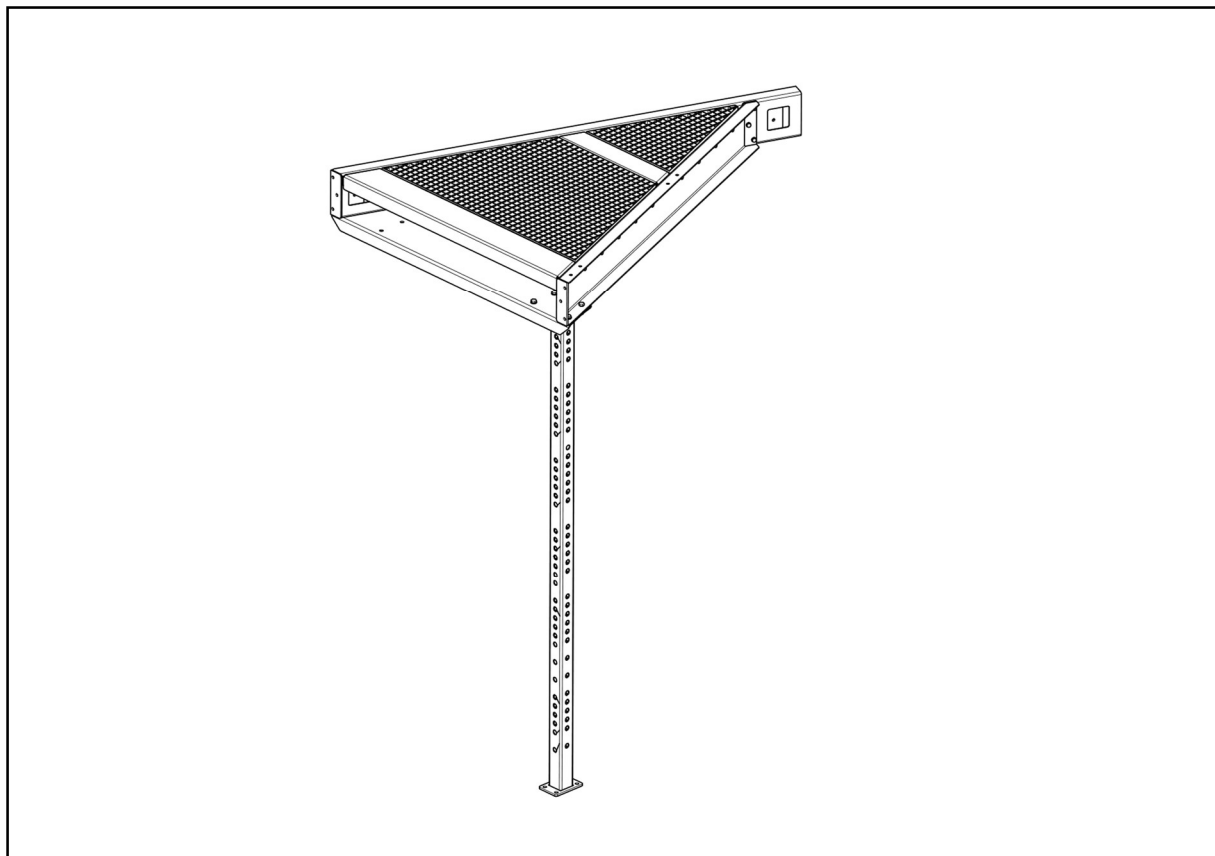
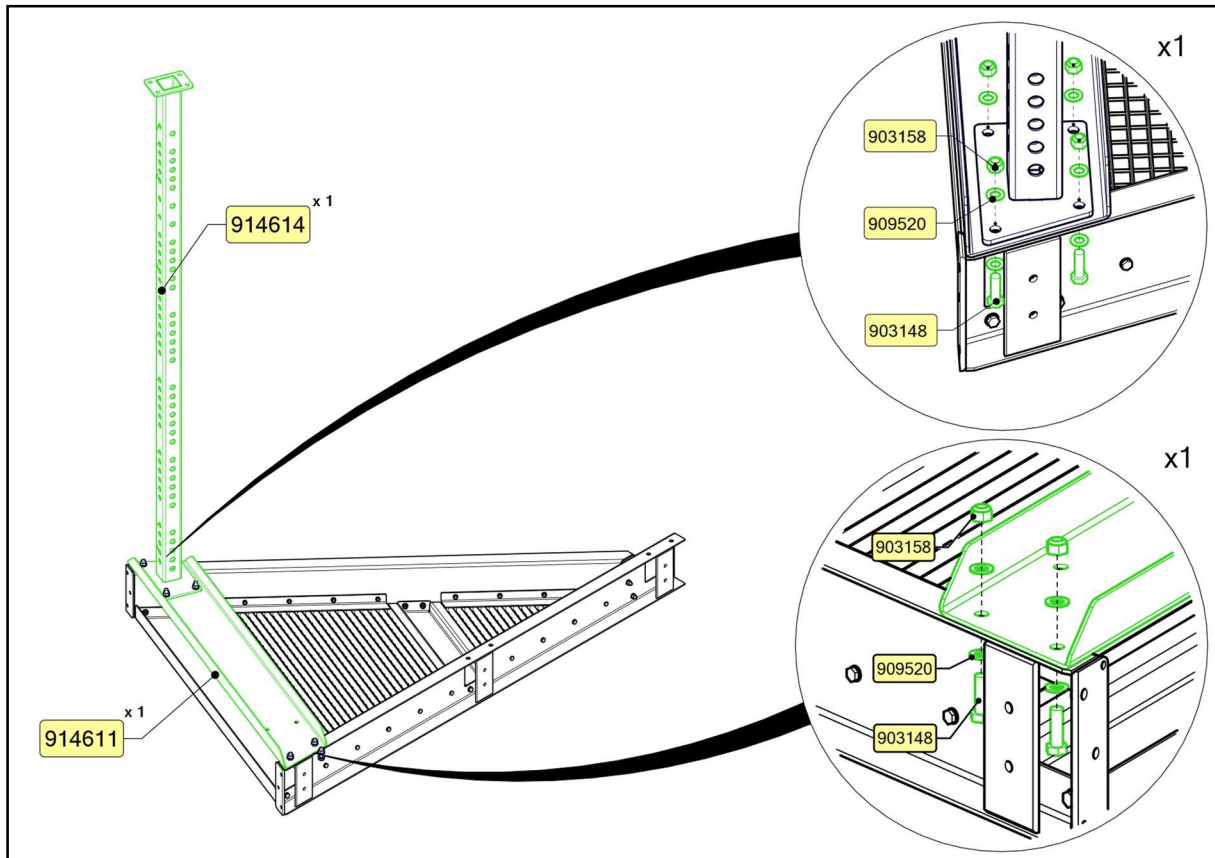

SISU FITNESS STAIRS

ASSEMBLY

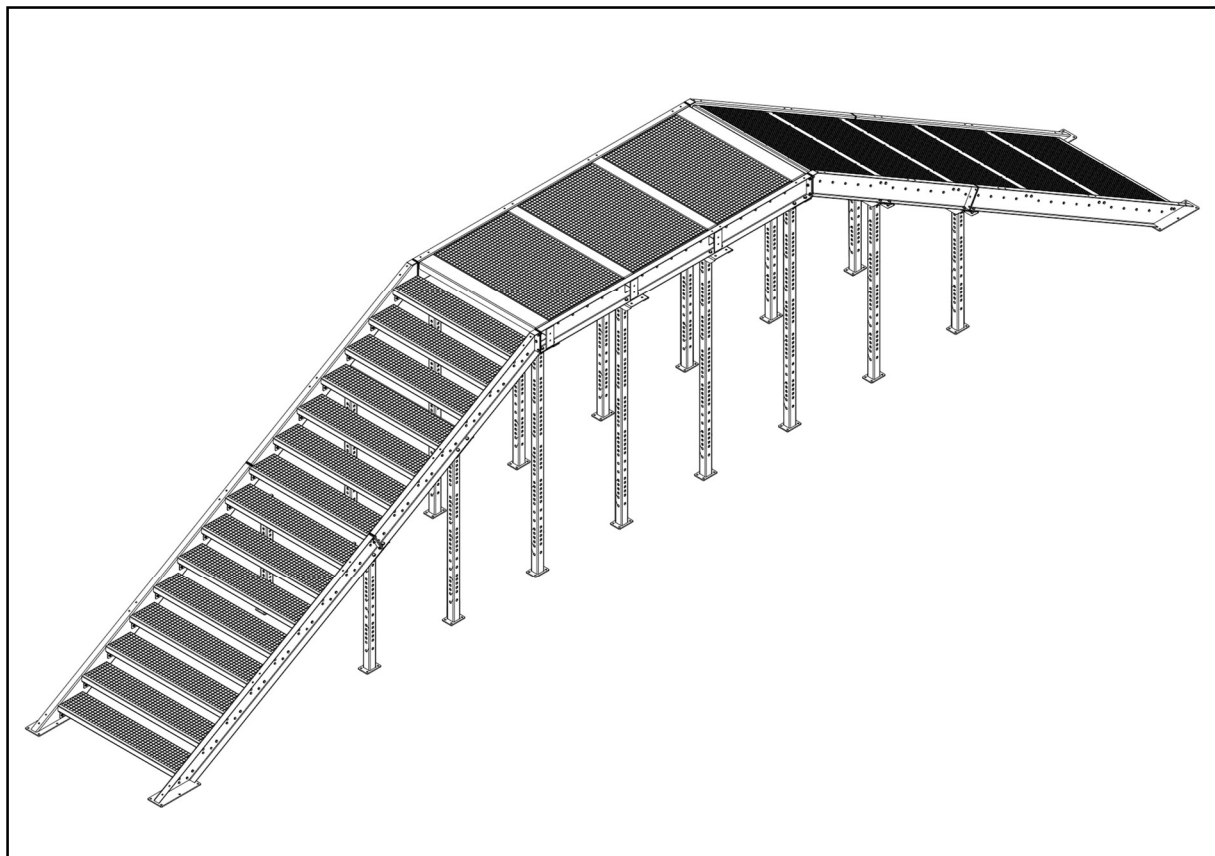
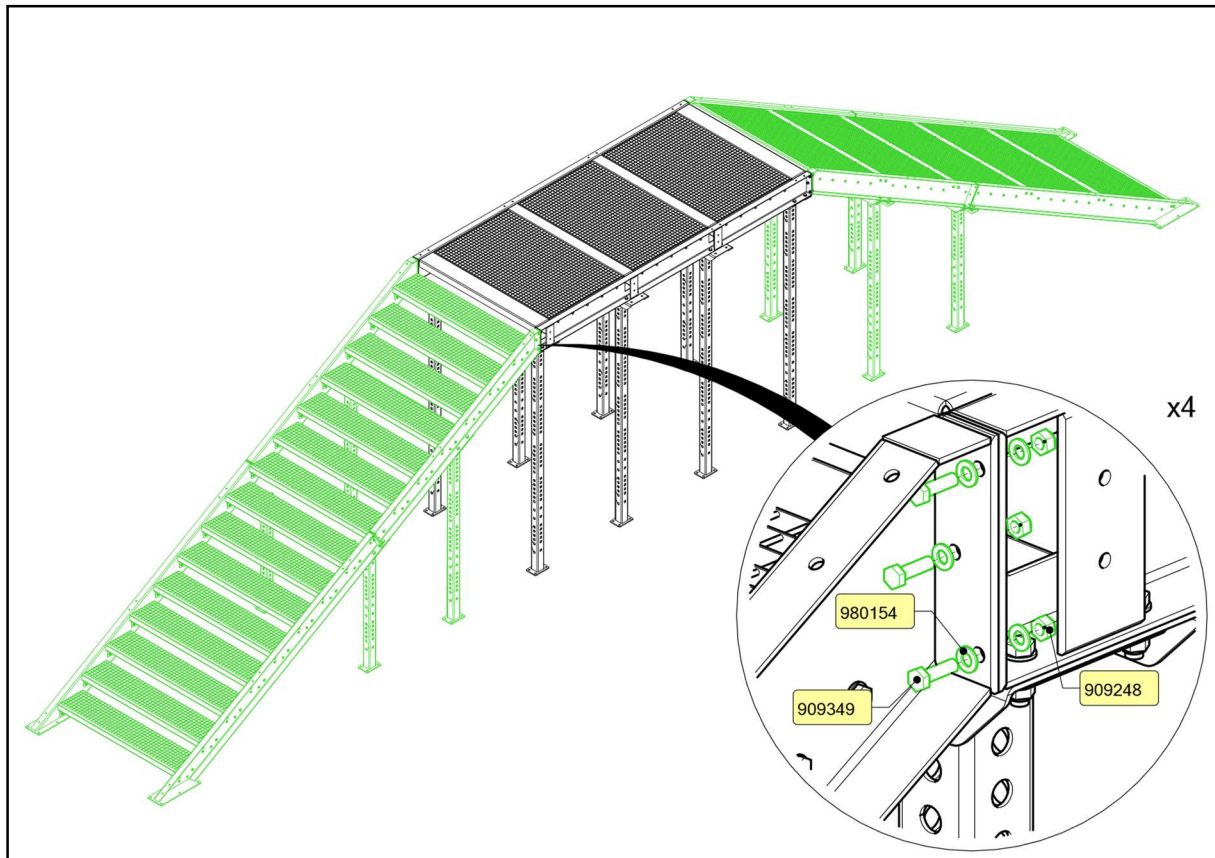

SISU FITNESS STAIRS

ASSEMBLY

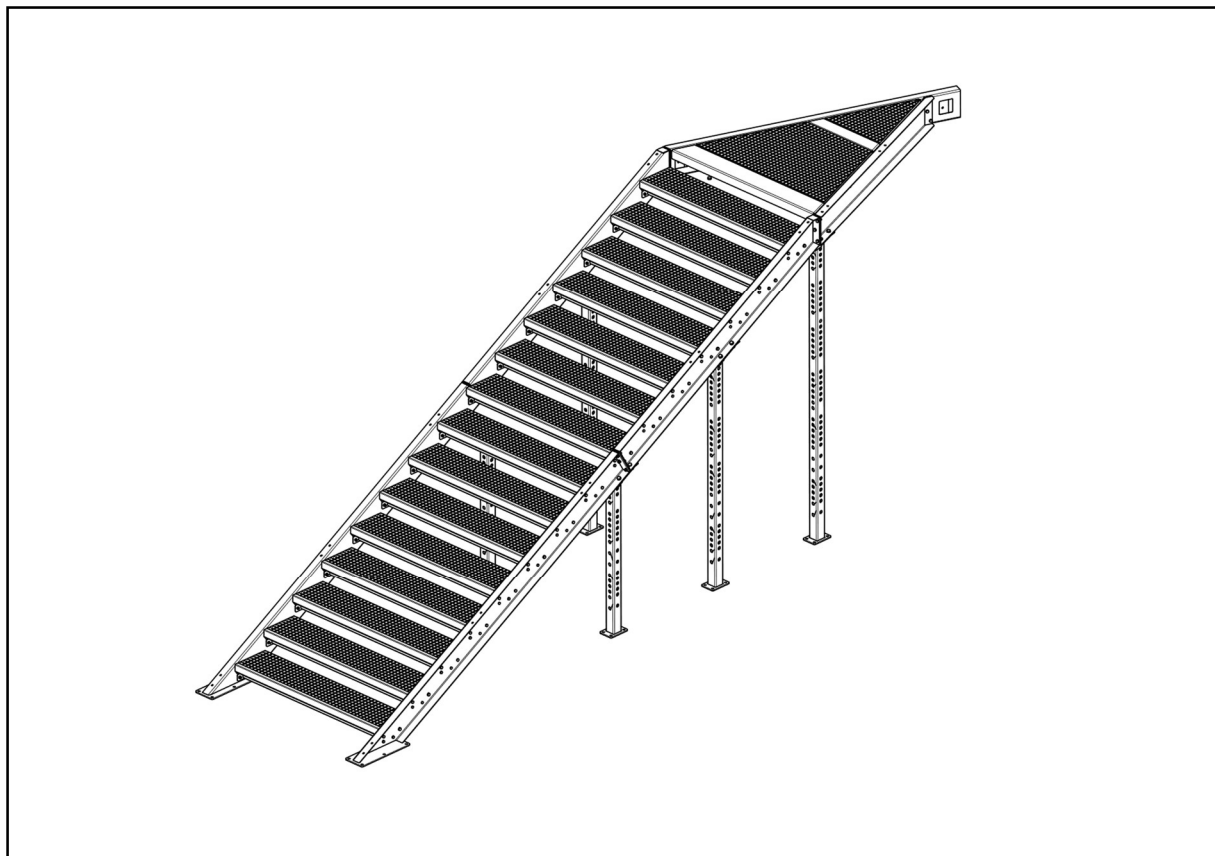
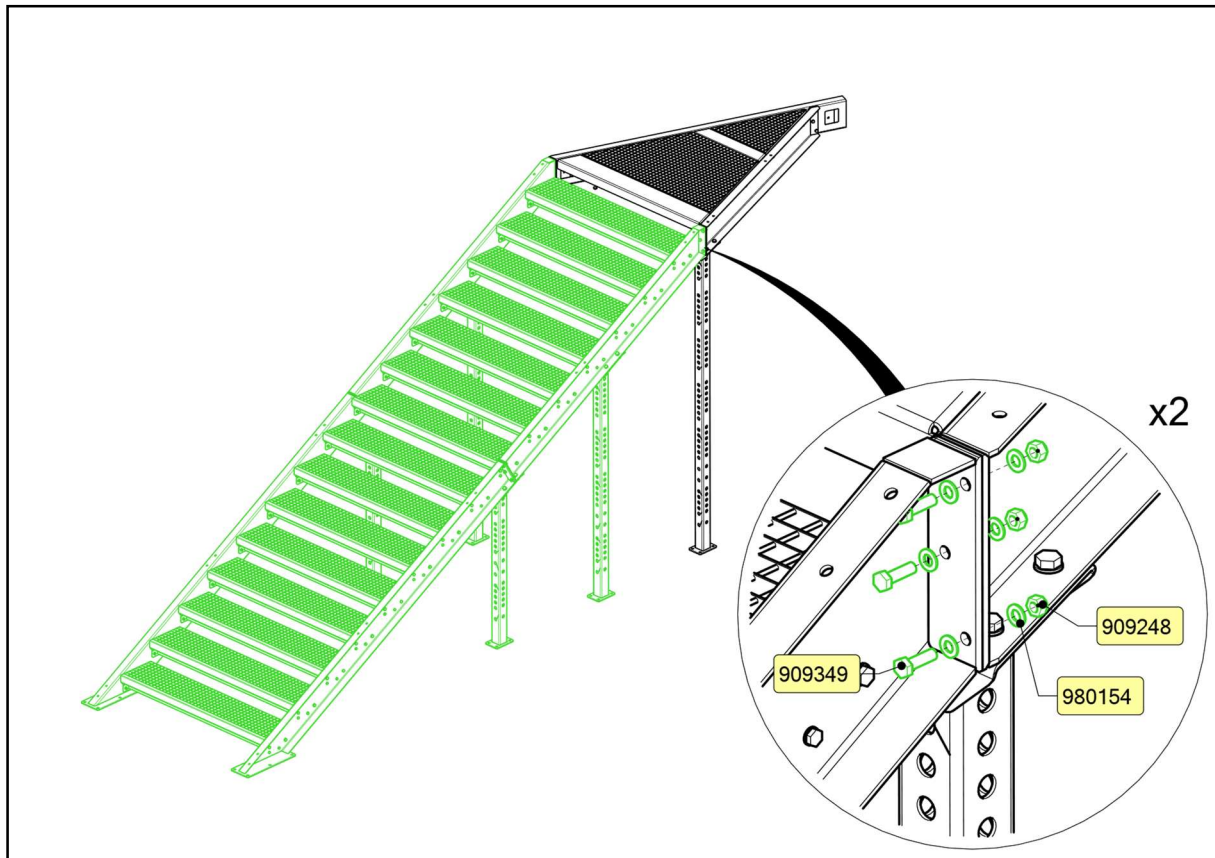

SISU FITNESS STAIRS

ASSEMBLY

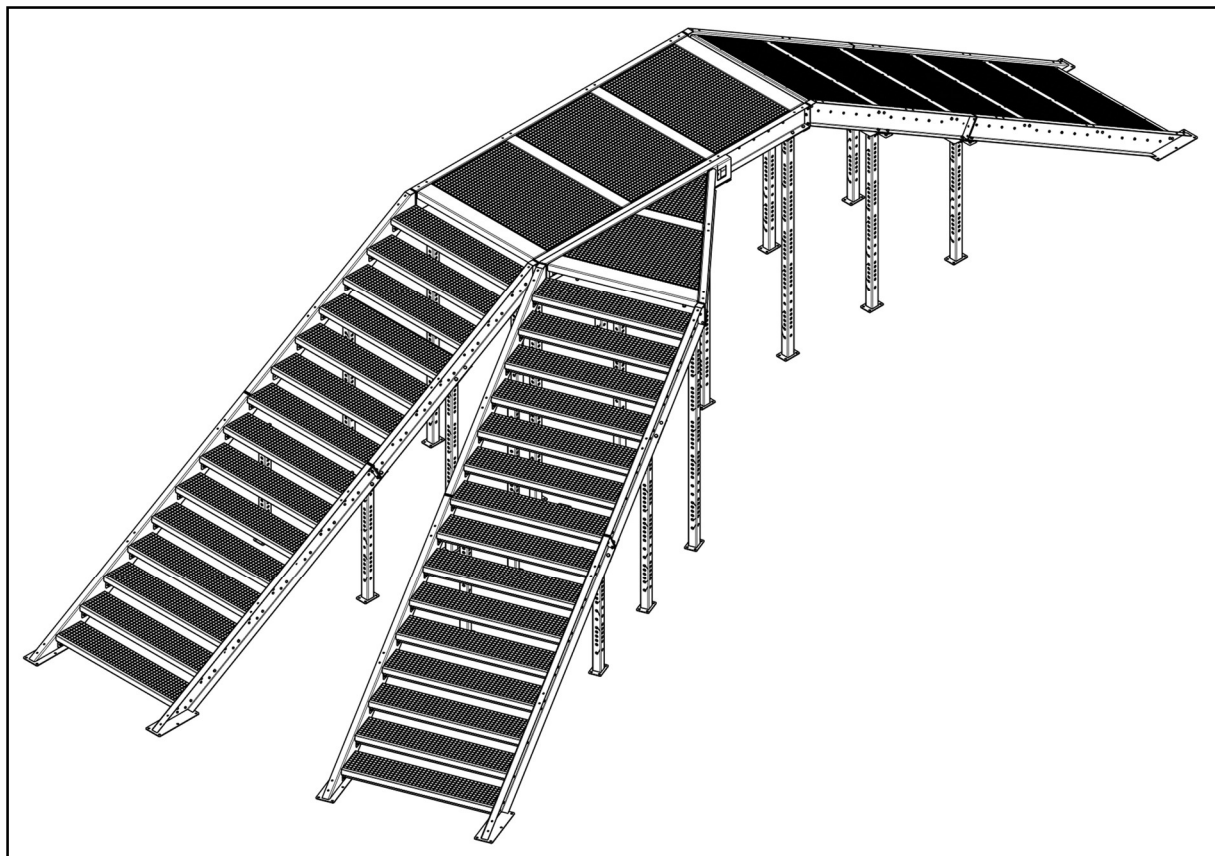
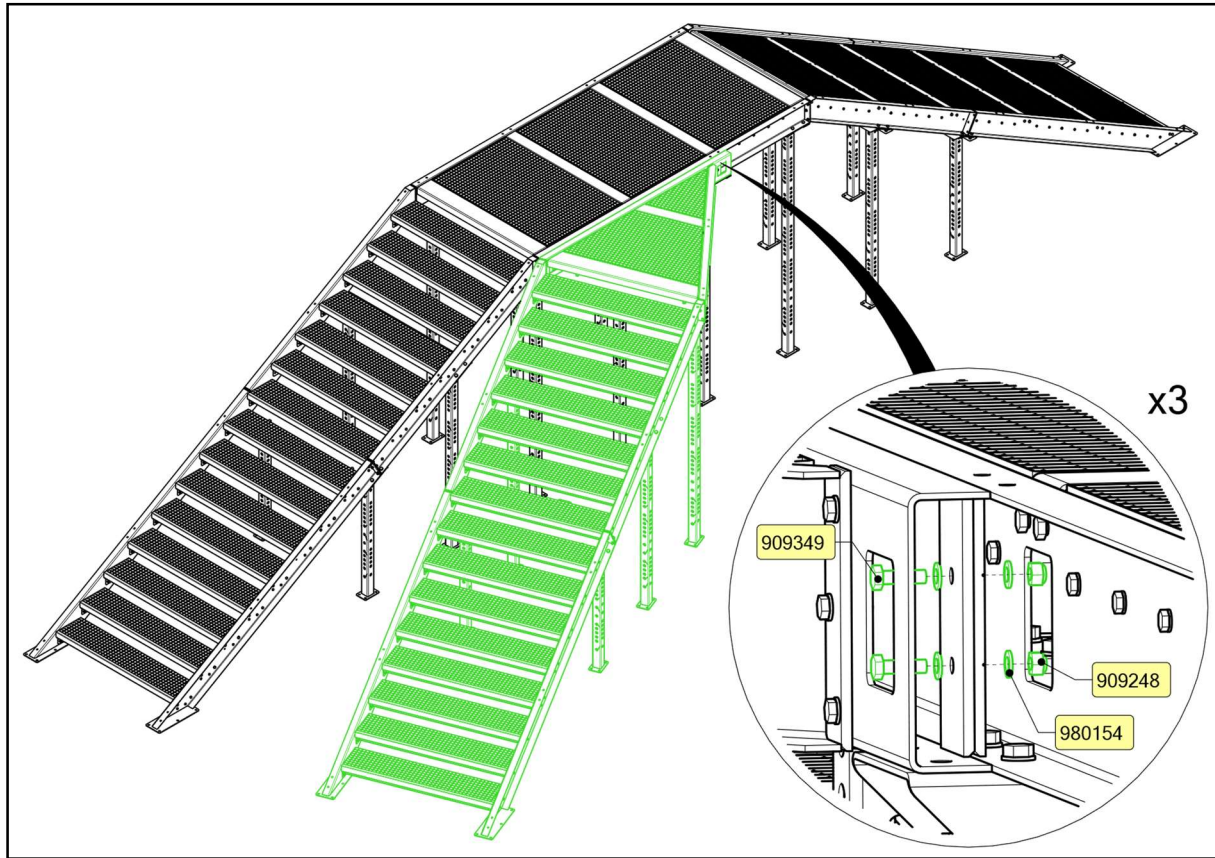

SISU FITNESS STAIRS

HANDRAIL-1 (1 PC)

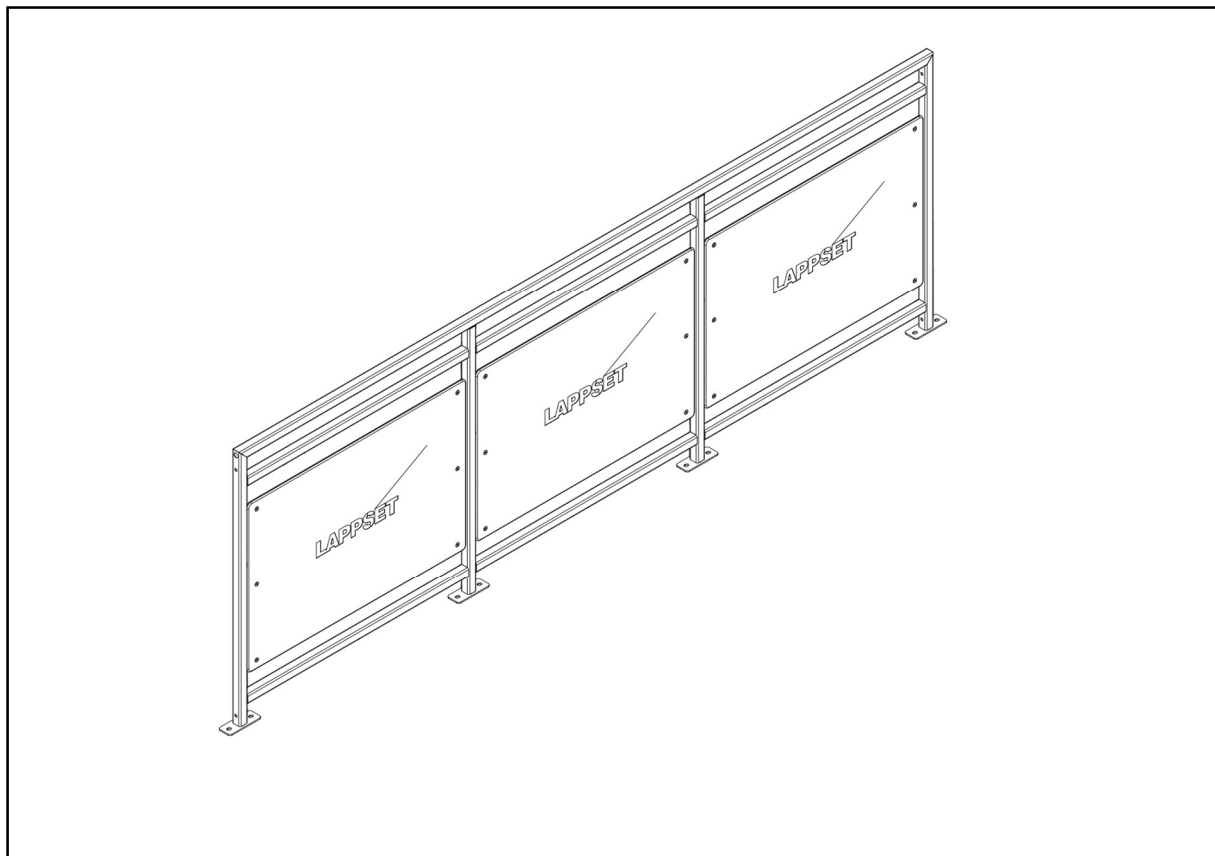
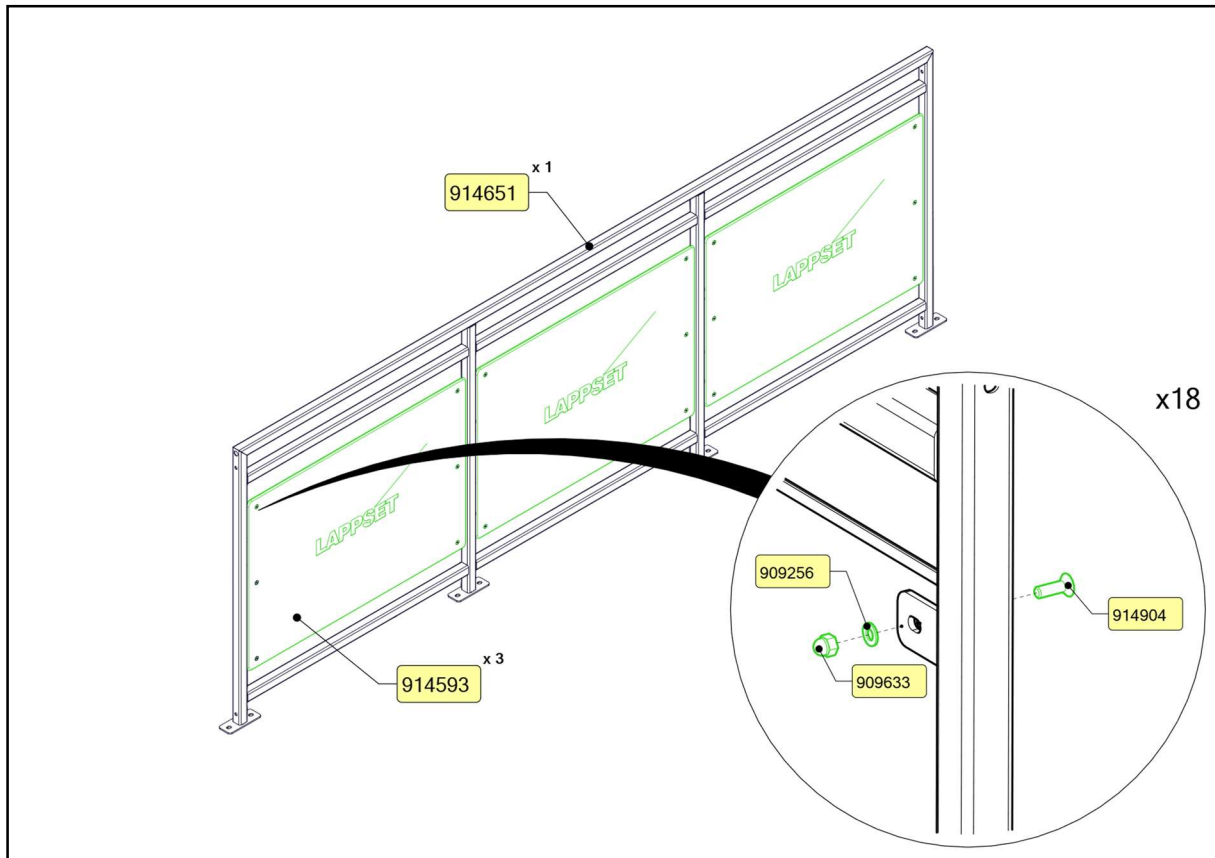

SISU FITNESS STAIRS

HANDRAIL-2 (1 PC)

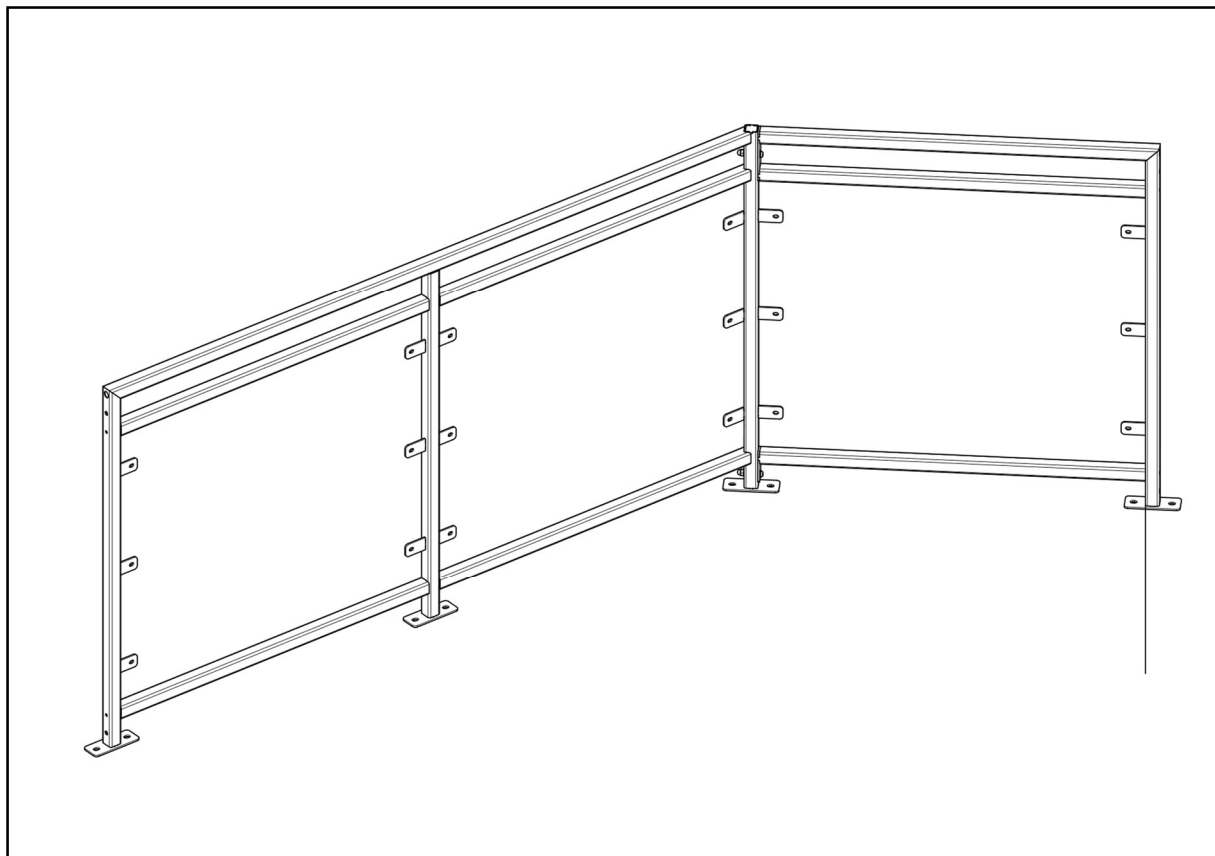
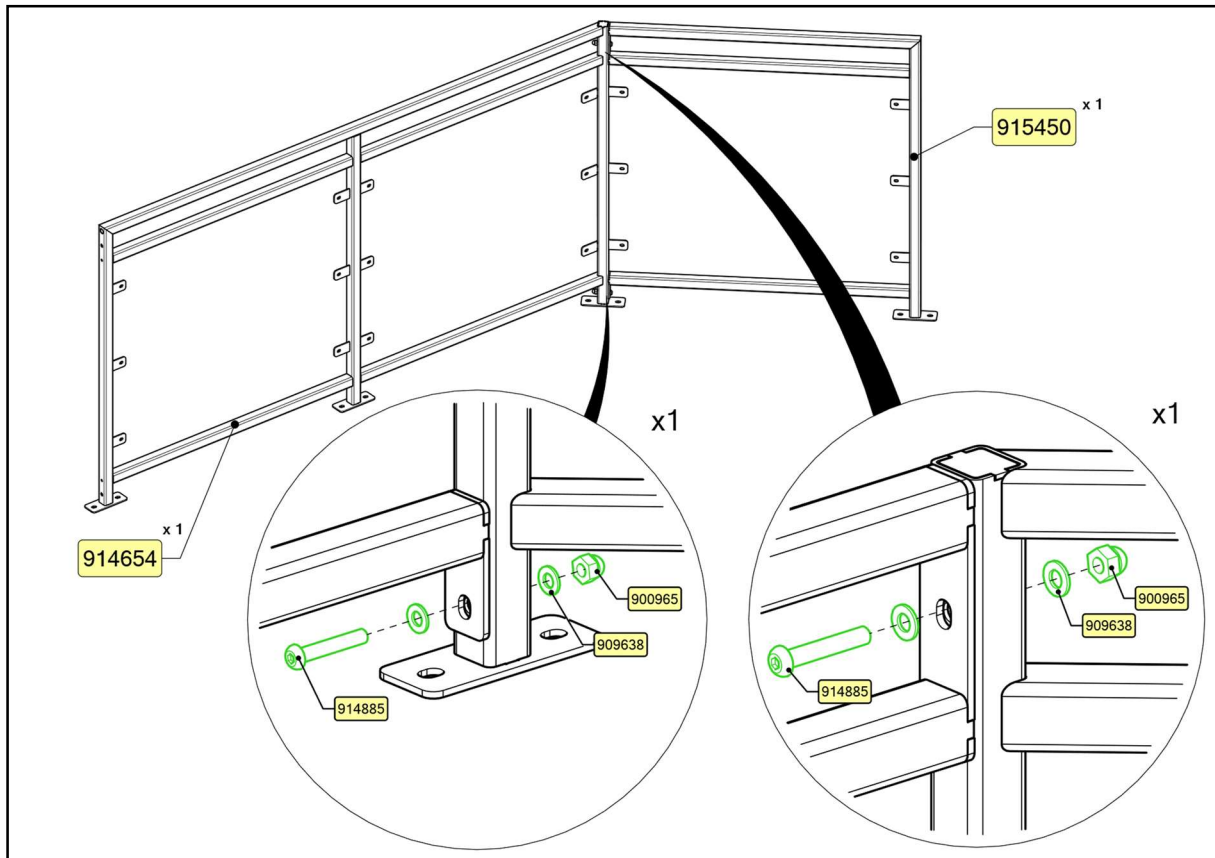

SISU FITNESS STAIRS

HANDRAIL-2 (1 PC)

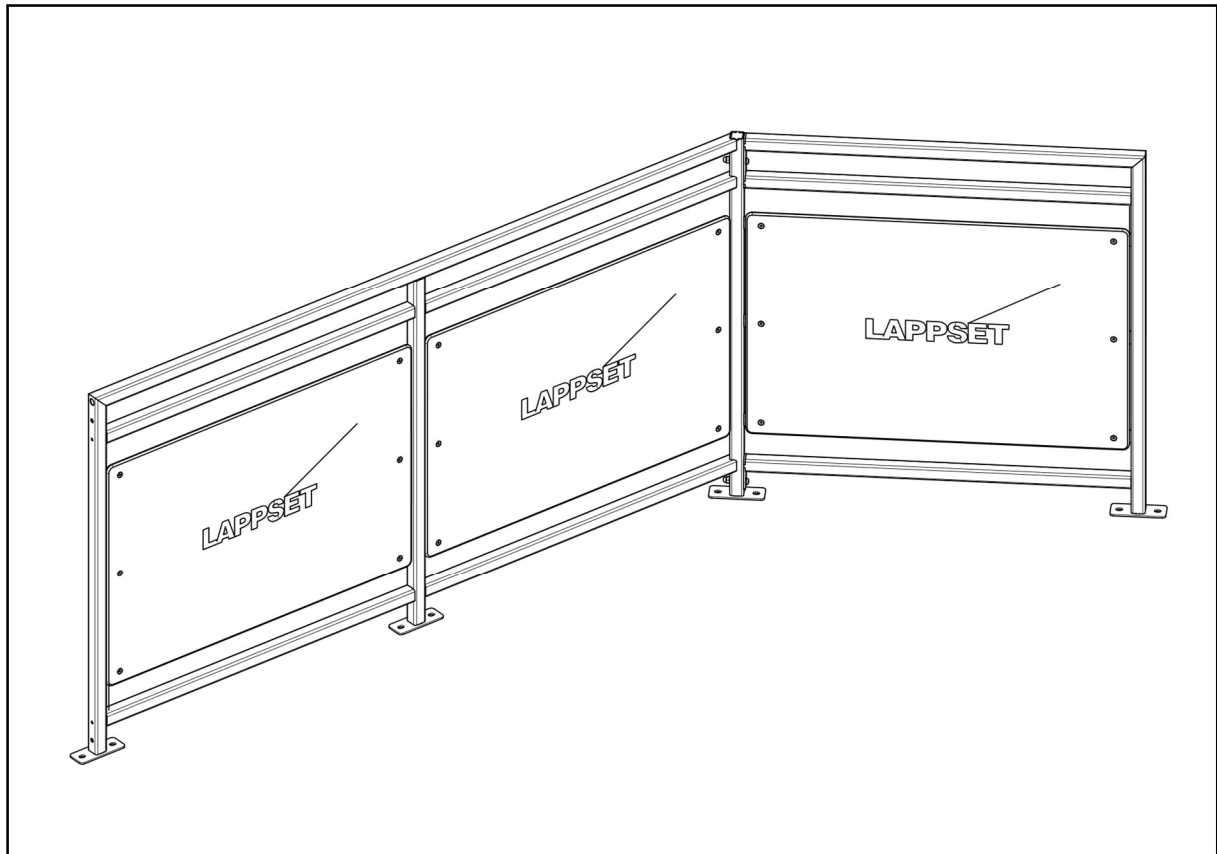
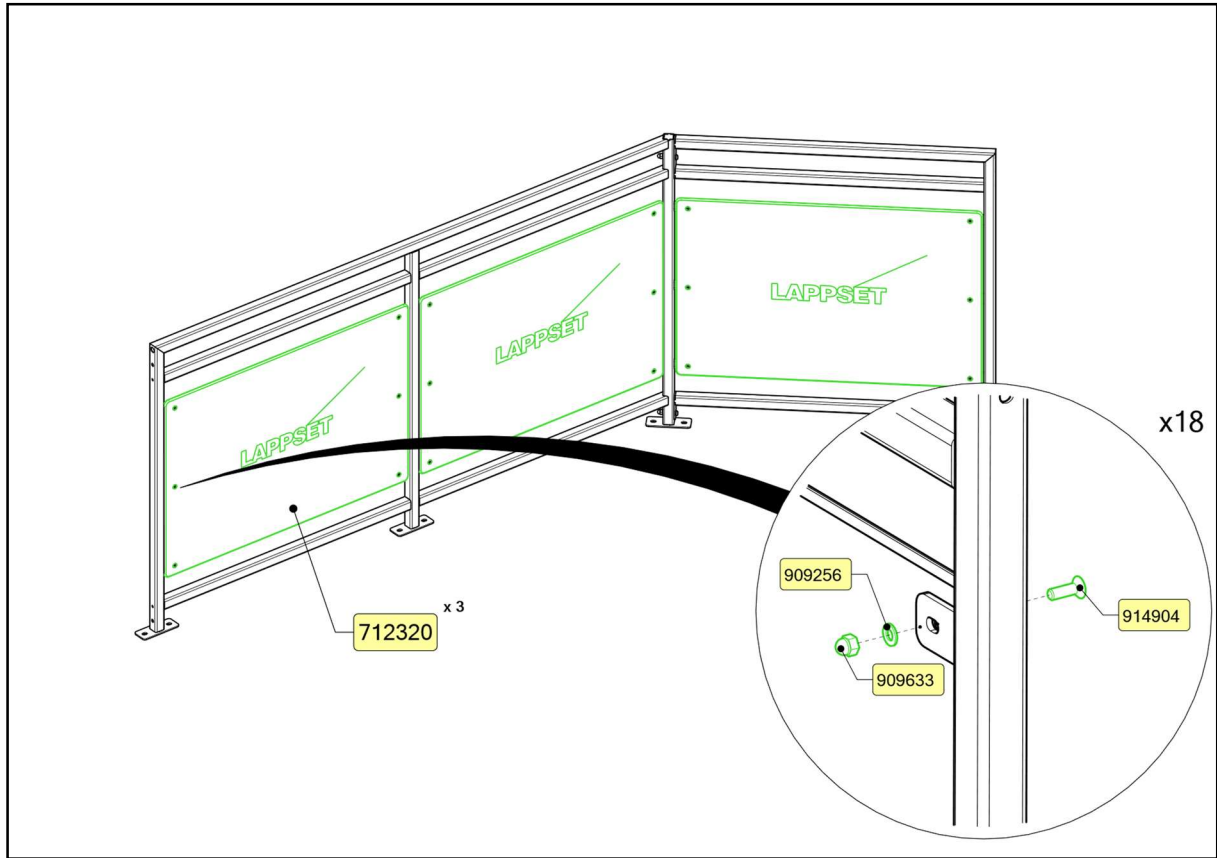

SISU FITNESS STAIRS

ASSEMBLY

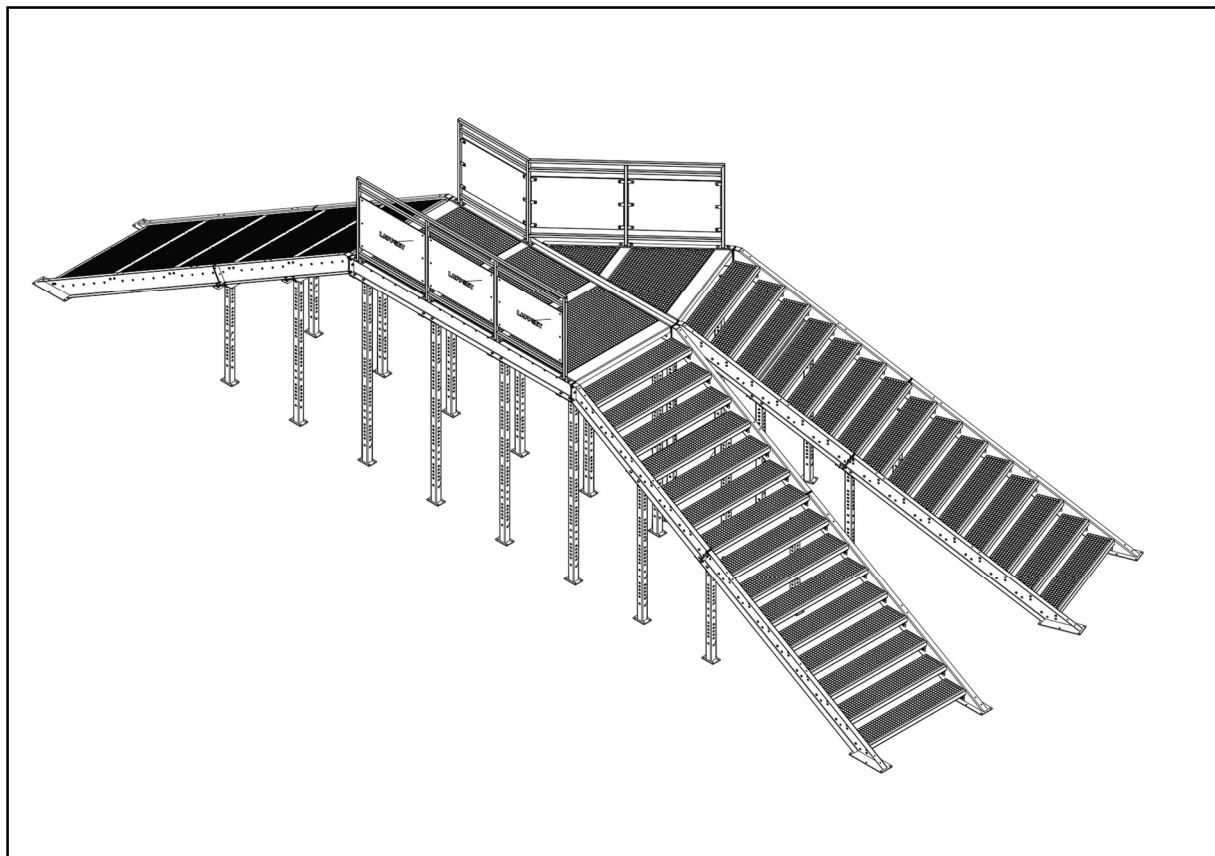
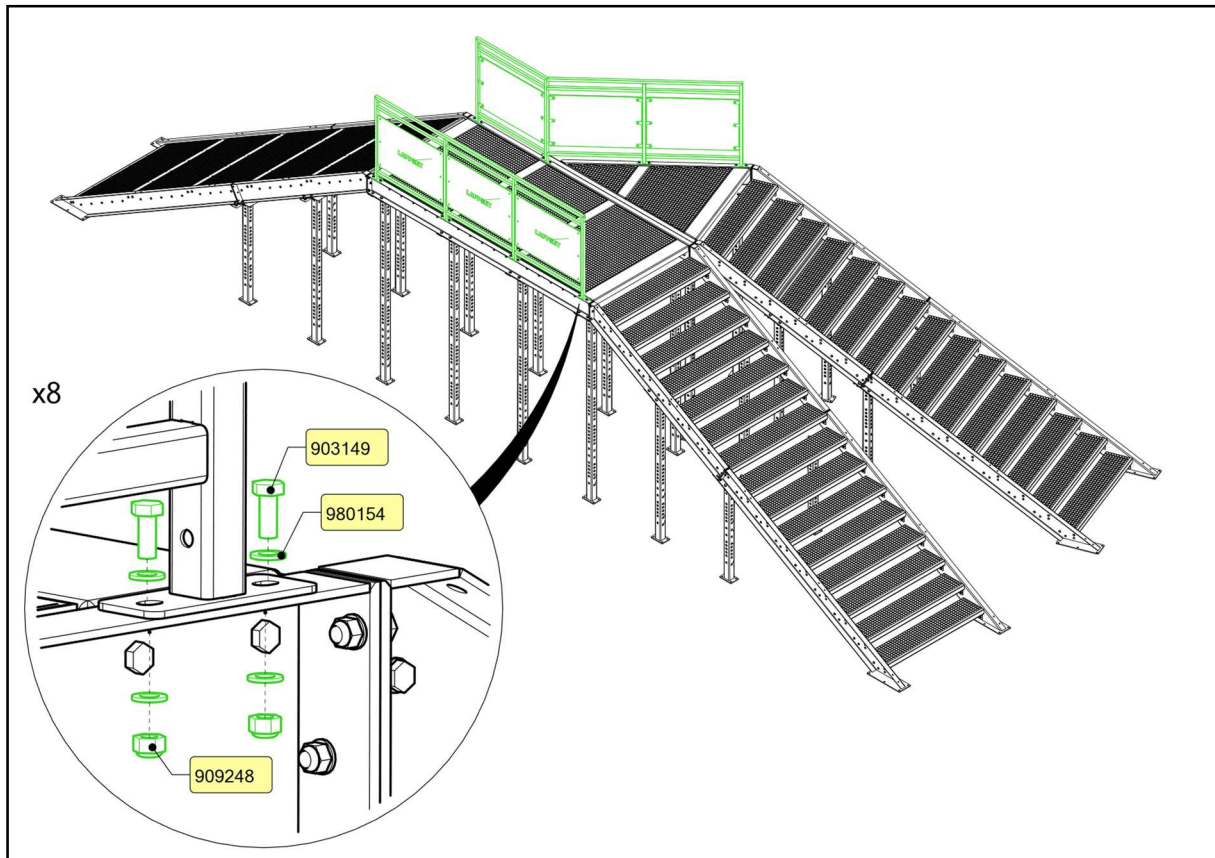

SISU FITNESS STAIRS

ASSEMBLY

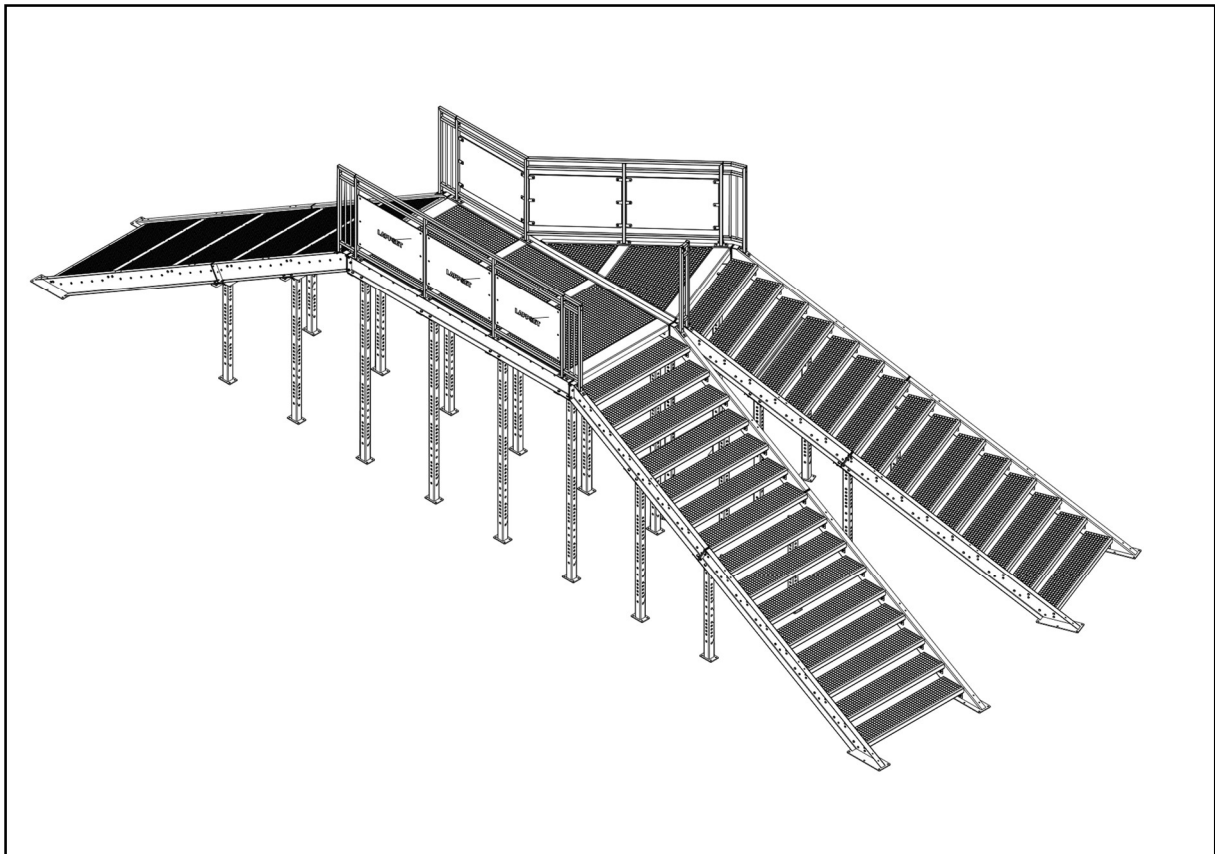
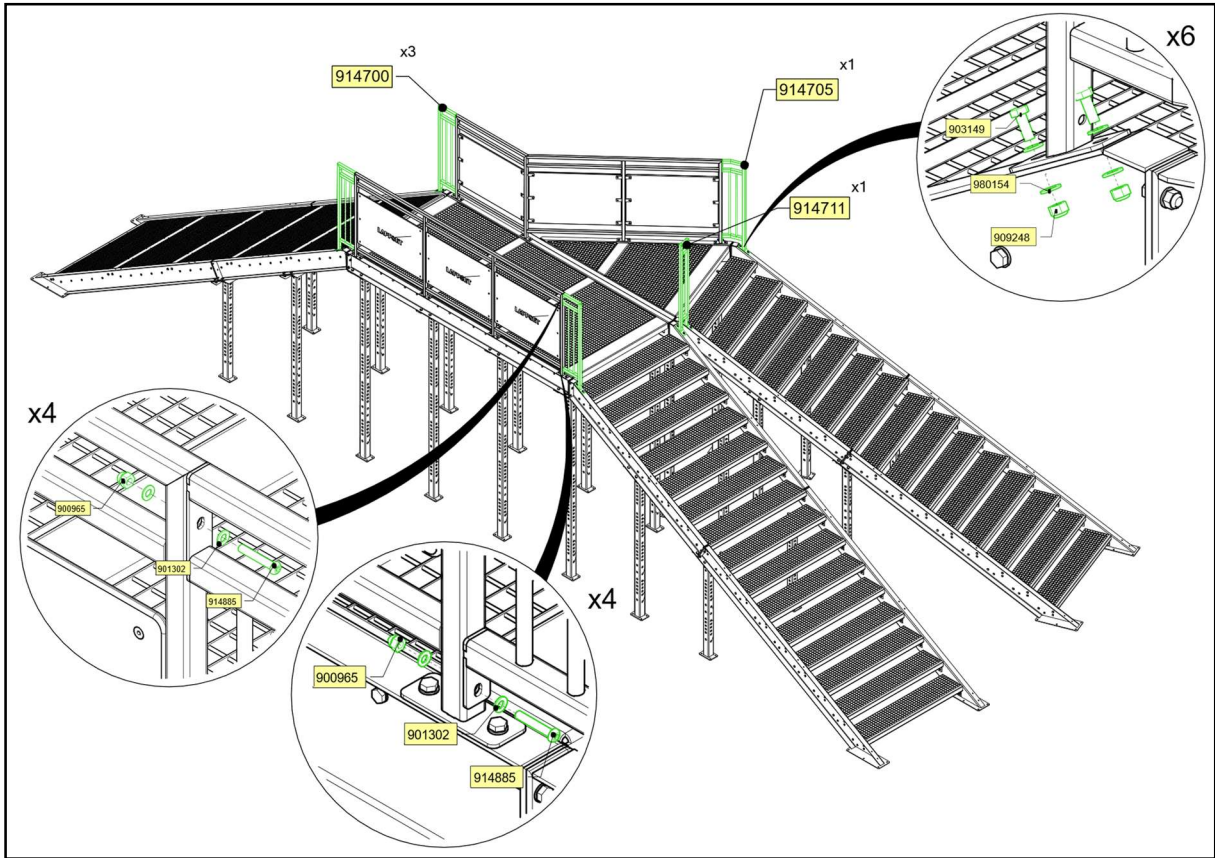

SISU FITNESS STAIRS

ASSEMBLY

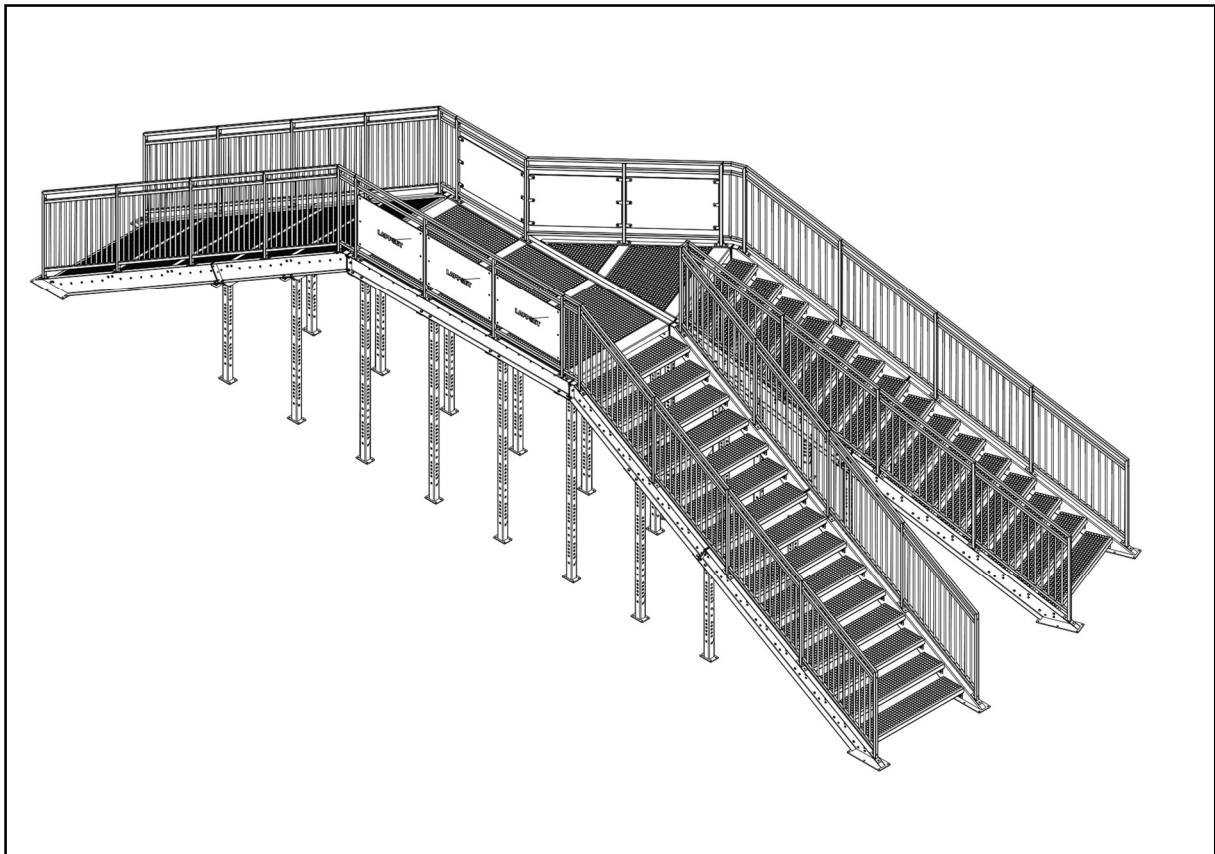
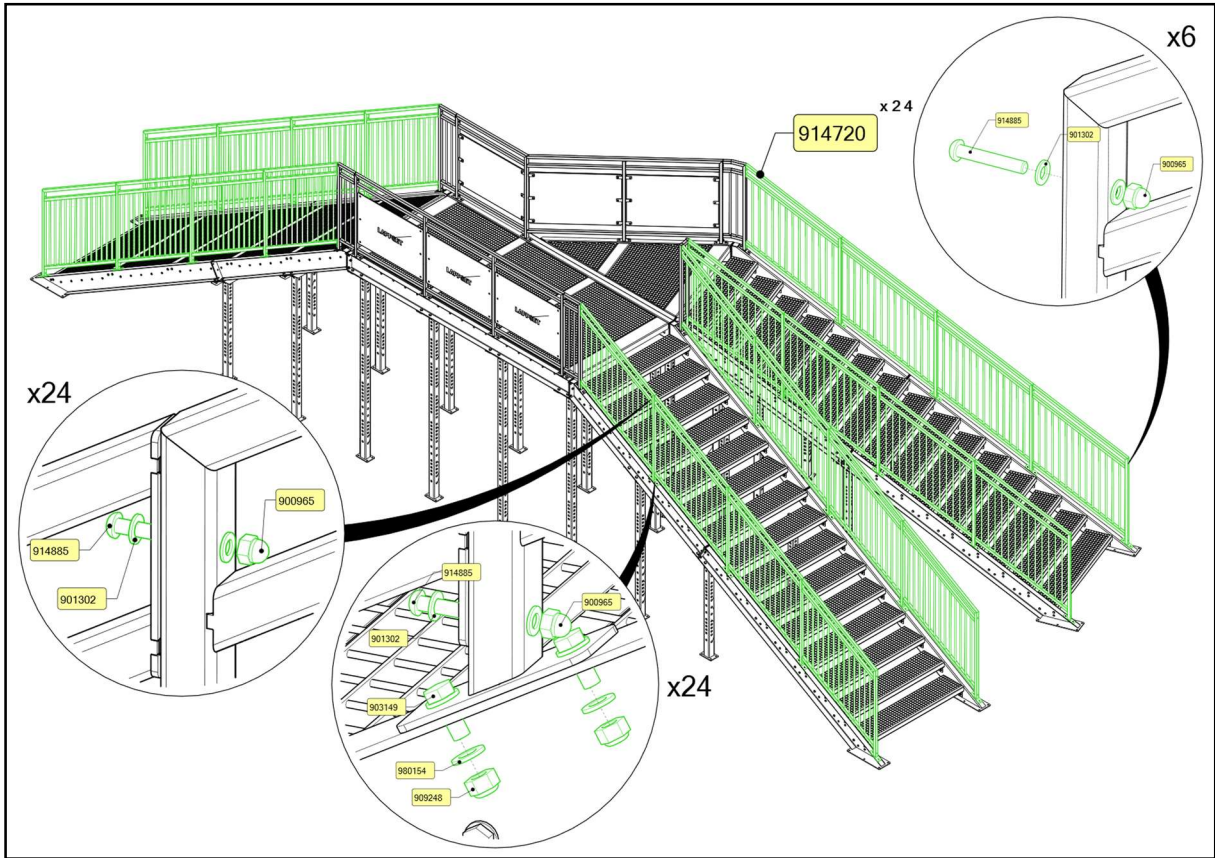

SISU FITNESS STAIRS

ADDITIONAL STEPS (7 PCS)

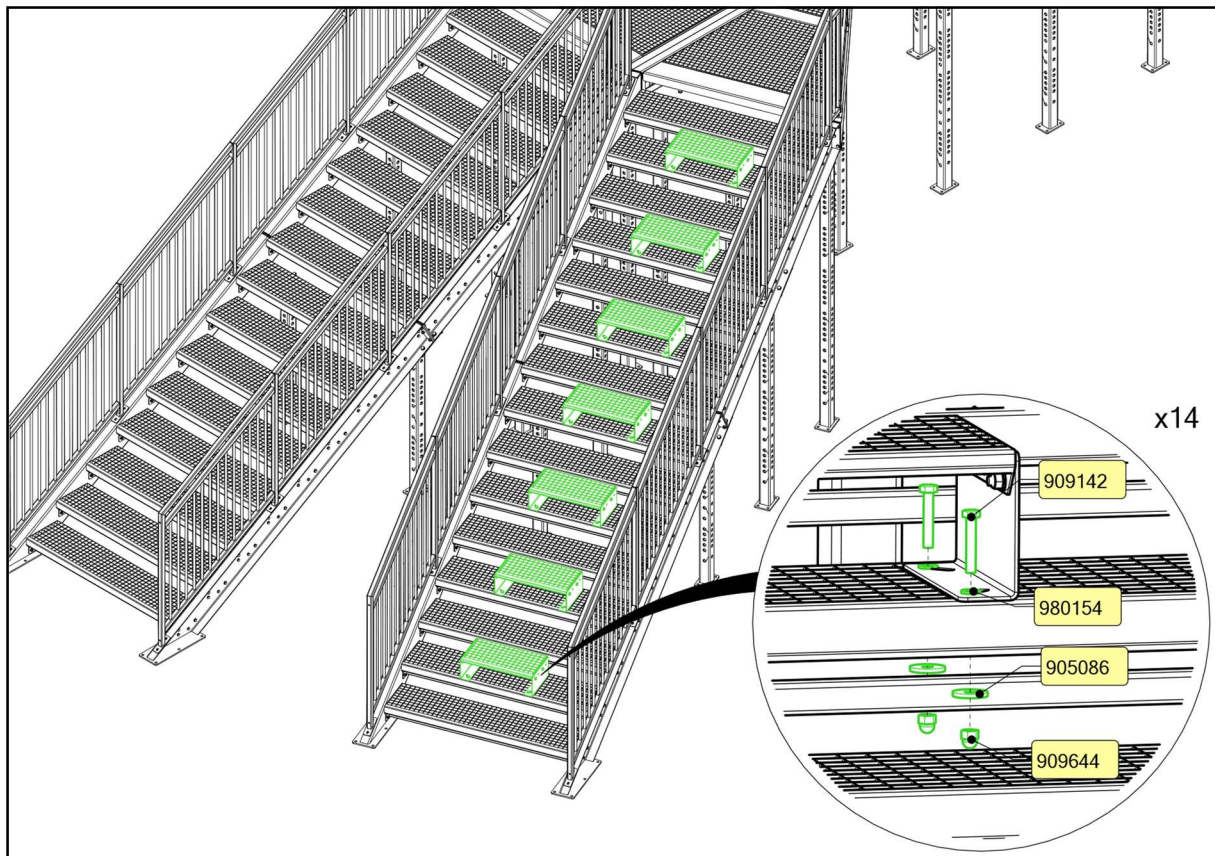
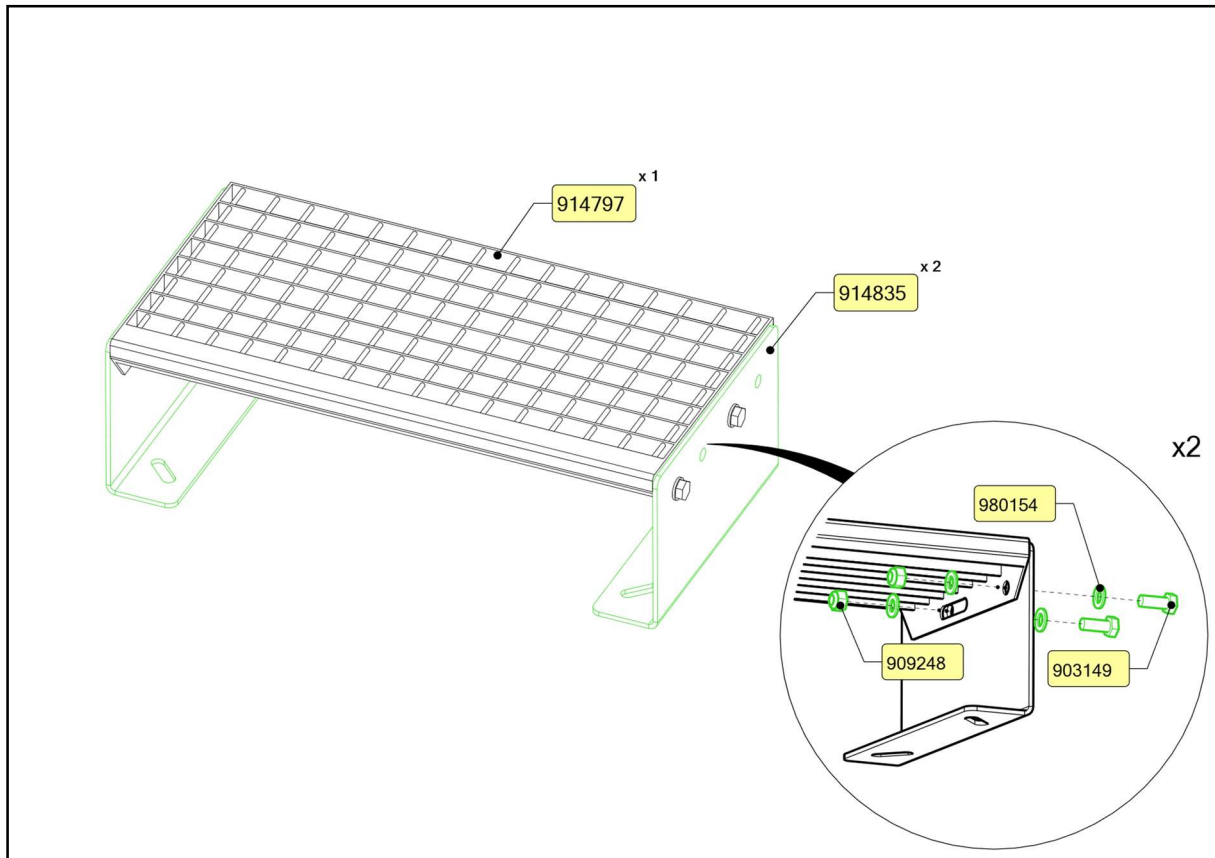

SISU FITNESS STAIRS

ADDITIONAL STEPS (7 PCS)

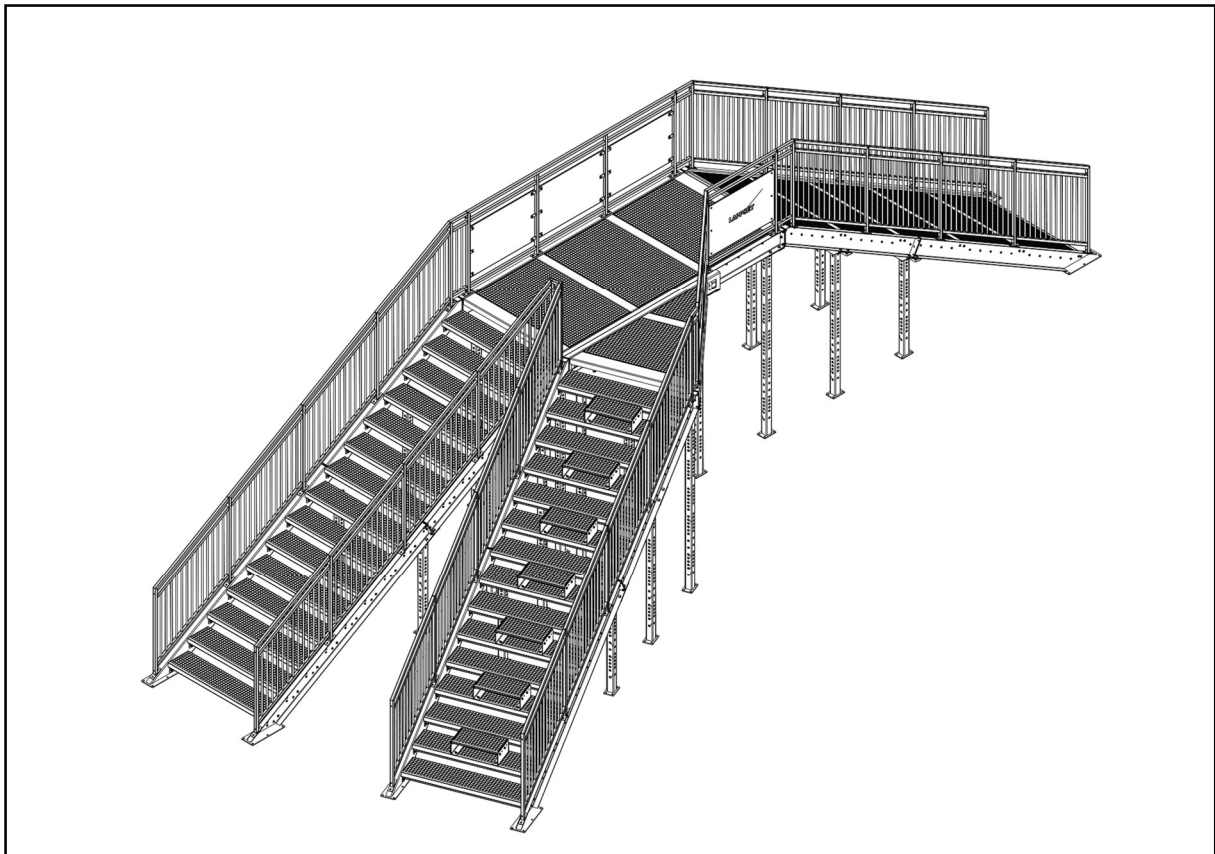
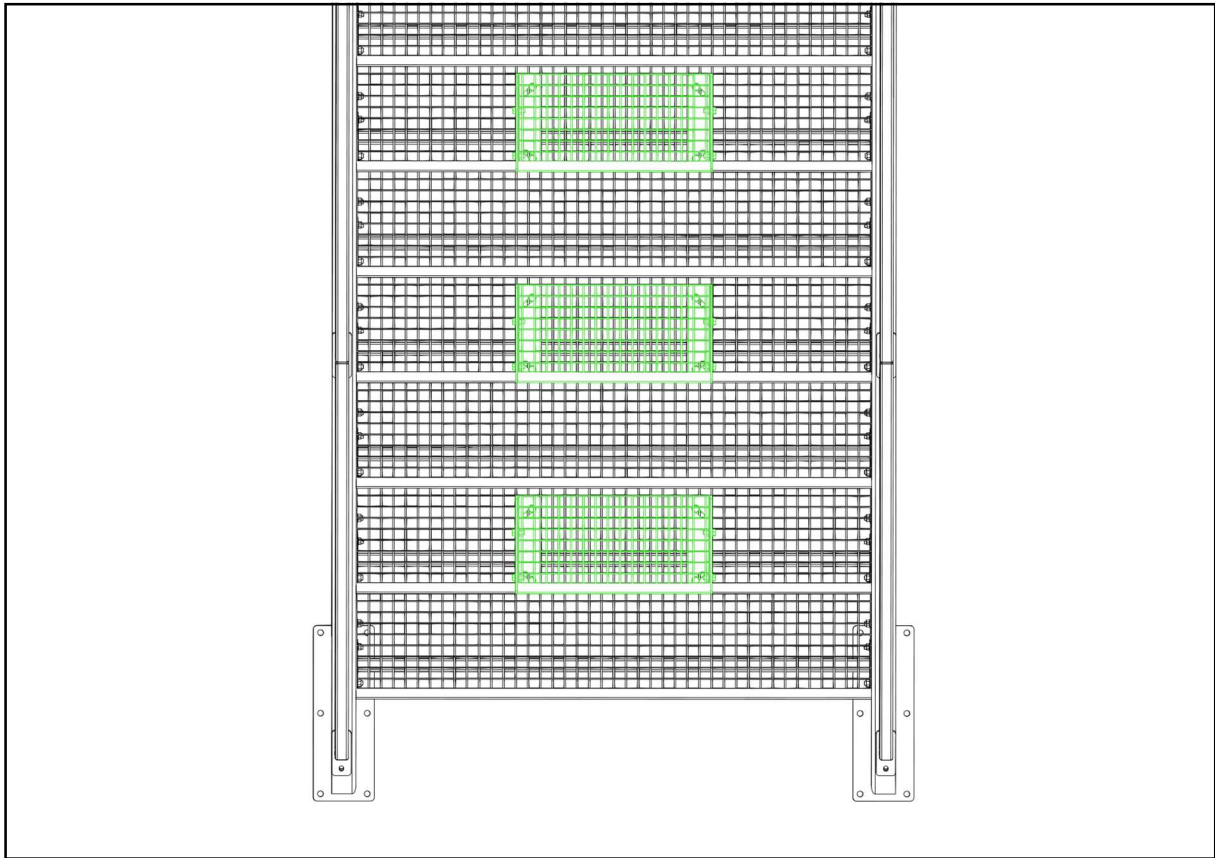

SISU FITNESS STAIRS

BALL TARGET (2 PCS)

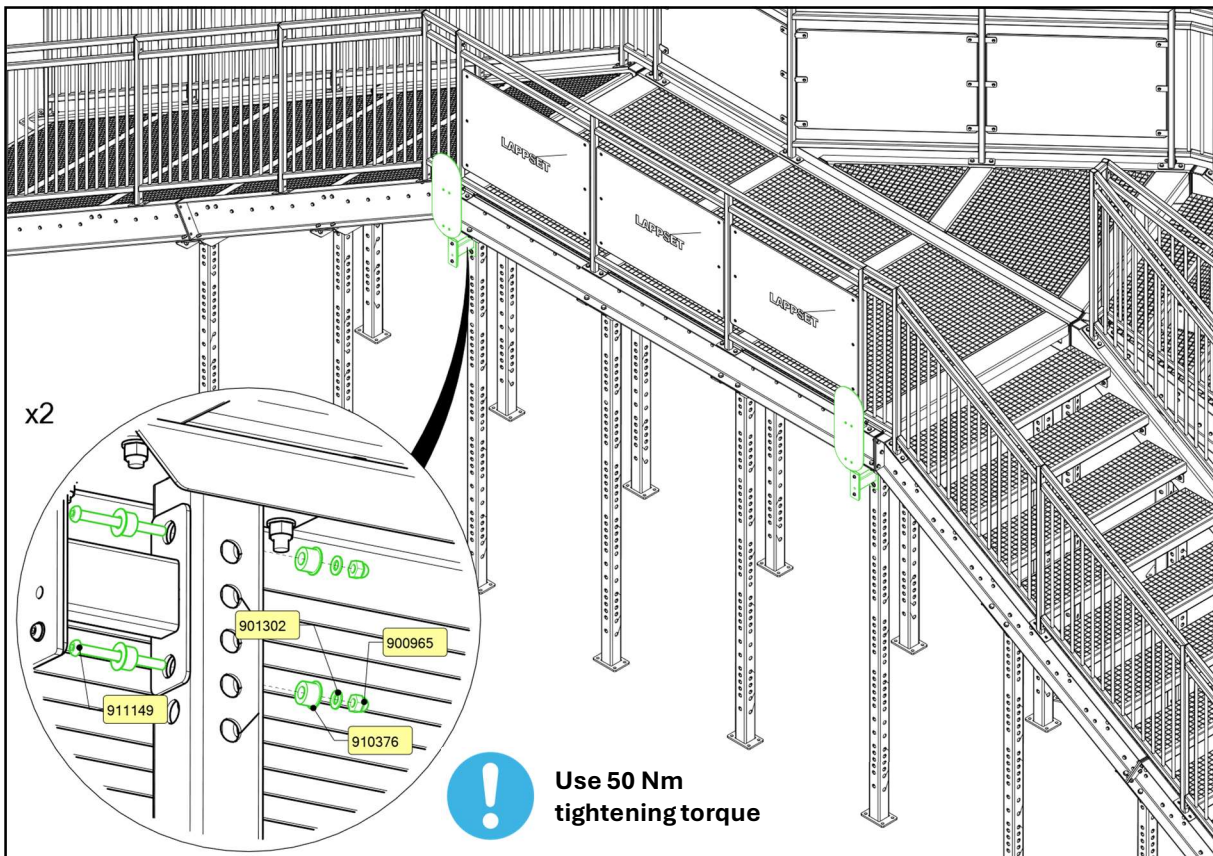
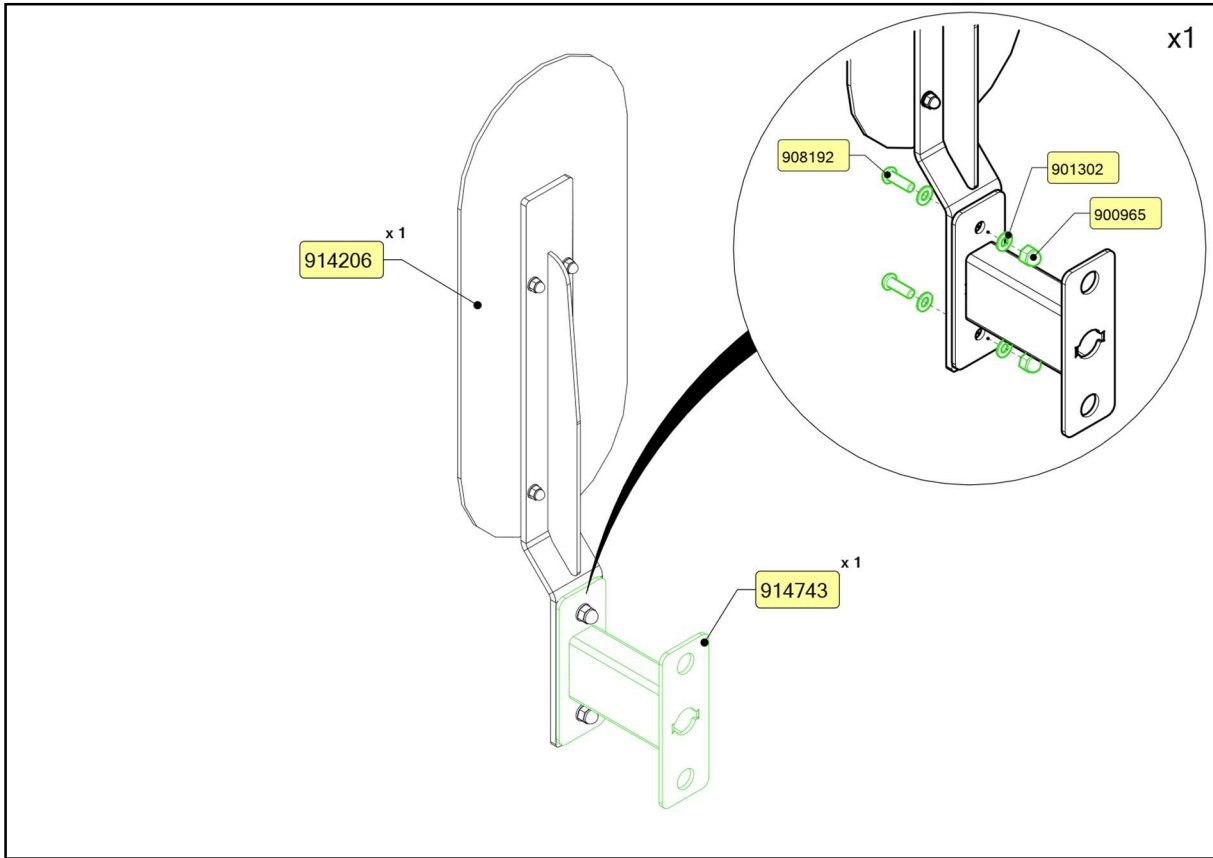

SISU FITNESS STAIRS

GYMNASTIC WALL

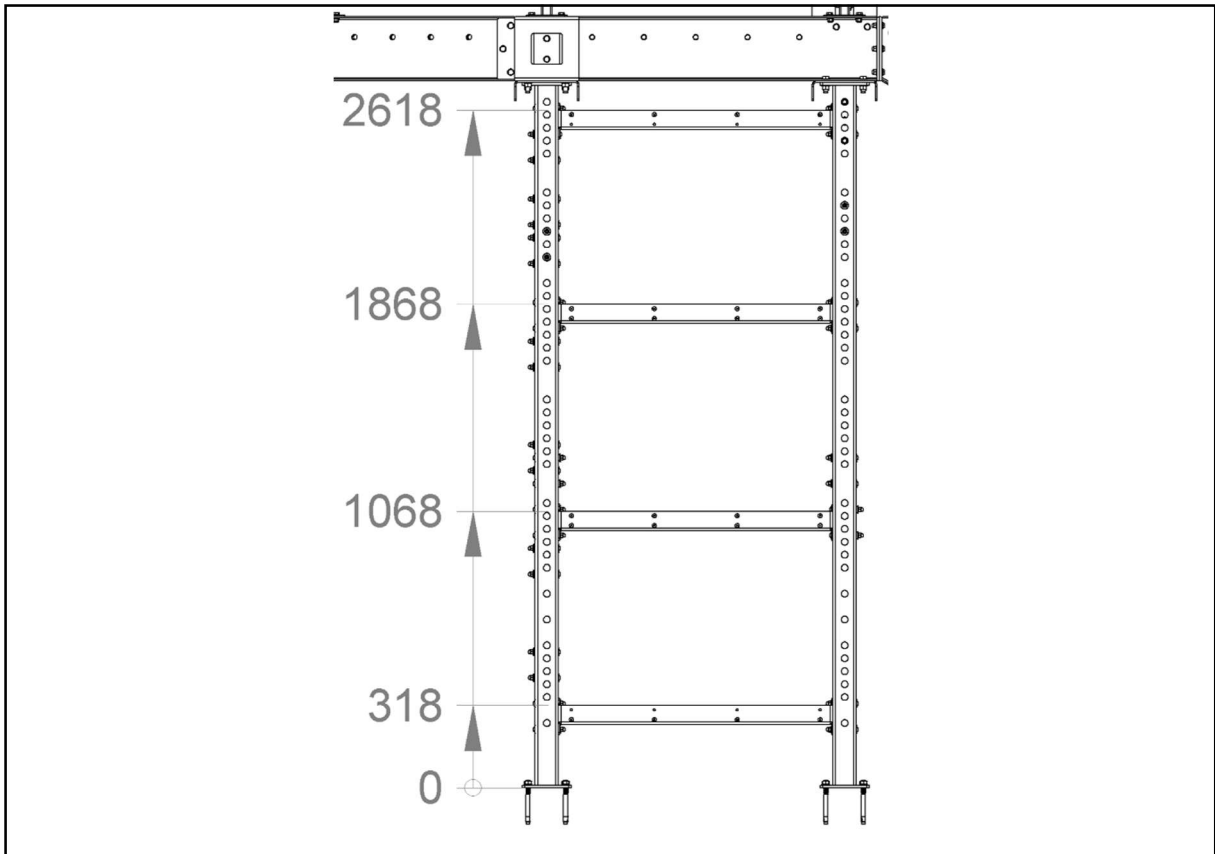
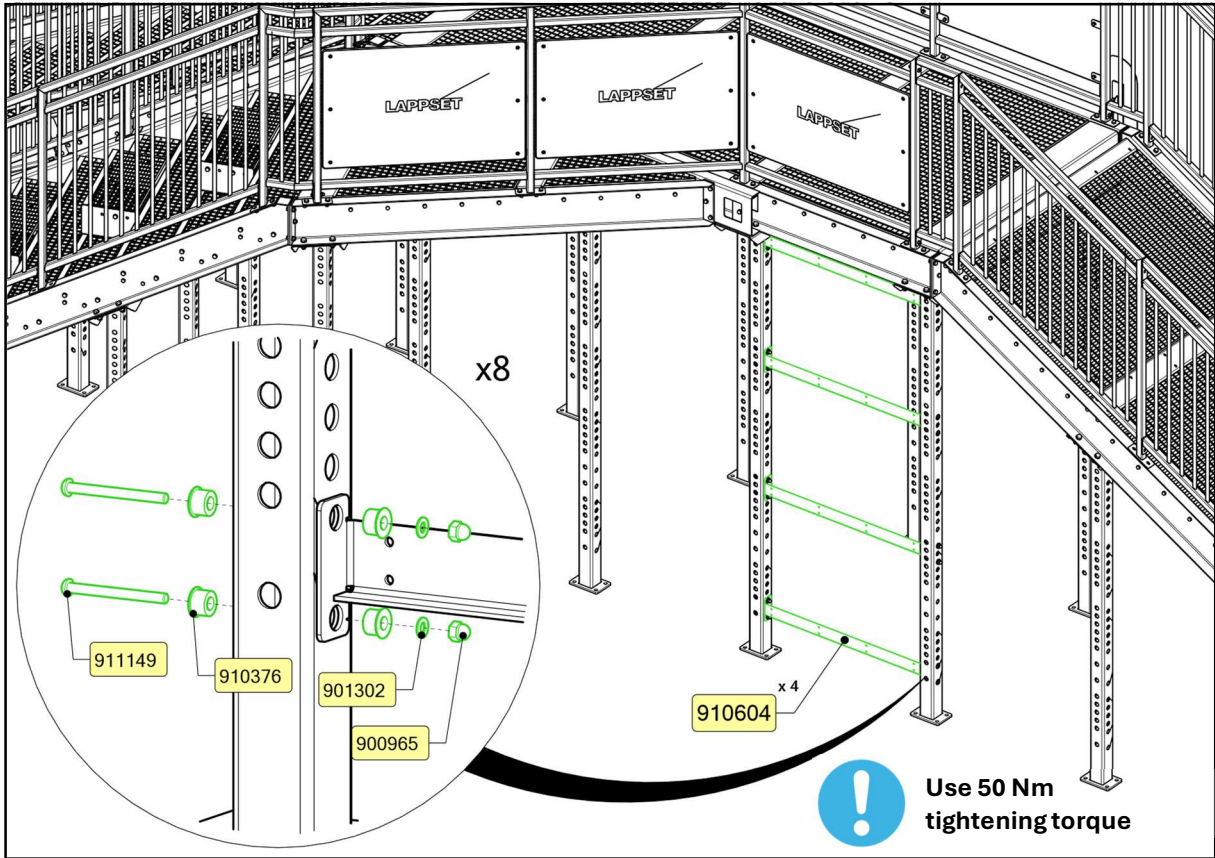

SISU FITNESS STAIRS

GYMNASTIC WALL

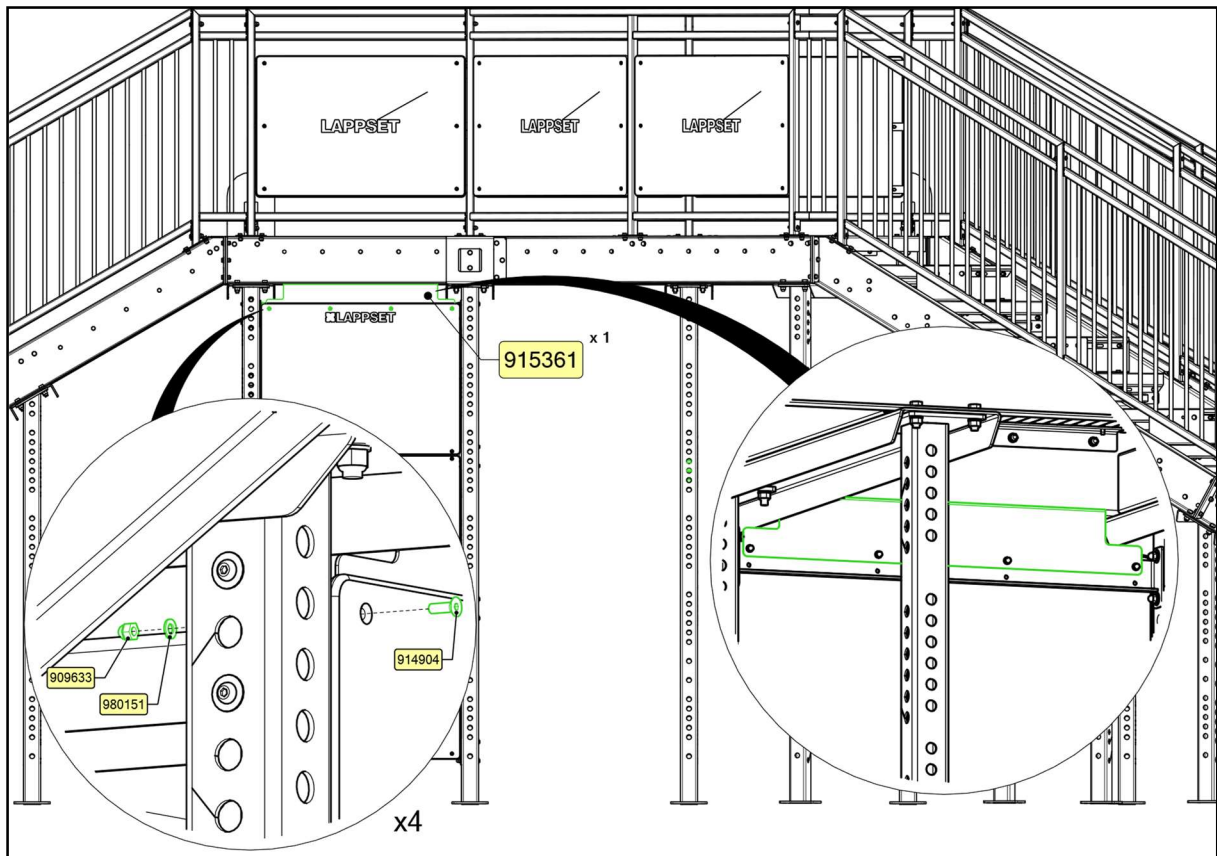
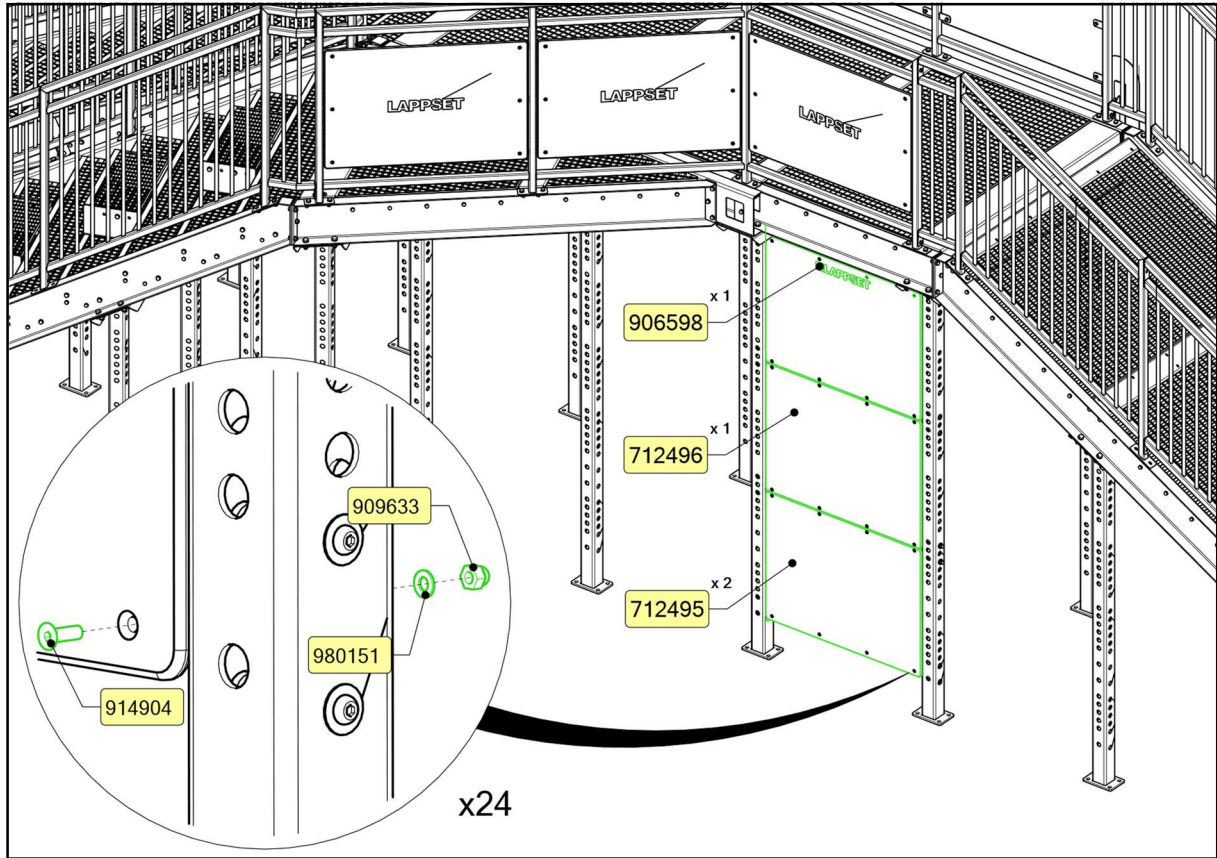

SISU FITNESS STAIRS

BARS-1 (4 PCS)

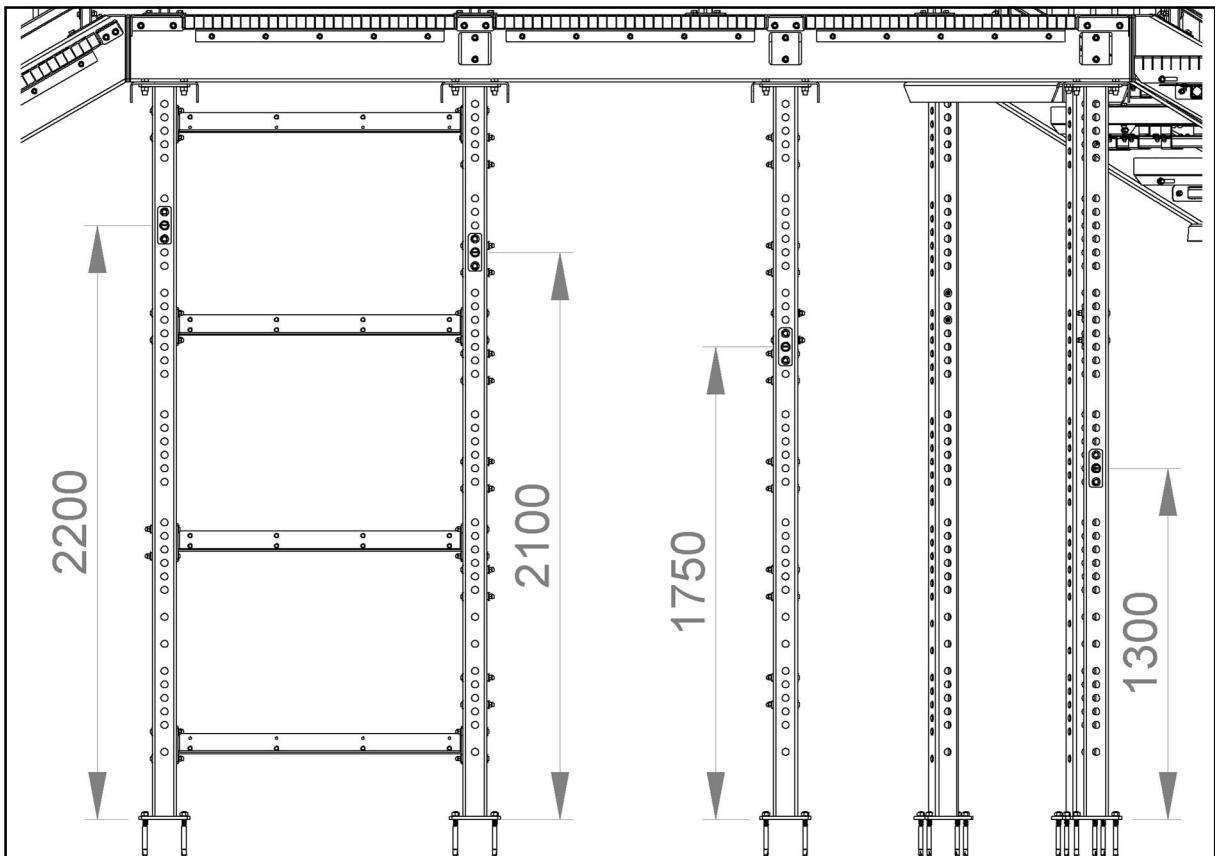
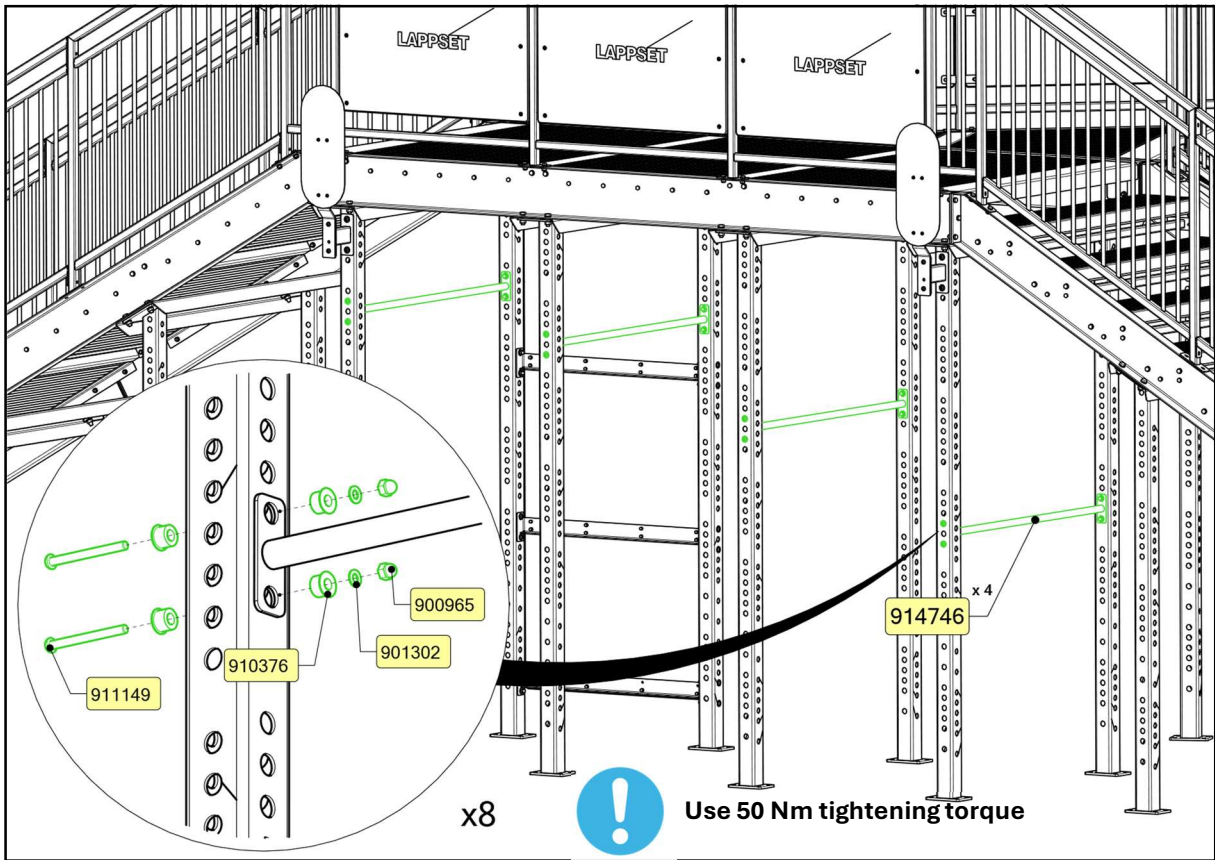

SISU FITNESS STAIRS

BARS-2 (8 PCS)

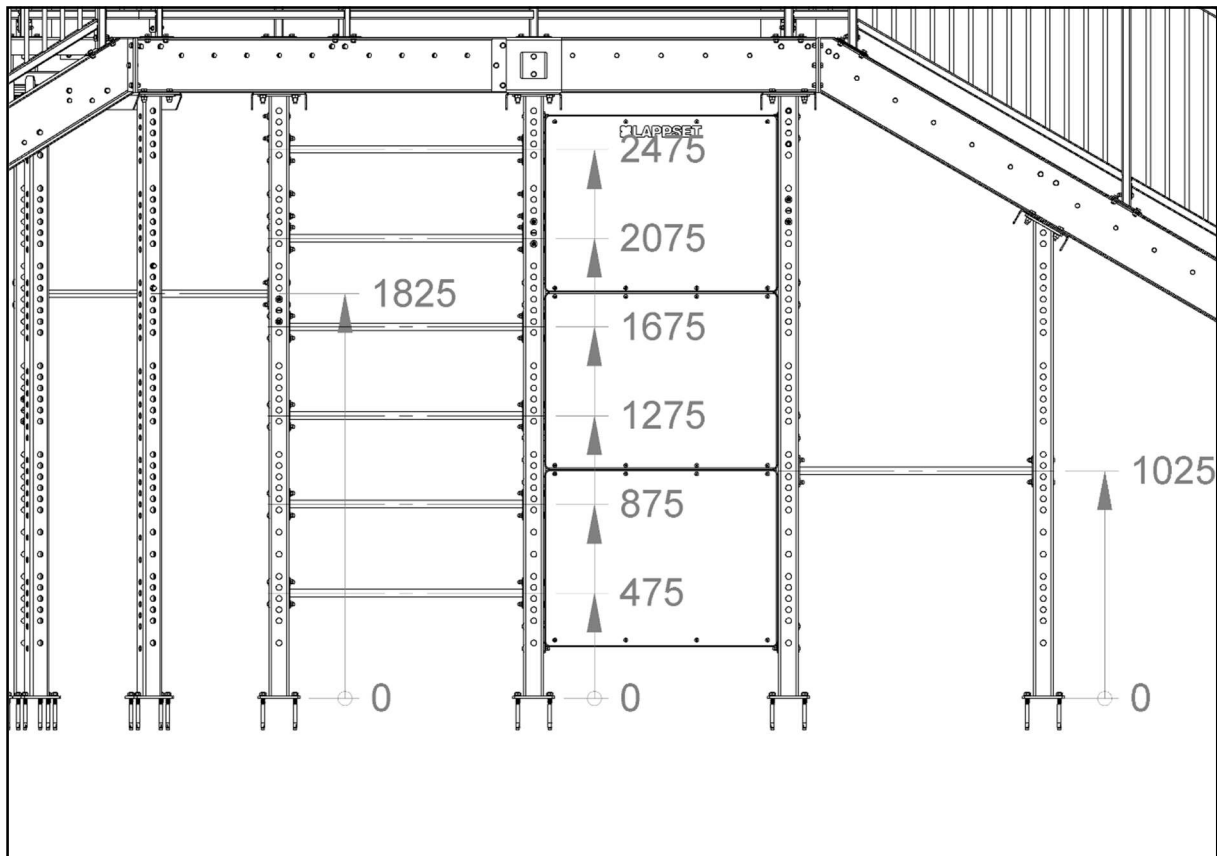
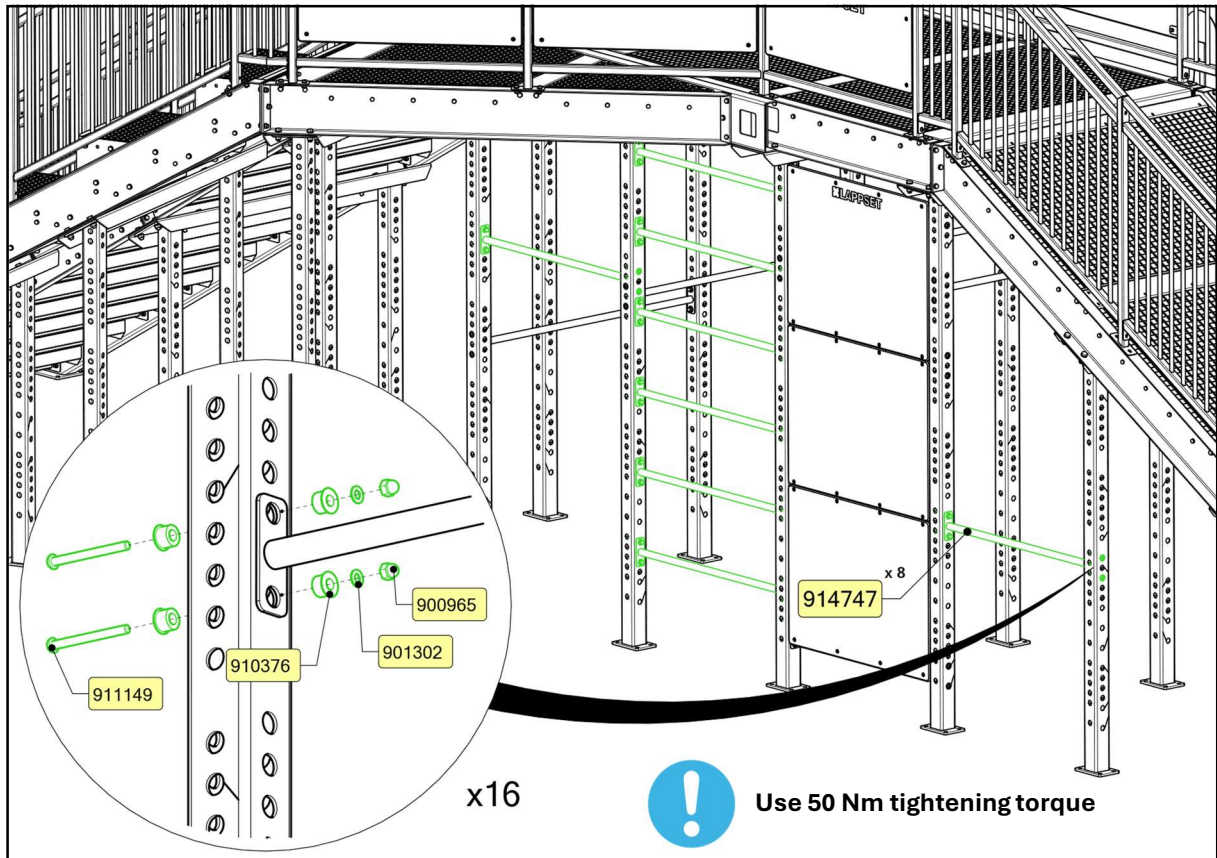

SISU FITNESS STAIRS

BARS-3 (3 PCS)

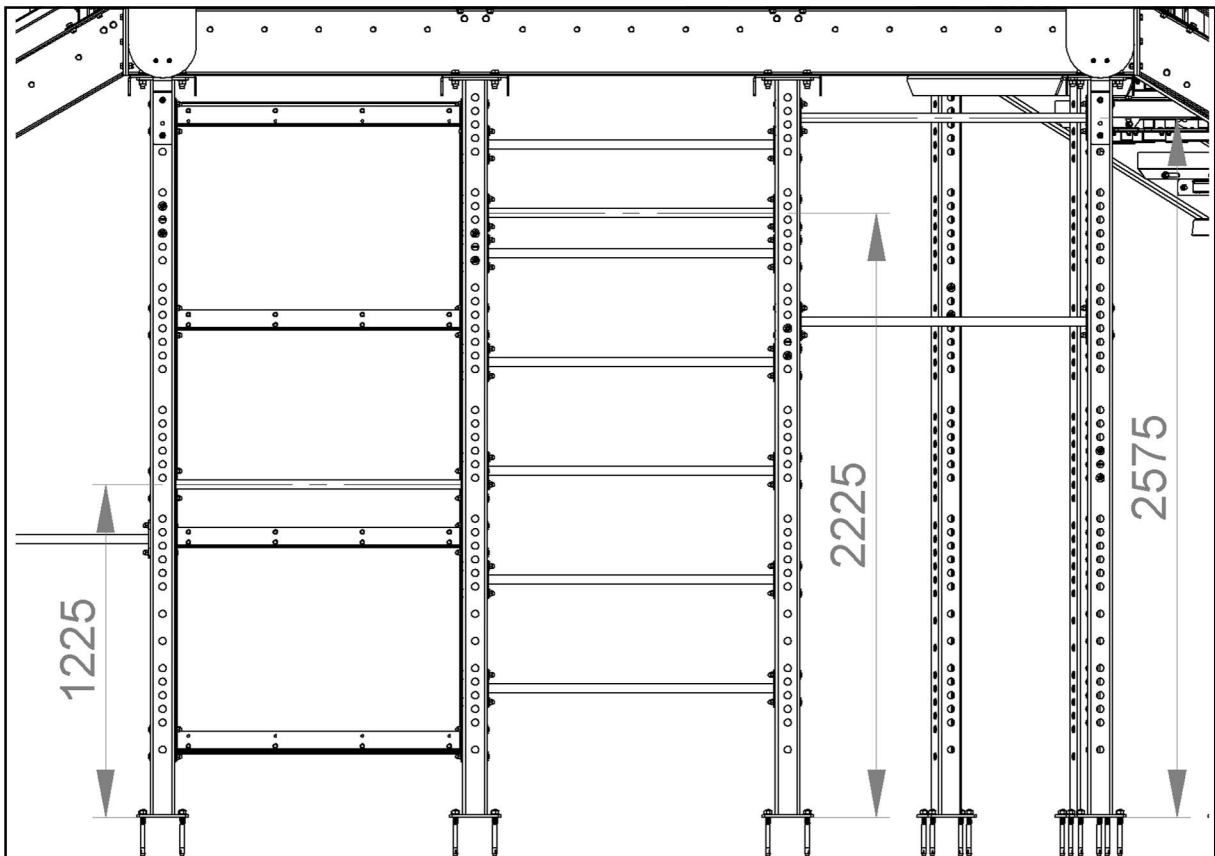
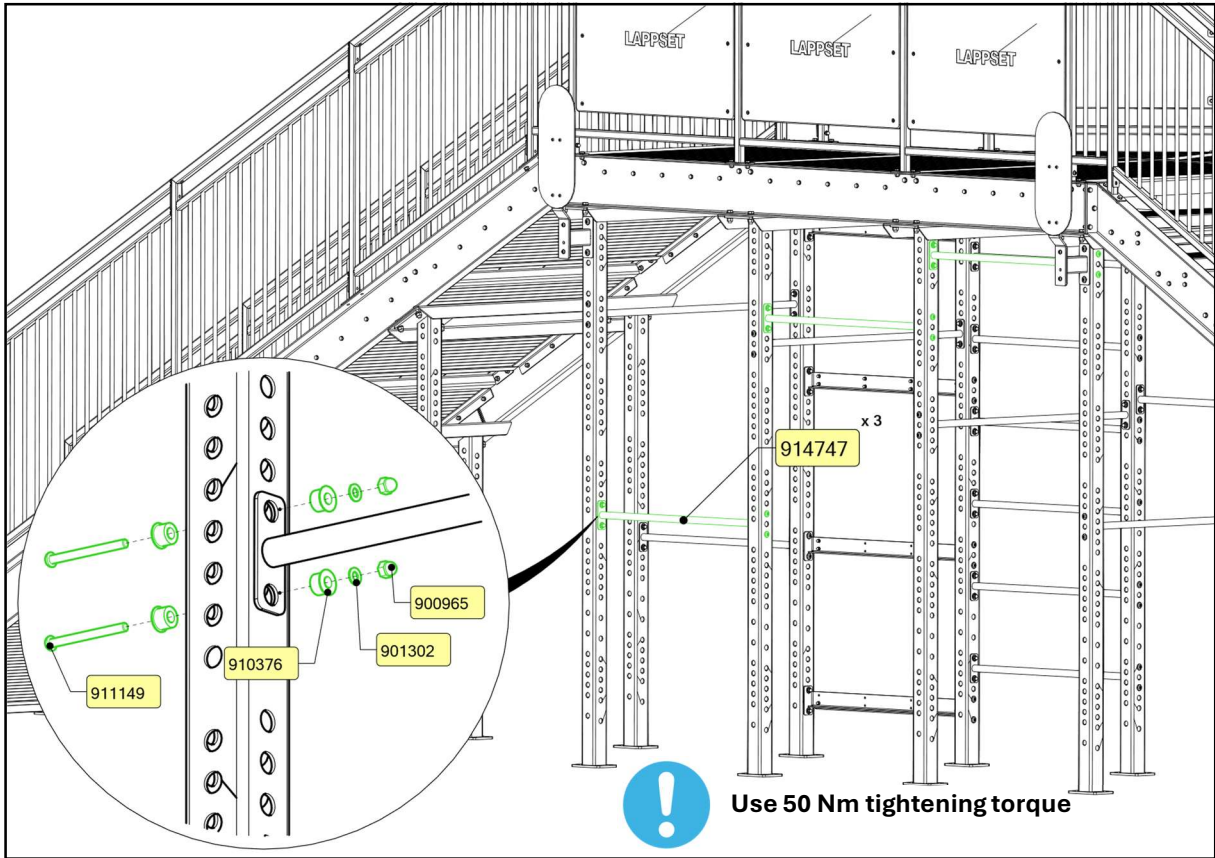

SISU FITNESS STAIRS

ROPE RINGS (6 PCS)

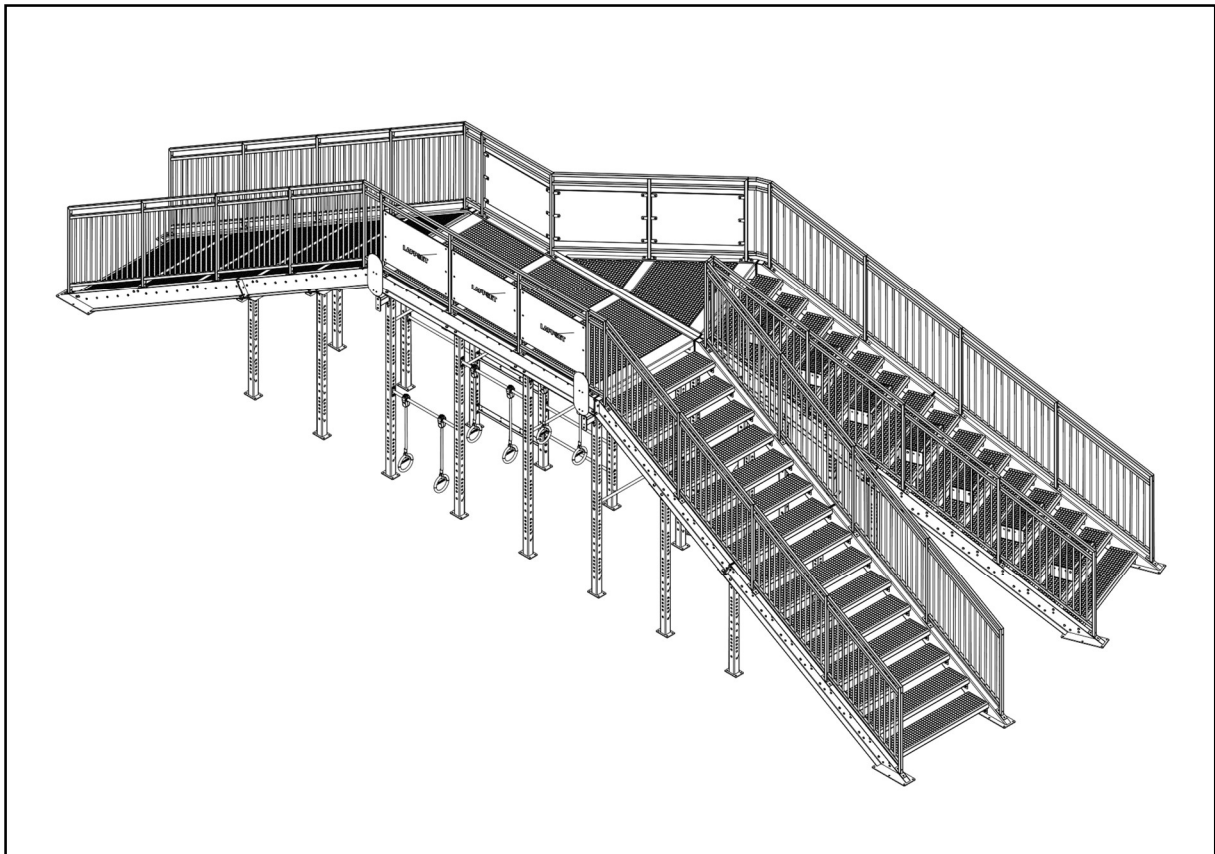
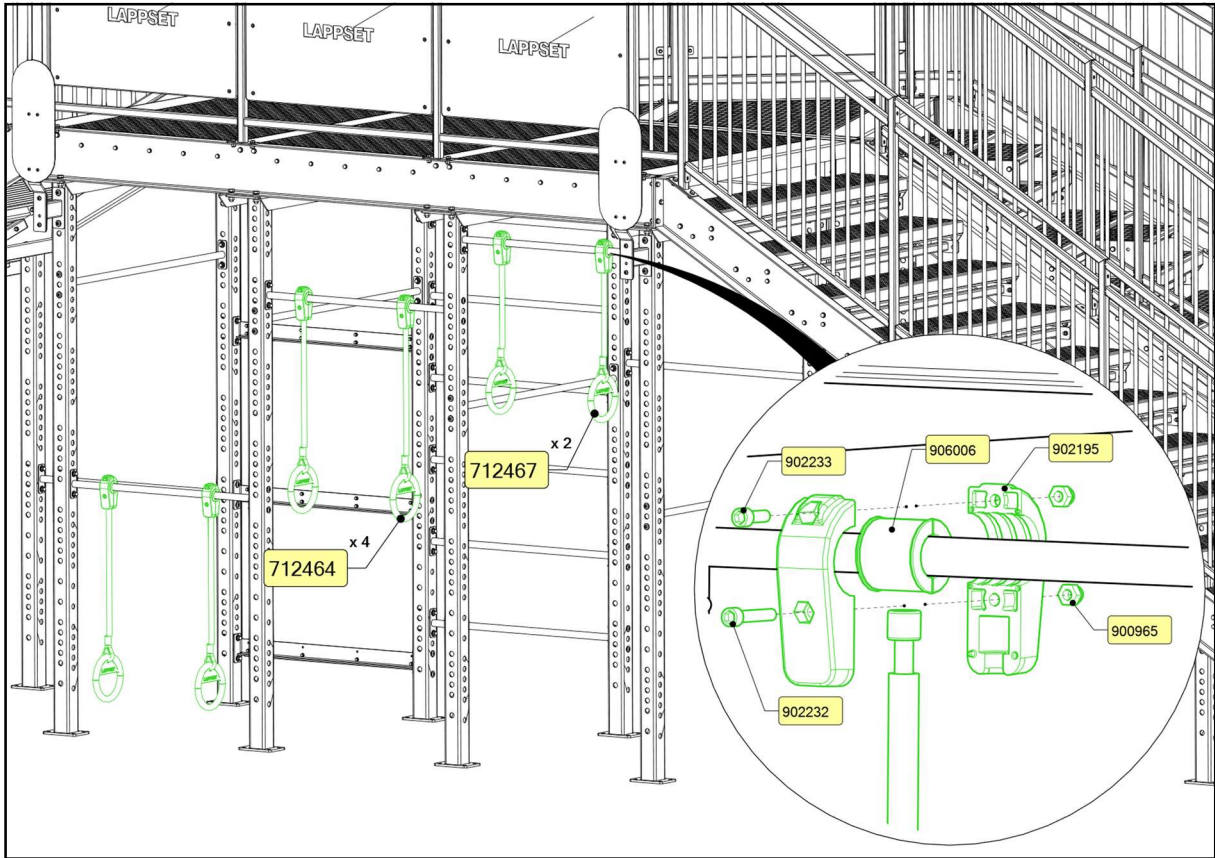

SISU FITNESS STAIRS

ANCHORS (124 PCS)

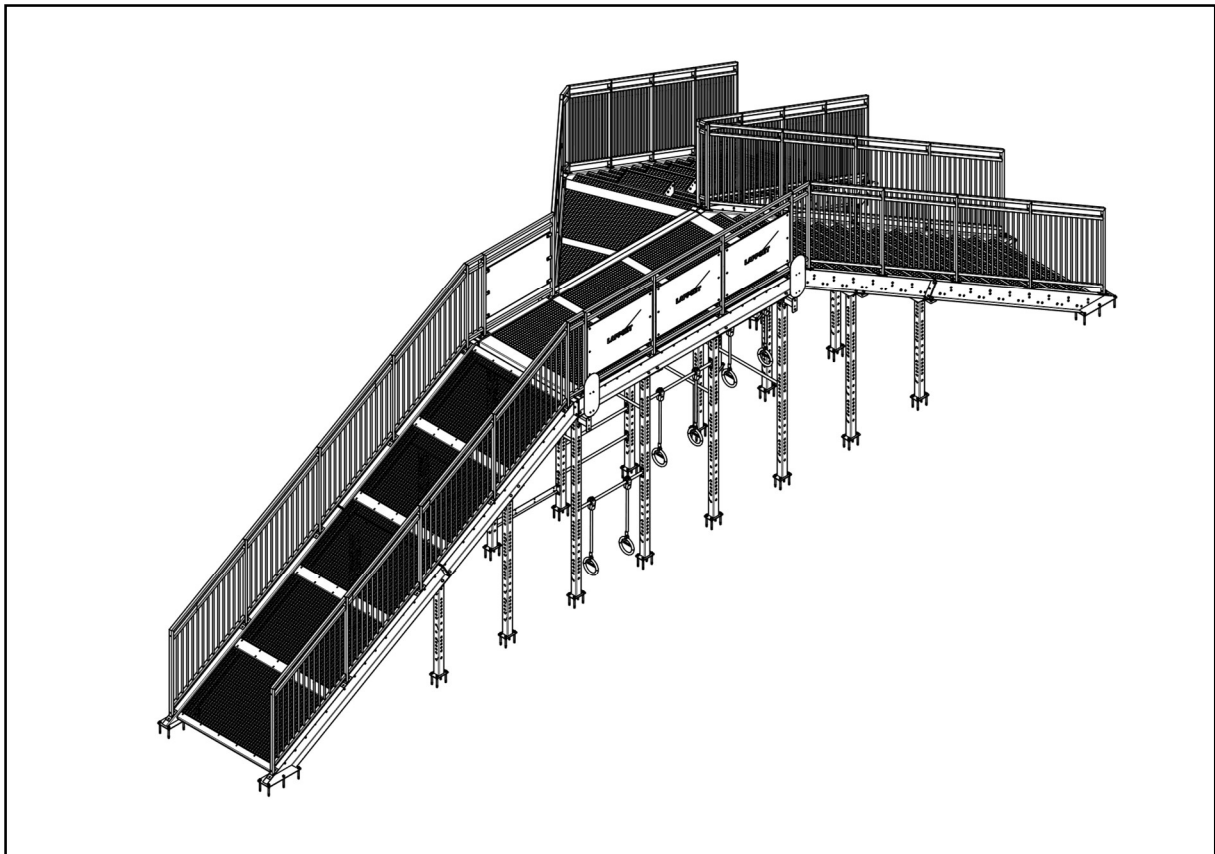
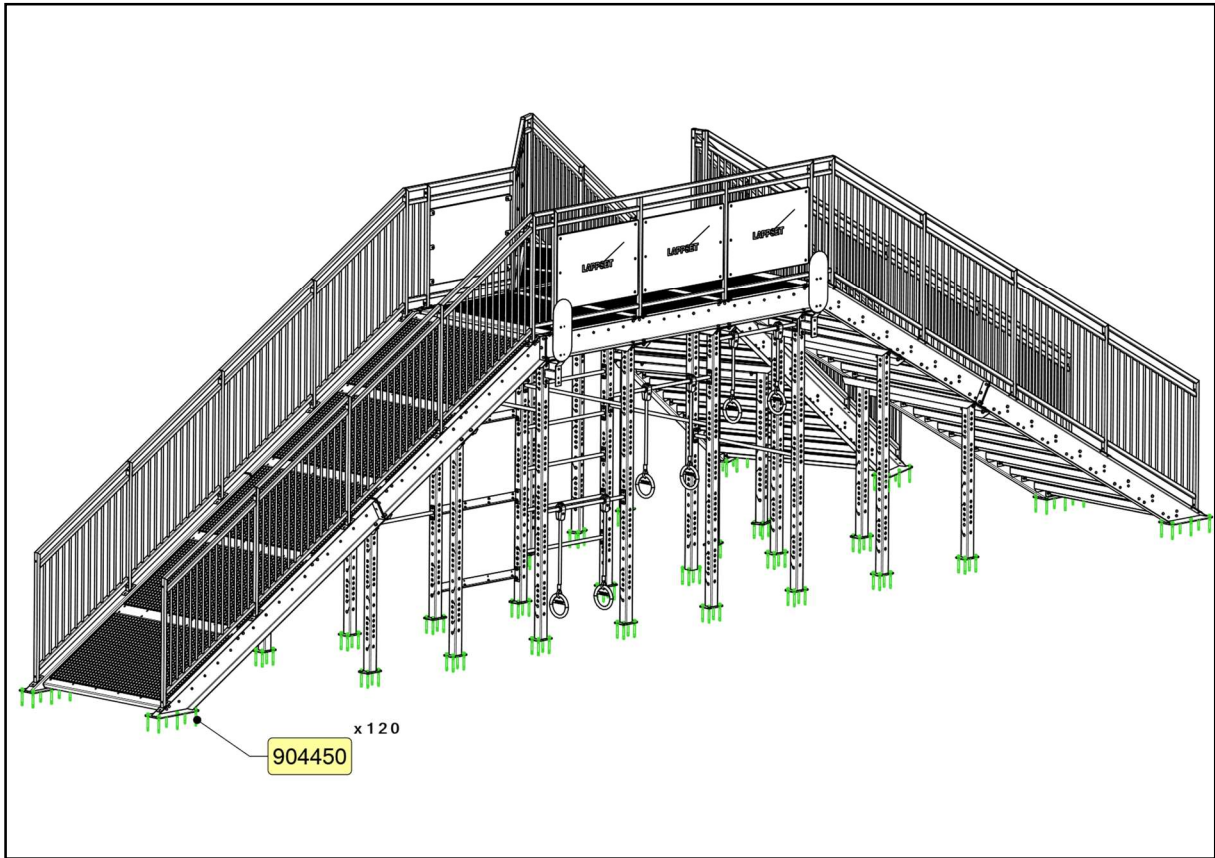

SISU FITNESS STAIRS

VERTICAL BAR (1 PC)

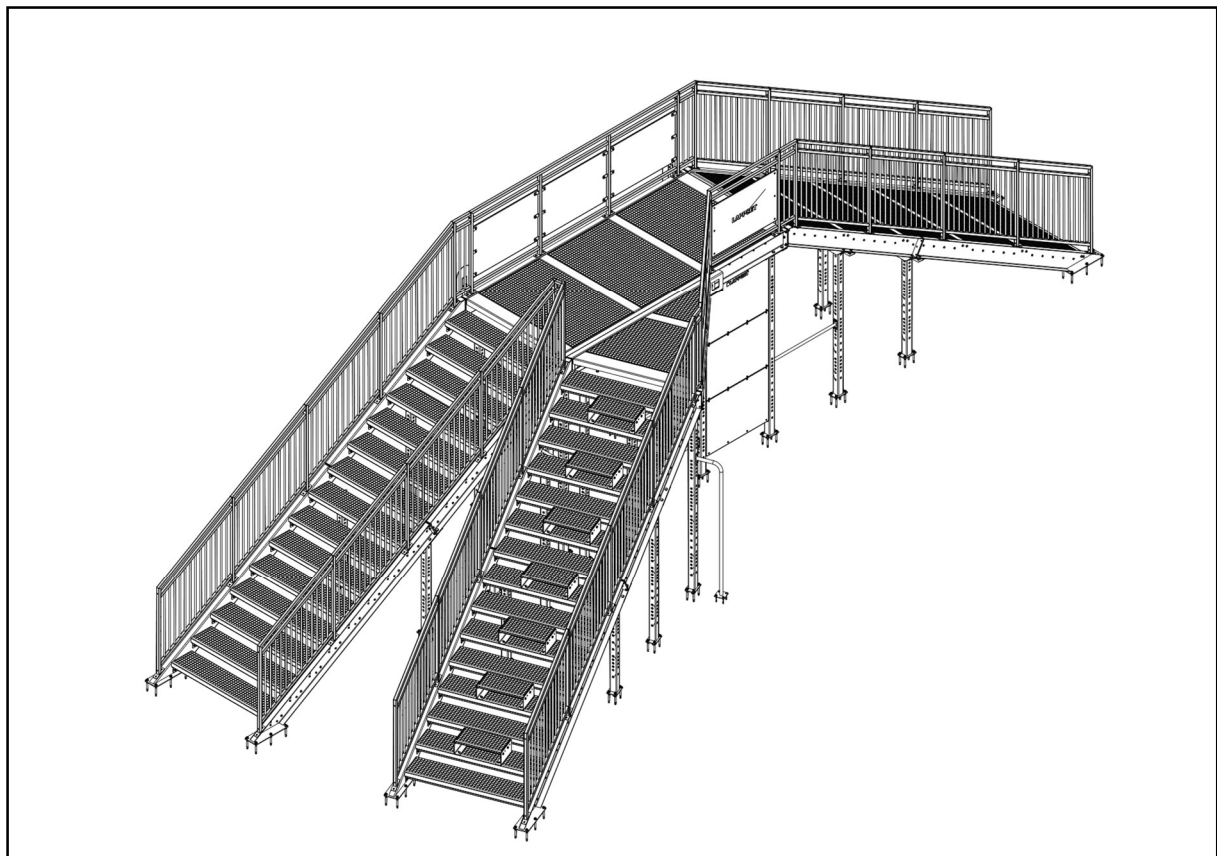
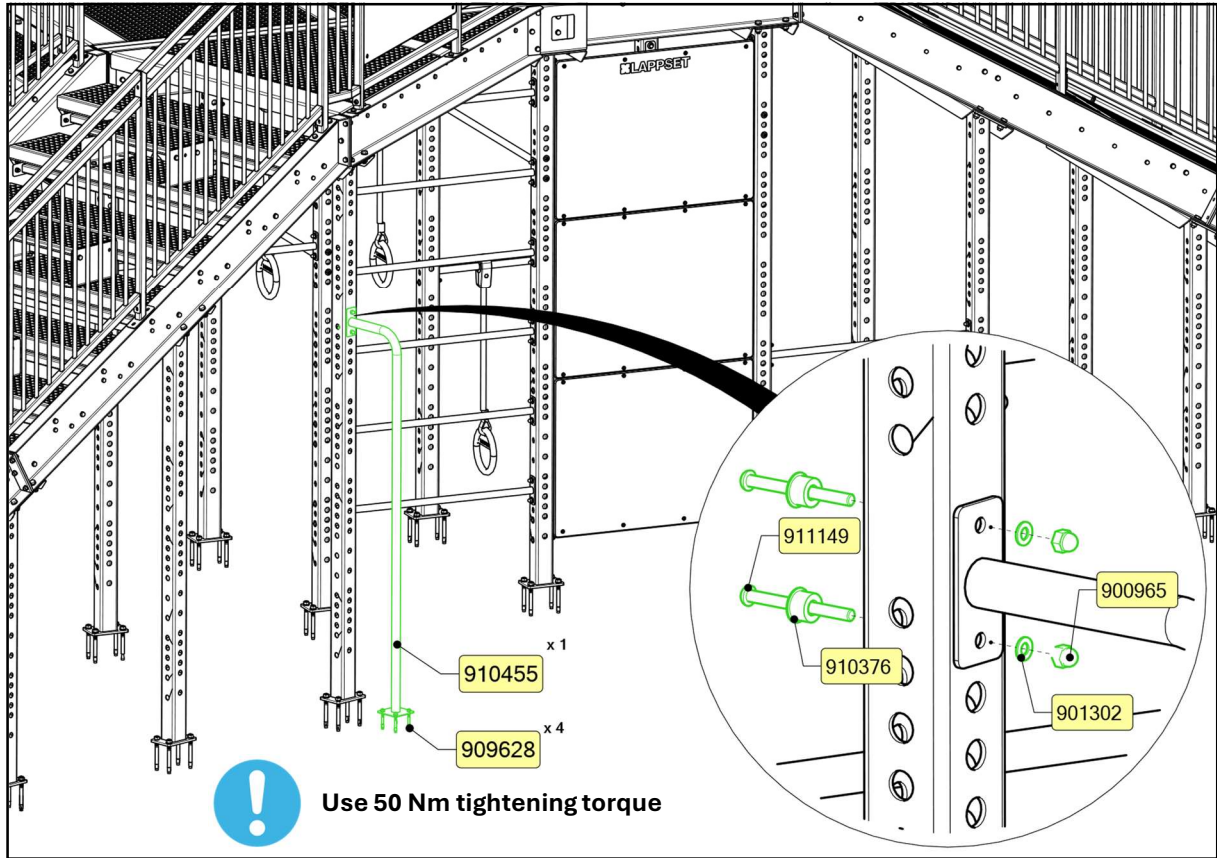

SISU FITNESS STAIRS

ABDOMINAL, BACK AND DIP MACHINE

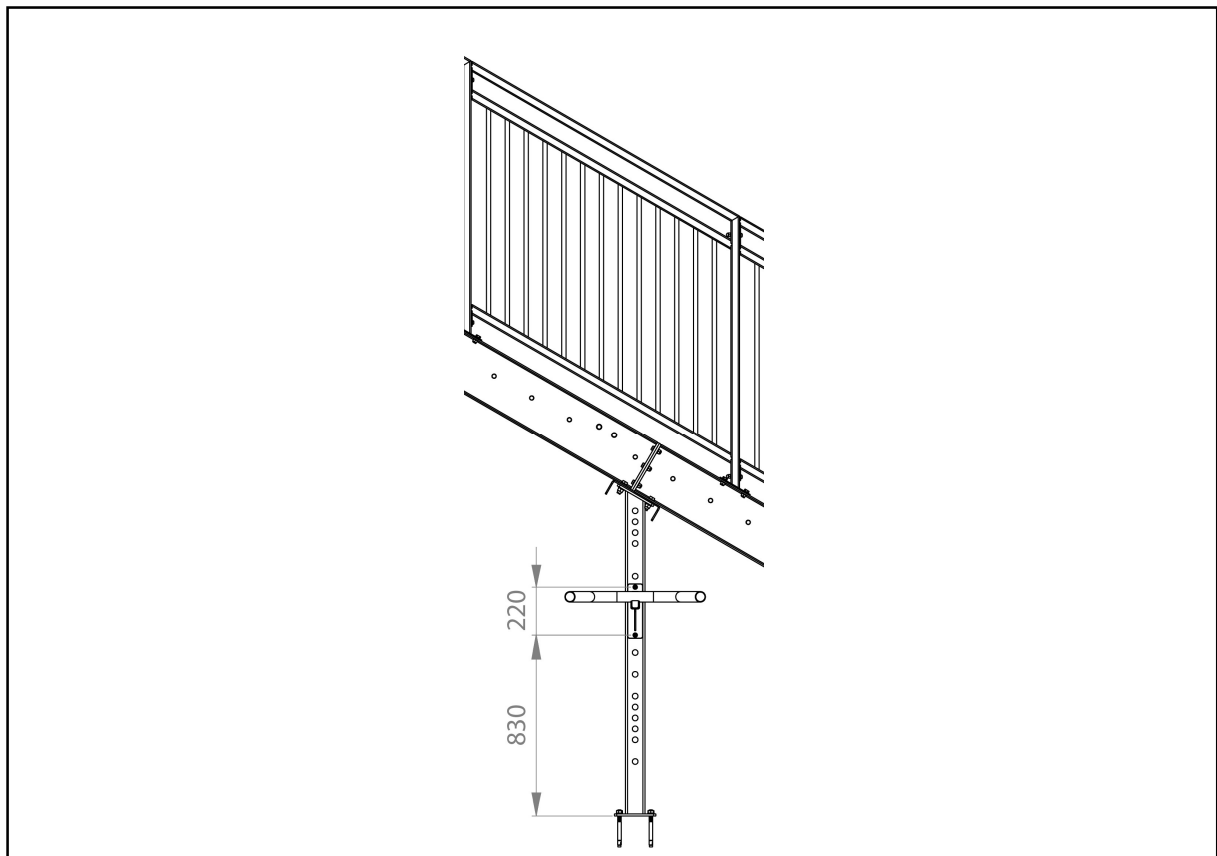
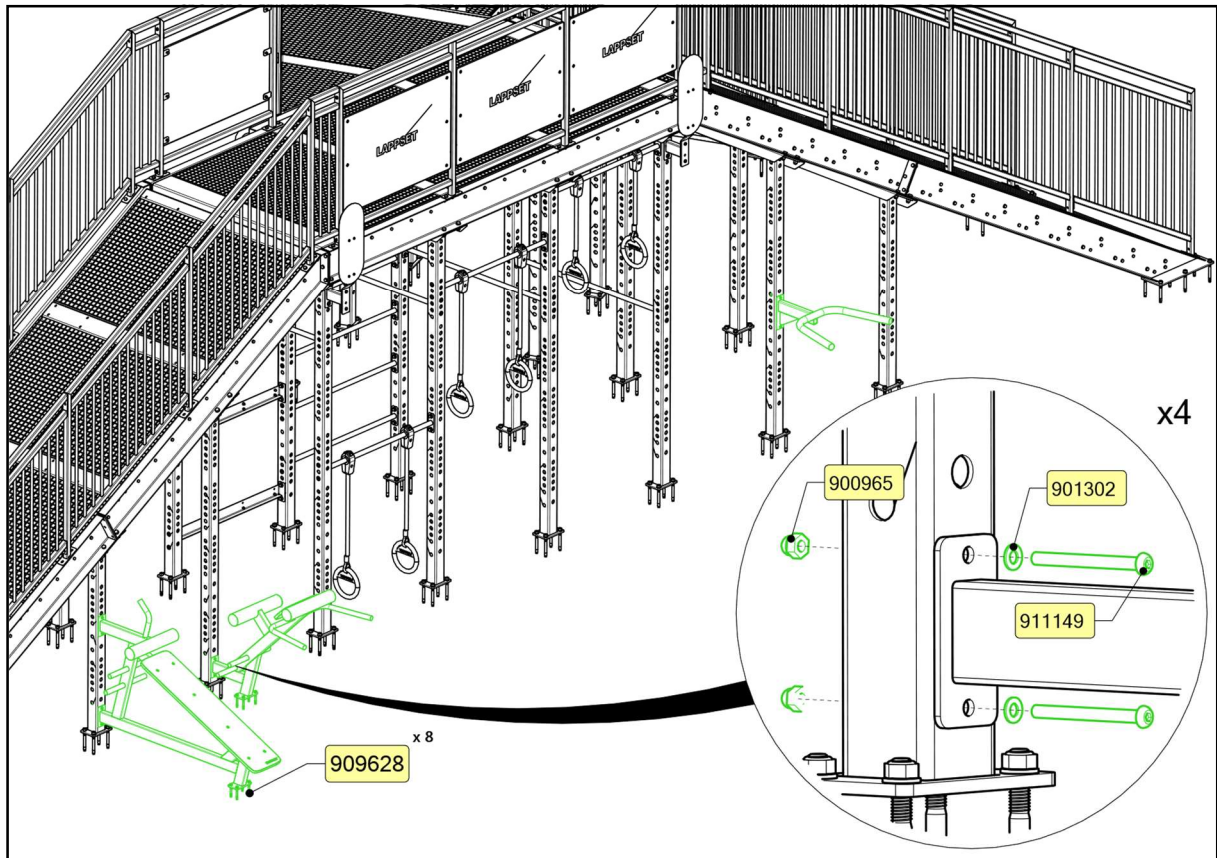

SISU FITNESS STAIRS

ABDOMINAL, BACK AND DIP MACHINE

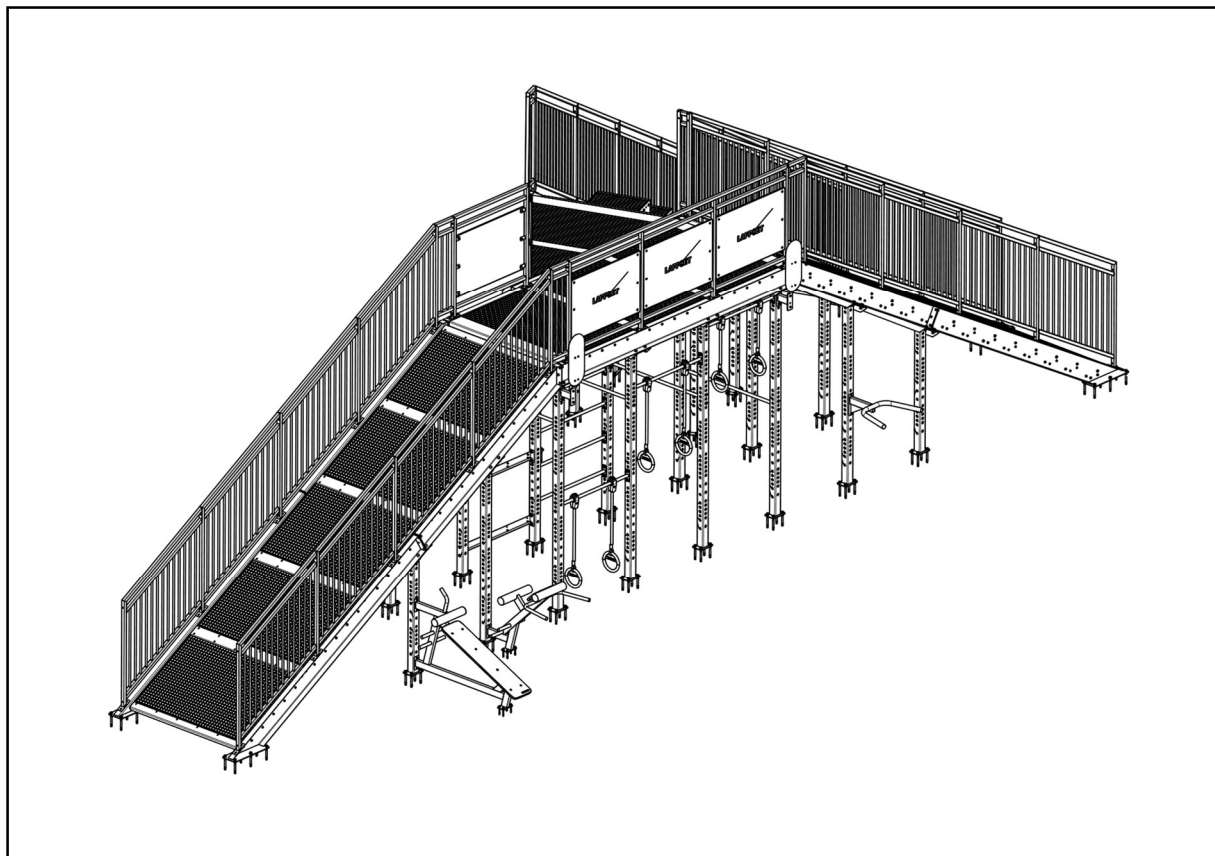
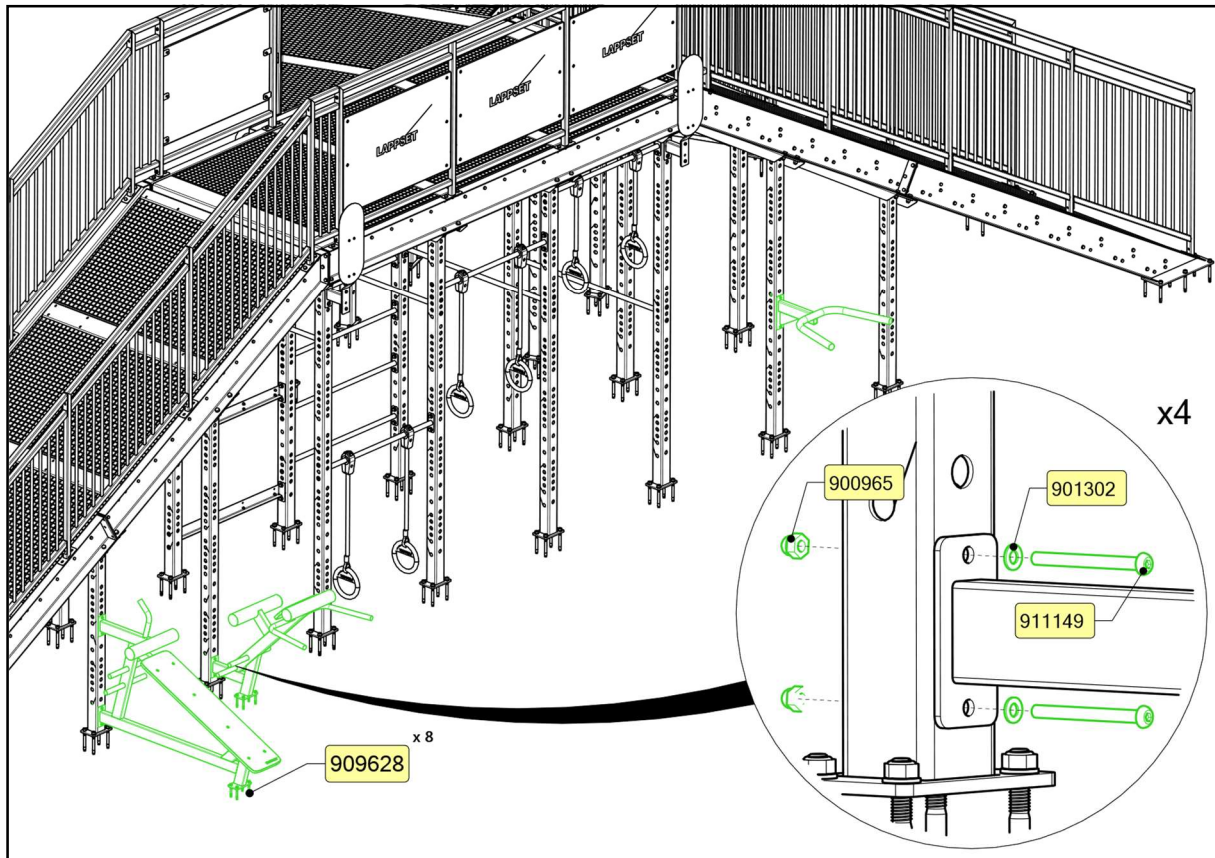

SISU FITNESS STAIRS

STAIR MARKS

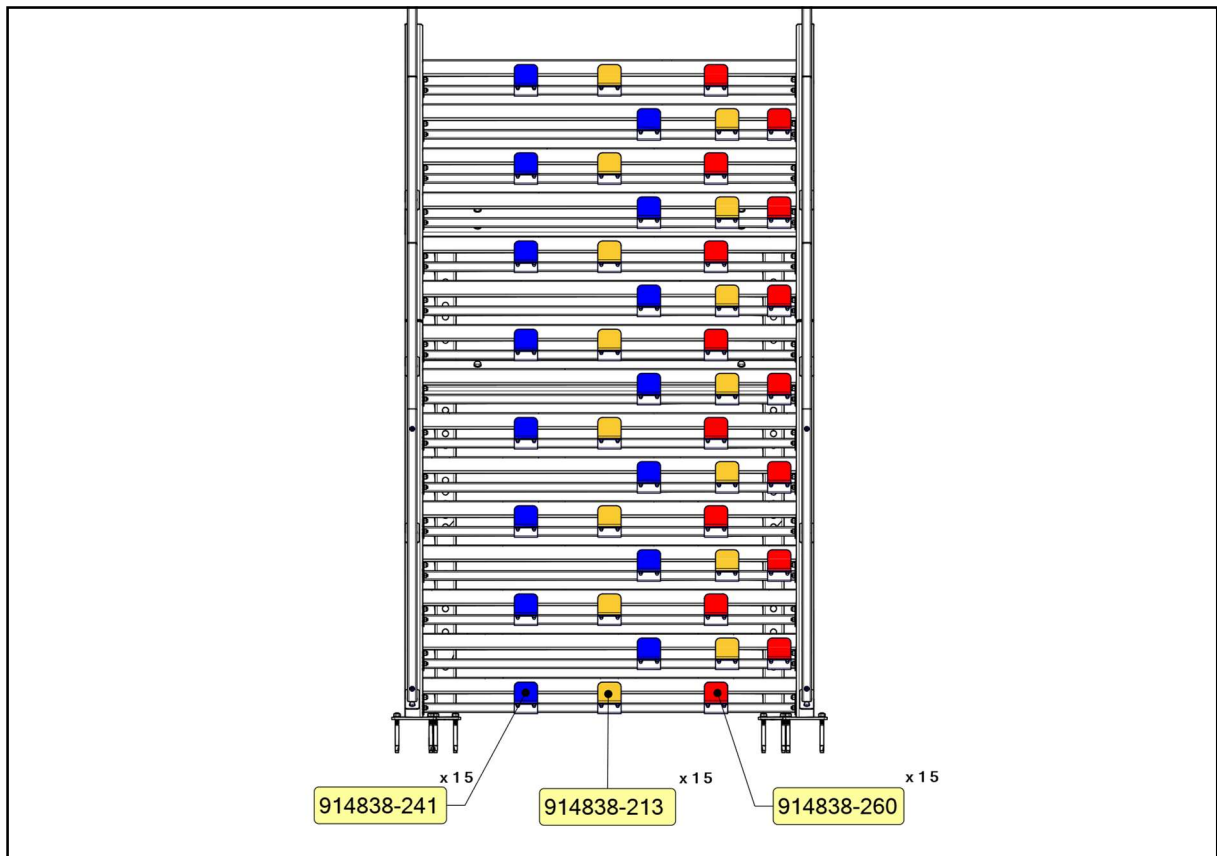
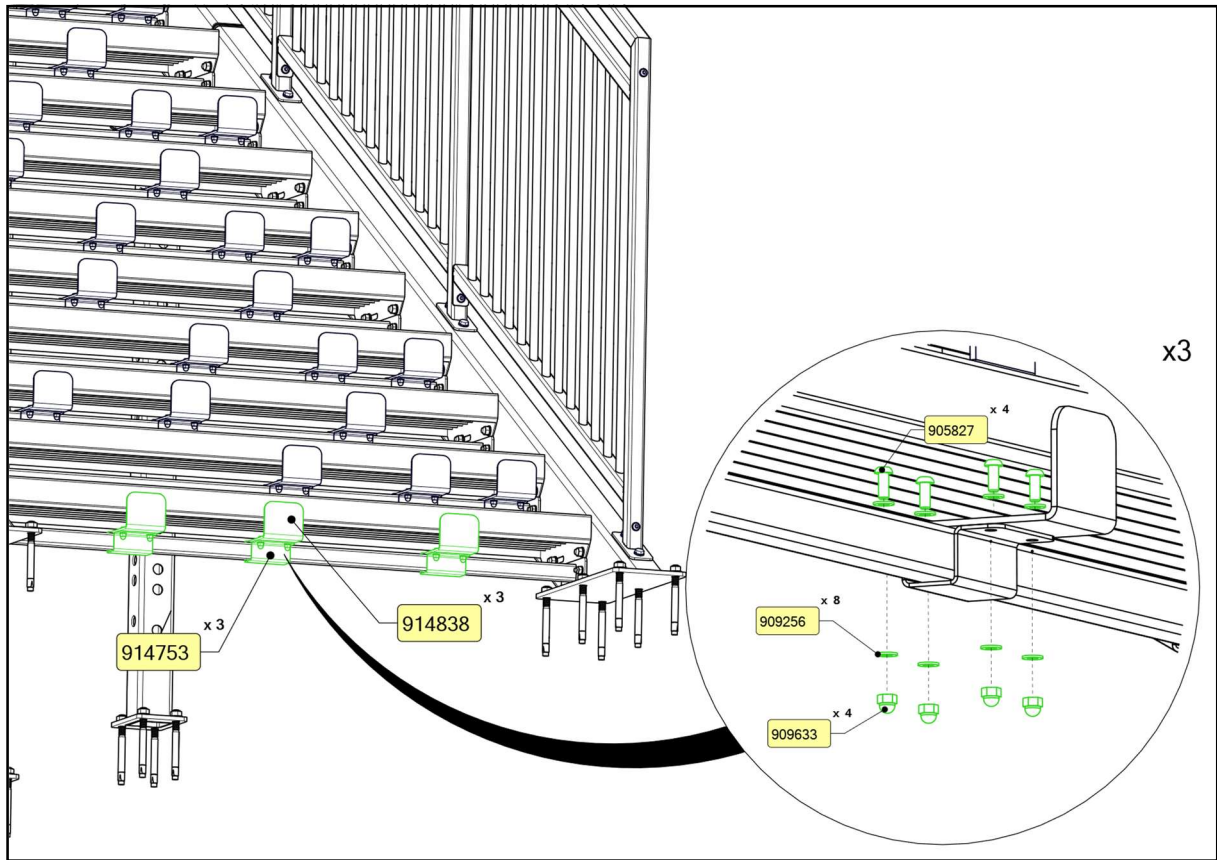

SISU FITNESS STAIRS

COUNTER

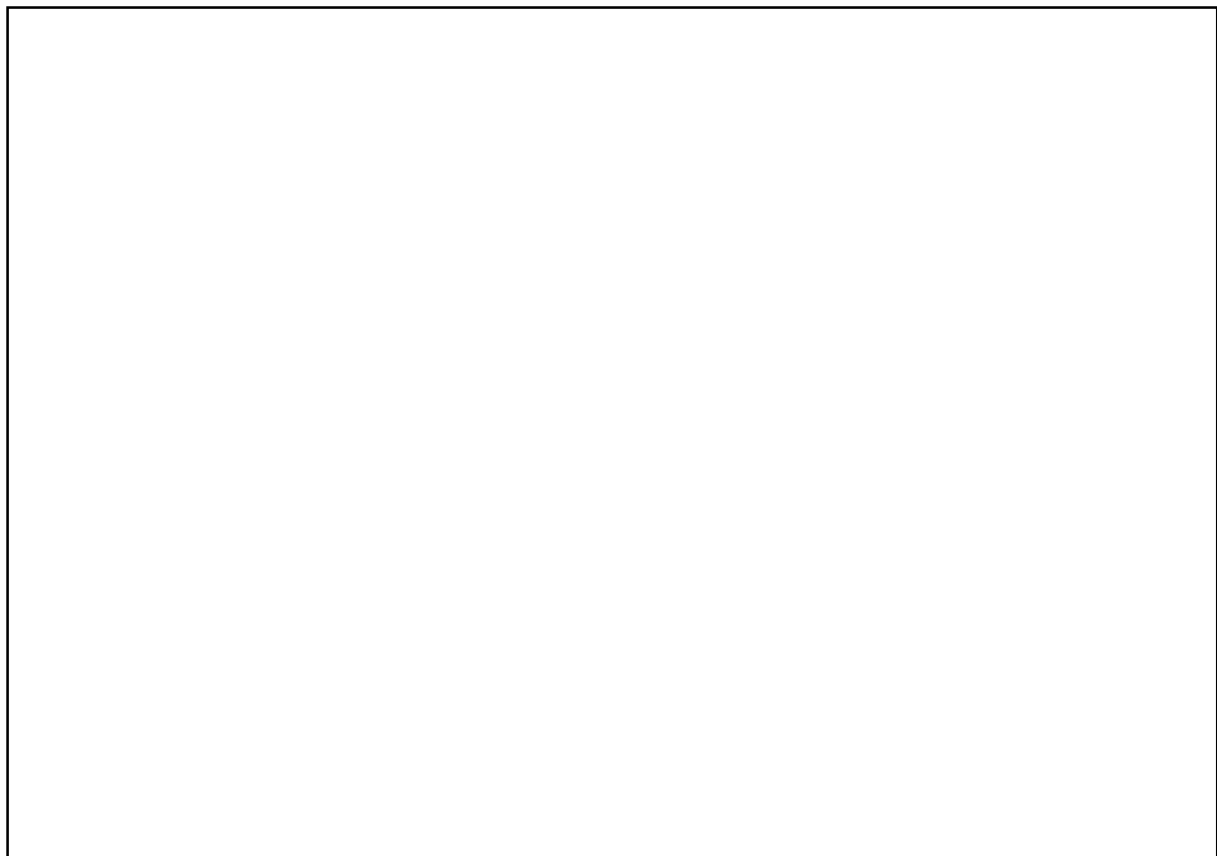
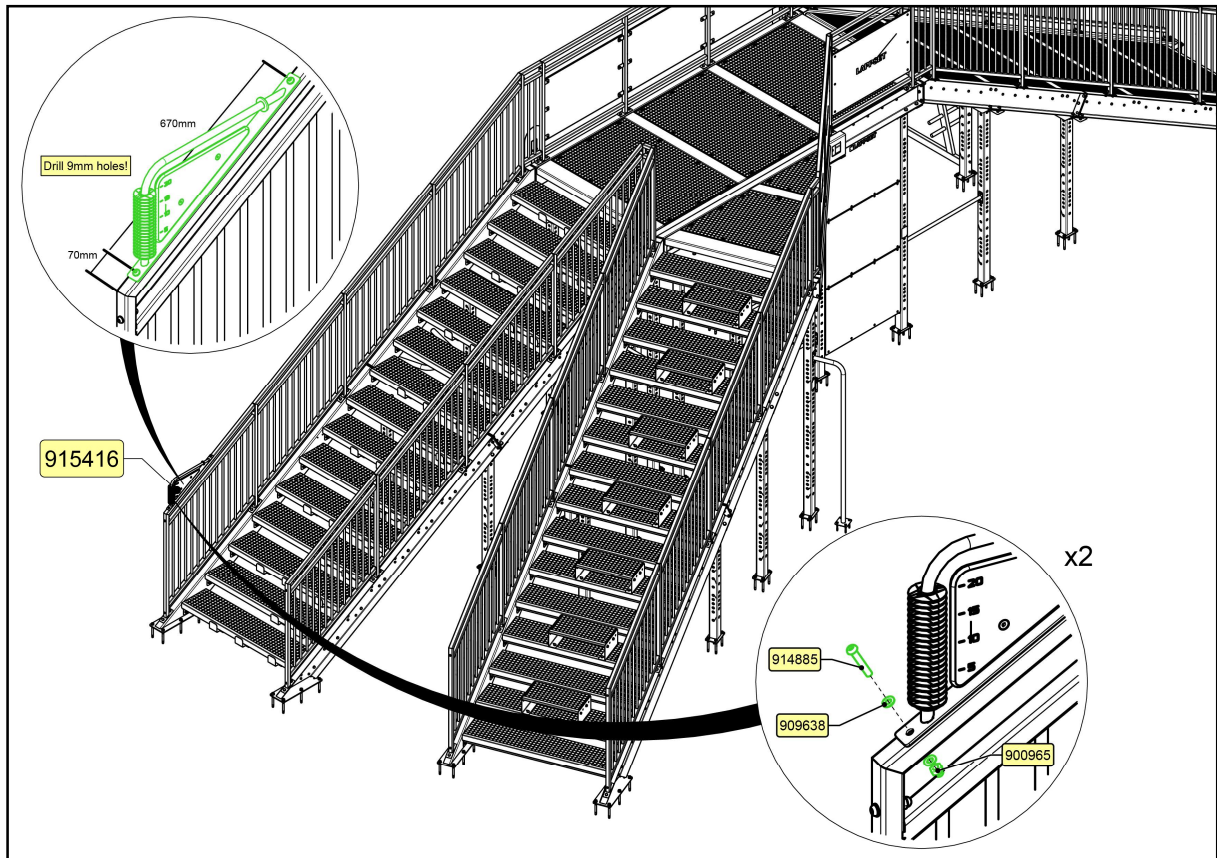

SISU FITNESS STAIRS

SIGNS

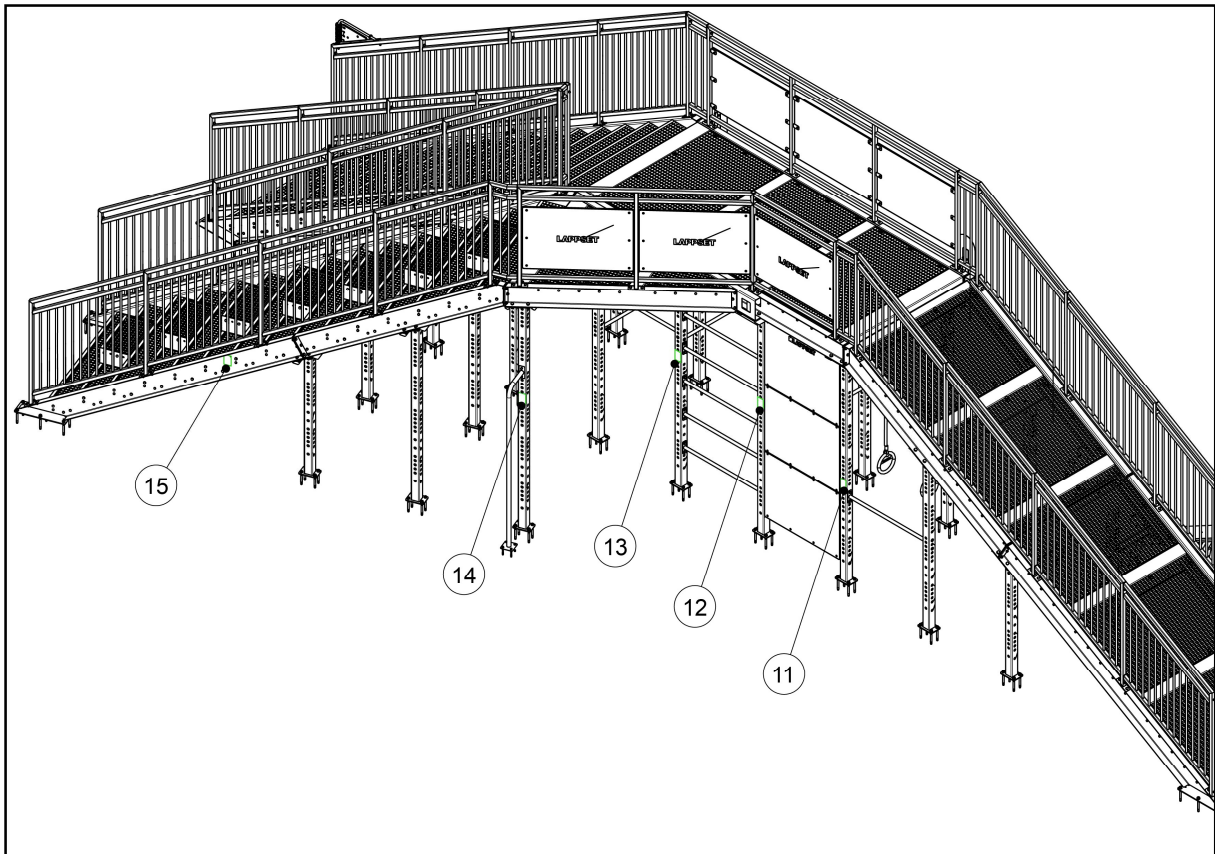
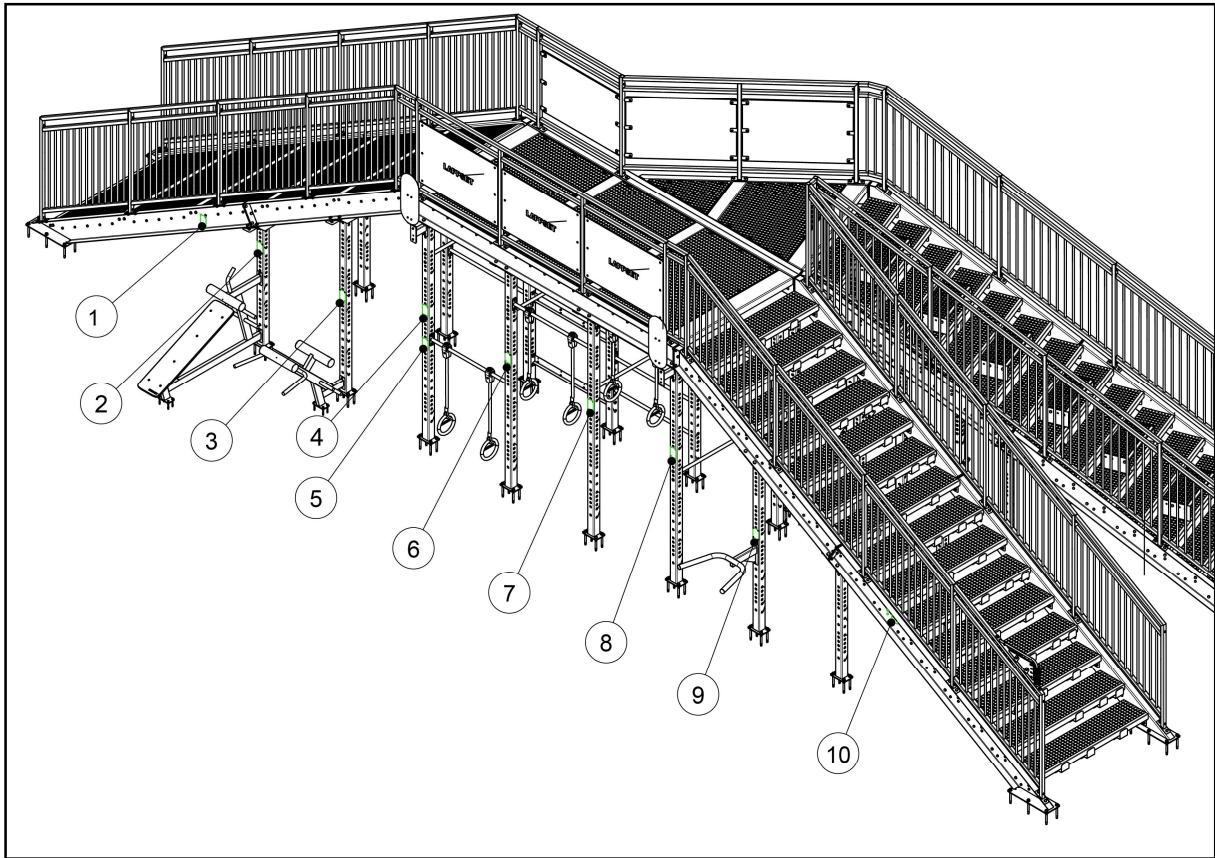

SISU FITNESS STAIRS

SIGN 1

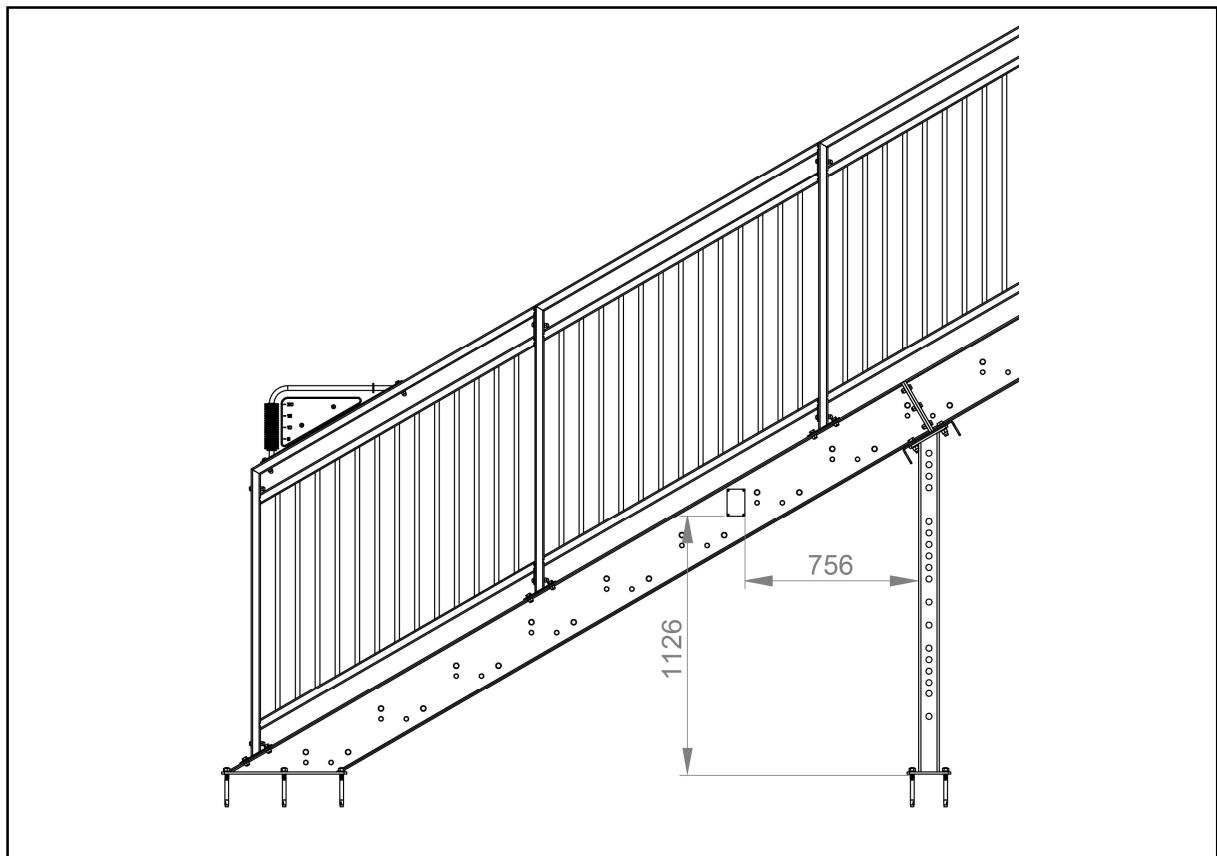
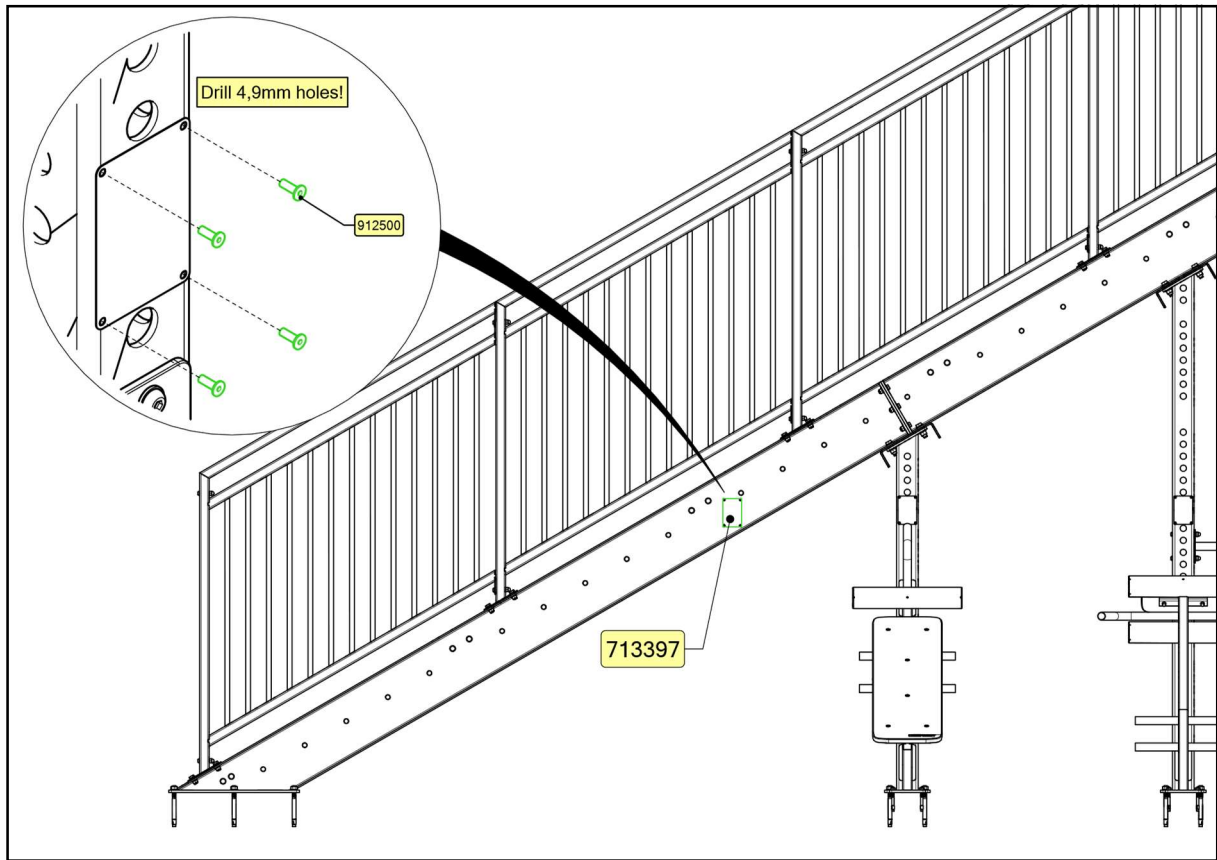

SISU FITNESS STAIRS

SIGN 2

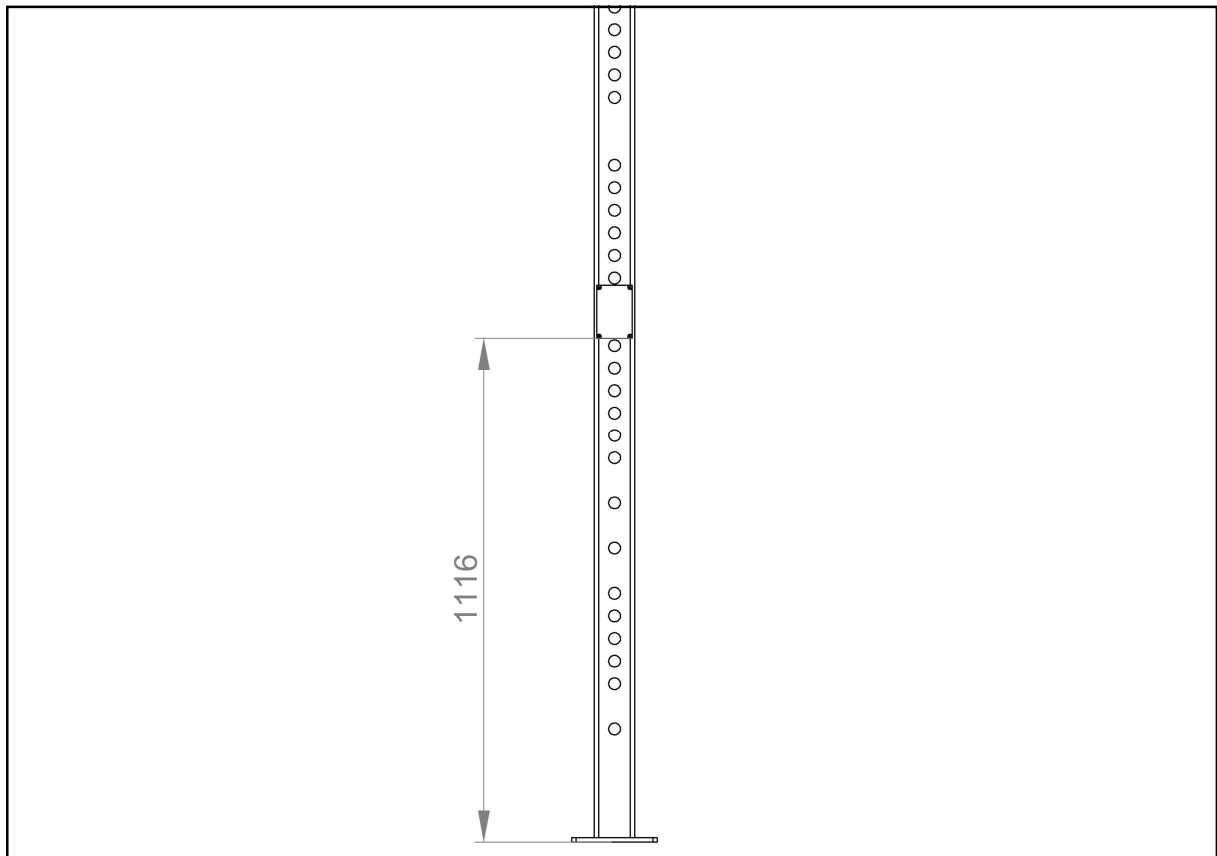
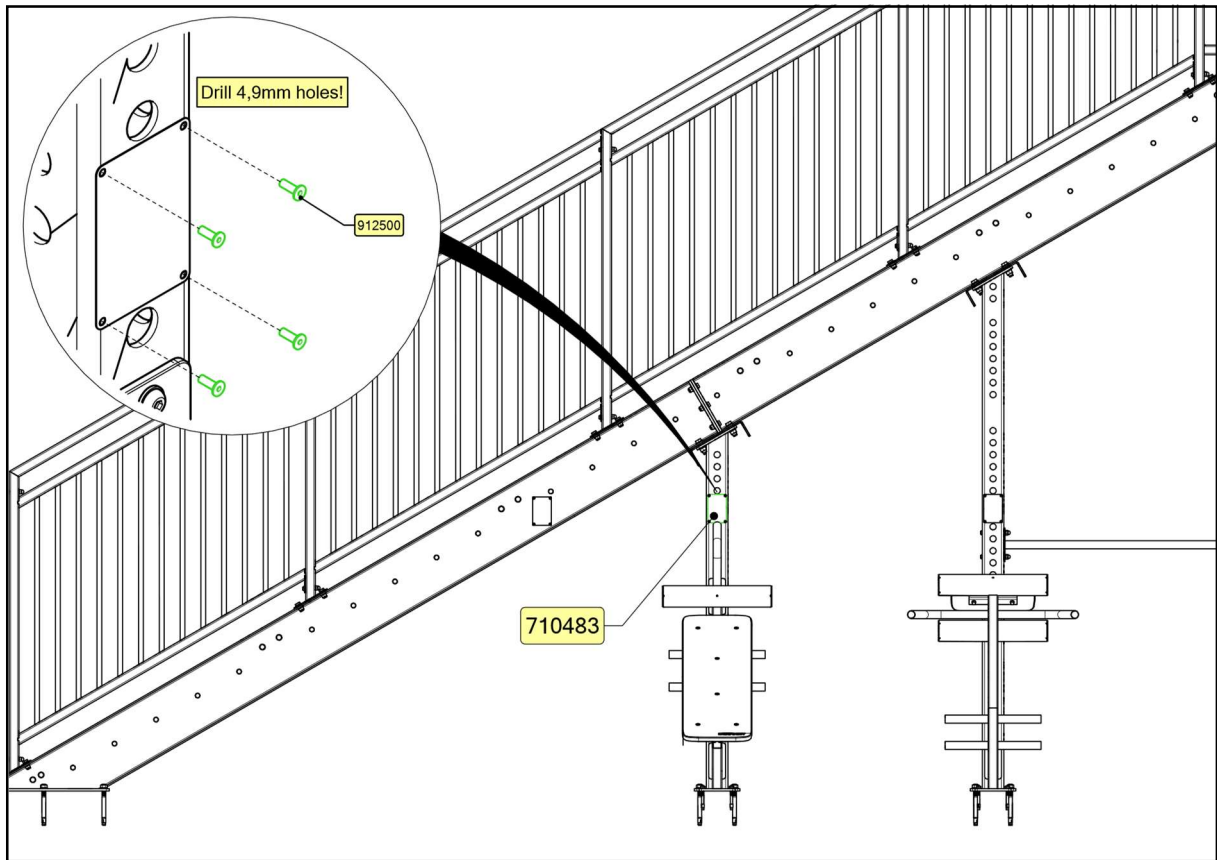

SISU FITNESS STAIRS

SIGN 3

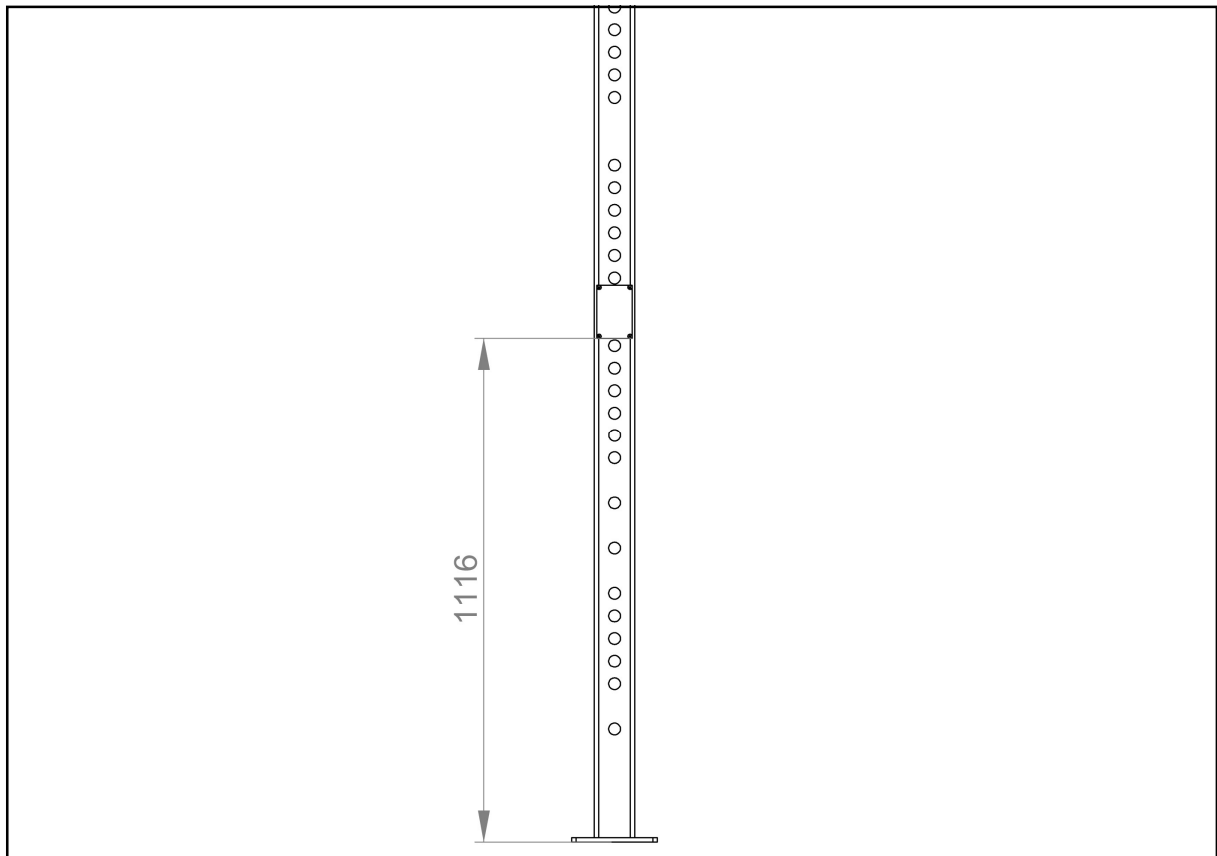
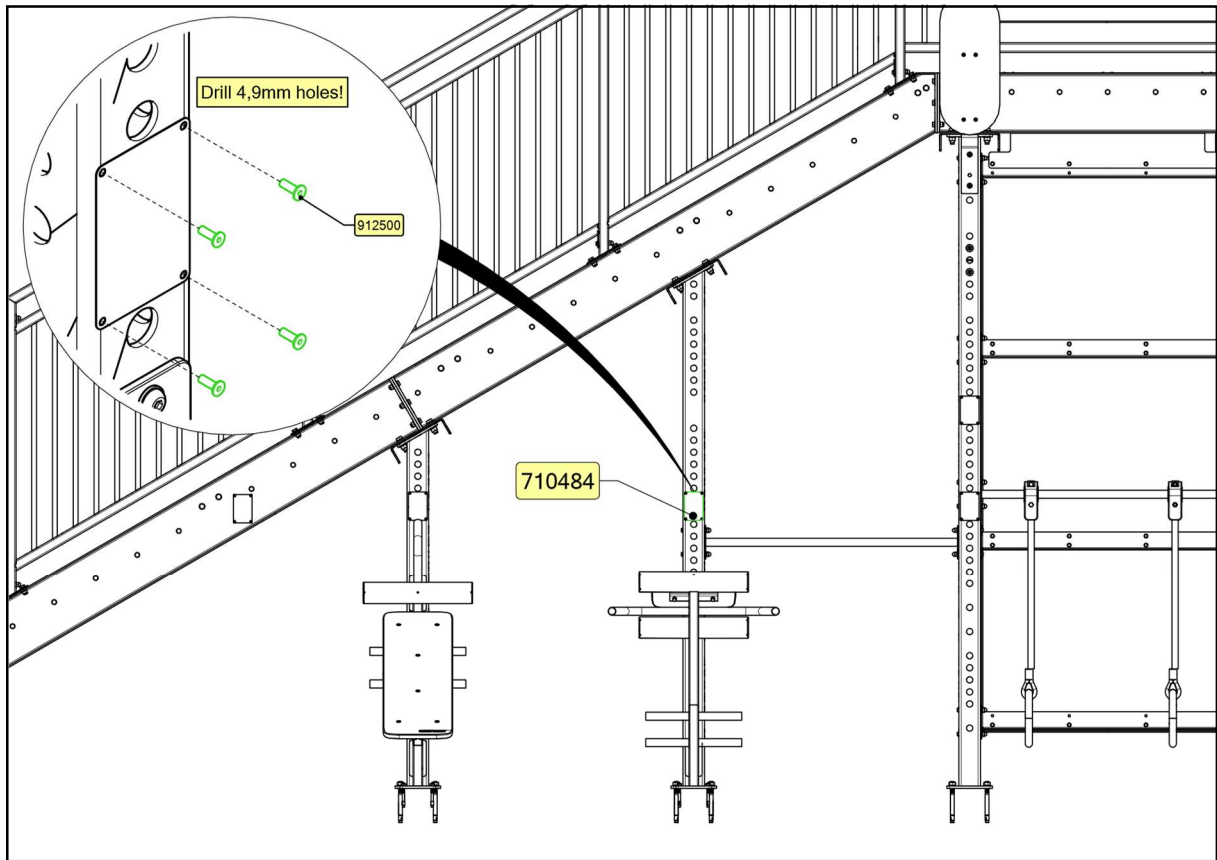

SISU FITNESS STAIRS

SIGN 4-5

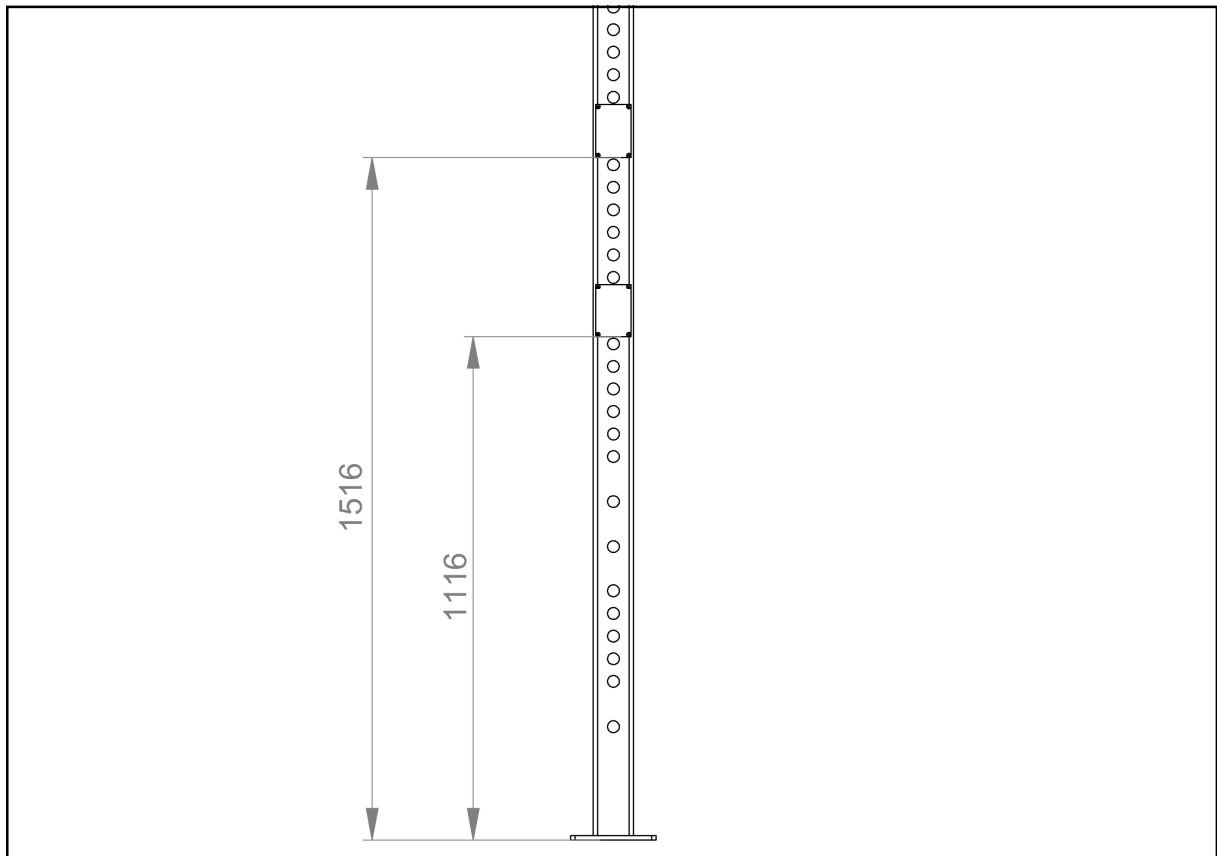
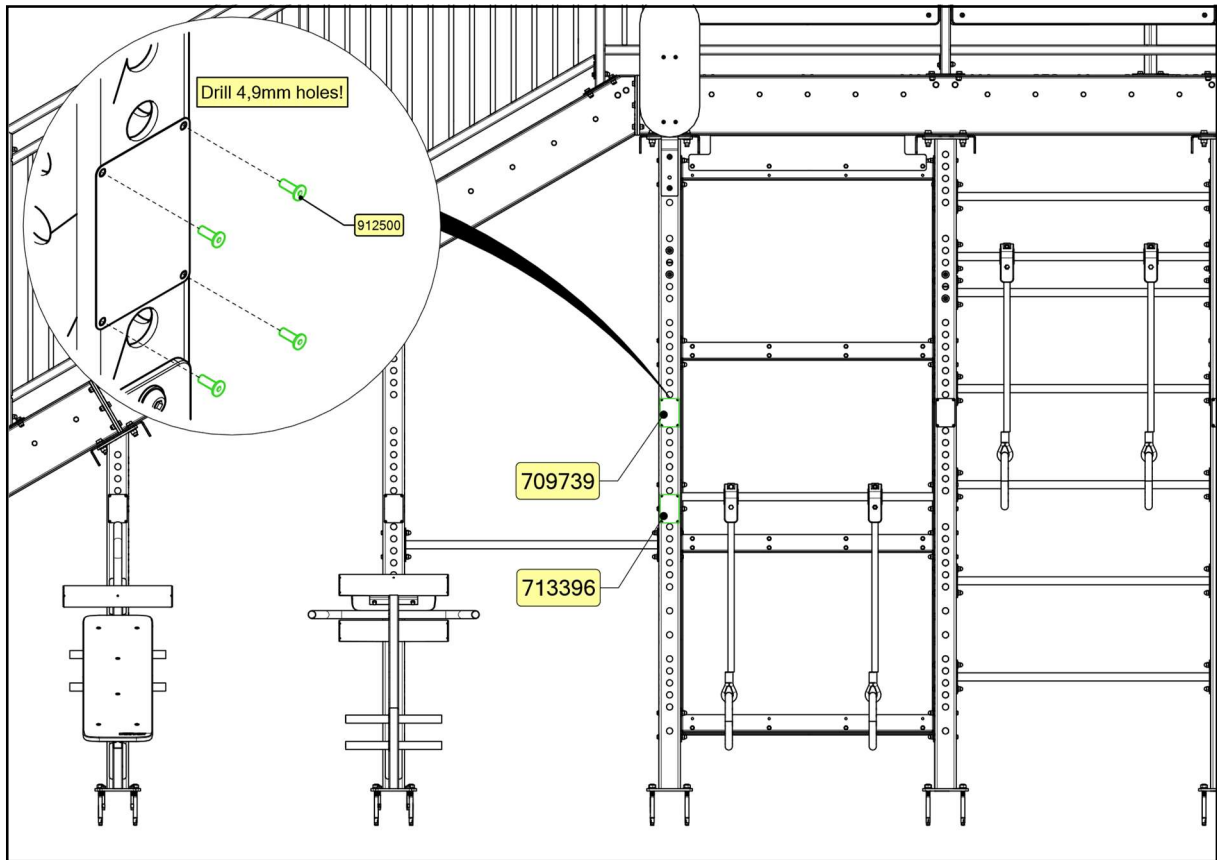

SISU FITNESS STAIRS

SIGN 6

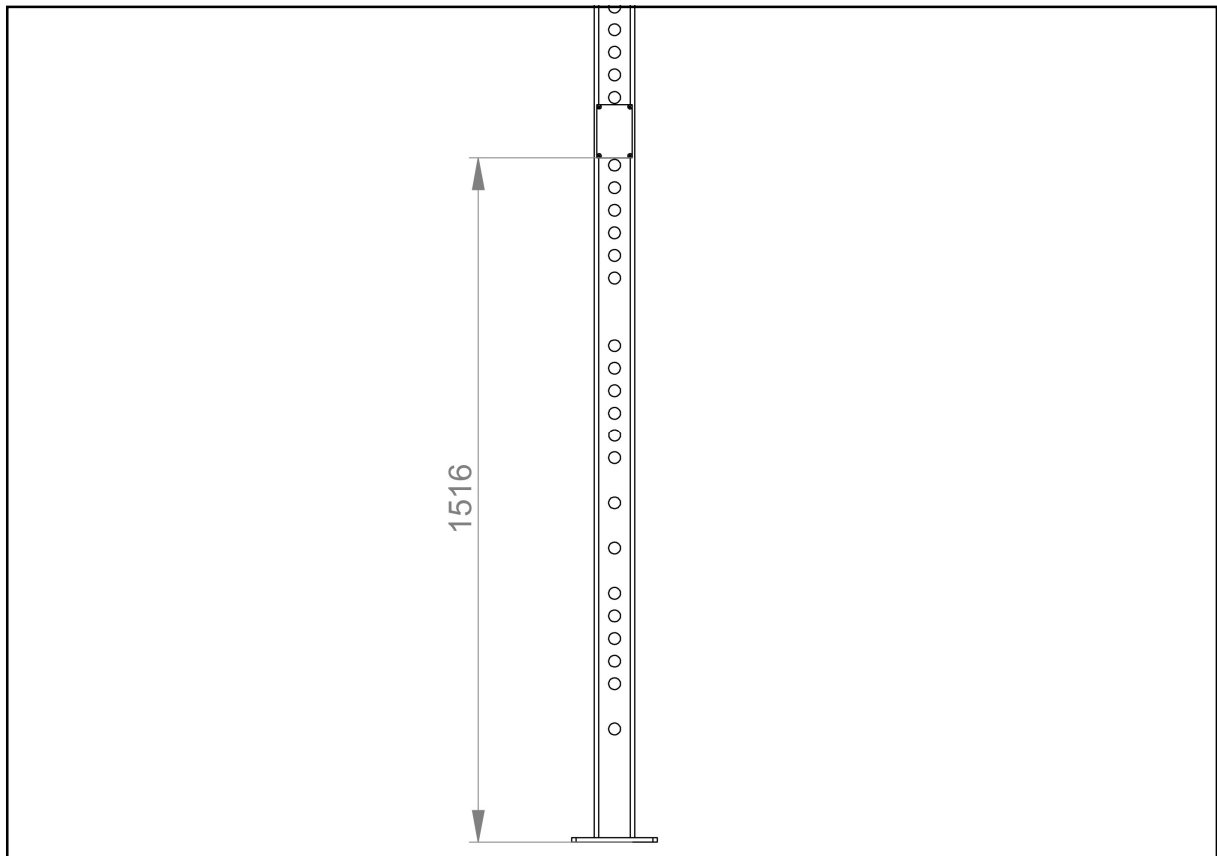
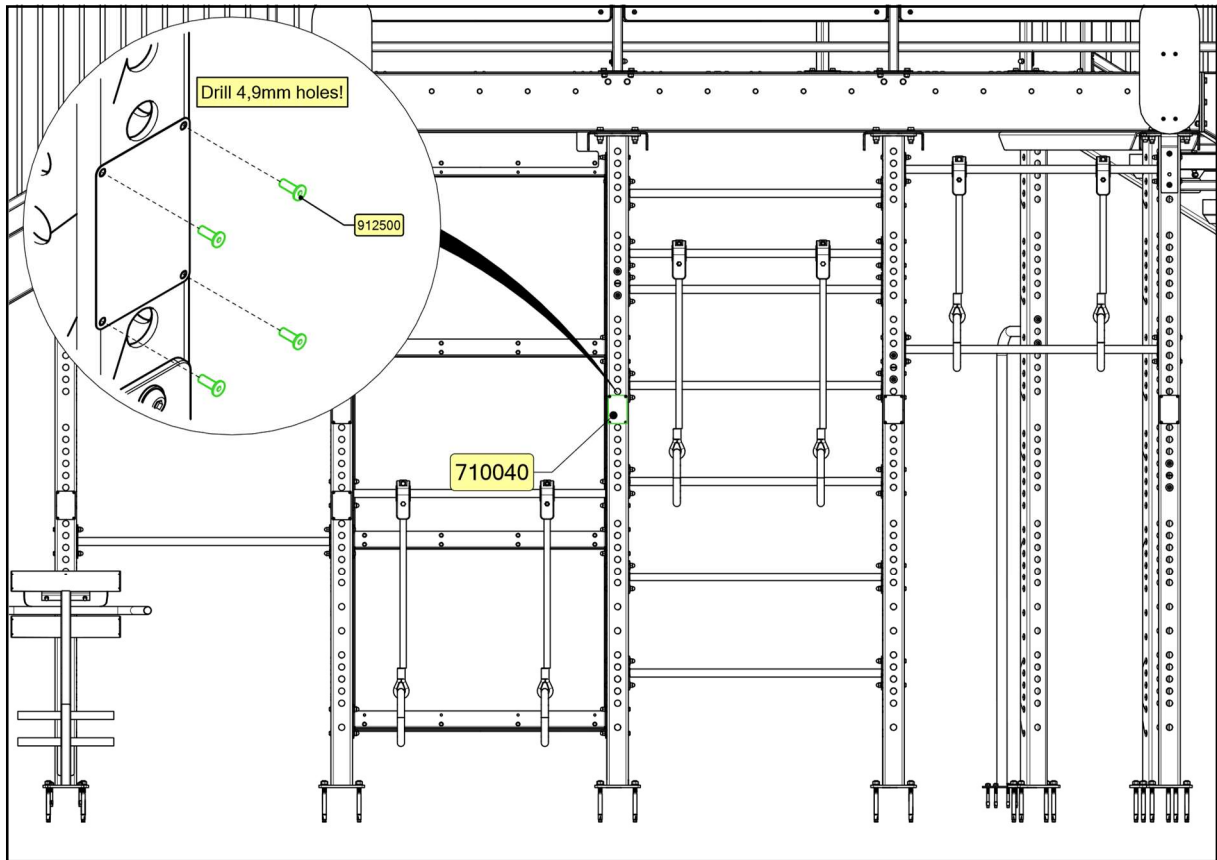

SISU FITNESS STAIRS

SIGN 7

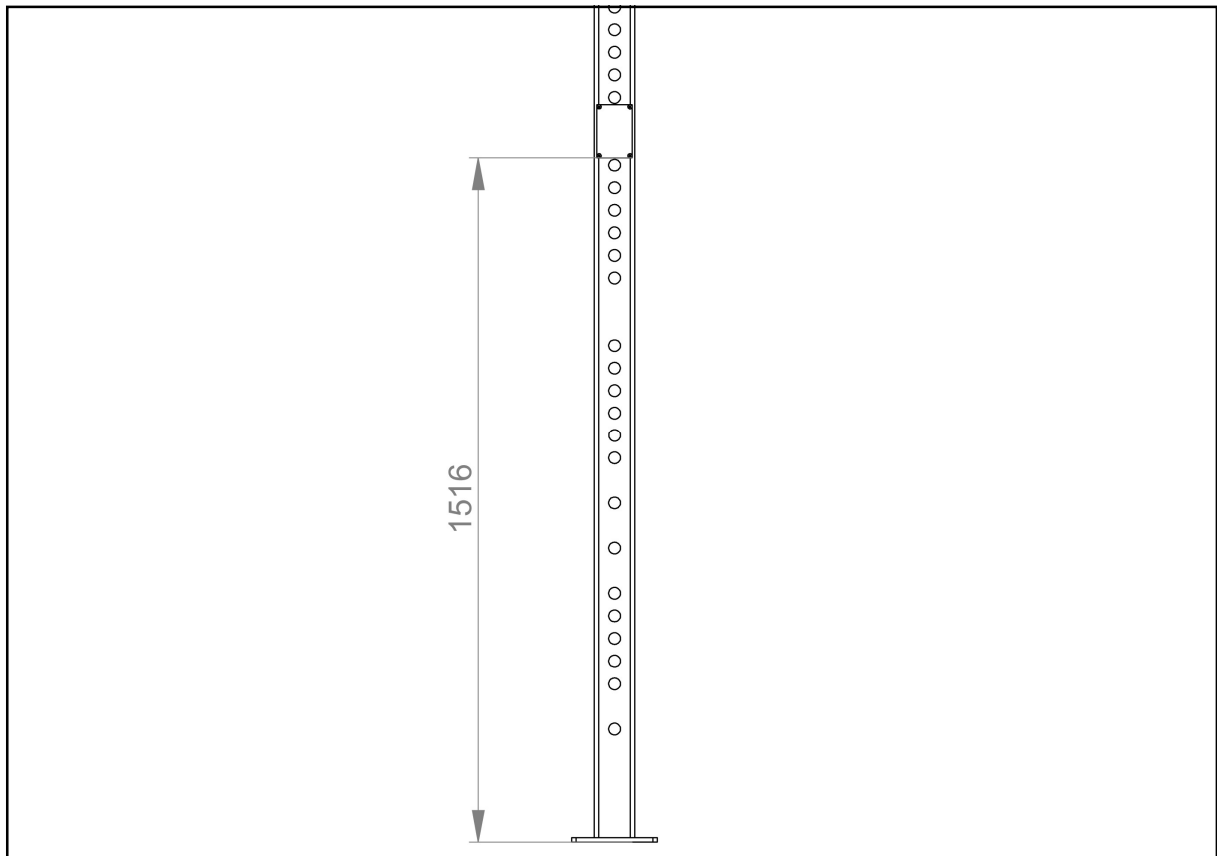
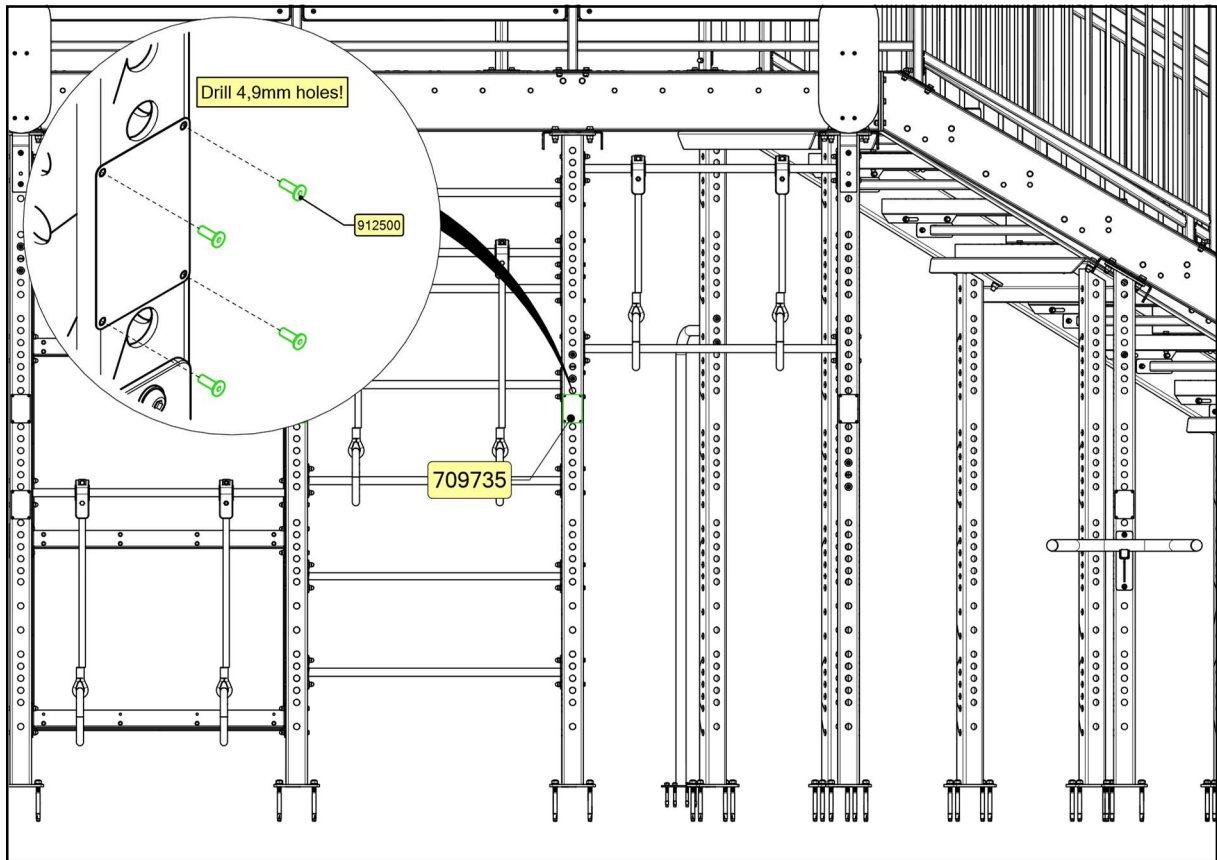

SISU FITNESS STAIRS

SIGN 8

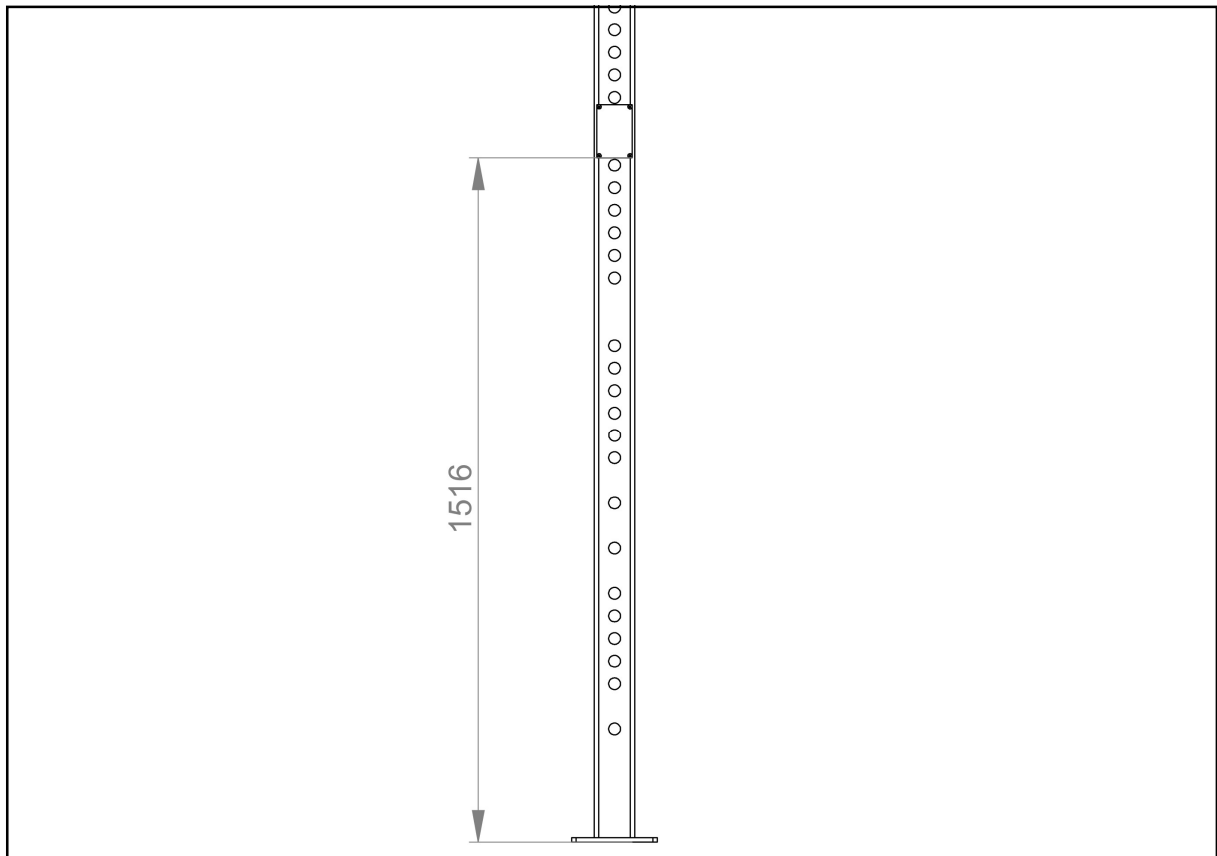
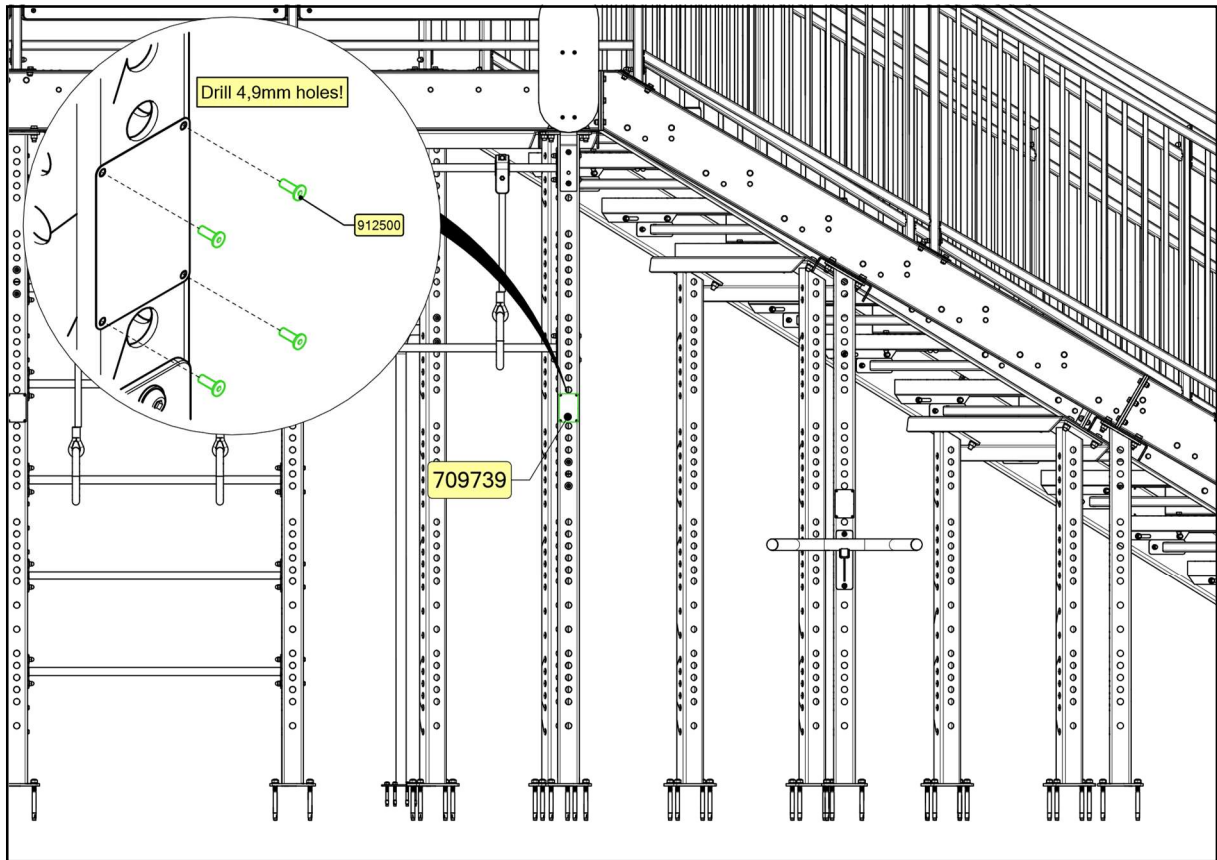

SISU FITNESS STAIRS

SIGN 9

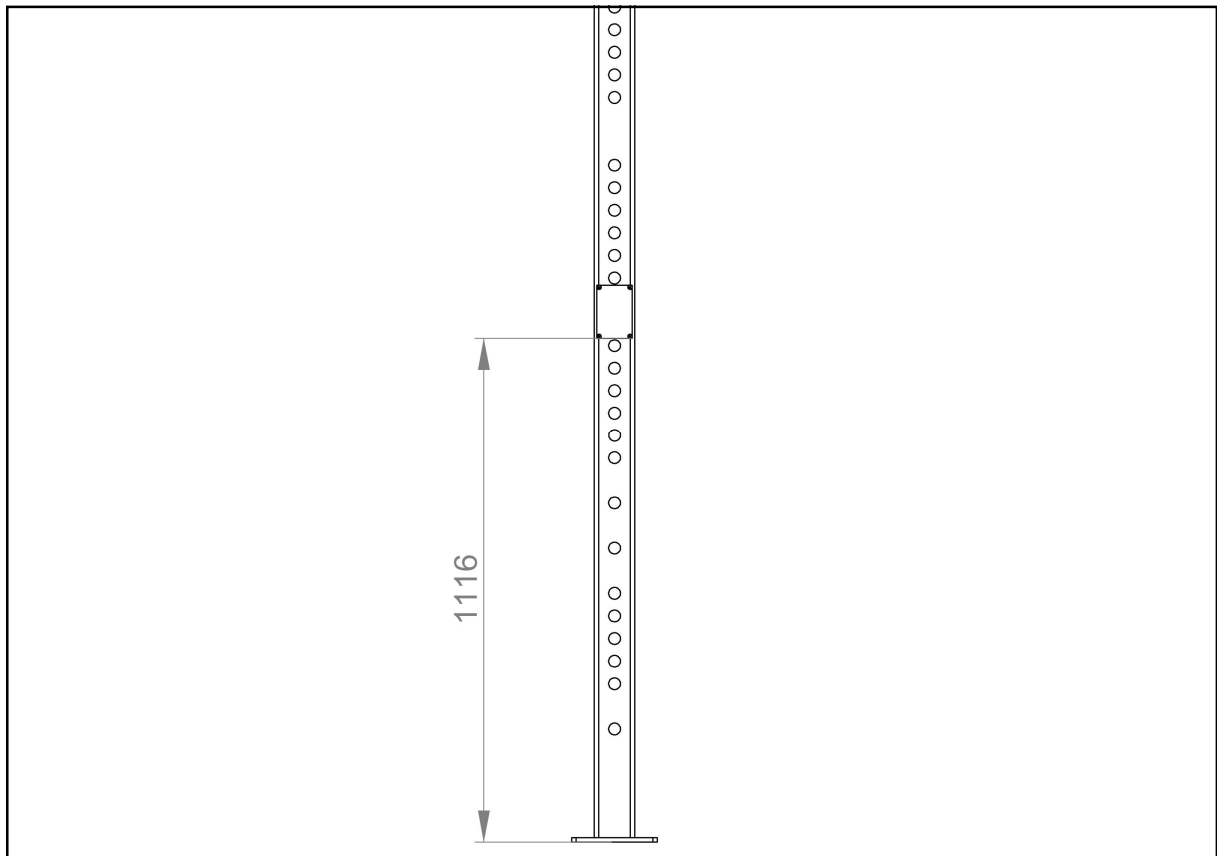
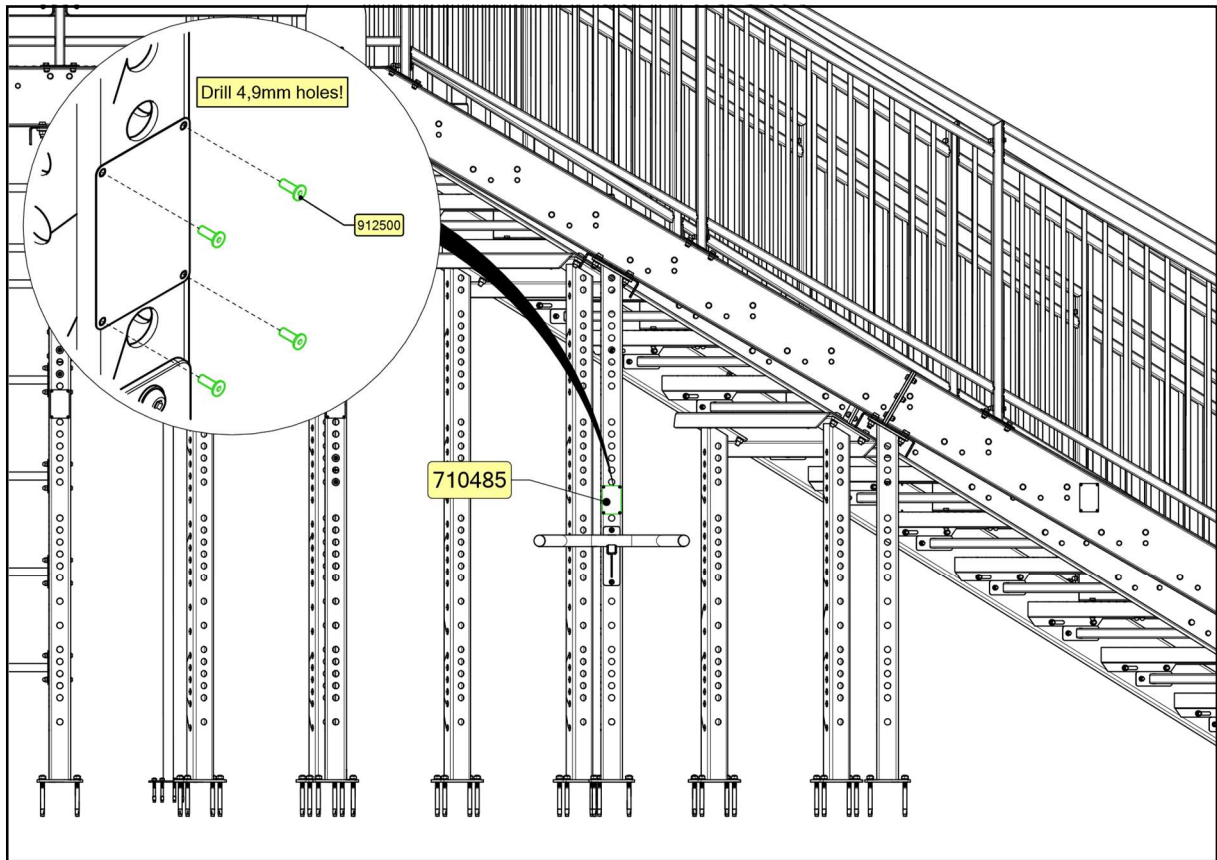

SISU FITNESS STAIRS

SIGN 10

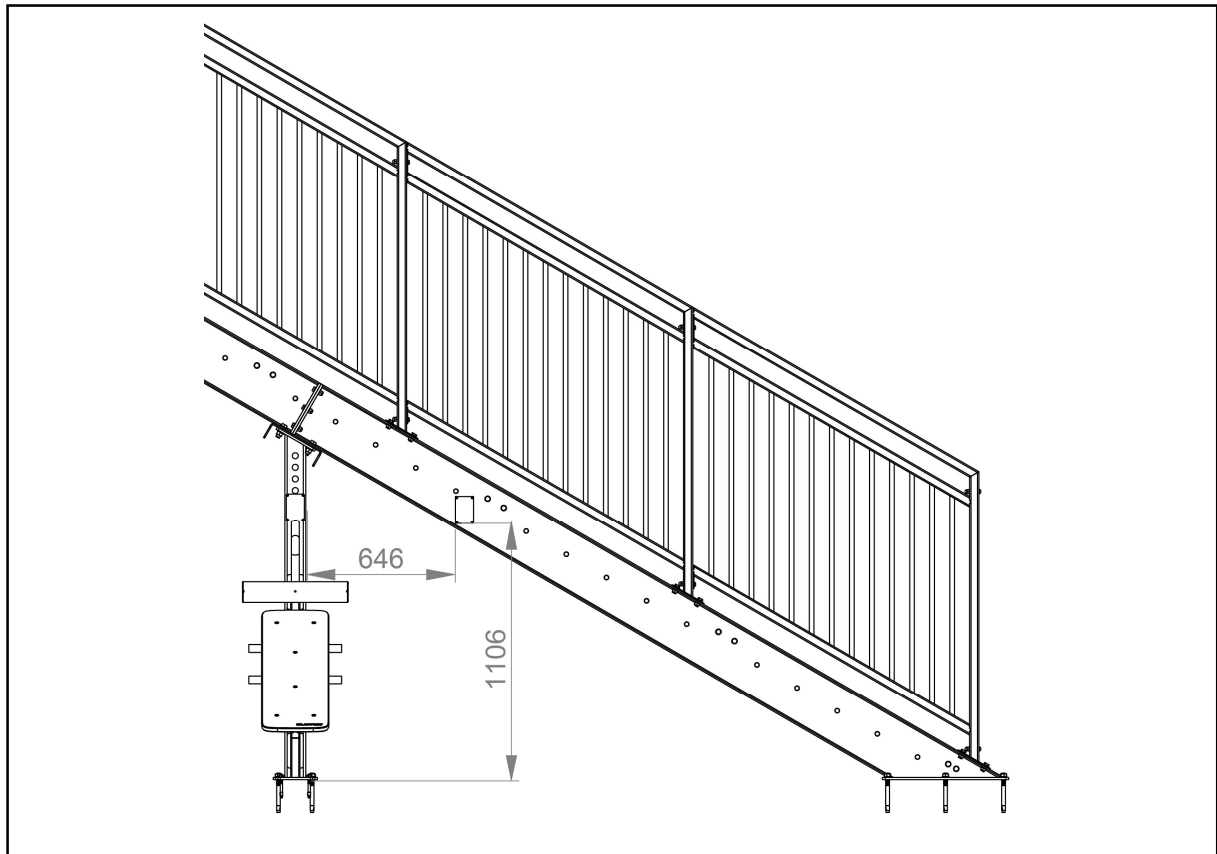
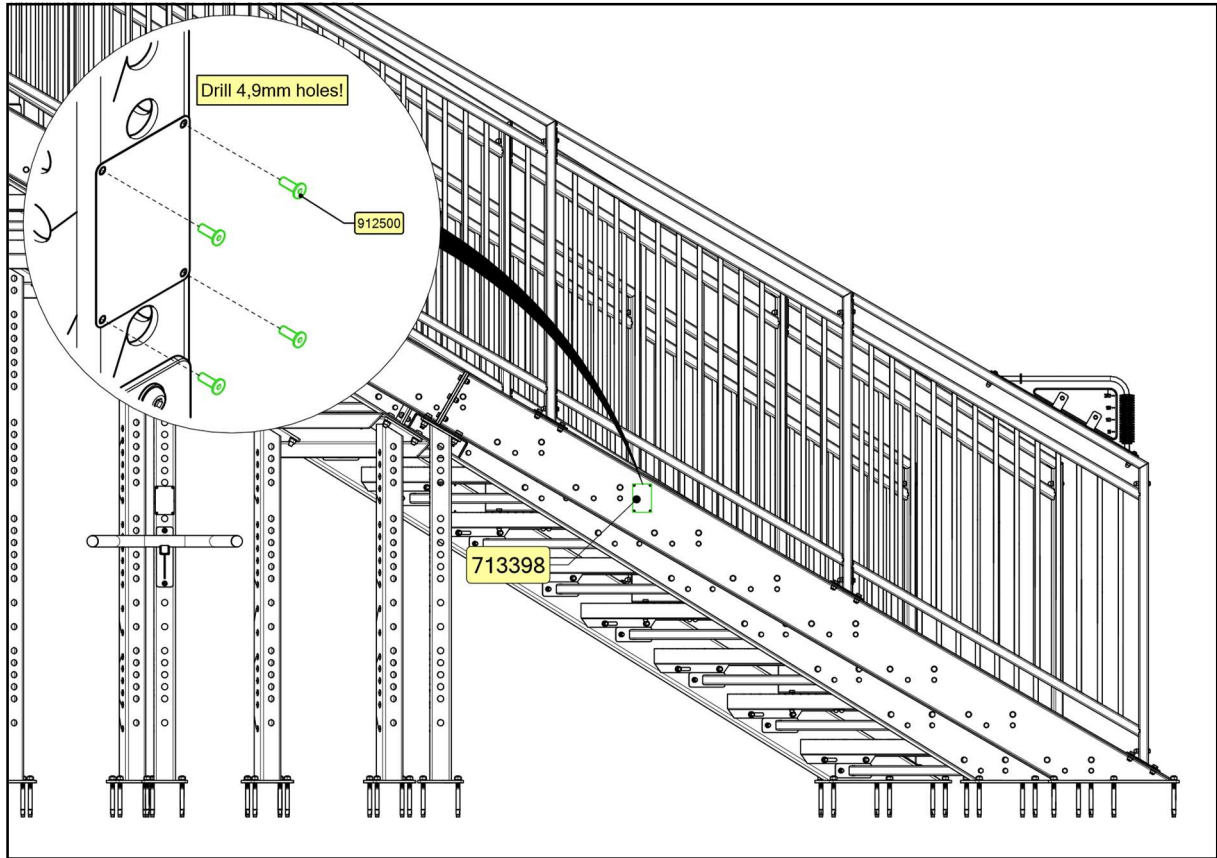

SISU FITNESS STAIRS

SIGN 11

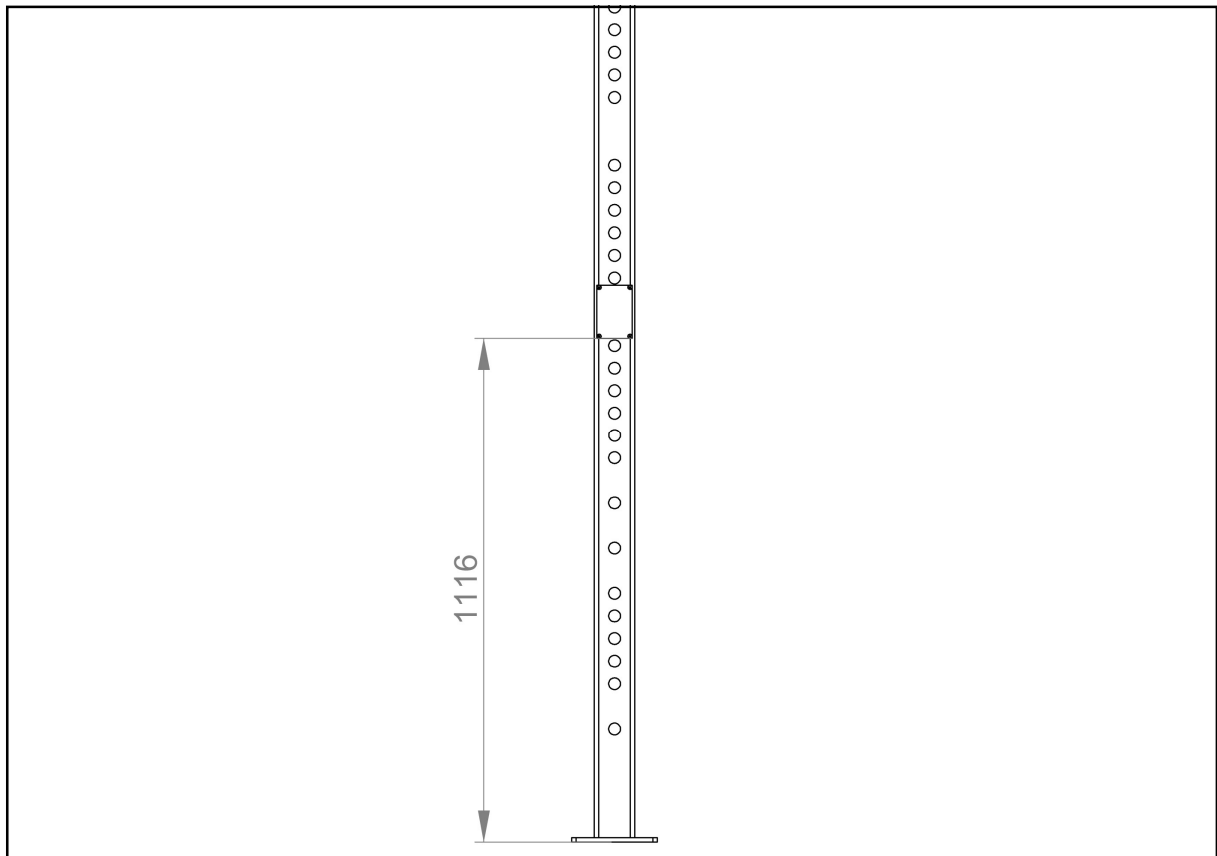
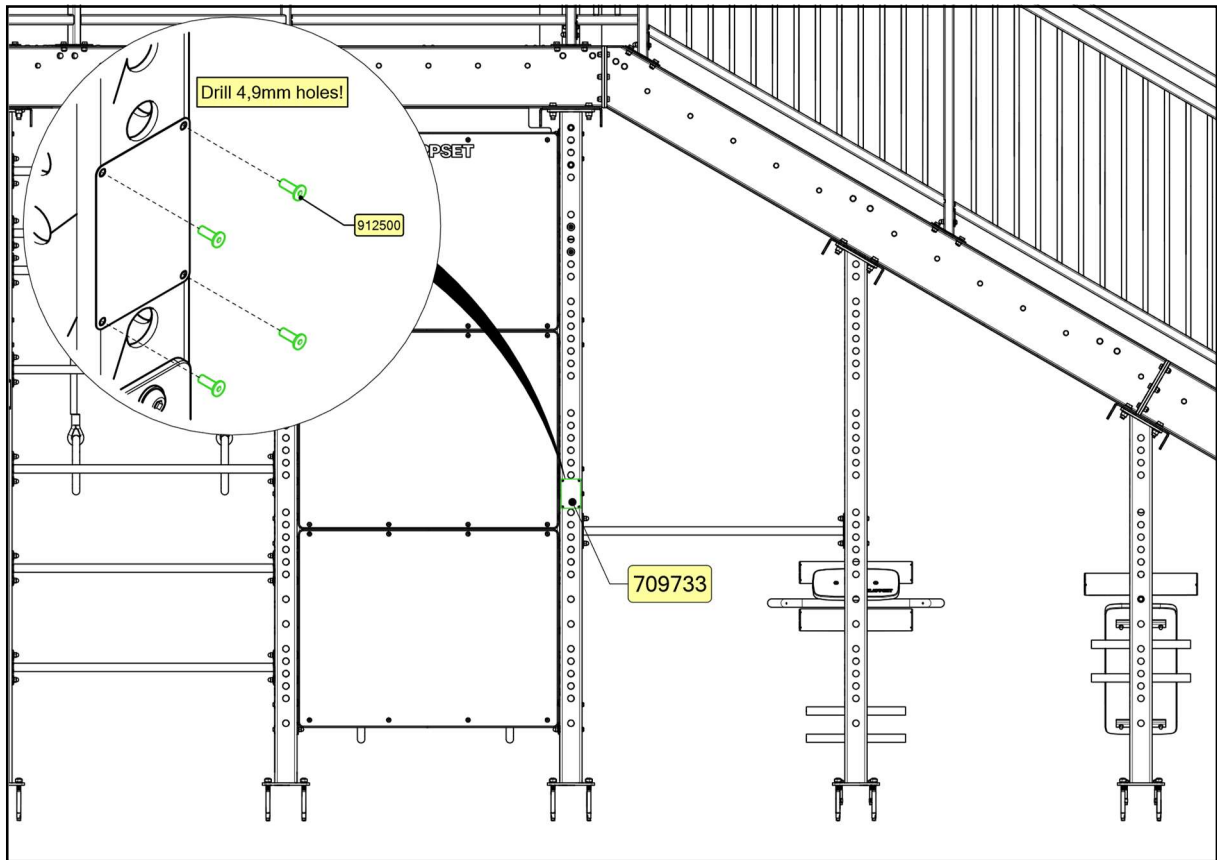

SISU FITNESS STAIRS

SIGN 12

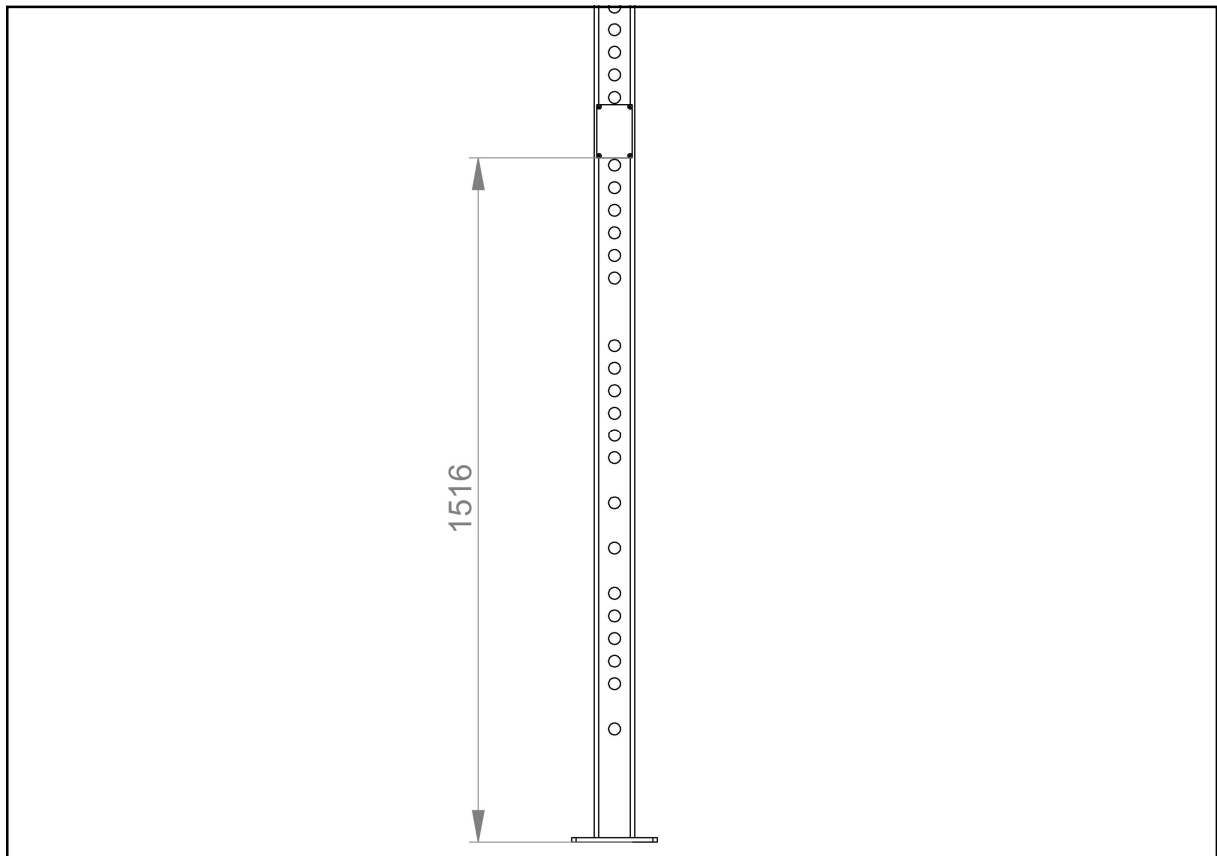
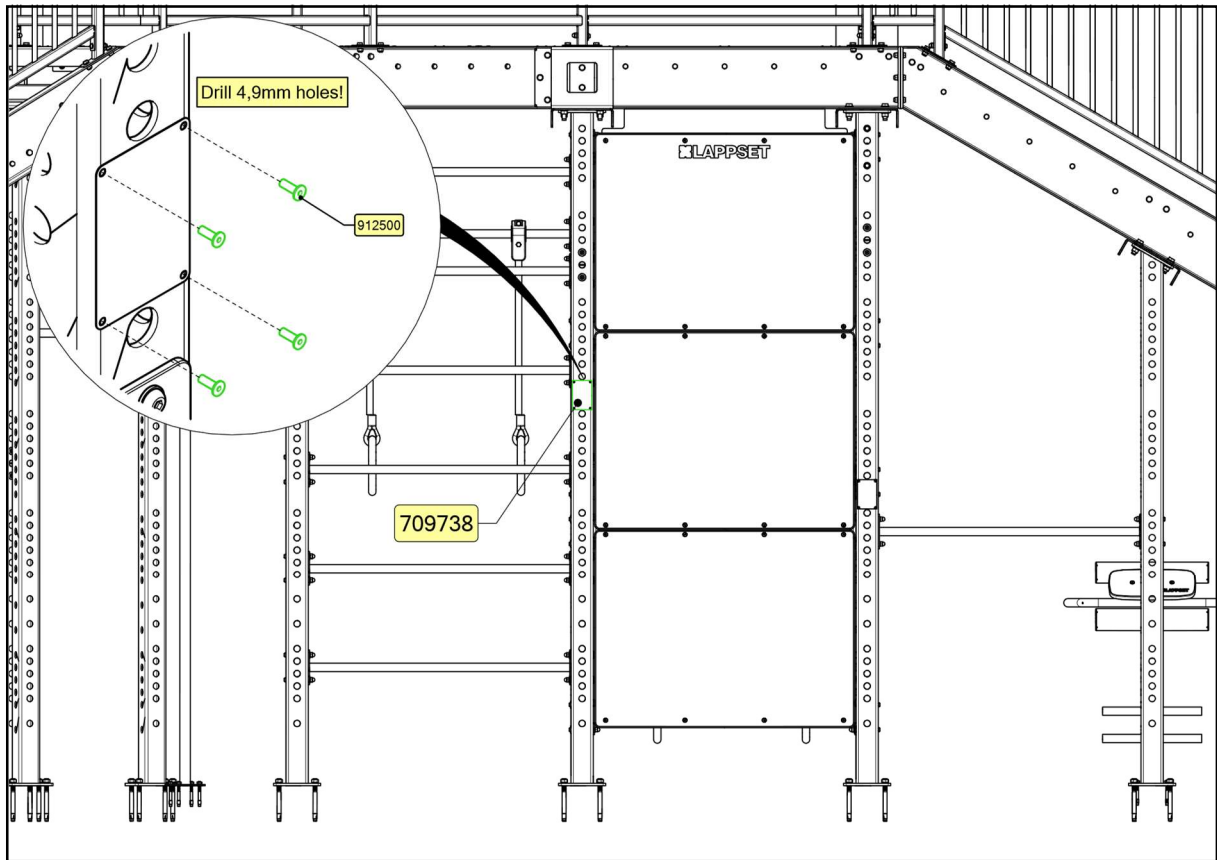

SISU FITNESS STAIRS

SIGN 13

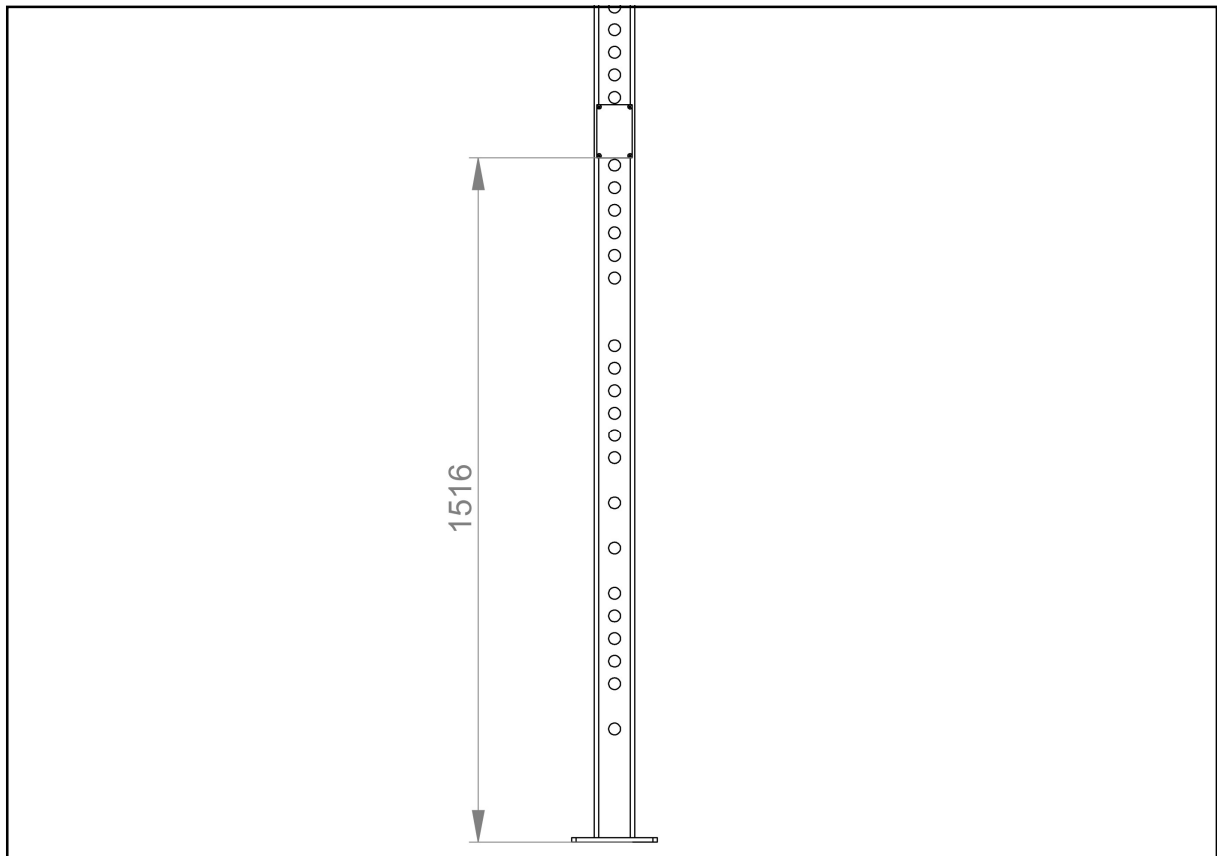
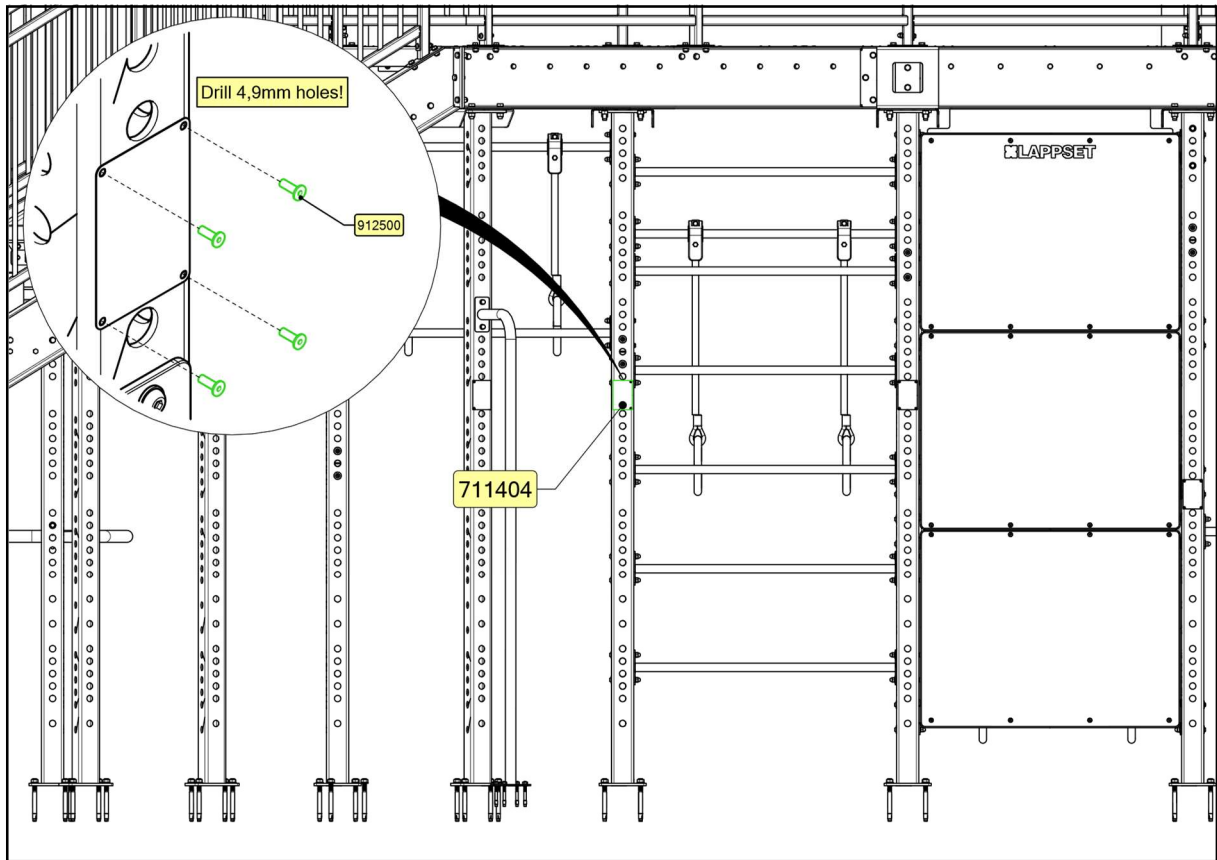

SISU FITNESS STAIRS

SIGN 14

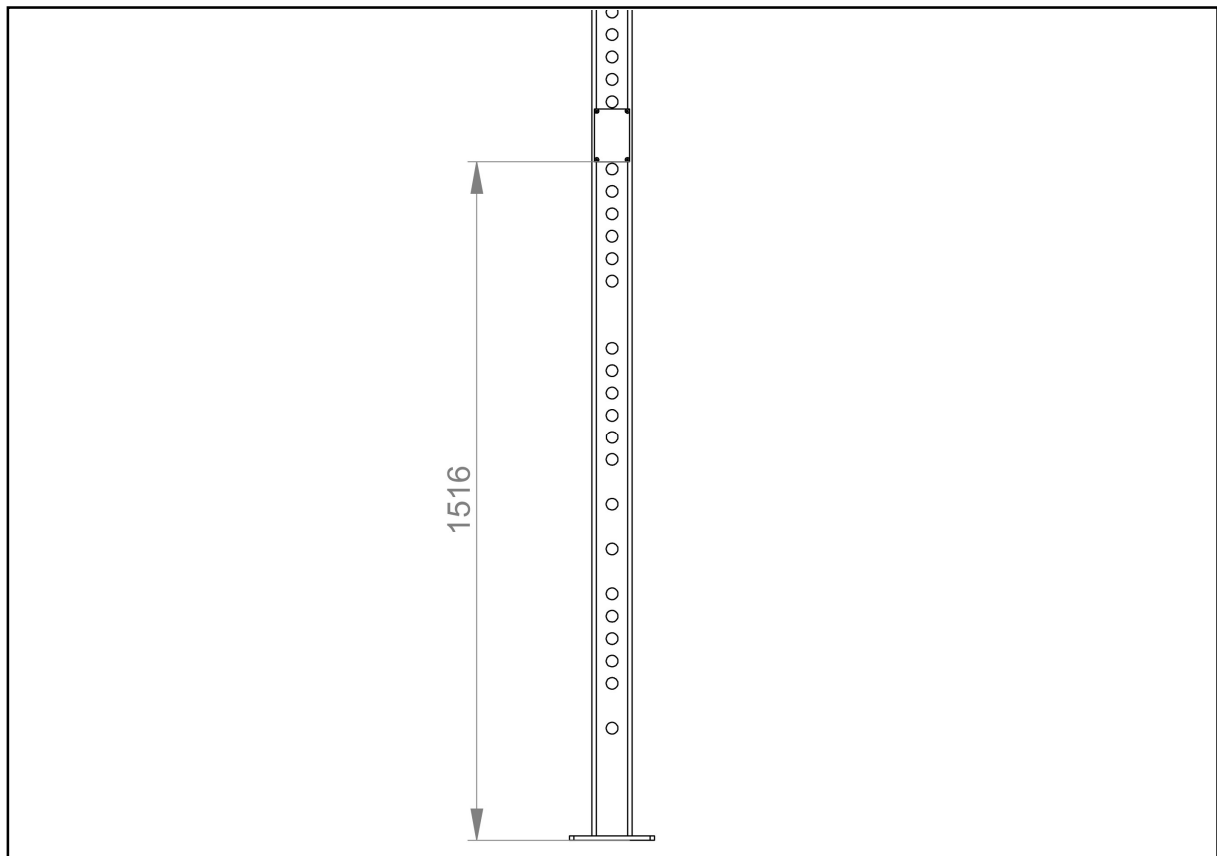
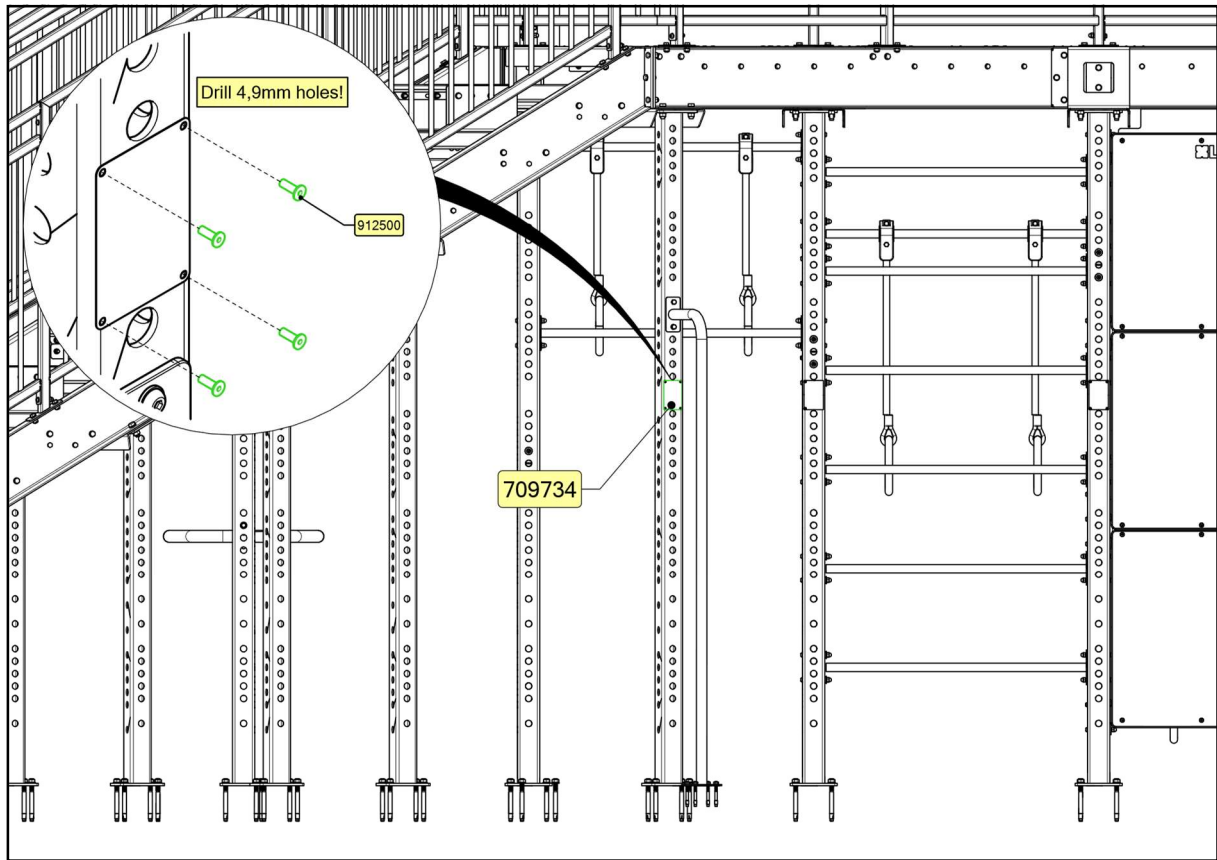

SISU FITNESS STAIRS

SIGN 15

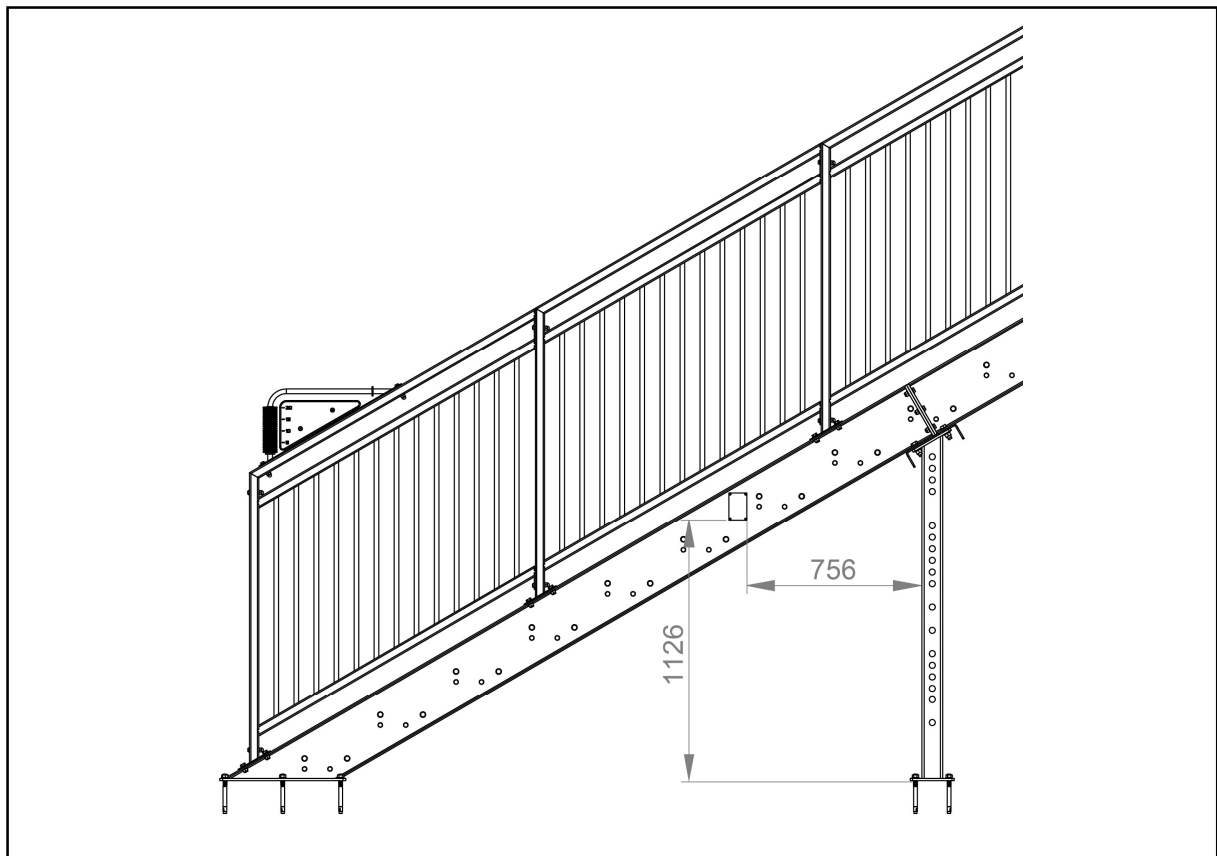
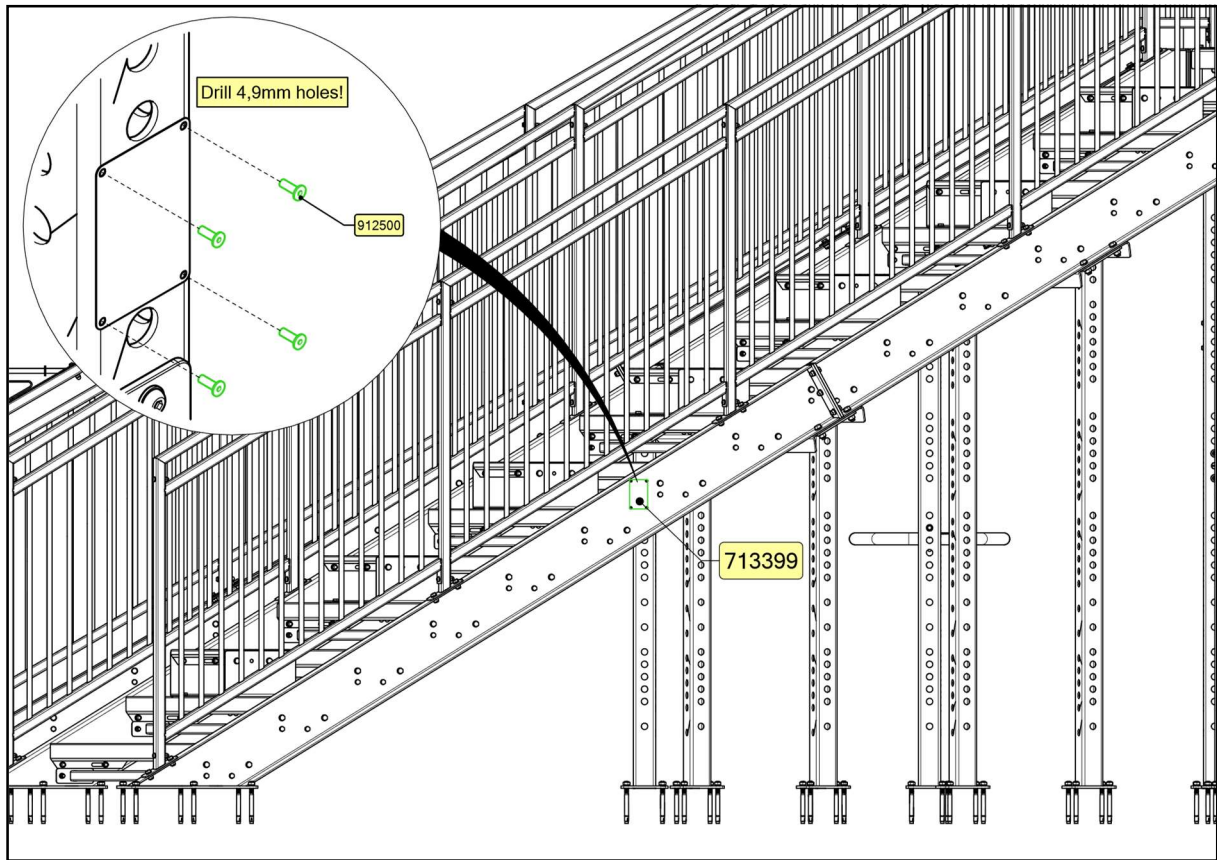

SISU FITNESS STAIRS

PRODUCT SIGN

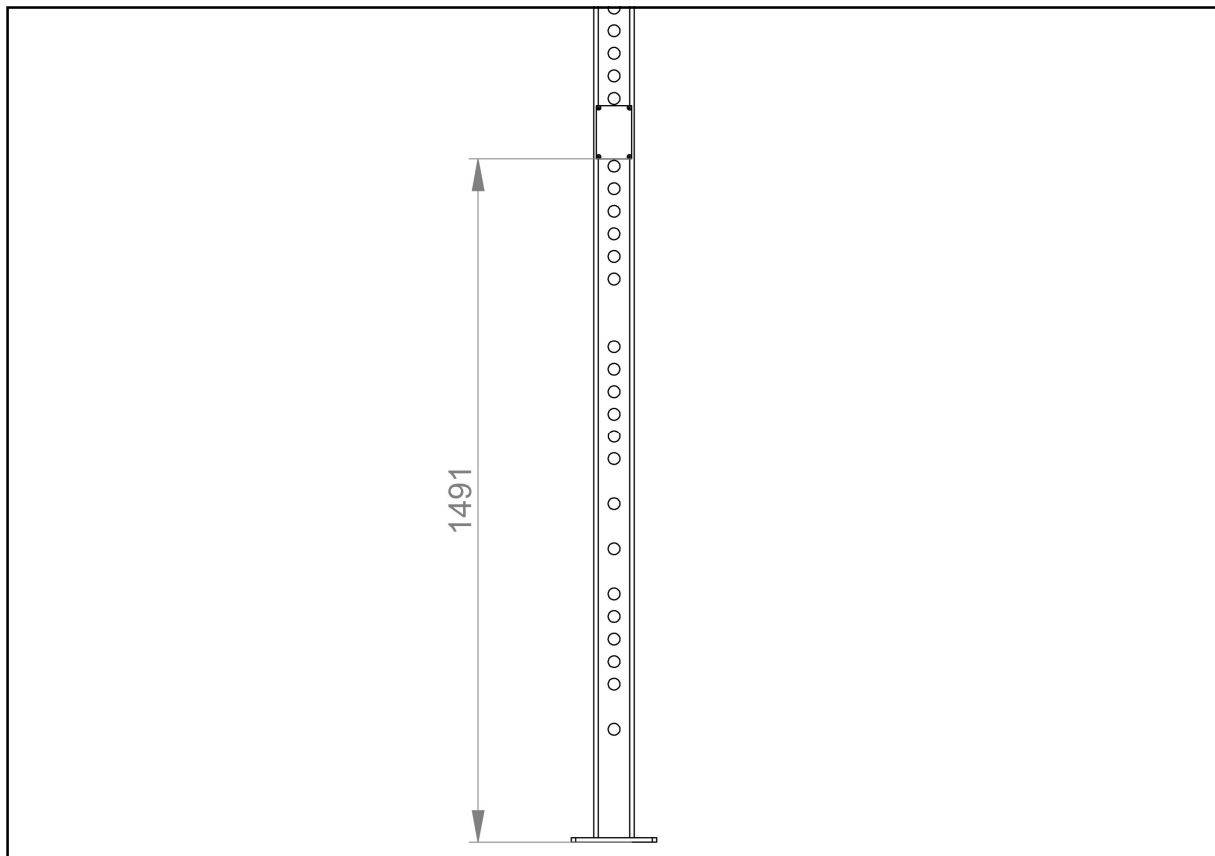
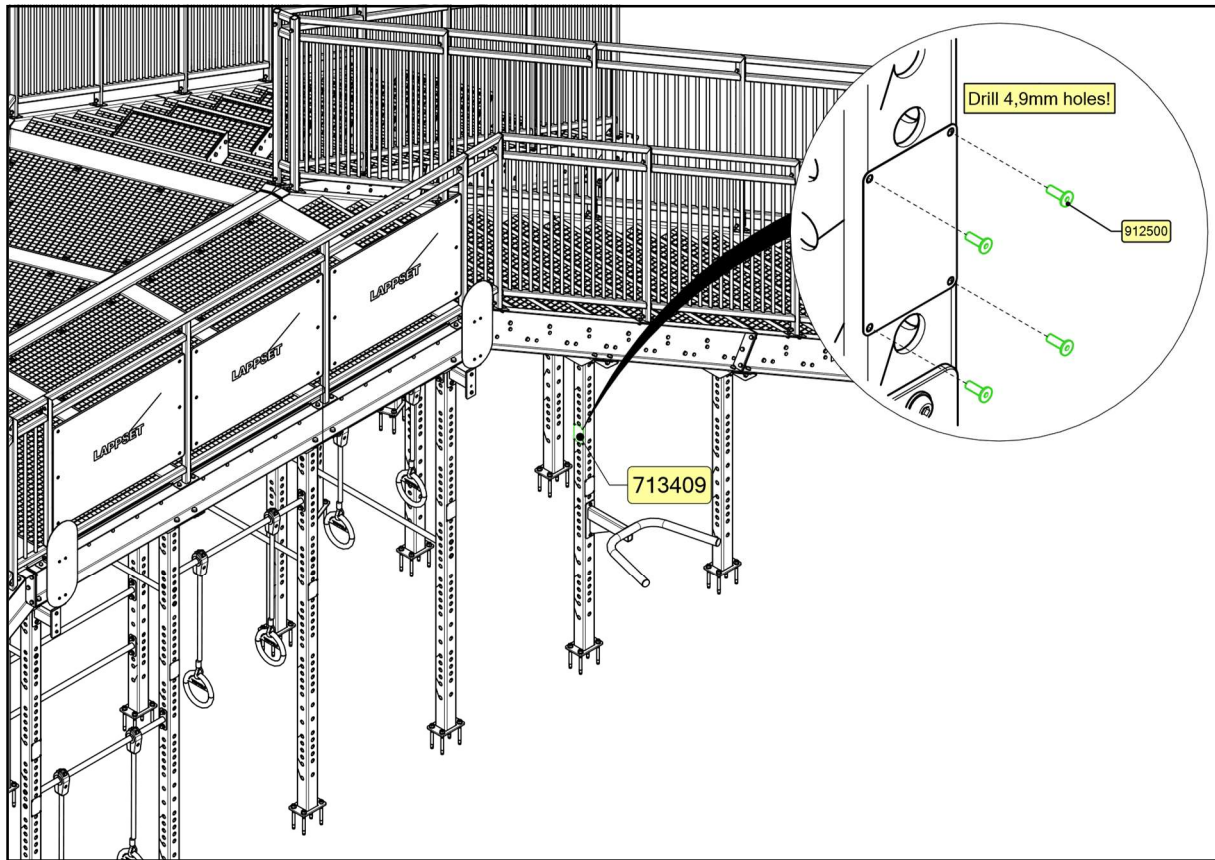

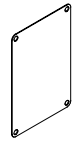
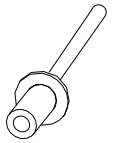
①	SIGN	PCS	②	905390	PCS
		1			4
	118x78		Ø4,8x28		

