

1:135

1:135

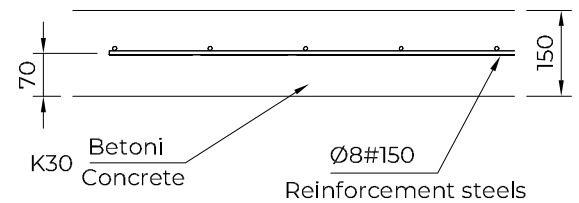
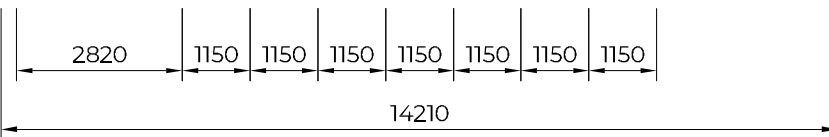
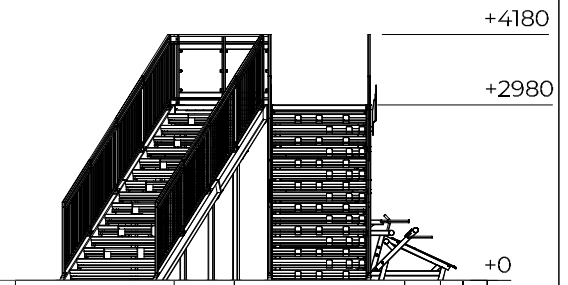
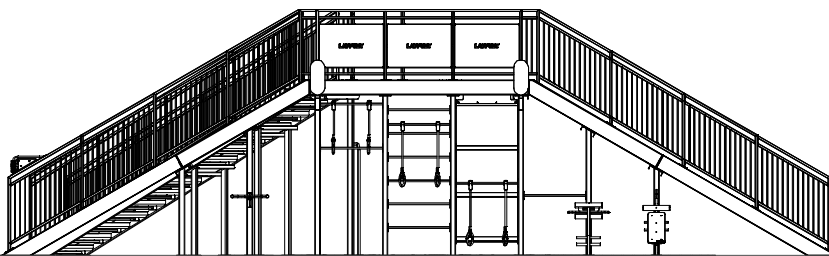

- Area of Movement 106.6 m<sup>2</sup>
- - - Movement Space 121.3 m<sup>2</sup>
- Training Space 29.2 m<sup>2</sup>

Max Falling Height 2980 mm

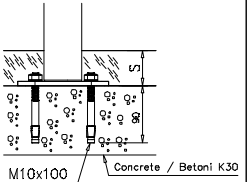
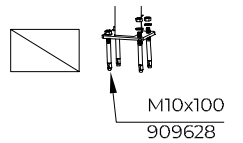
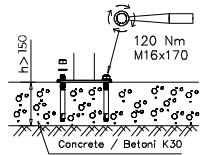
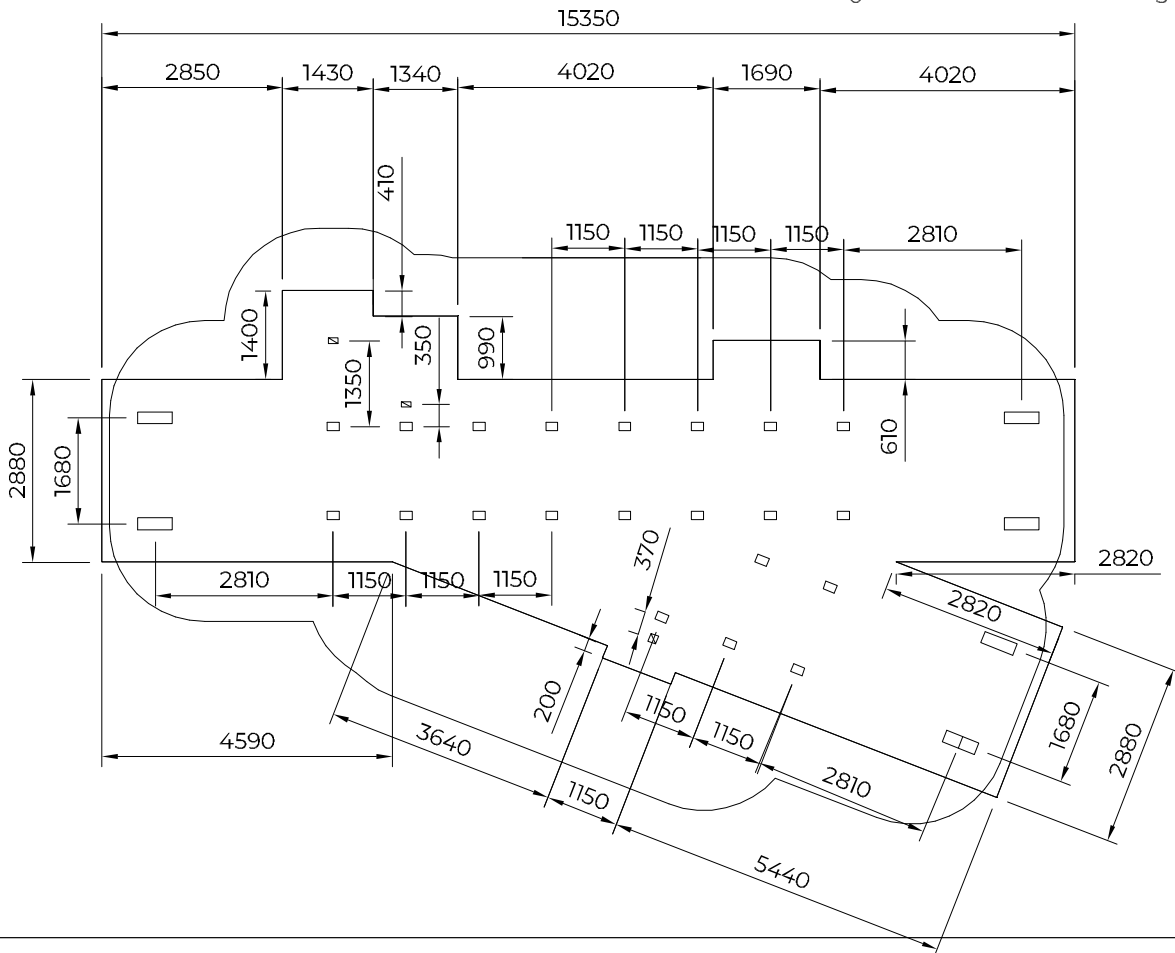
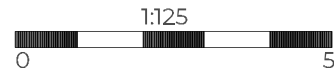
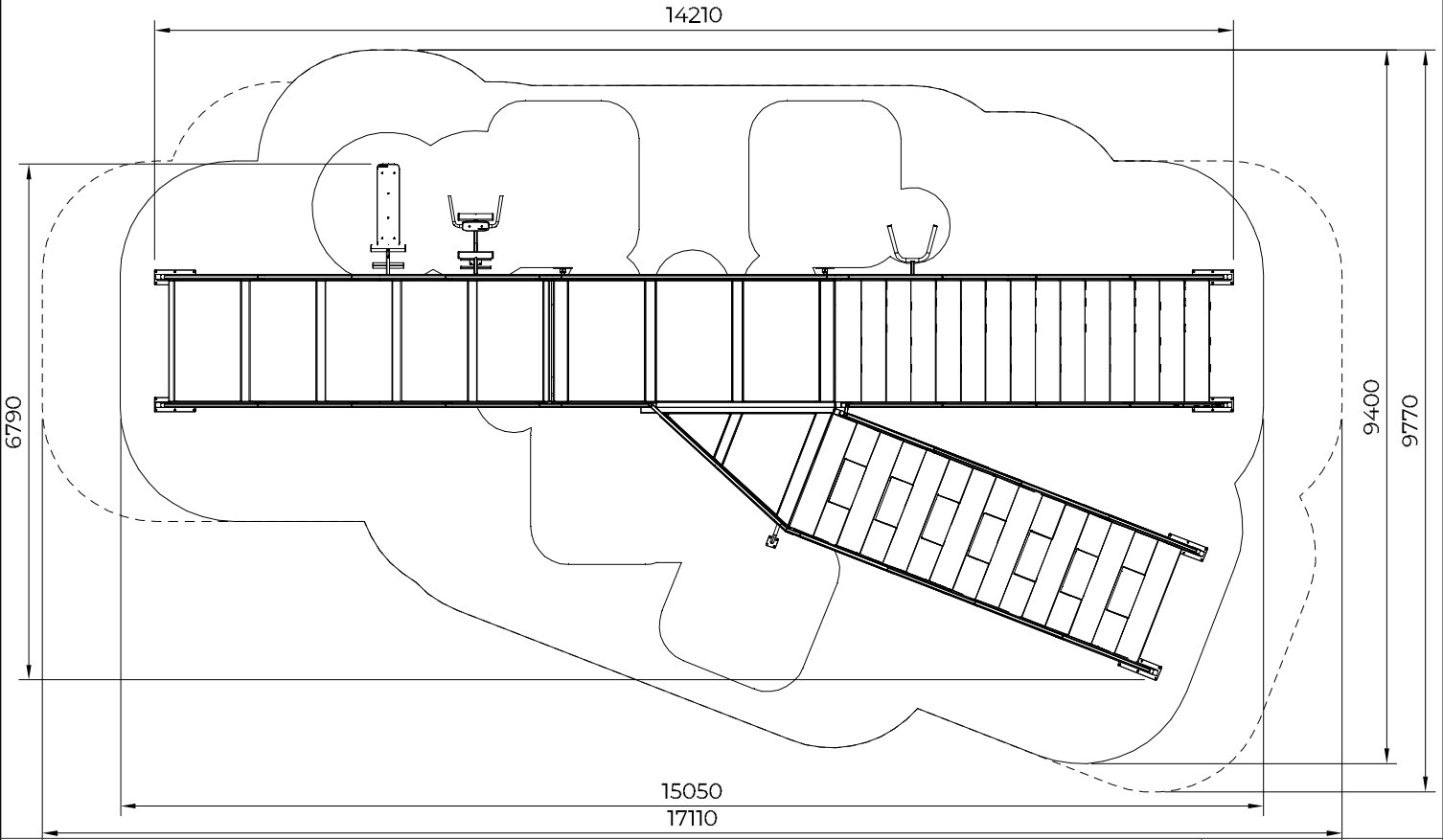

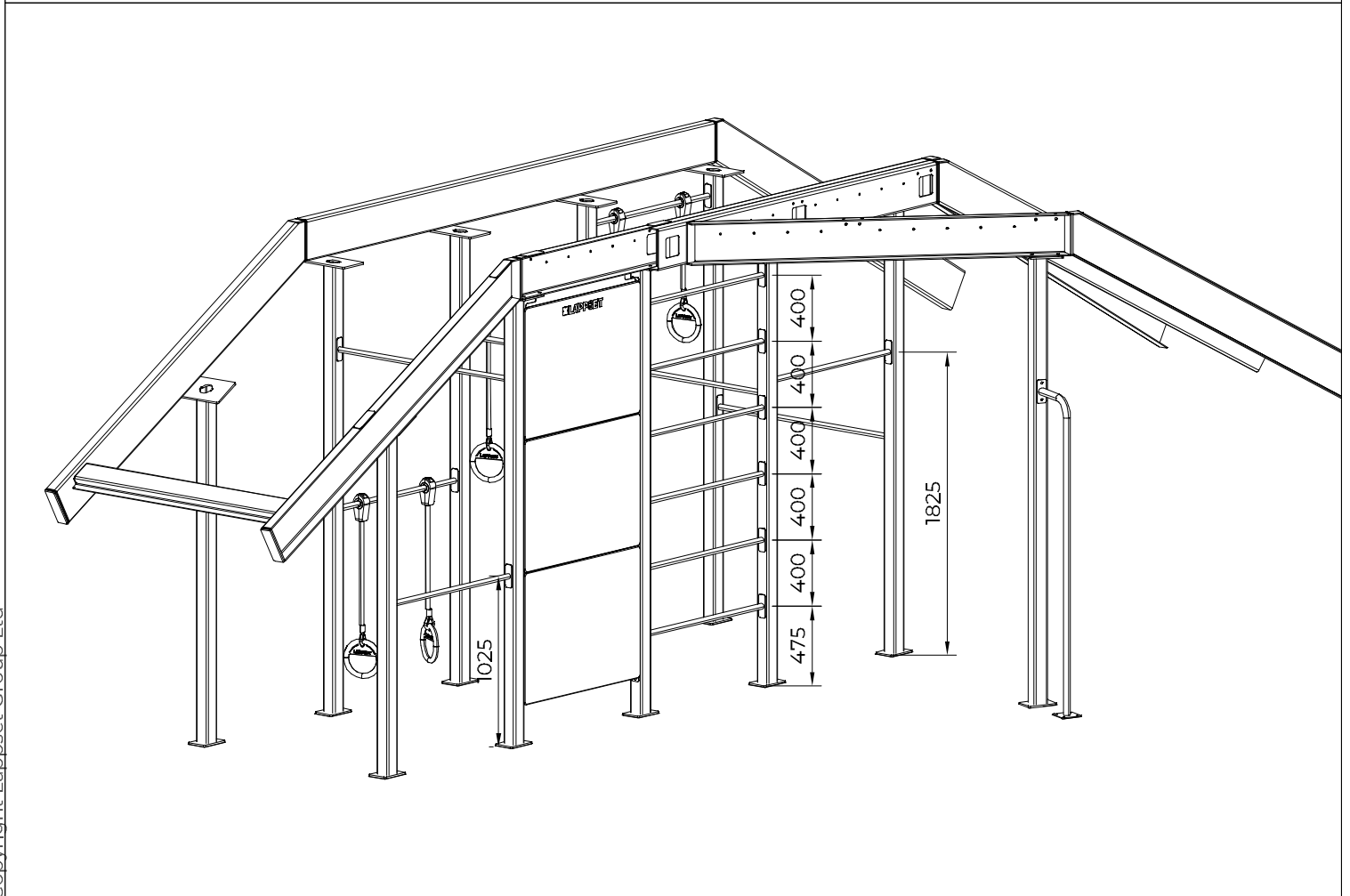
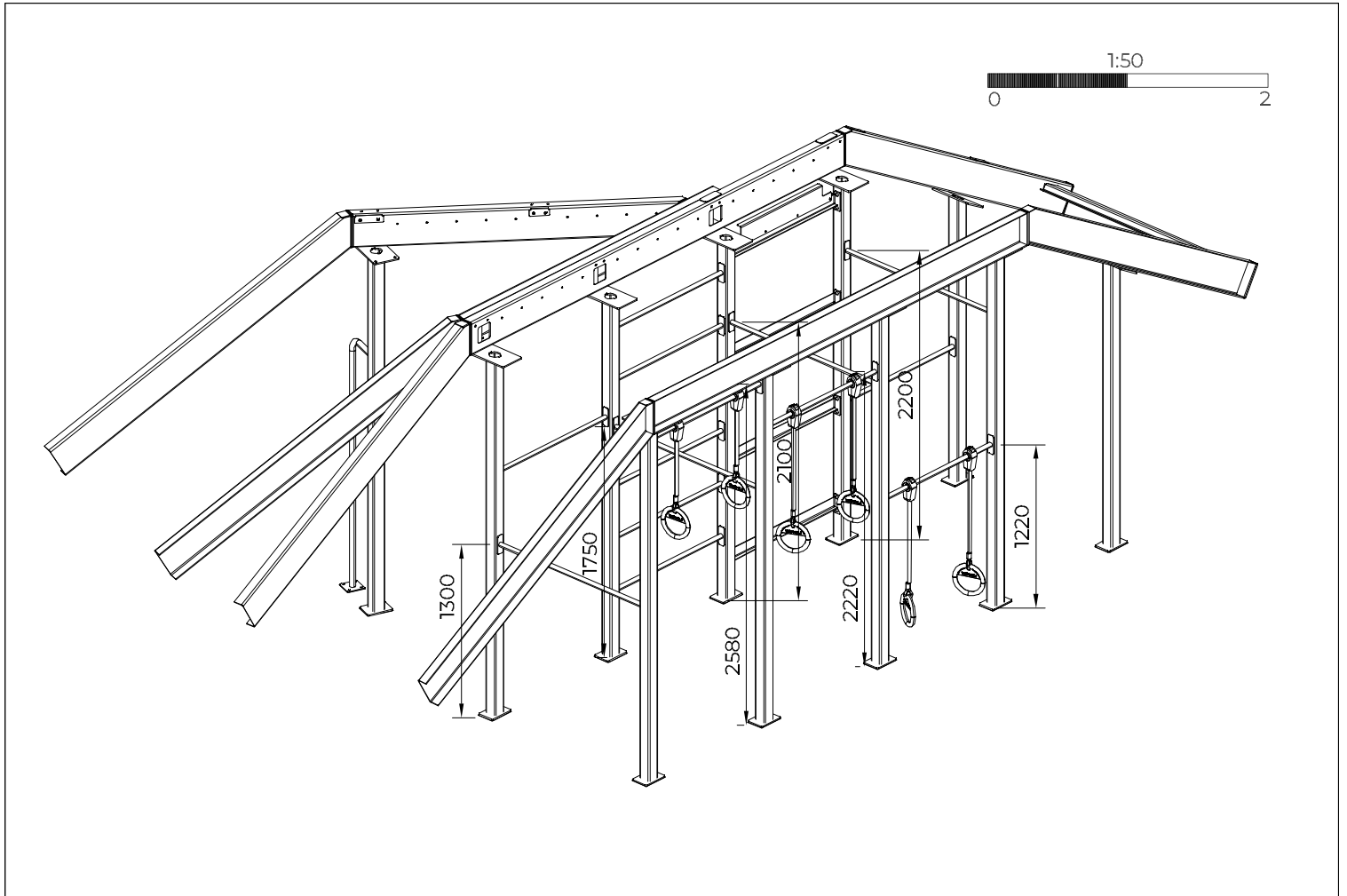

## SISU FITNESS STAIRS

### INSTALLATION MANUAL

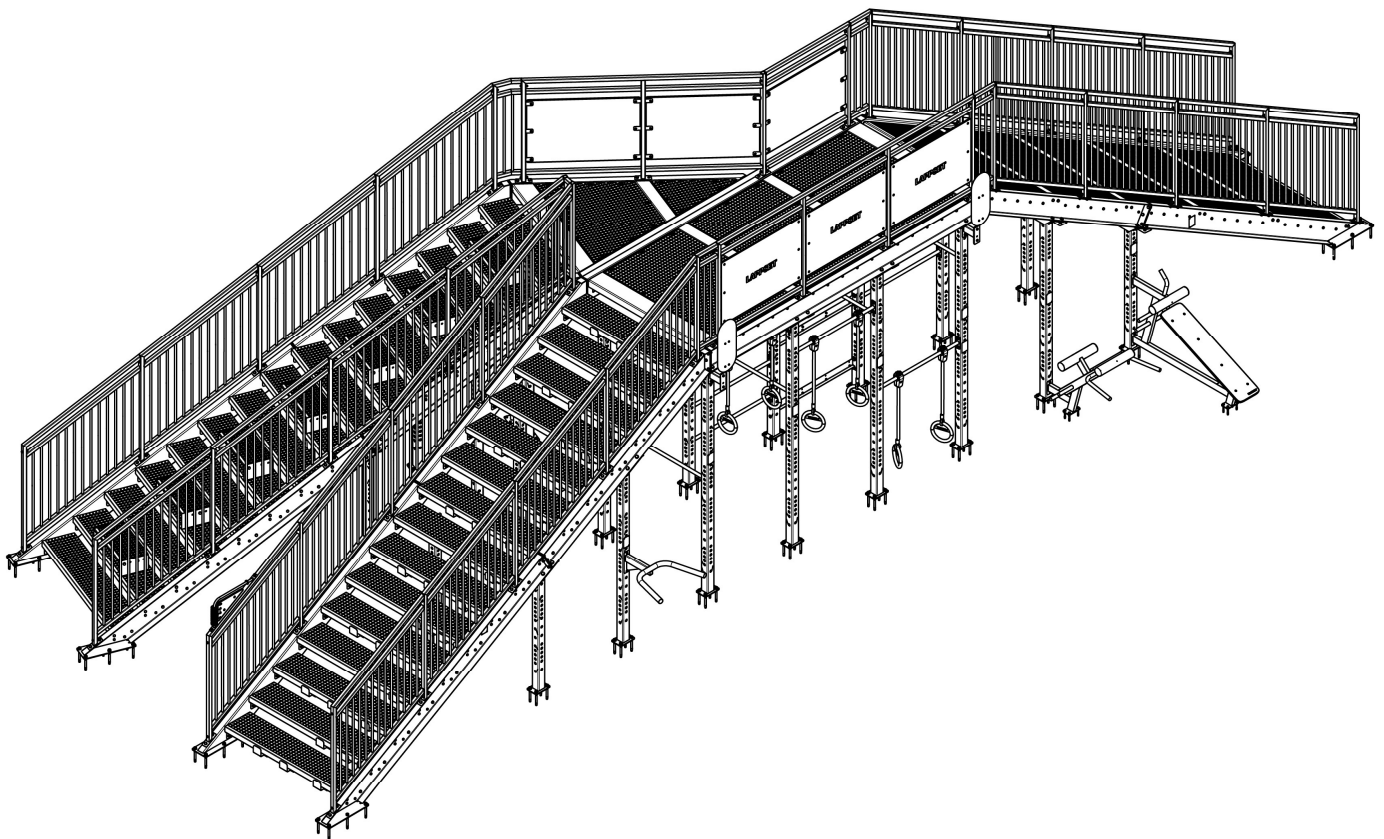

**081876M**

## SISU FITNESS STAIRS

### PART LIST & FASTENING ACCESSORIES

ITEM NO.	PART NUMBER	DESCRIPTION	QTY.
1	709733	SIGN, PULLUP	1
2	709734	SIGN, DRAGON FLAG	1
3	709735	SIGN, GIANT	1
4	709738	SIGN, HANDWALK	1
5	709739	SIGN, BALLWALL	2
6	710040	SIGN, PULLUP	1
7	710483	SIGN, SIT-UP	1
8	710484	SIGN, BACK EXTENSION	1
9	710485	SIGN, DIP	1
10	711404	SIGN, HUMAN FLAG	1
11	712320	LAMINATE	6
12	712464	ROPE ELEMENT	4
13	712467	ROPE ELEMENT	2
14	712495	LAMINATE	2
15	712496	LAMINATE	1
16	713396	SIGN, RING PUSH-UP	1
17	713397	SIGN, RAMP	1
18	713398	SIGN, STAIRS	1
19	713399	SIGN, STAIRS WITH EXTRA STEP	1
20	713410	PRODUCT SIGN	1
21	900965	CAP NUT, M10, DIN 986, nyloc rst	174
22	901302	WASHER, (M10), DIN 125, A2	165
23	902195	CLAMP	12
24	902232	ALLEN SCREW, M10x55, A2 + 2 X DELTA GZ	6
25	902233	ALLEN SCREW, M10x30, A2 + 2 X DELTA GZ	6
26	903148	BOLT, M16 x 50, KS, DIN 931 8,8	90
27	903149	BOLT, M12 x 30, KS, DIN 931 5,8	272
28	903158	LOCK NUT, M16, DIN 985, nyloc zn	90
29	904450	ANCHOR, M16x170	120
30	905086	WASHER, DIN 440, HDG	28
31	905827	ALLEN SCREW, M8 x 20	180
32	906006	SLEEVE	12
33	906598	STICKER	1
34	M99452	ALLEN SCREW, M10x30	4
35	909142	BOLT, M12 x 70, KS, DIN 601 4,6	28
36	909248	LOCK NUT, M12, DIN 985, nyloc zn	321
37	909256	WASHER, (M8), DIN 125, A2	360
38	909349	BOLT, M12 x 40, KS, DIN 601 4,6	45
39	909520	WASHER, (M16), DIN 125, A2	184
40	909628	ANCHOR, M10x100	12
41	909629	BOLT, M10 x 30, KS, DIN 933 8,8	218
40	909633	CAP NUT, M8, DIN 986, A2, nyloc rst	250
41	909637	LOCK NUT, M10, DIN 985, nyloc zn	218
42	909638	WASHER, (M10), DIN 125, HDG	517

## SISU FITNESS STAIRS

43	909644	NUT, M12, DIN 986, nyloc rst	28
44	909854	COUNTERSUNK SCREW, M8x50 A4	6
45	910376	BUSHING, Ø30x17	162
46	910416	INSIDE PLUG Ø48/43-45x23	2
47	910455	SUPPORT	1
48	910604	SUPPORT PIECE	4
49	911149	ALLEN SCREW, M10 x 110	87
50	912180	TAPTITE SCREW, M8 x 60, DIN 7500-C, 2 x DELTA	94
51	912500	RIVET, Ø4,8x14	64
52	912515	DIP BAR	1
53	912575	COUNTERSUNK SCREW, M8x110 A4	2
54	914574	FRAME ASSEMBLY	2
55	914579	SUPPORT	8
56	914583	FRAME ASSEMBLY	2
57	914584	FRAME ASSEMBLY	2
58	914585	FRAME ASSEMBLY	2
59	914588	POST	6
60	914590	POST	6
61	914592	FRAME ASSEMBLY	1
62	914595	POST	8
63	914596	SUPPORT	6
64	914597	SUPPORT	2
65	914598	SUPPORT	16
66	914604	SUPPORT	1
67	914605	SUPPORT	1
68	914606	SUPPORT	1
69	914607	SUPPORT	1
70	914610	SUPPORT	2
71	914611	SUPPORT	1
72	914613	POST	1
73	914635	FRAME ASSEMBLY	1
74	914636	FRAME ASSEMBLY	1
75	914637	FRAME ASSEMBLY	1
76	914638	FRAME ASSEMBLY	1
77	914651	HANDRAIL	1
78	914700	HANDRAIL	3
79	914711	HANDRAIL	1
80	914720	HANDRAIL	24
81	914735	GRID	8
82	914736	GRID	1
83	914737	GRID	1
84	914743	TUBE ASSEMBLY	2
85	914746	BAR ELEMENT	4
86	914747	BAR ELEMENT	11
87	914751	TUBE ASSEMBLY	30
88	914753	BRACKET	45
89	914777	STEP	30

**SISU FITNESS STAIRS**

90	914797	STEP	7
91	914819	T-33 NORMAL FASTENER	94
92	914835	SUPPORT	14
93	914885	ALLEN SCREW, M10 x 60	72
94	914904	COUNTERSUNK SCREW, M8x25 A2	62
95	915360	COVER	5
96	915361	COVER	1
97	915384	FRAME ASSEMBLY	1
98	915387	FRAME ASSEMBLY	1
99	915389	FRAME ASSEMBLY	1
100	915391	SUPPORT	1
101	915392	SUPPORT	1
102	915393	HANDRAIL	1
103	915397	HANDRAIL	1
104	915409	SUPPORT	2
105	915416	COUNTER	1
106	915450	HANDRAIL	1
107	980151	WASHER, (M8), DIN 125, HDG	70
108	980154	WASHER, (M12), DIN 125, HDG	666
109	914838-213	SIGN, YELLOW	15
110	914838-241	SIGN, BLUE	15
111	914838-260	SIGN, RED	15

## SISU FITNESS STAIRS

### STAIRS (2 PCS)

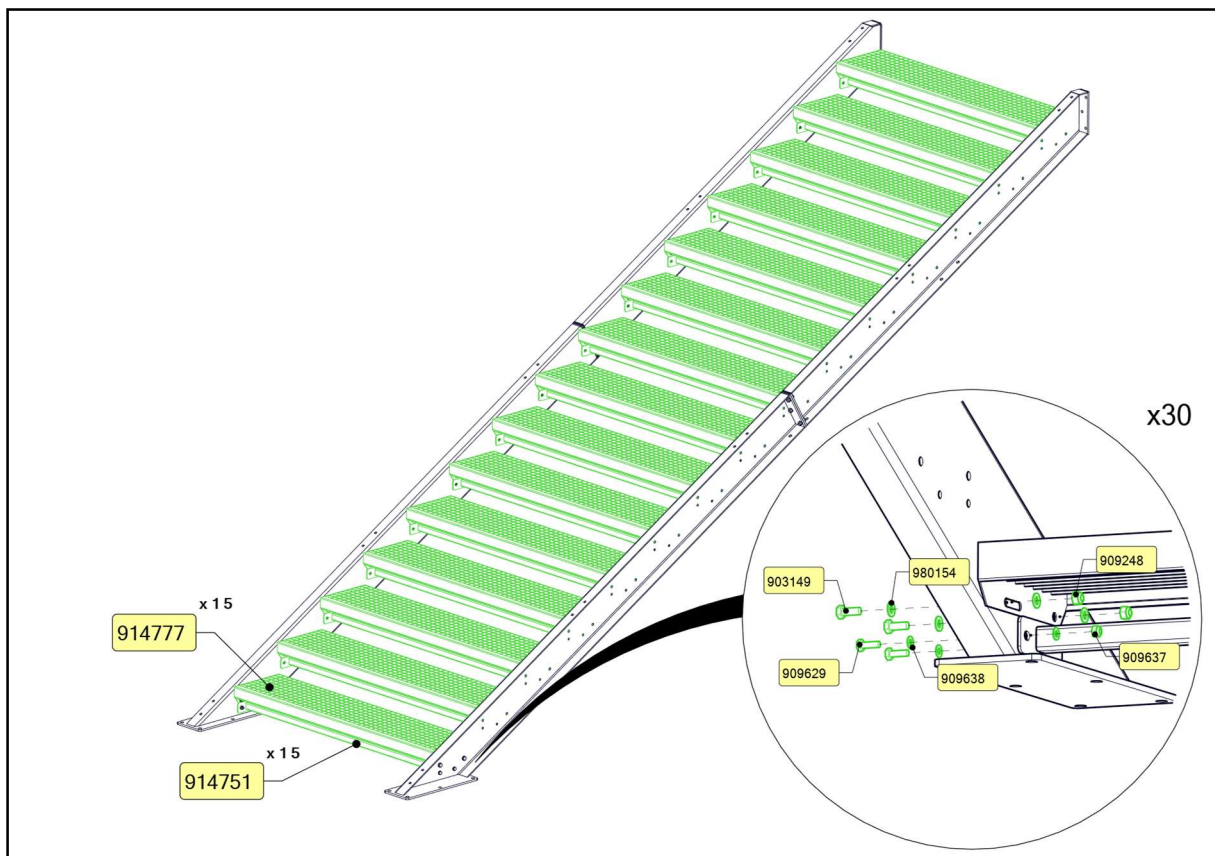
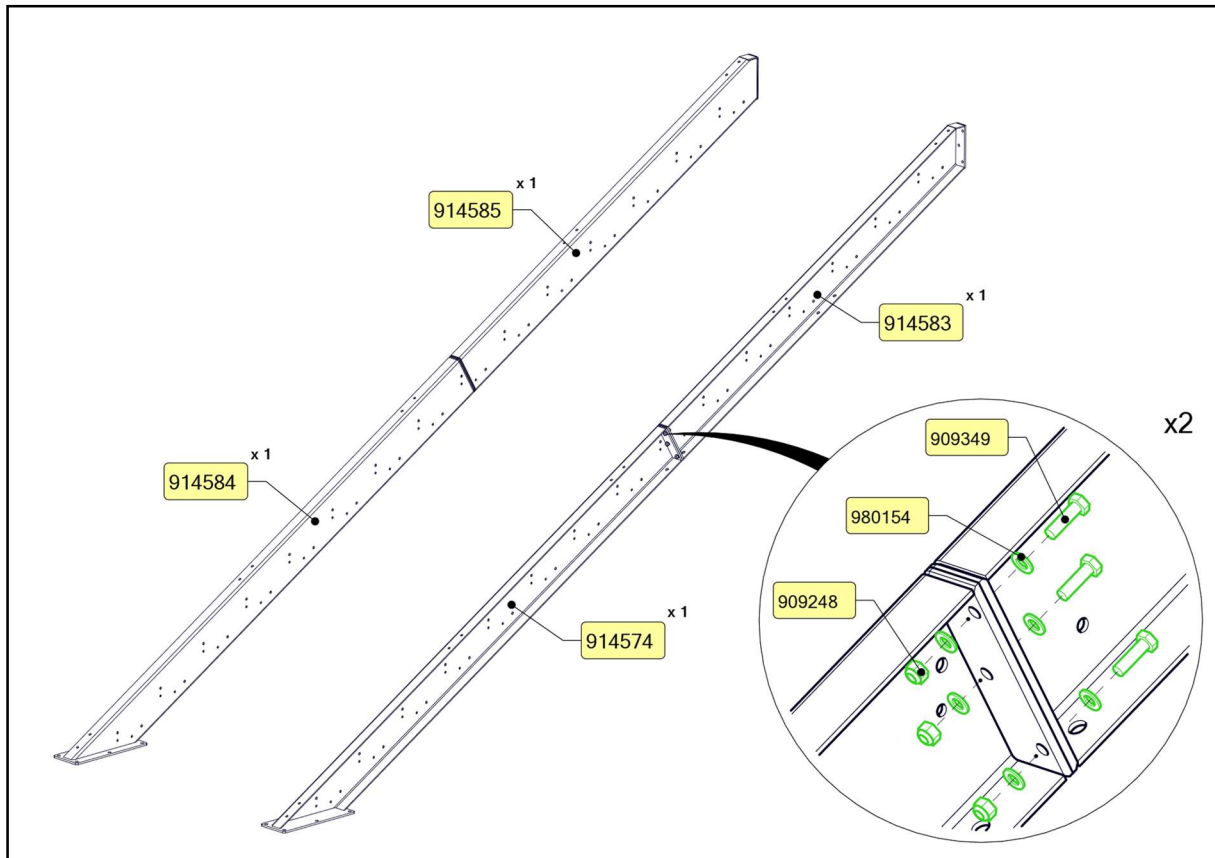

## SISU FITNESS STAIRS

### STAIRS (2 PCS)

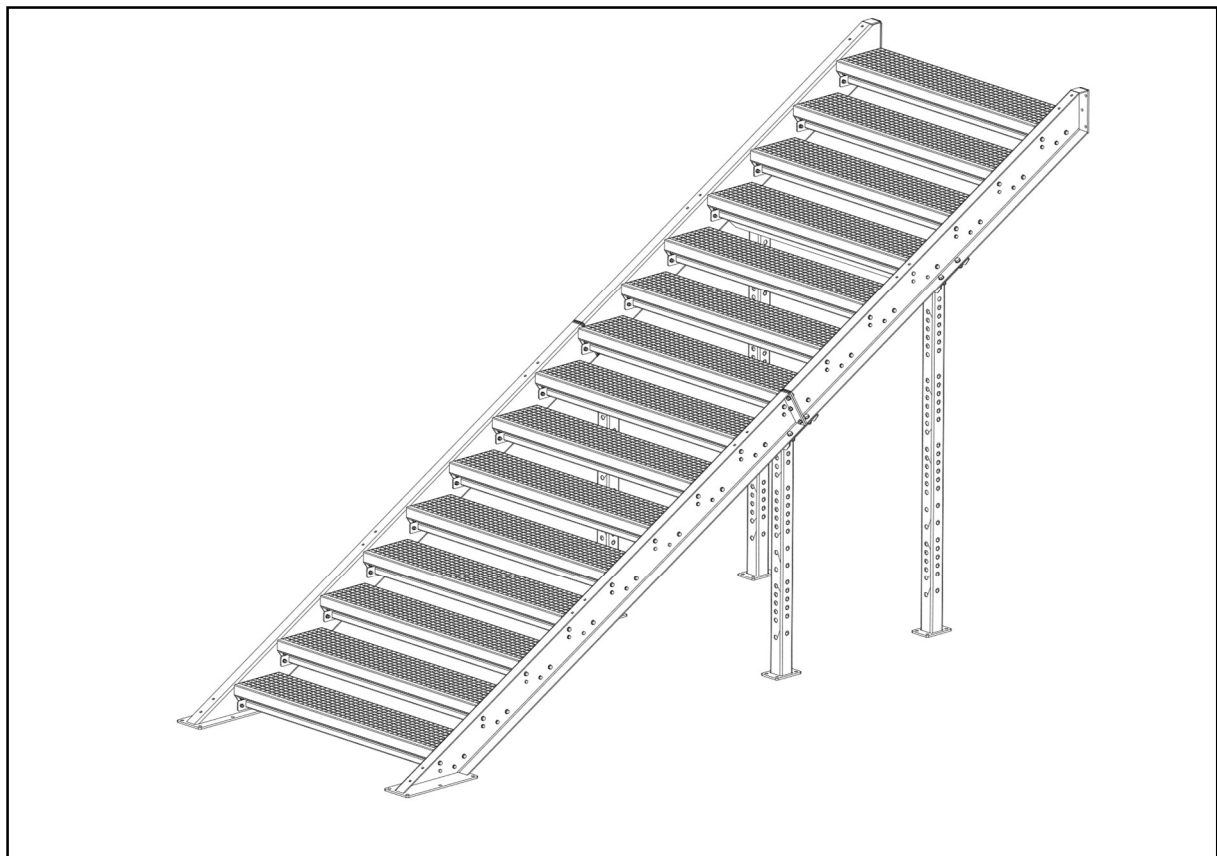
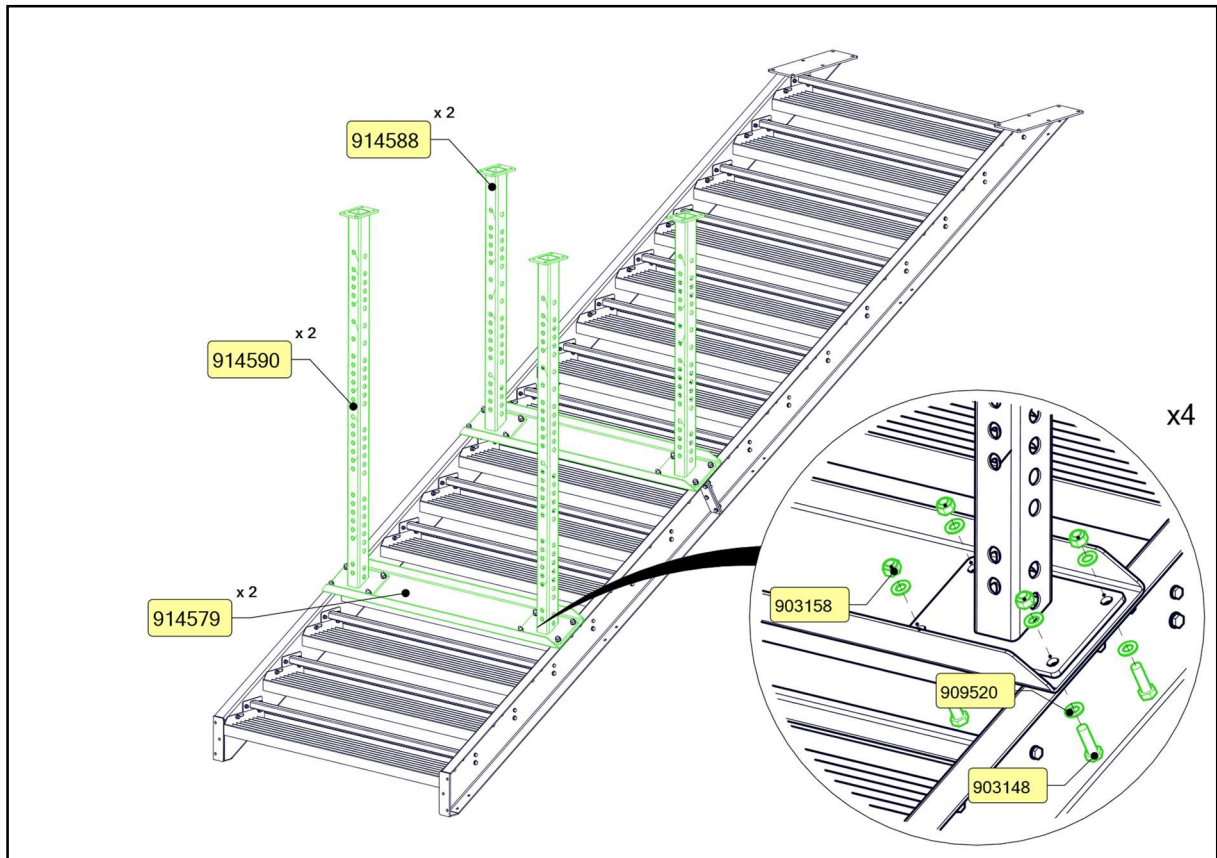

## SISU FITNESS STAIRS

### RAMP (1 PC)

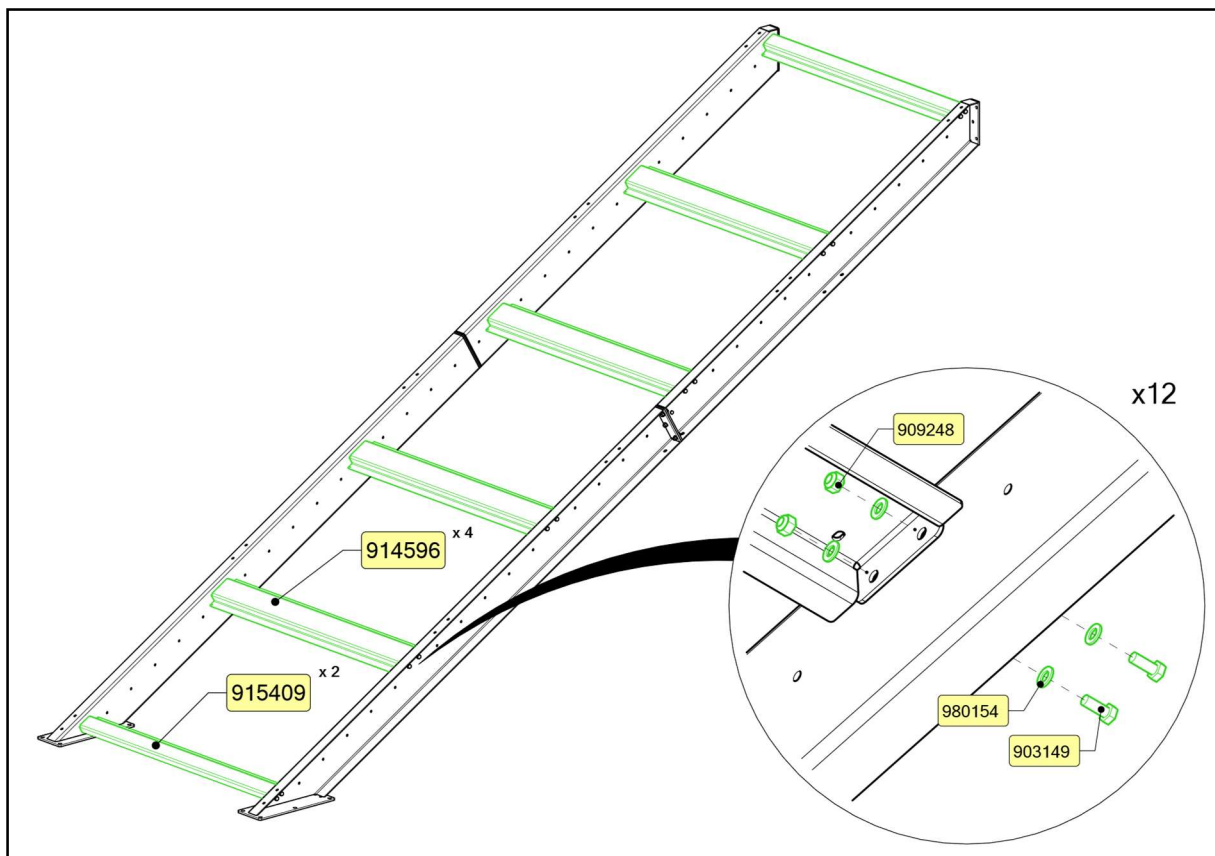
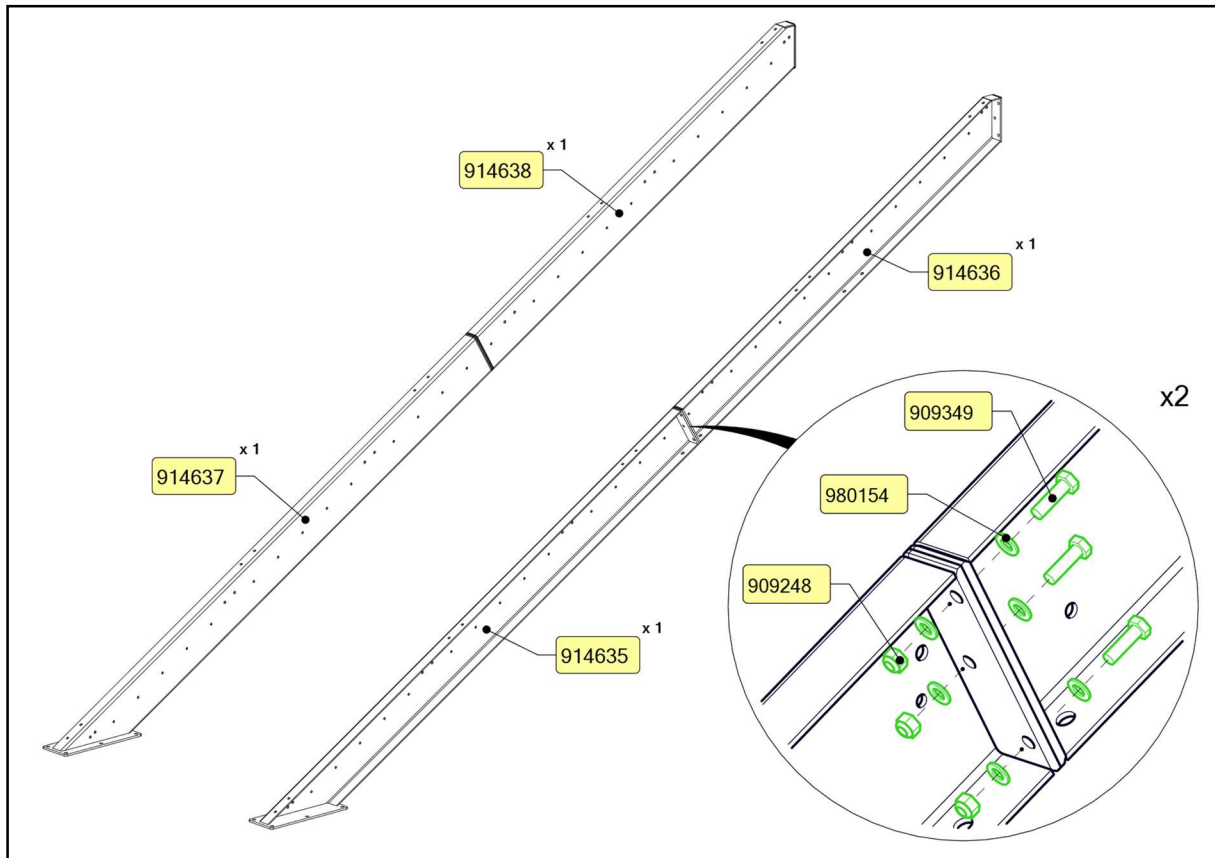

**SISU FITNESS STAIRS**

**RAMP (1 PC)**

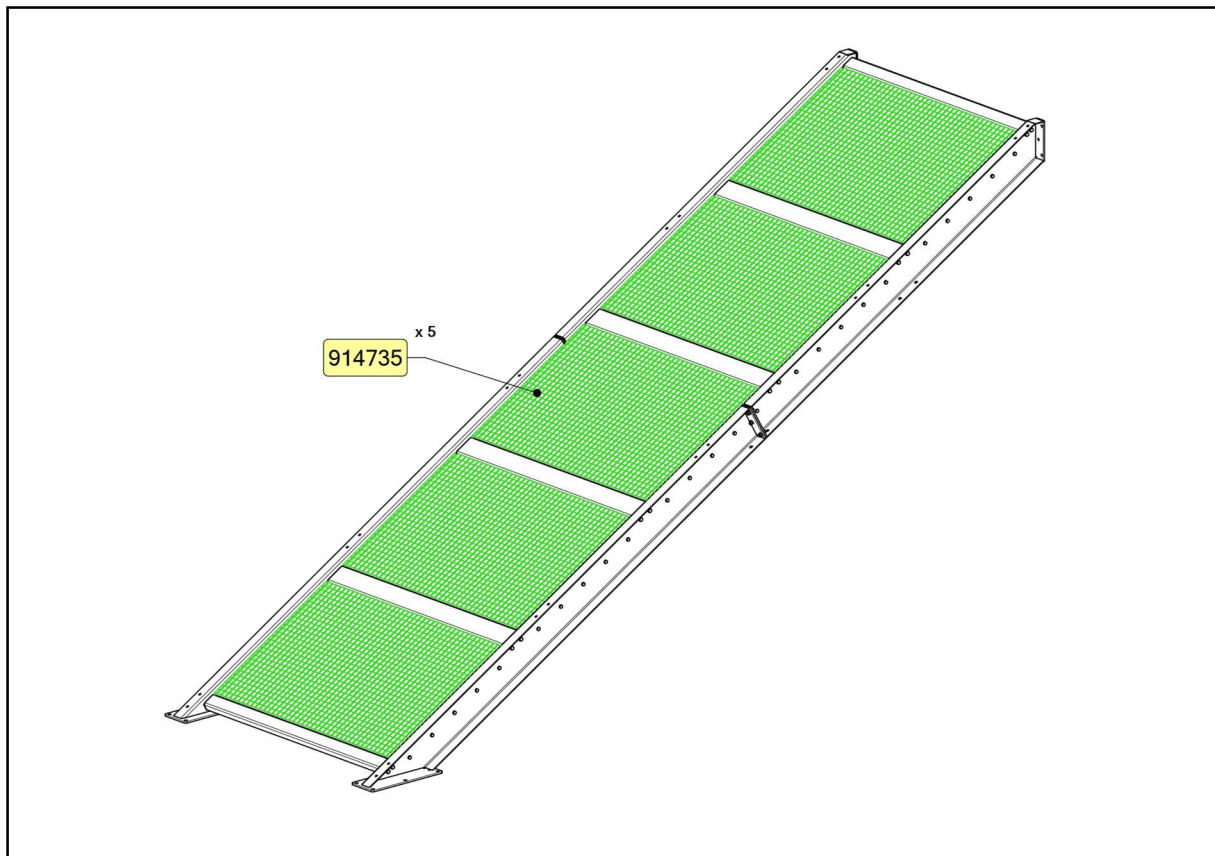
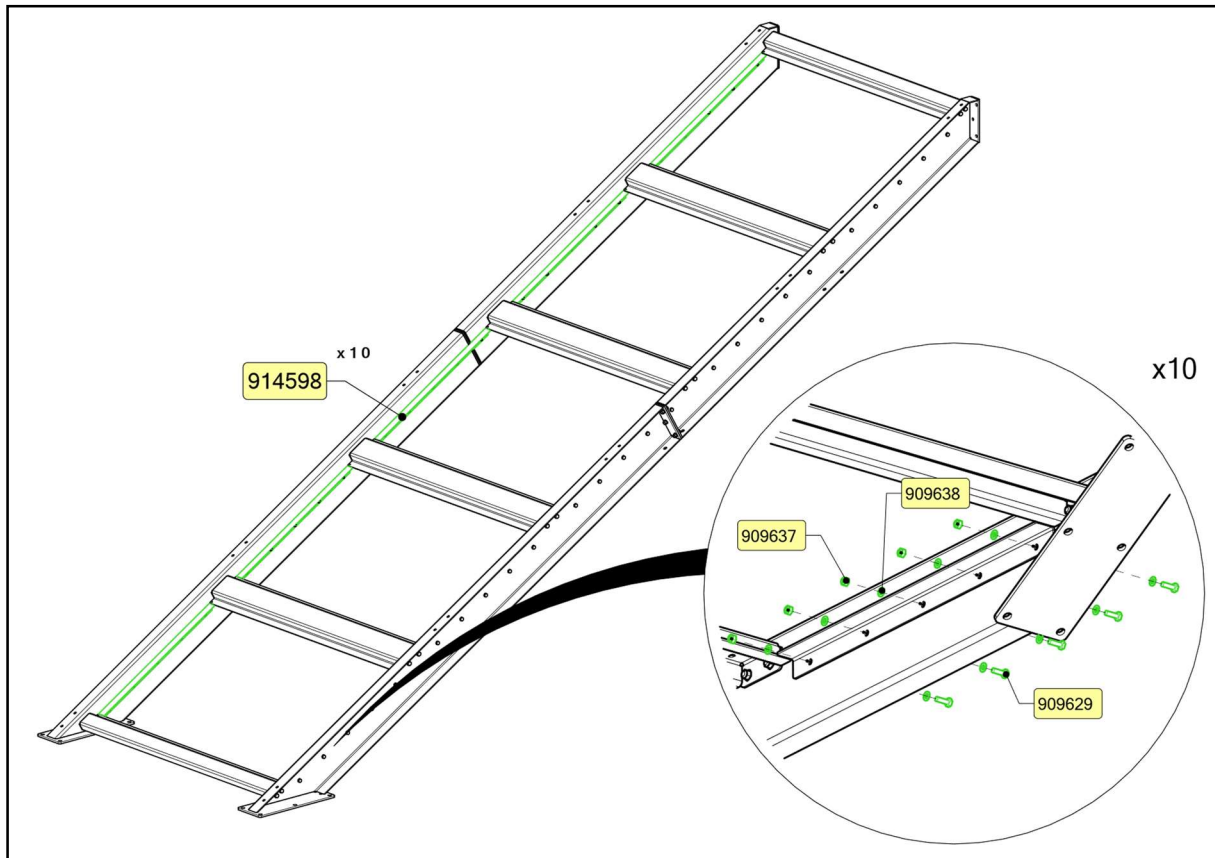

## SISU FITNESS STAIRS

### RAMP (1 PC)

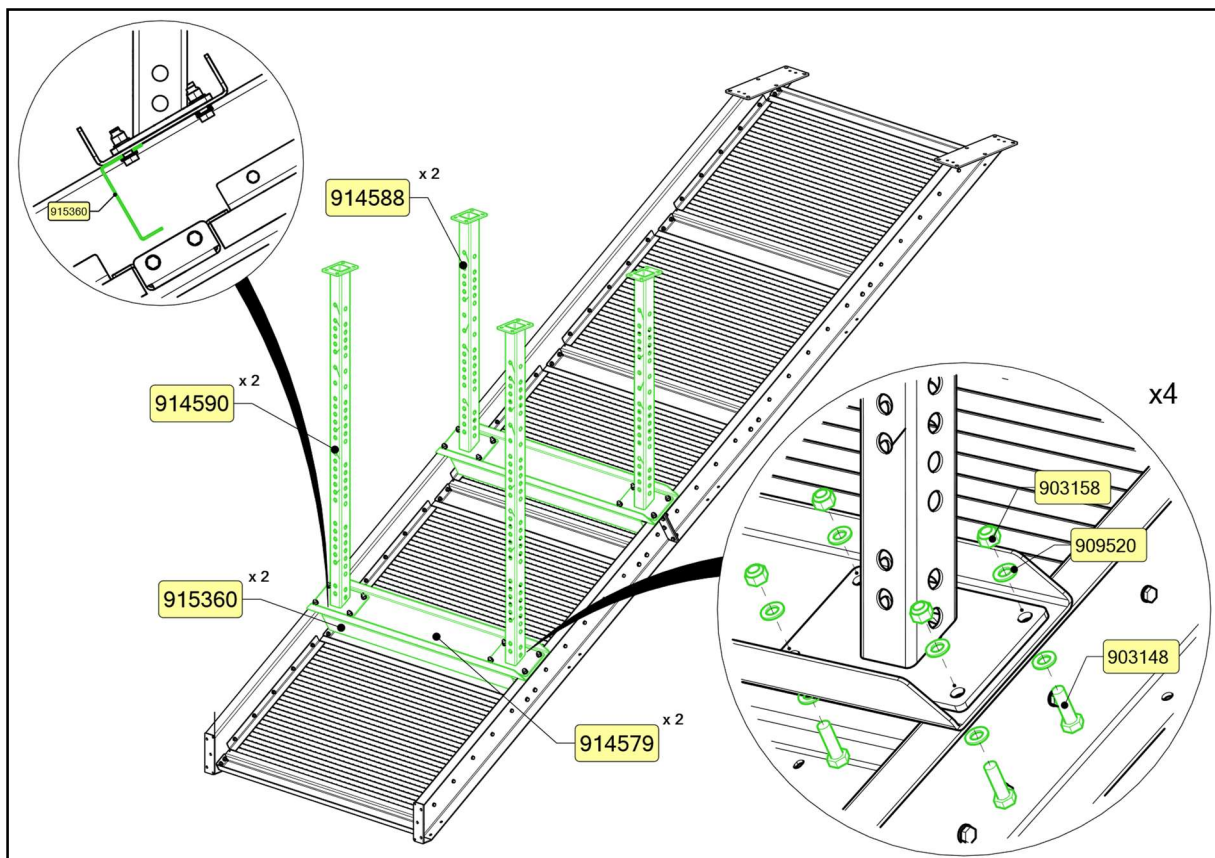
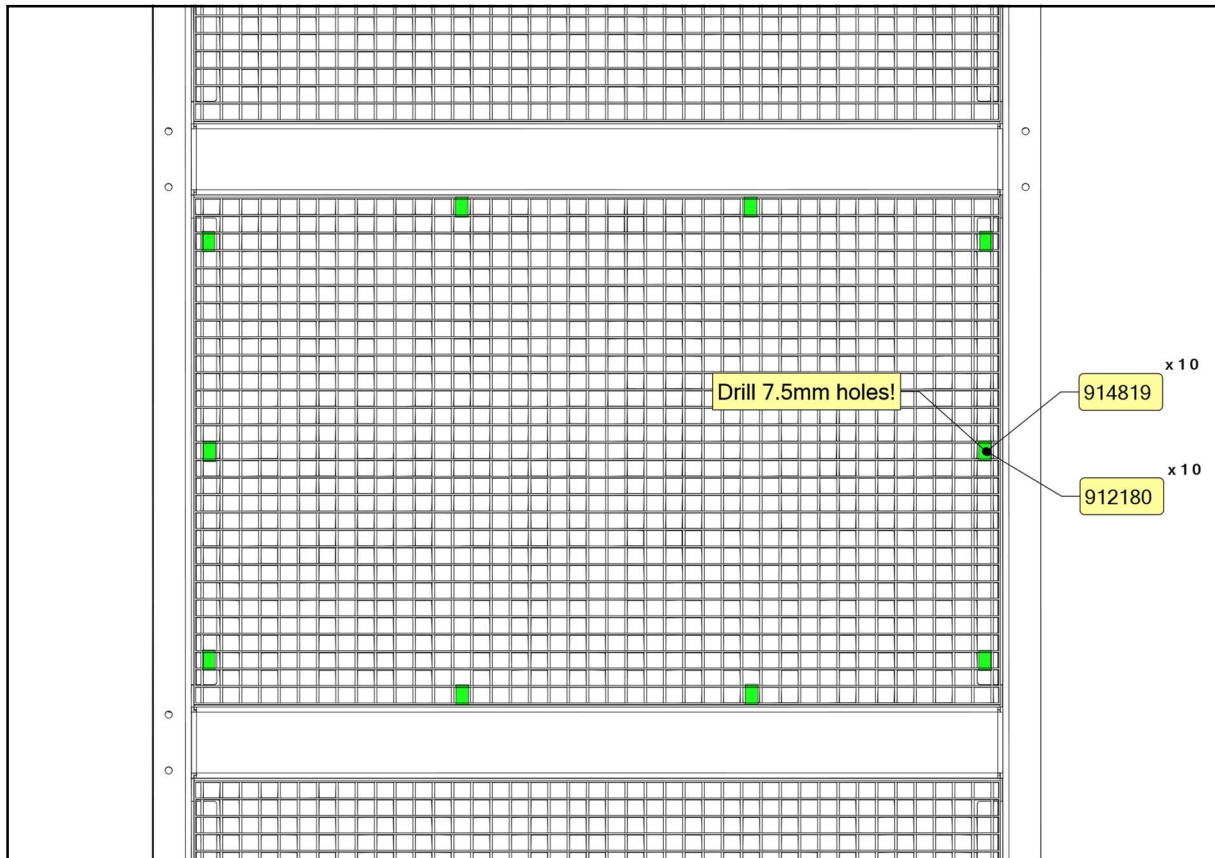

## SISU FITNESS STAIRS

### RAMP (1 PC)

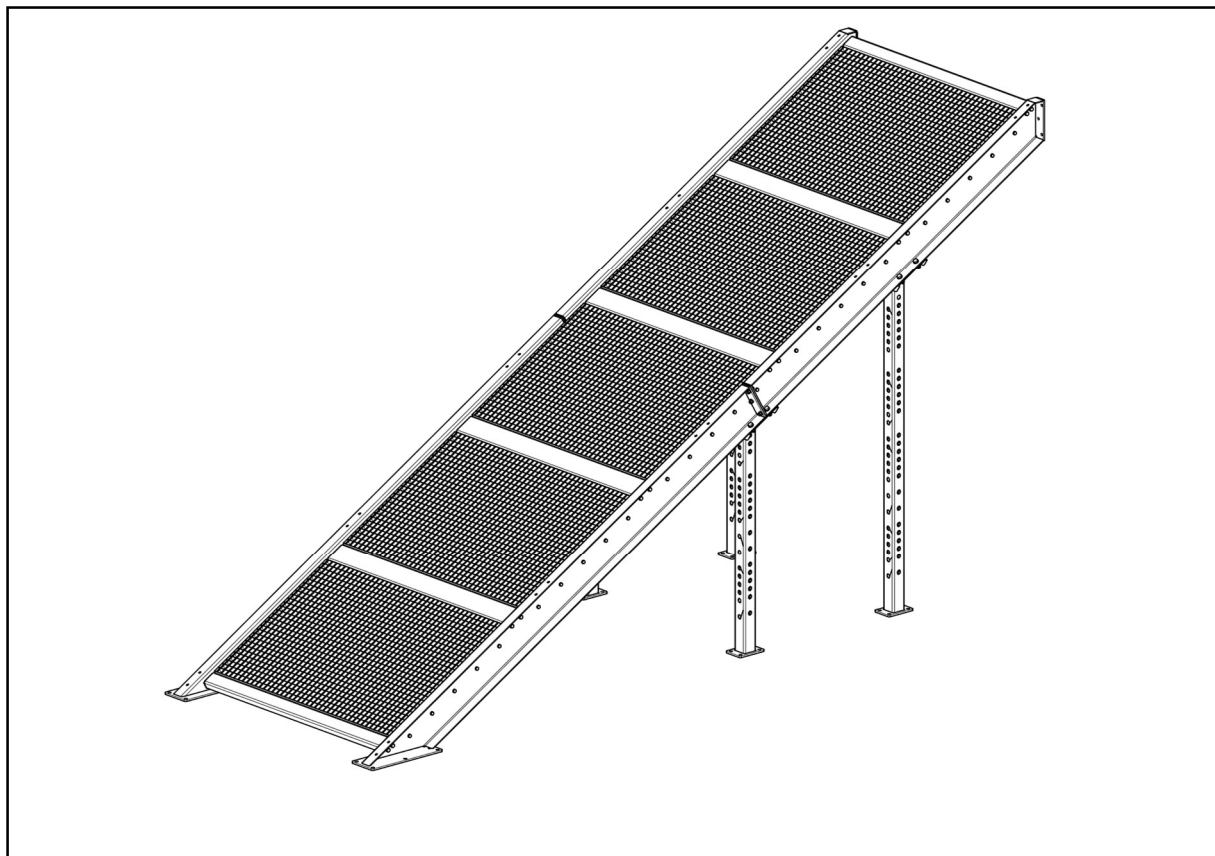
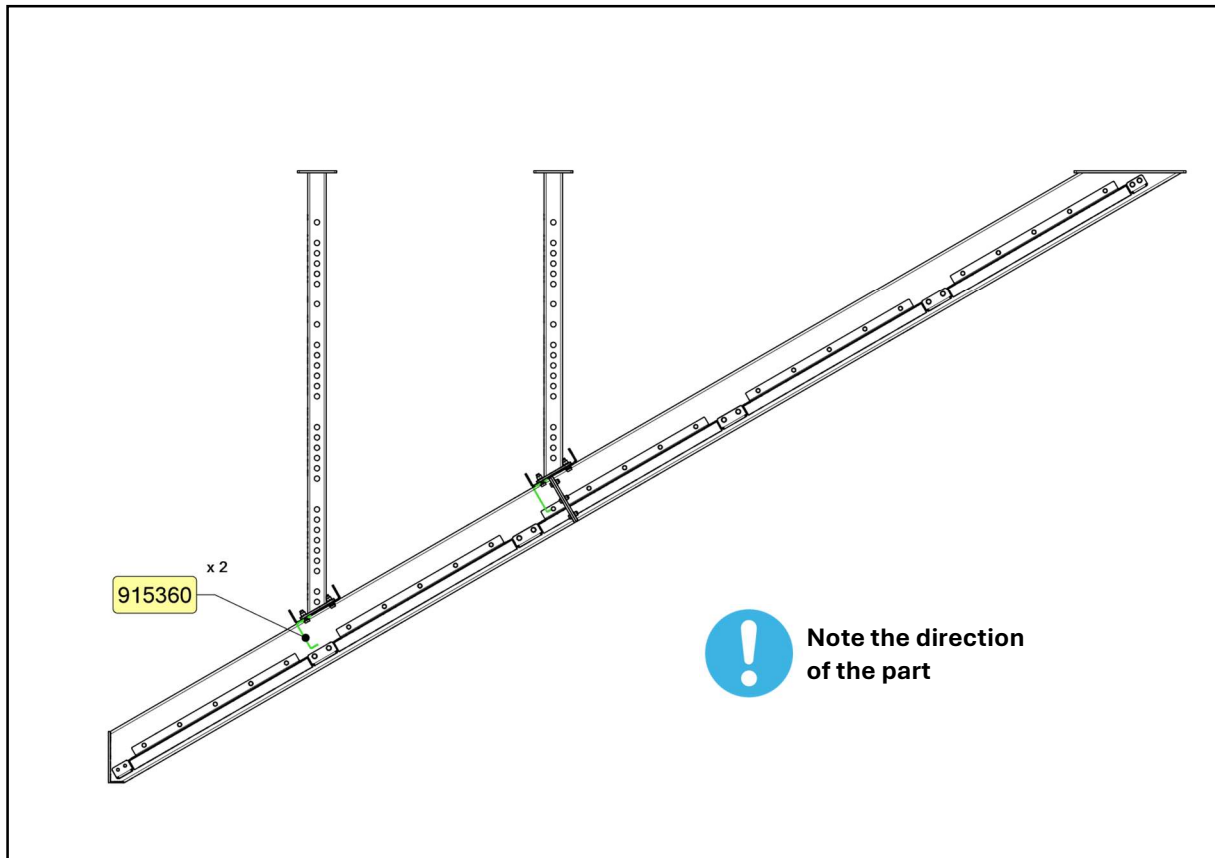

## SISU FITNESS STAIRS

### FLOOR-1 (1 PC)

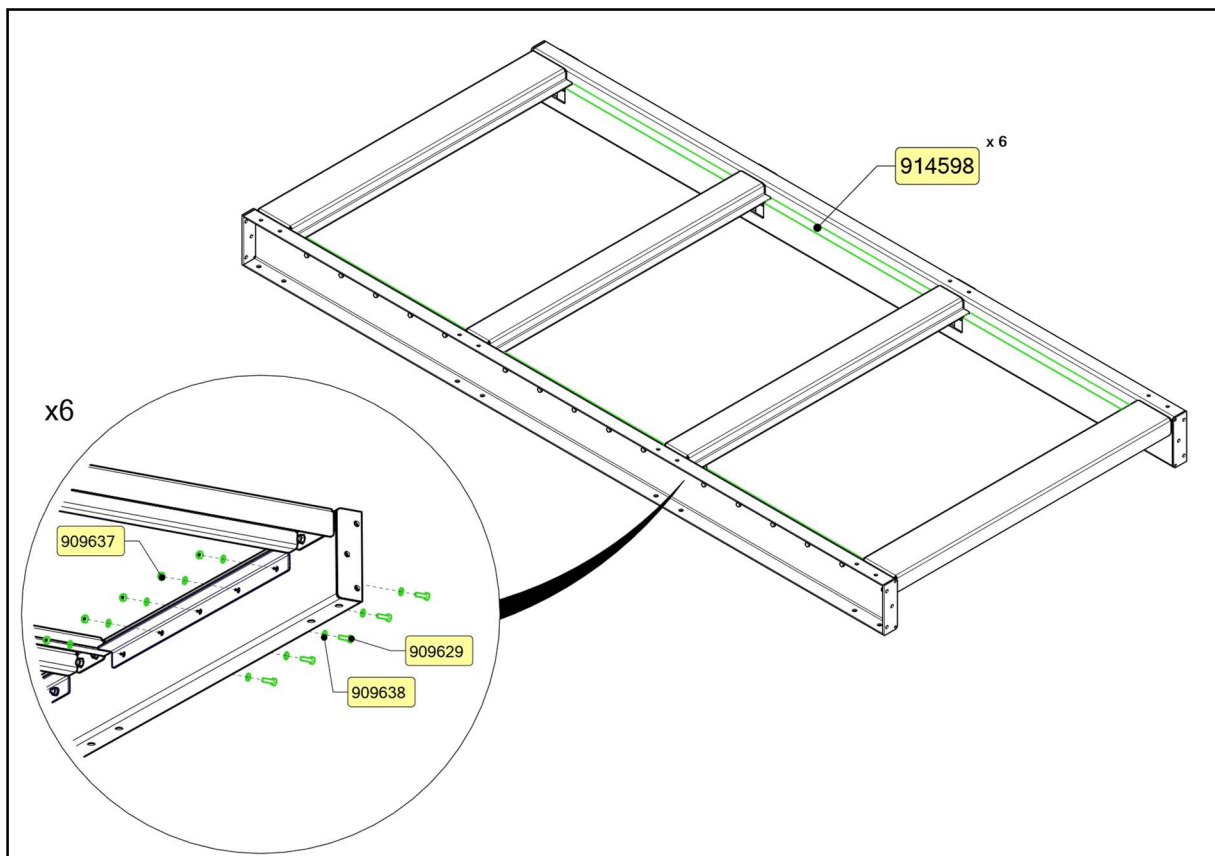
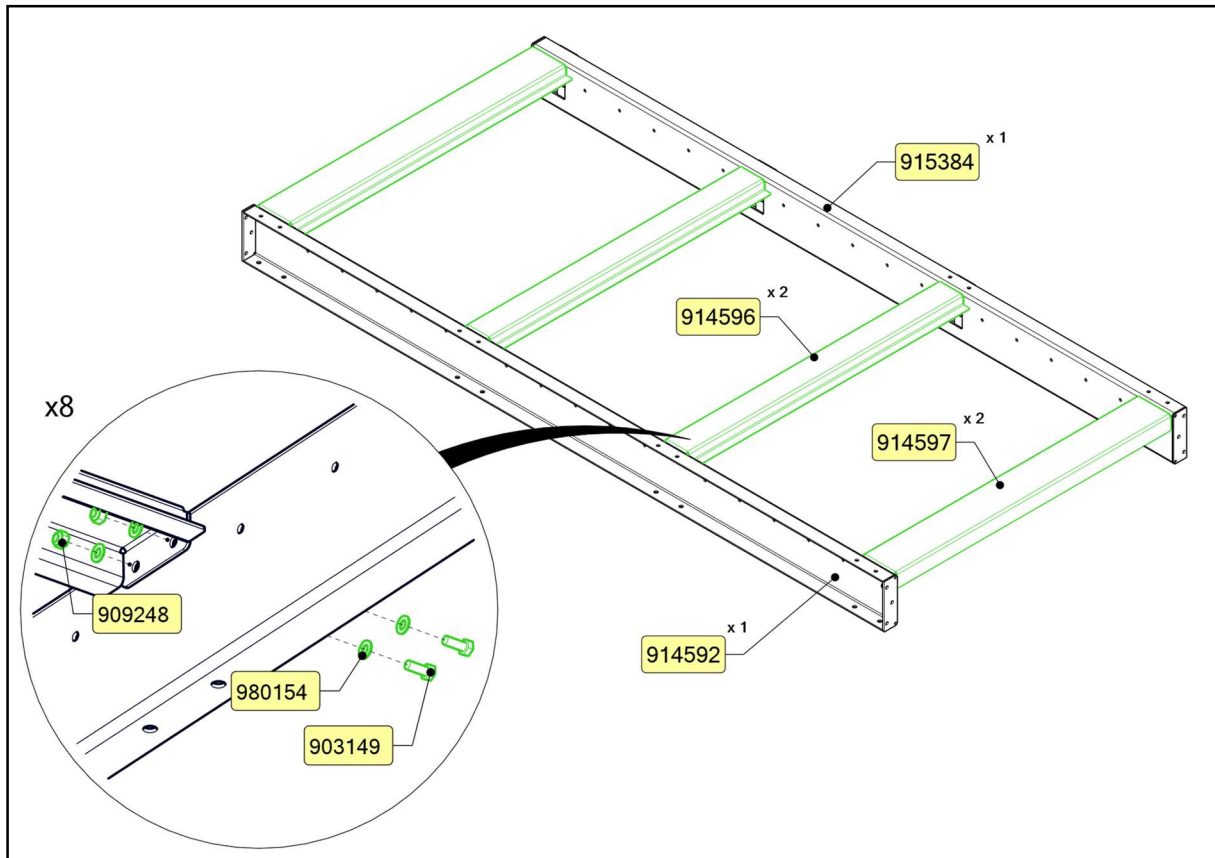

## SISU FITNESS STAIRS

### FLOOR-1 (1 PC)

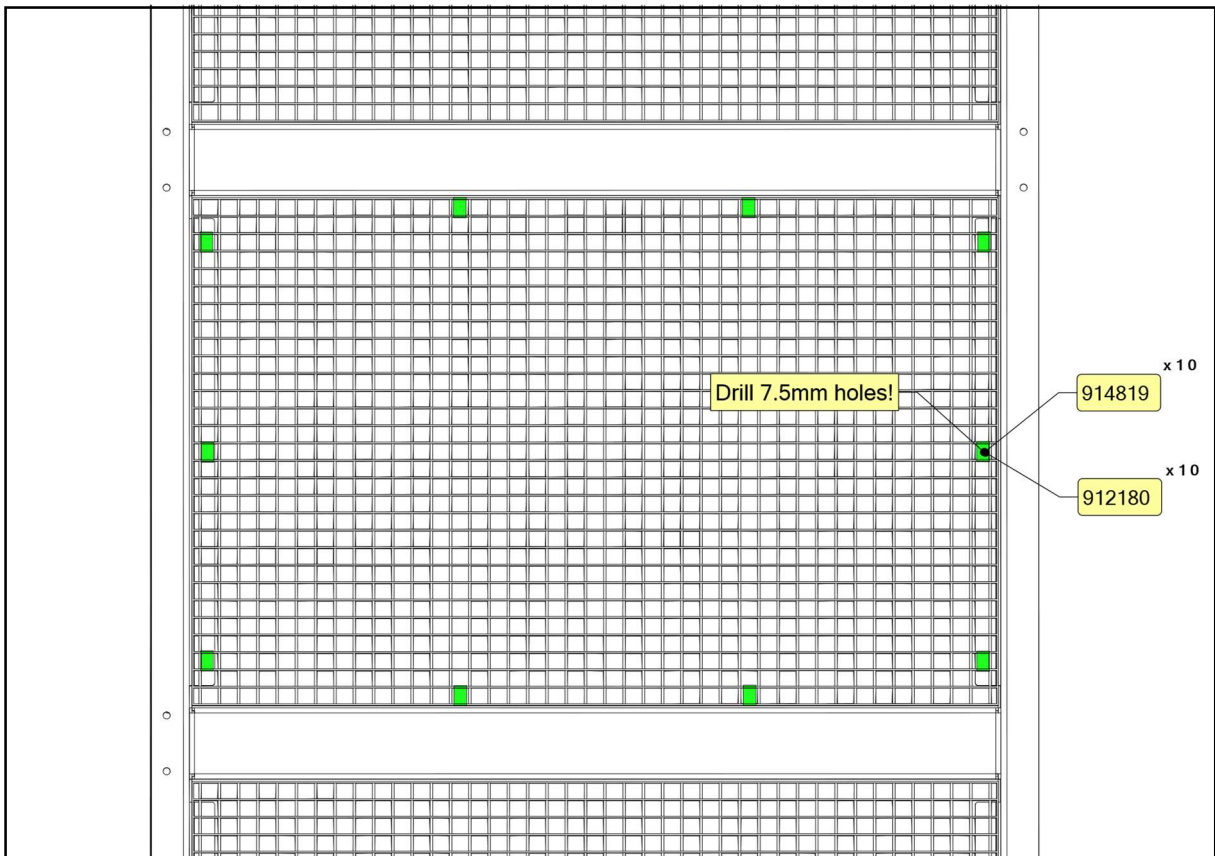
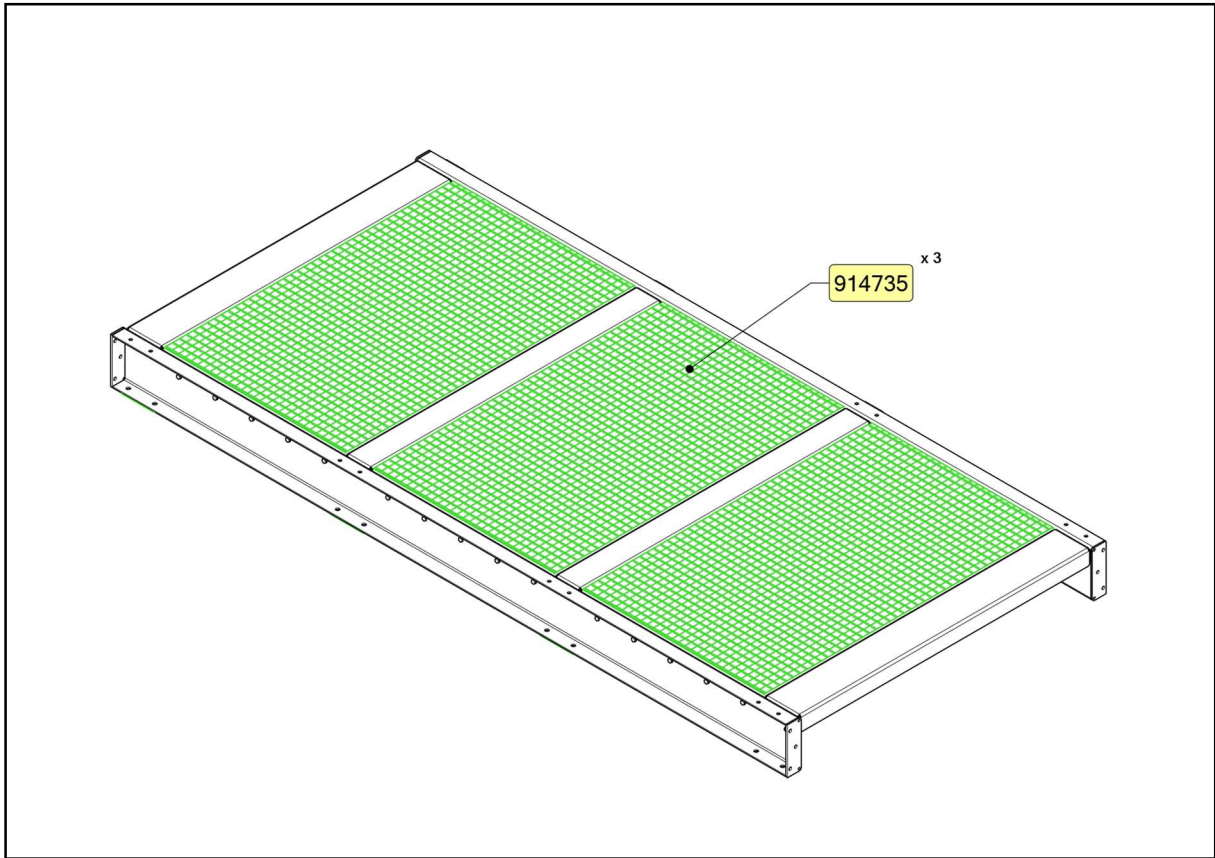

## SISU FITNESS STAIRS

### FLOOR-1 (1 PC)

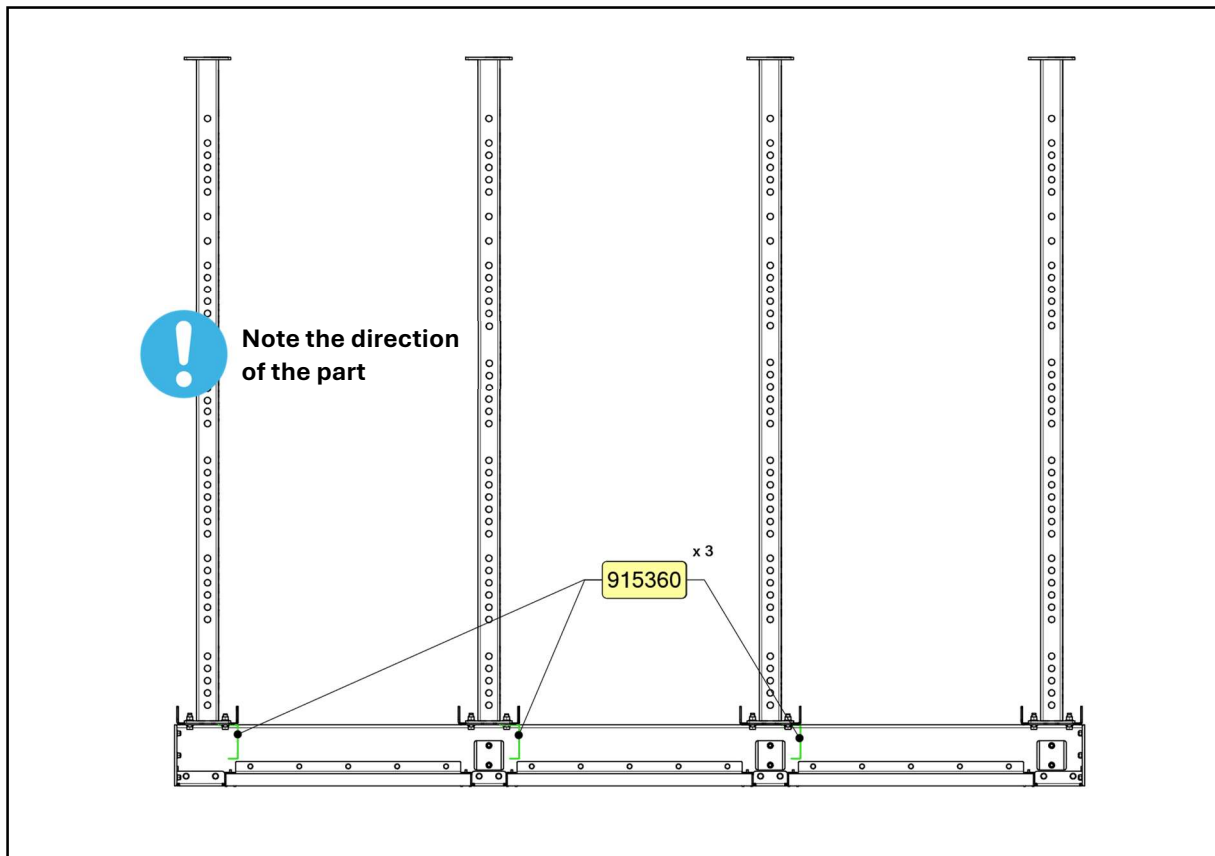
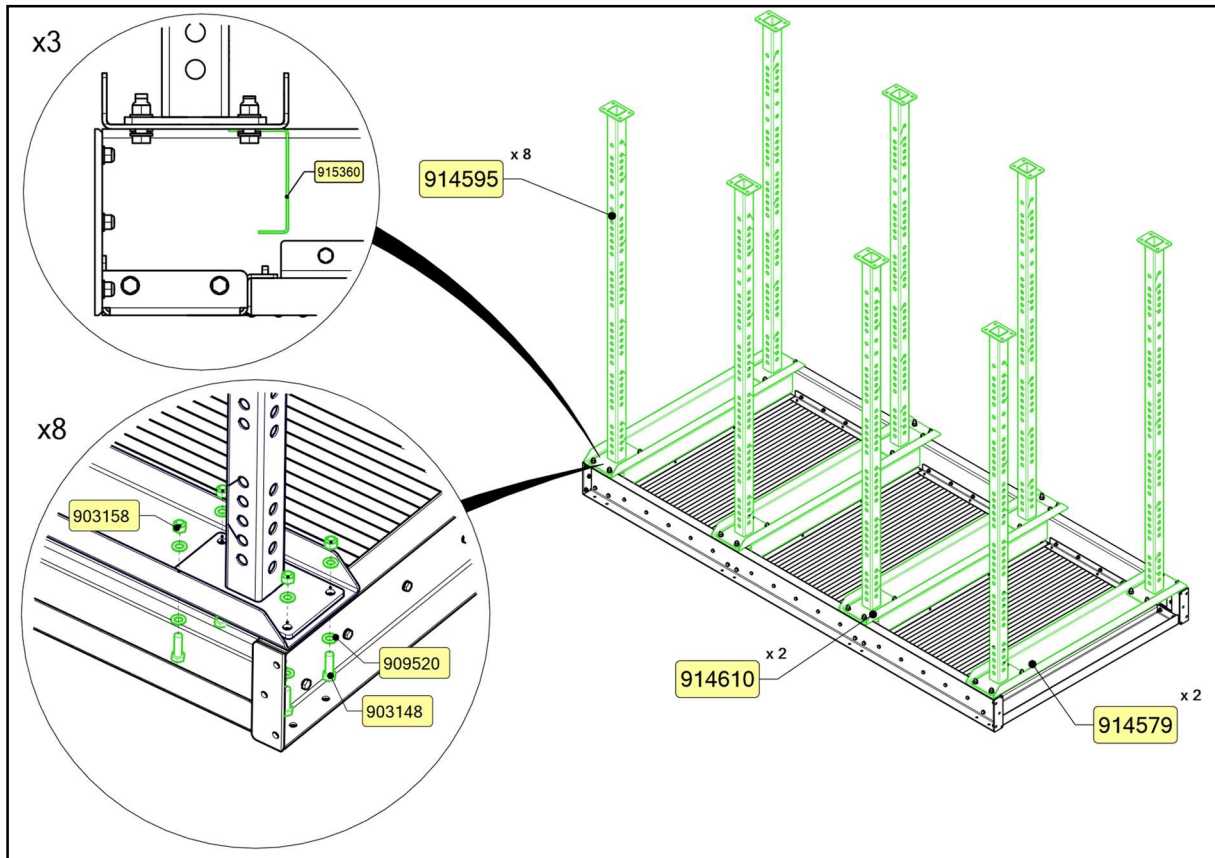

**SISU FITNESS STAIRS**

**FLOOR-1 (1 PC)**

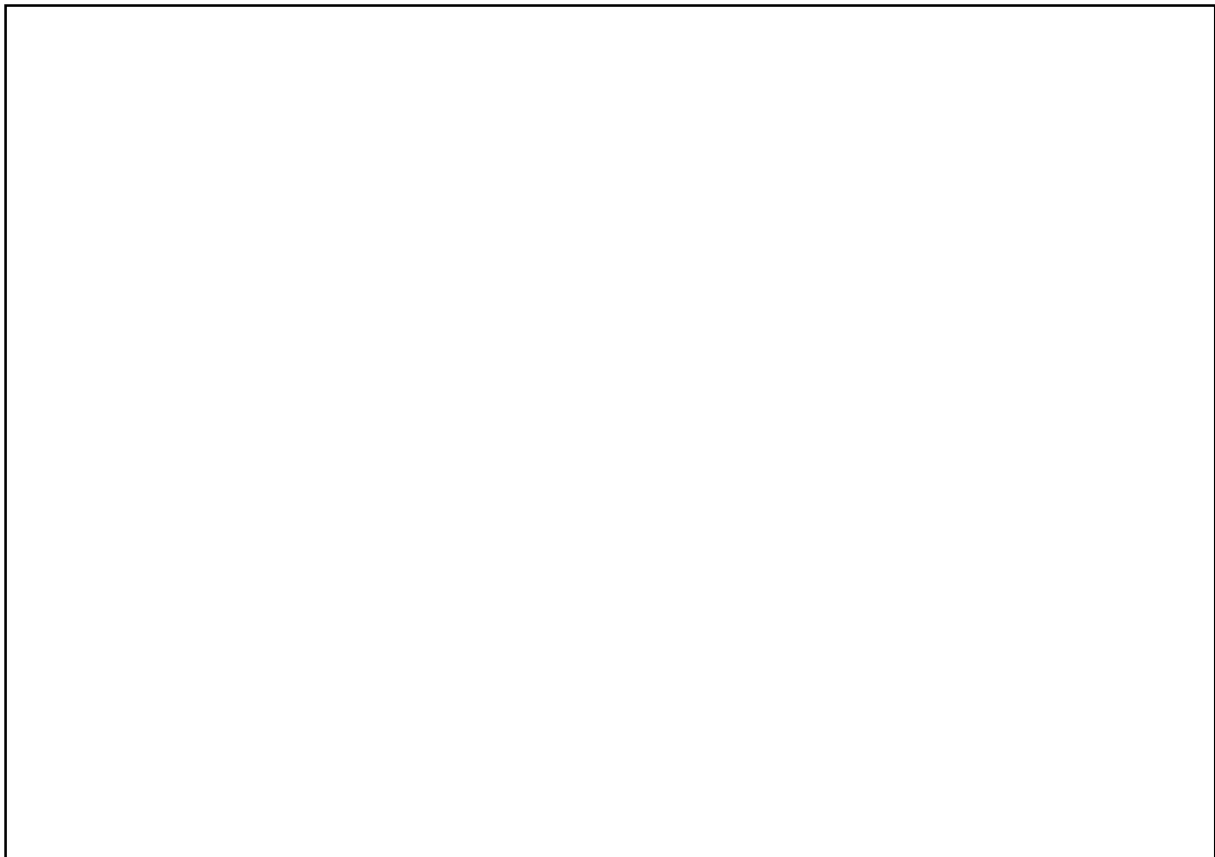
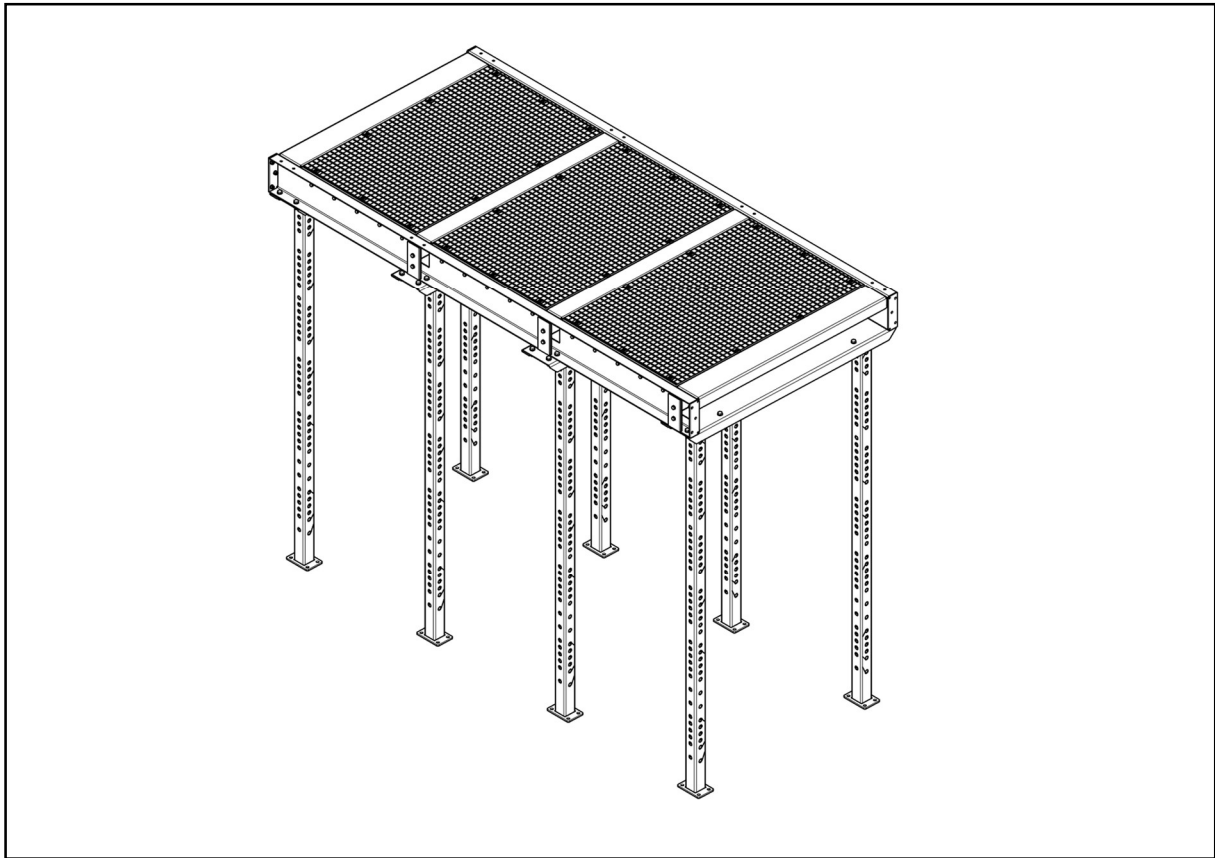

## SISU FITNESS STAIRS

### FLOOR-2 (1 PC)

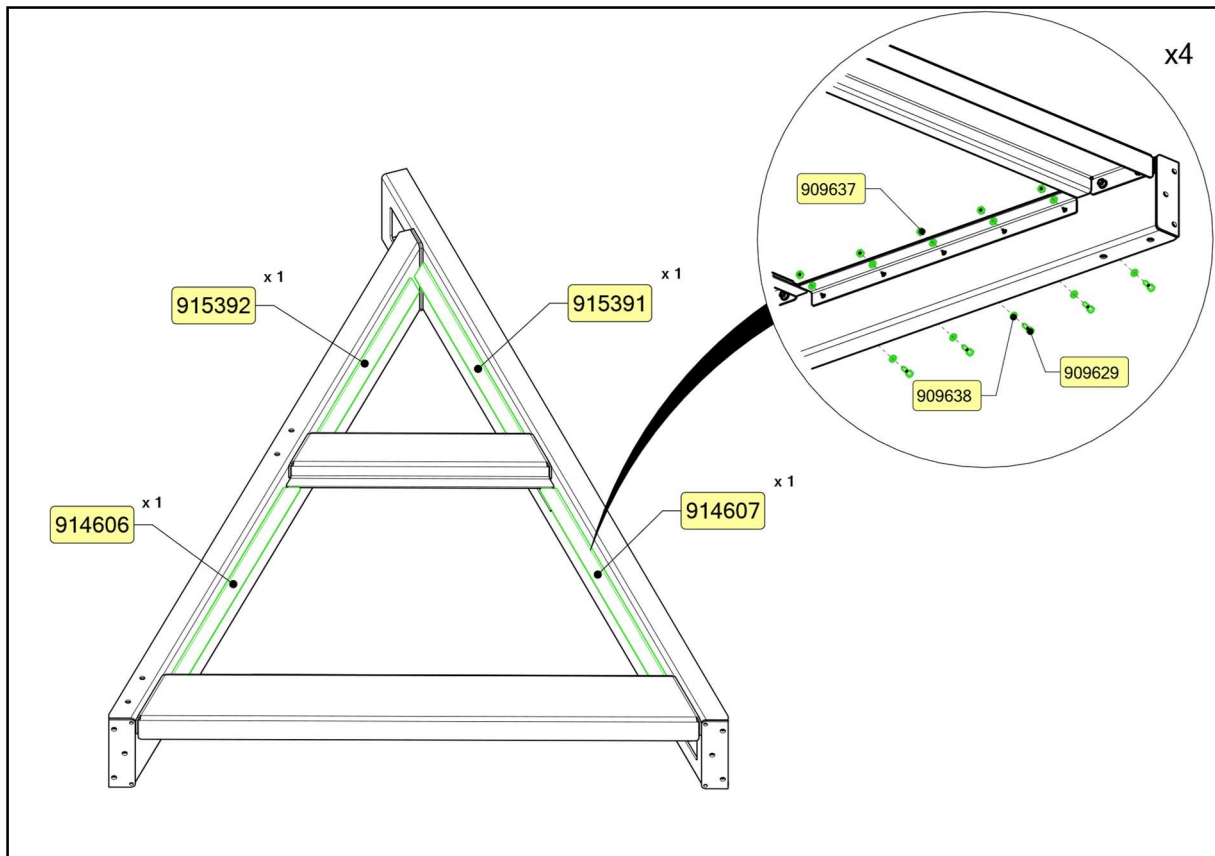
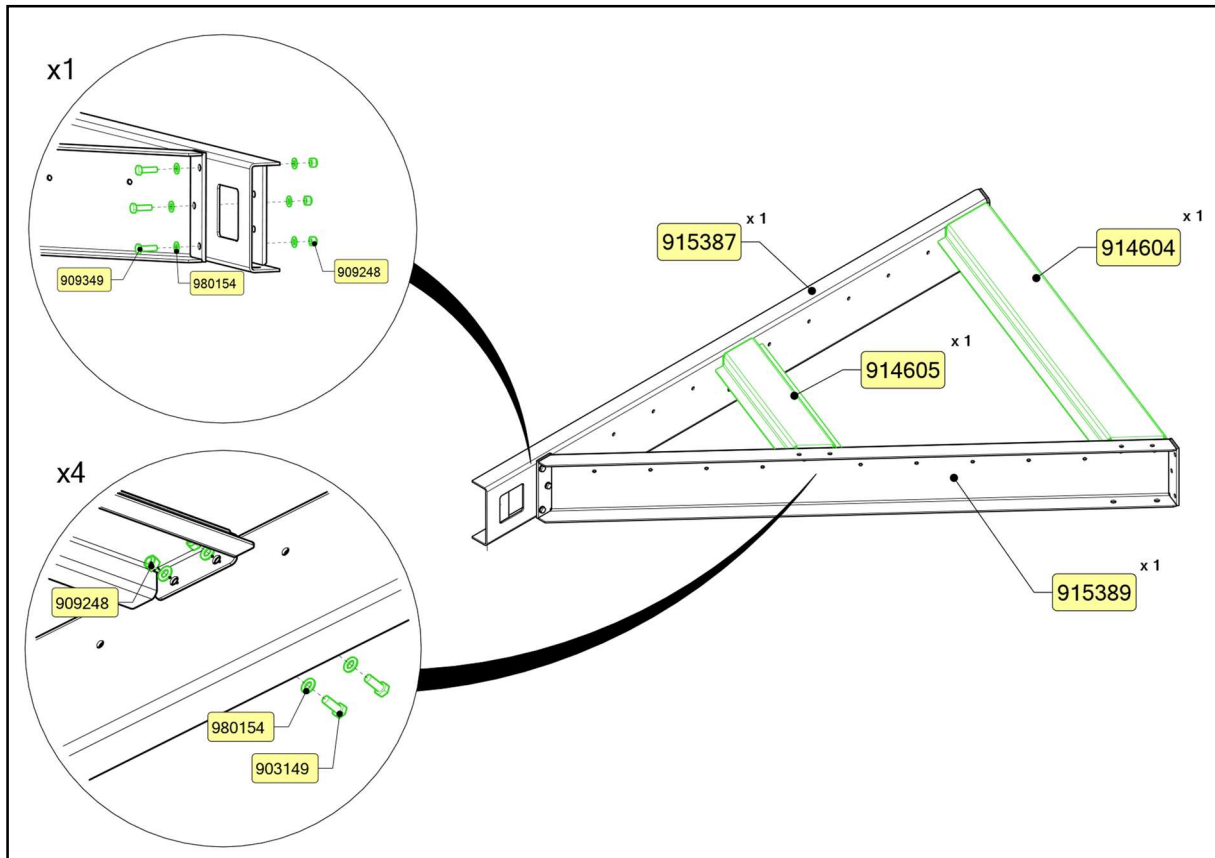

## SISU FITNESS STAIRS

### FLOOR-2 (1 PC)

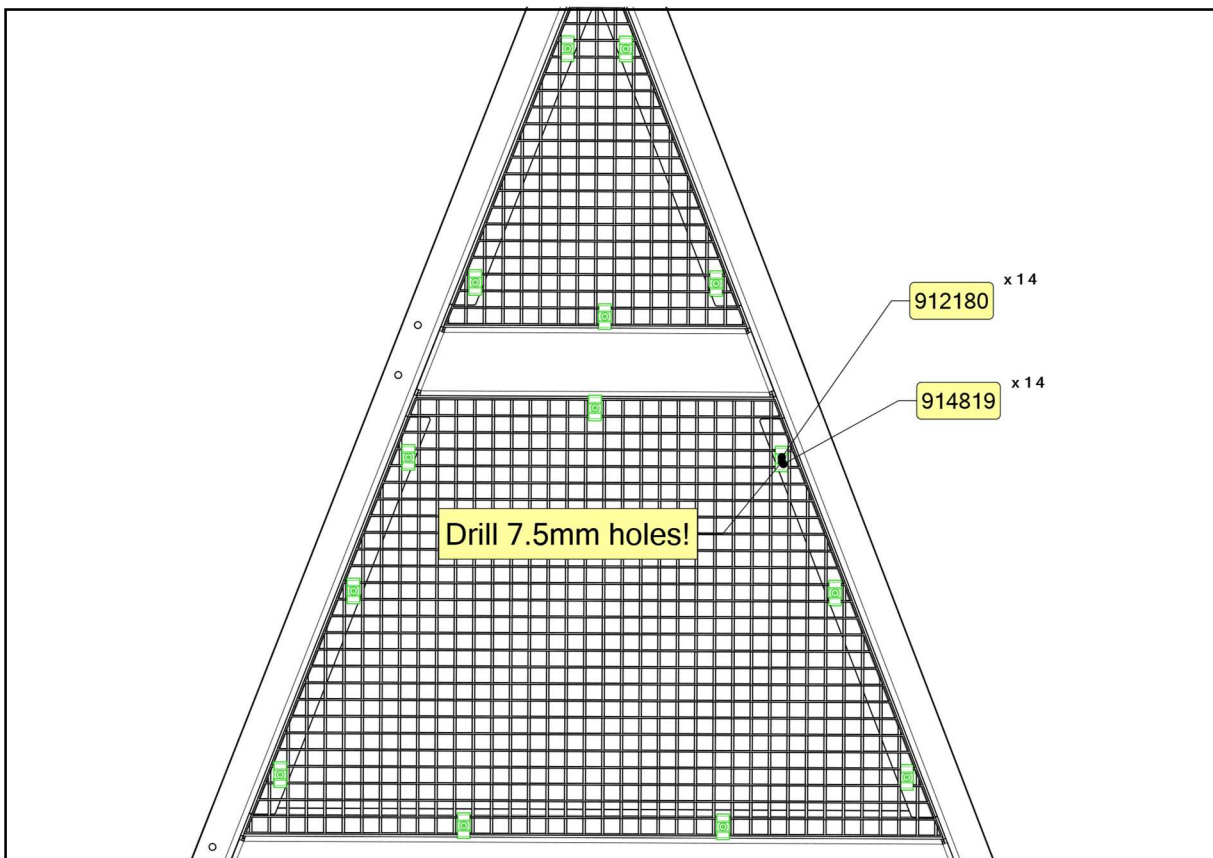
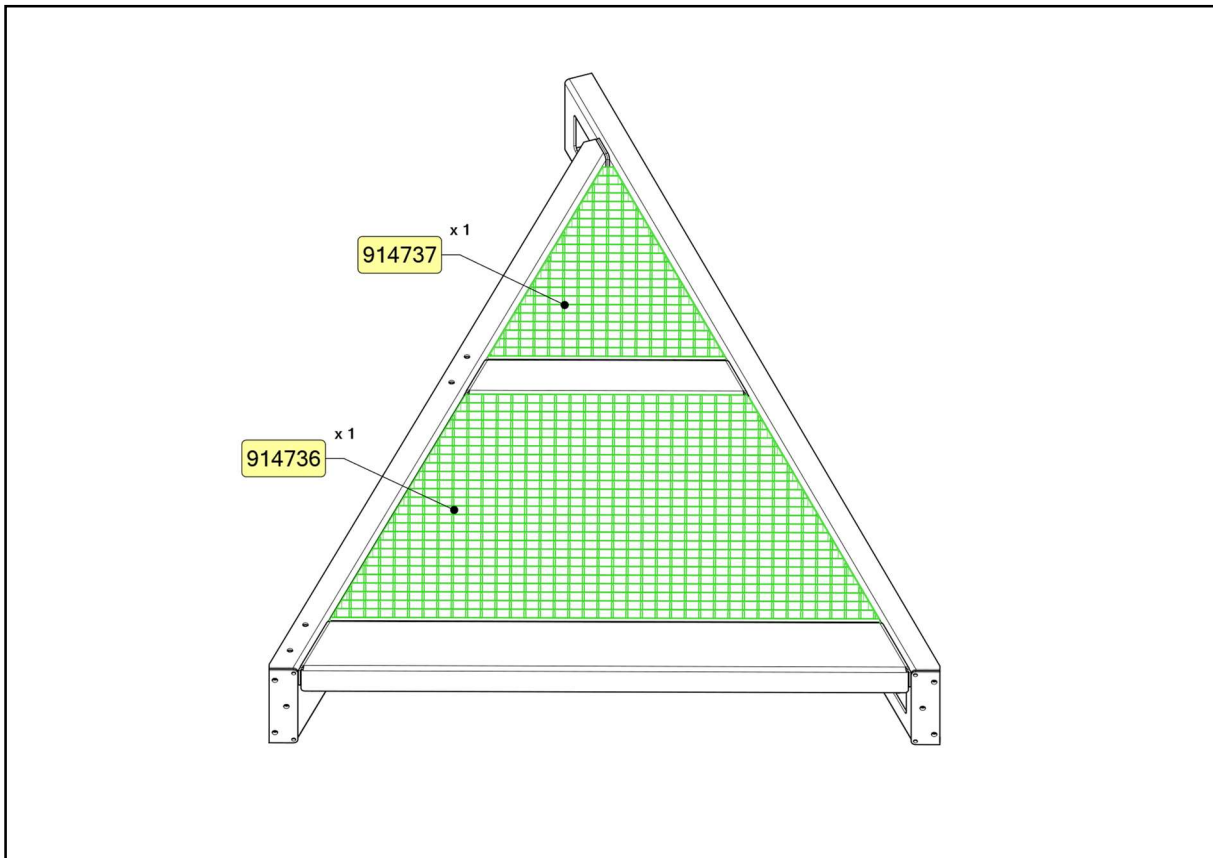

## SISU FITNESS STAIRS

### FLOOR-2 (1 PC)

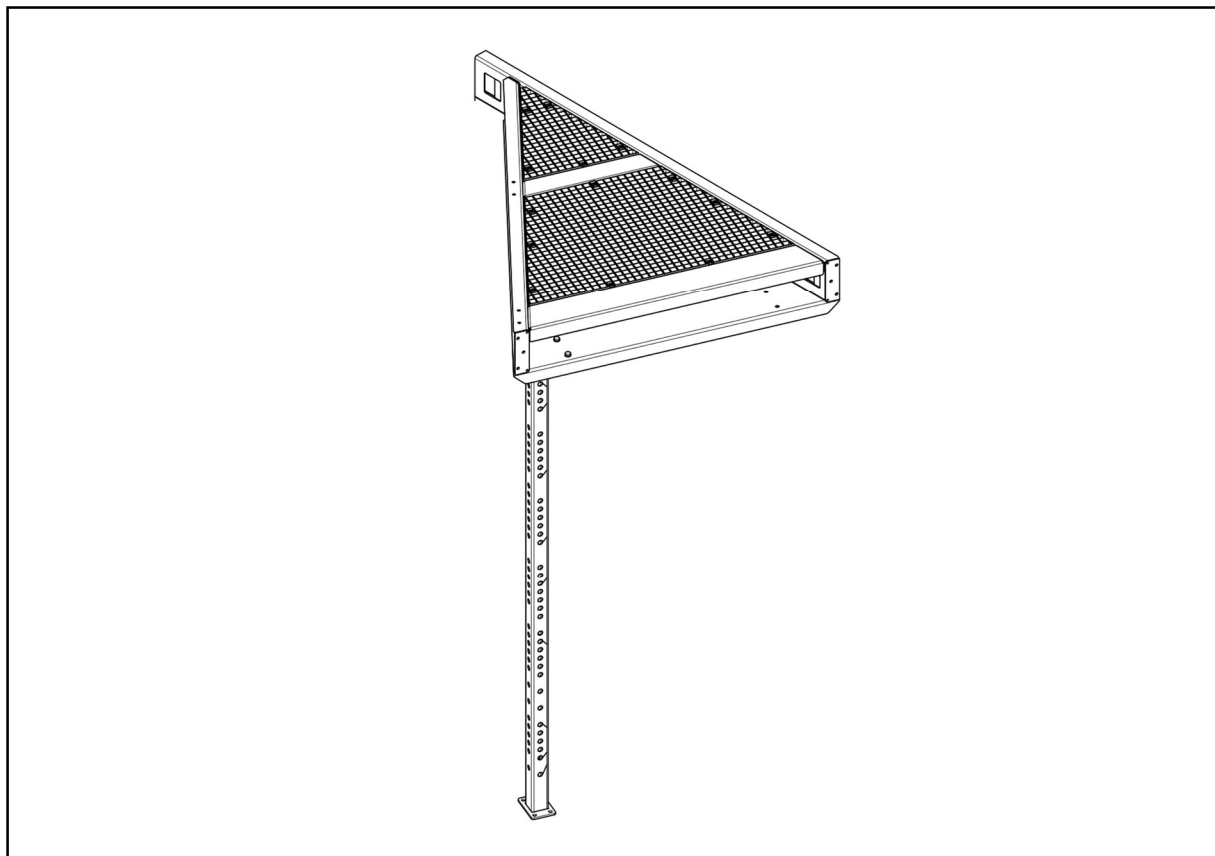
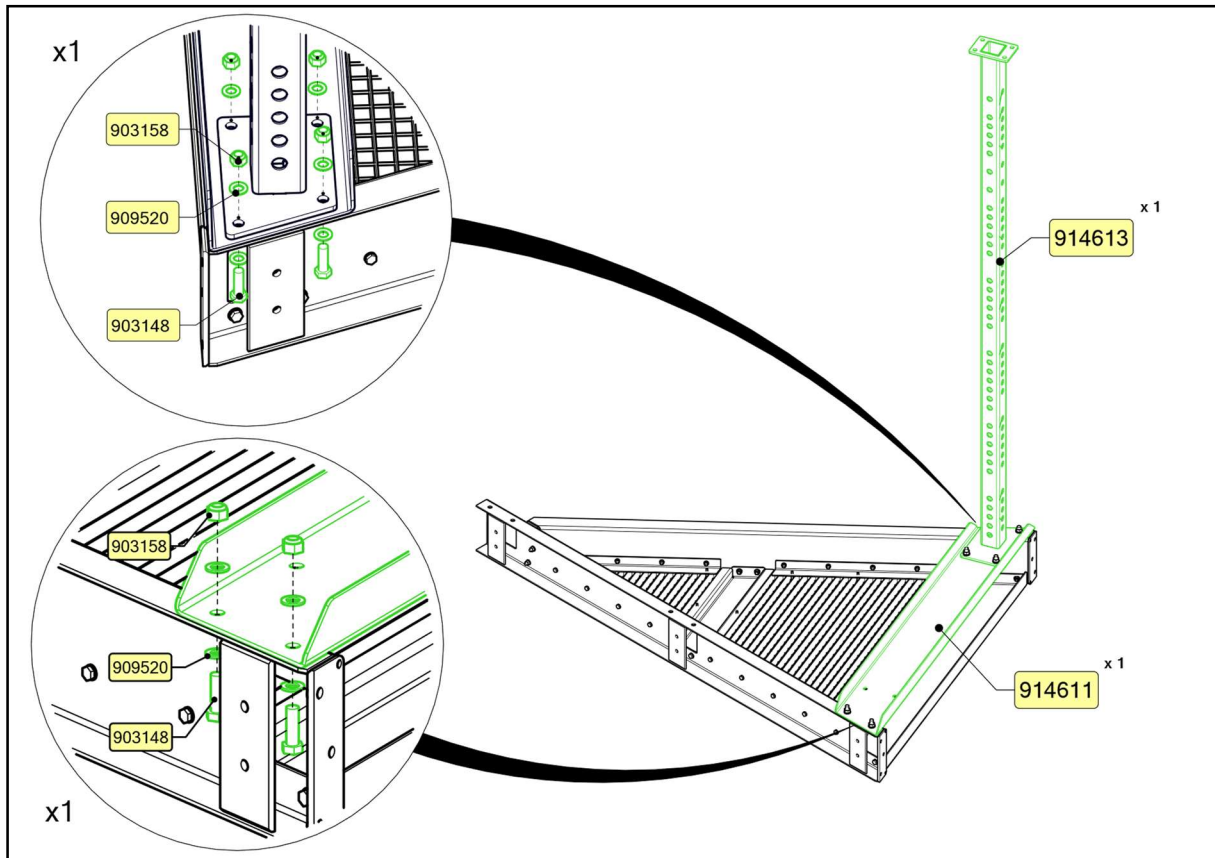

## SISU FITNESS STAIRS

### ASSEMBLY

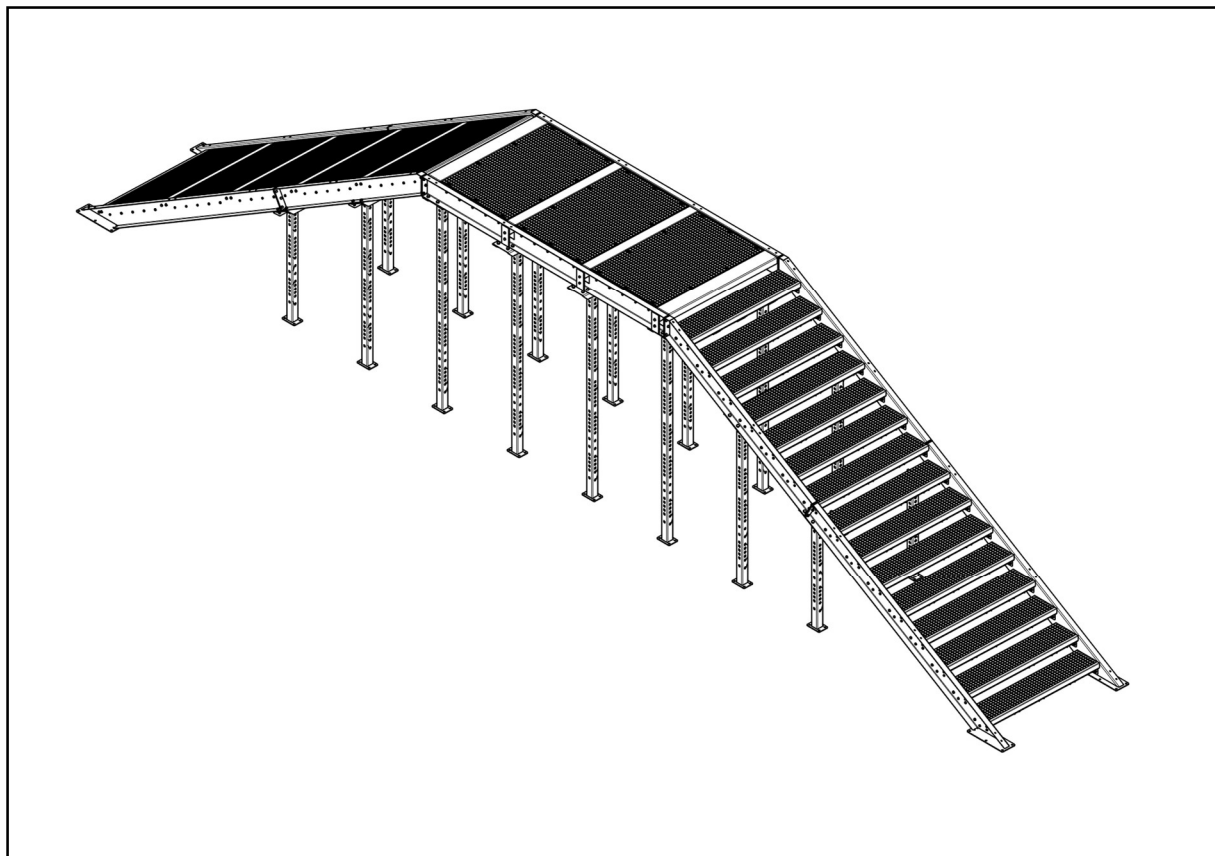
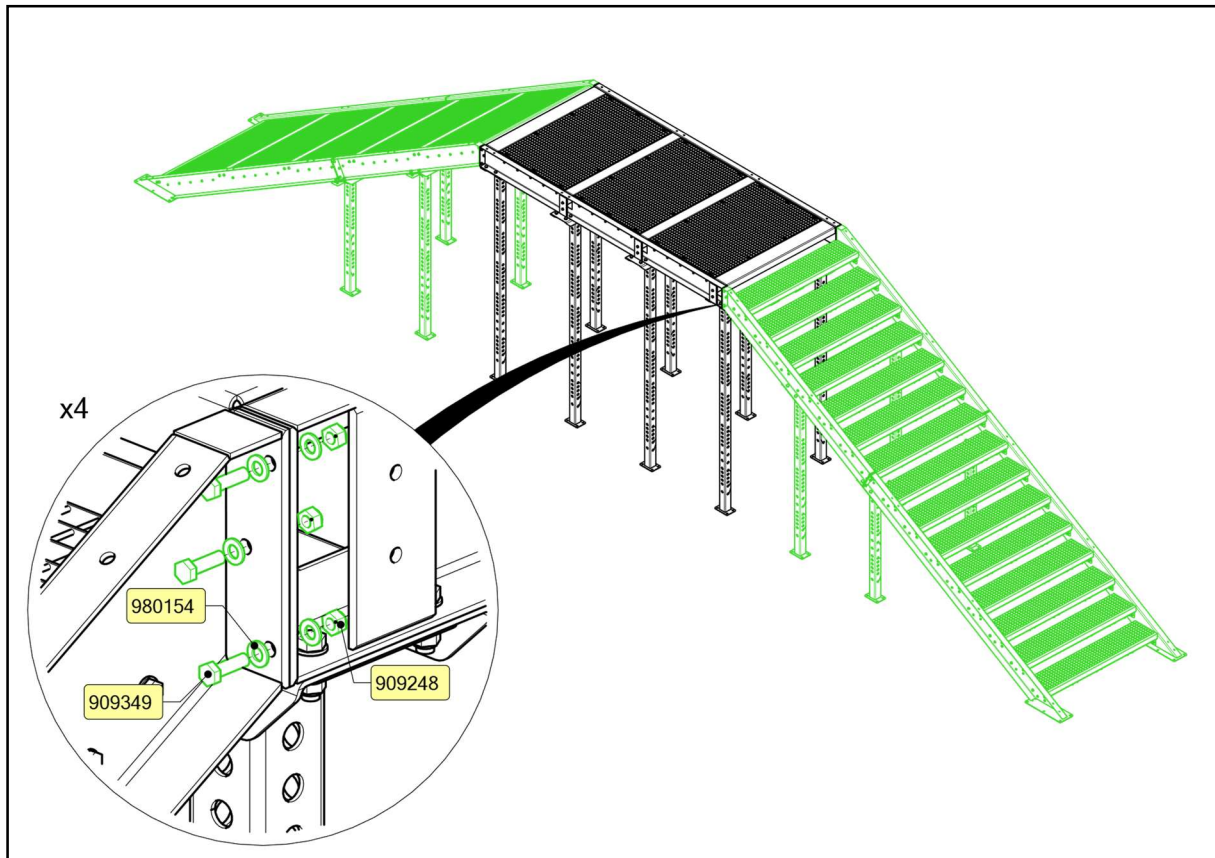

## SISU FITNESS STAIRS

### ASSEMBLY

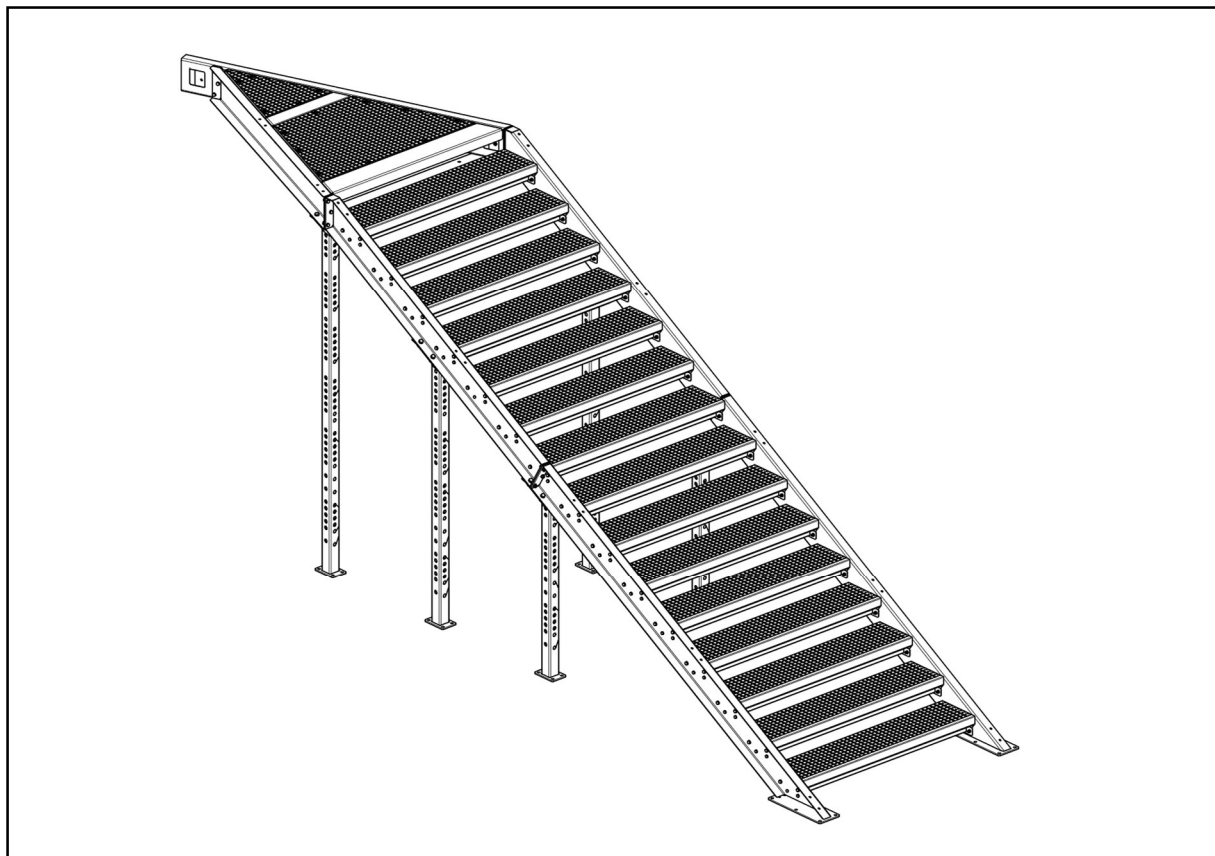
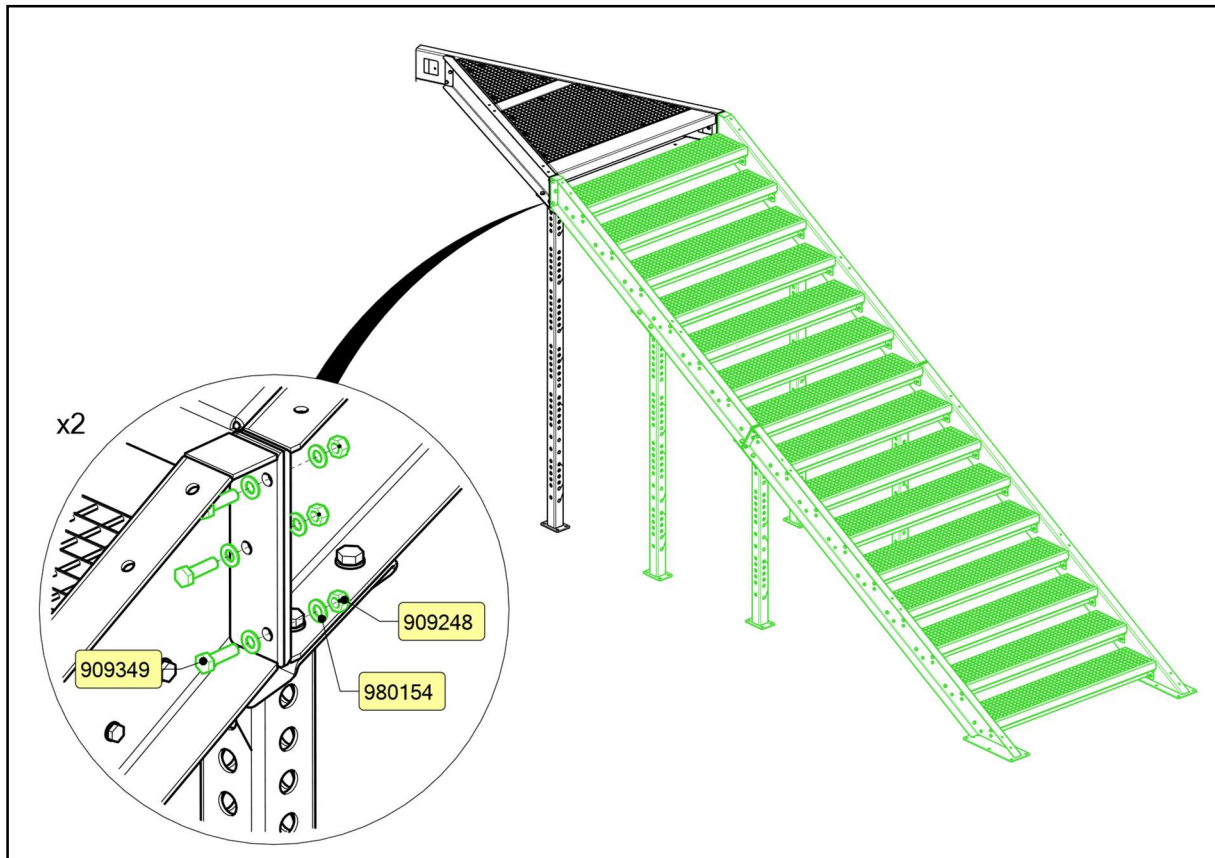

## SISU FITNESS STAIRS

### ASSEMBLY

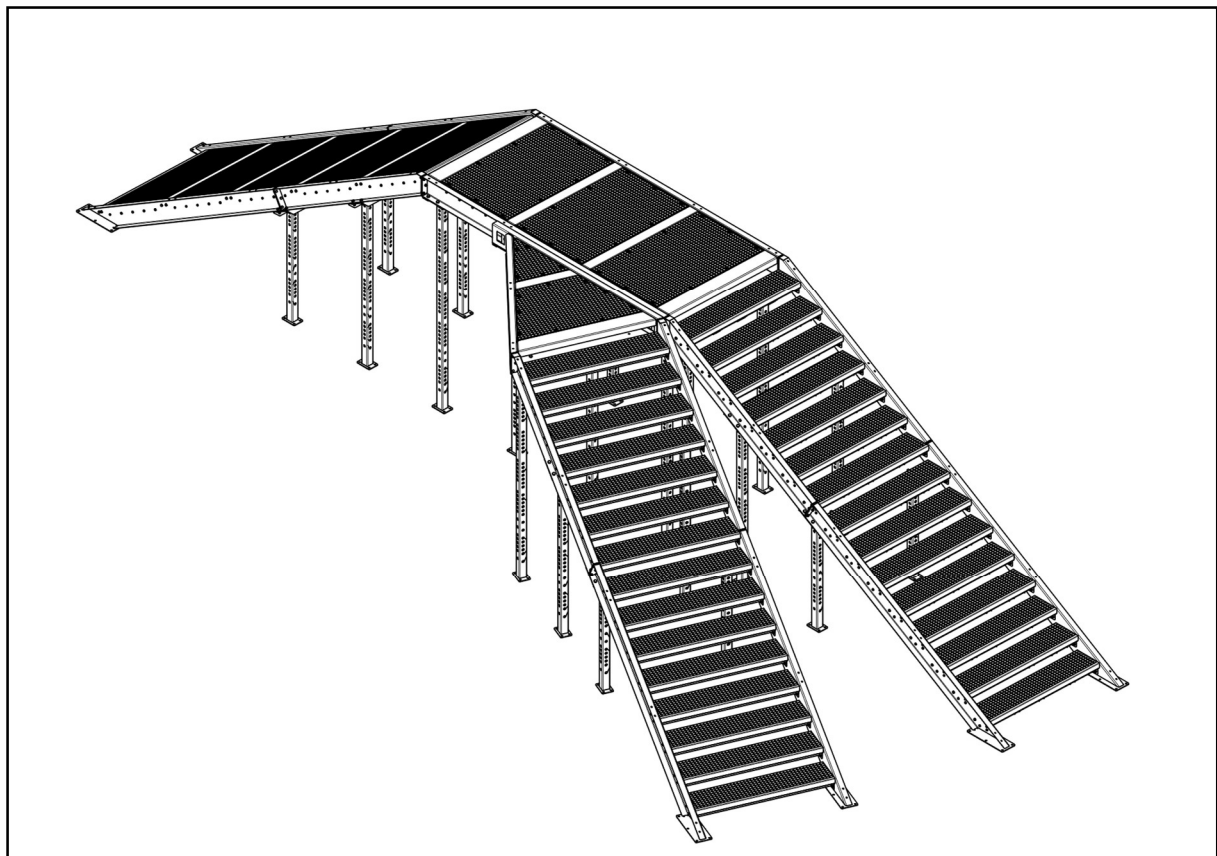
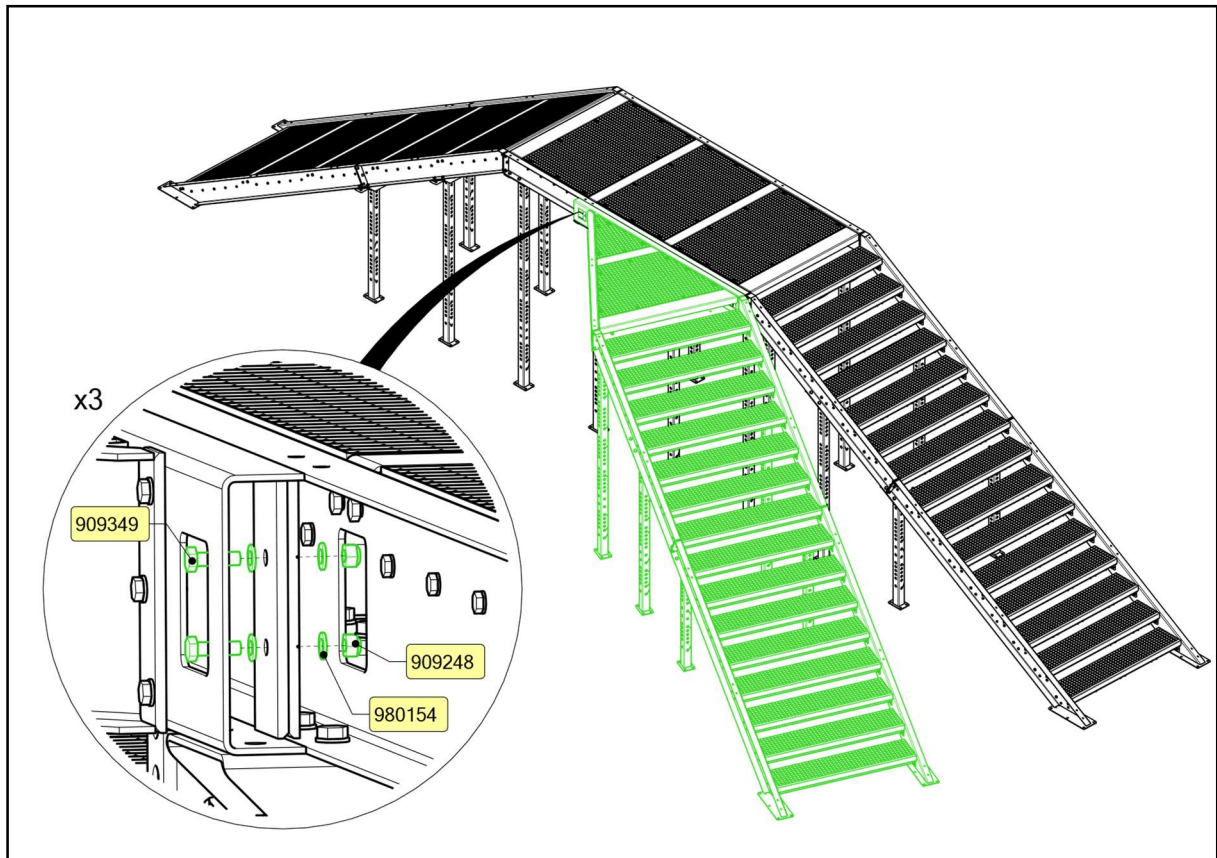

## SISU FITNESS STAIRS

### HANDRAIL-1 (1 PC)

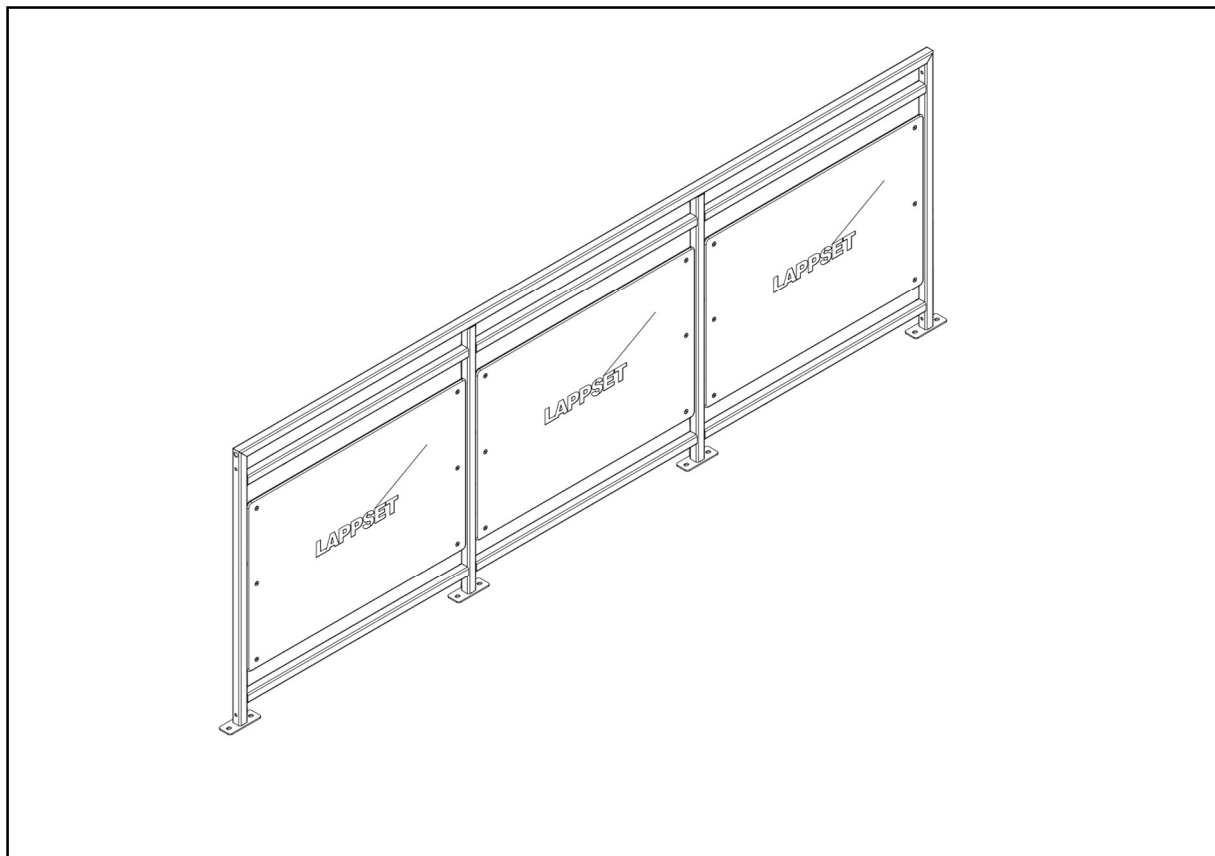
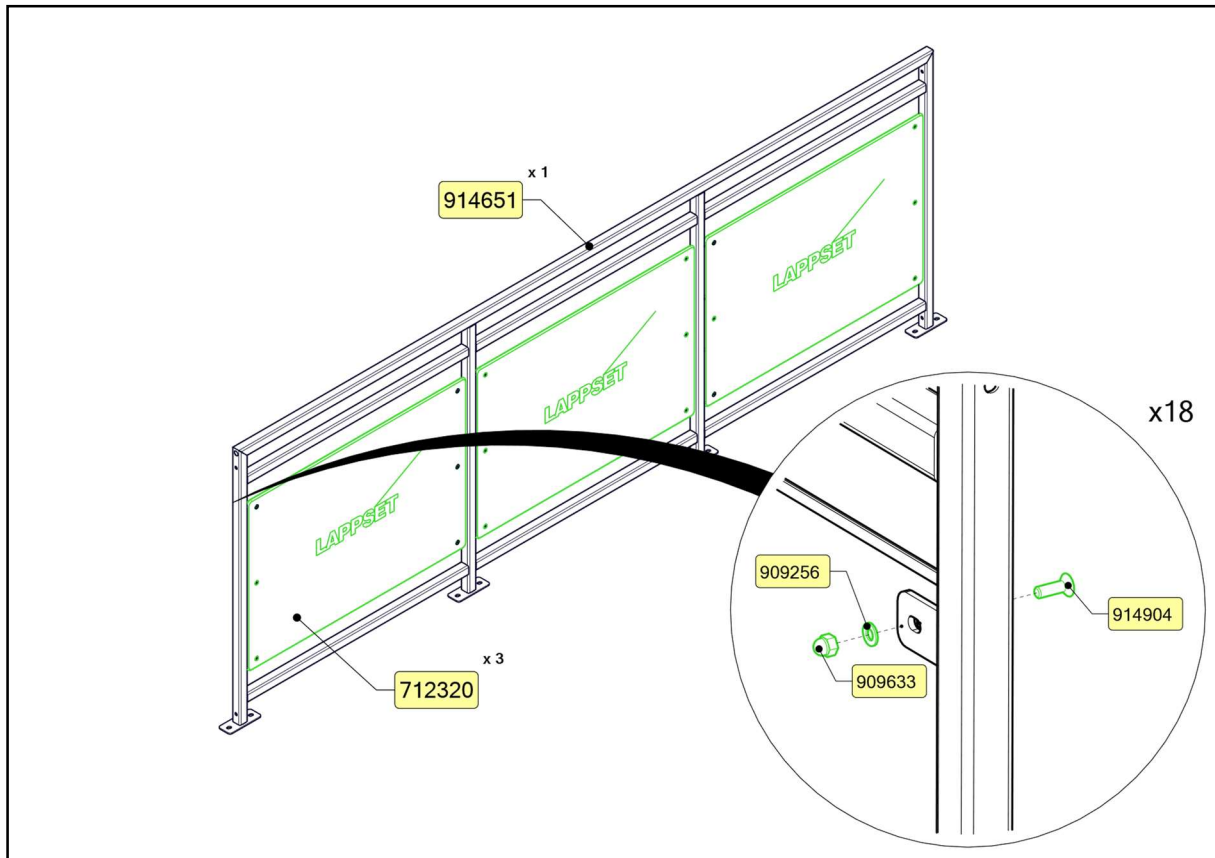

## SISU FITNESS STAIRS

### HANDRAIL -2 (1 PC)

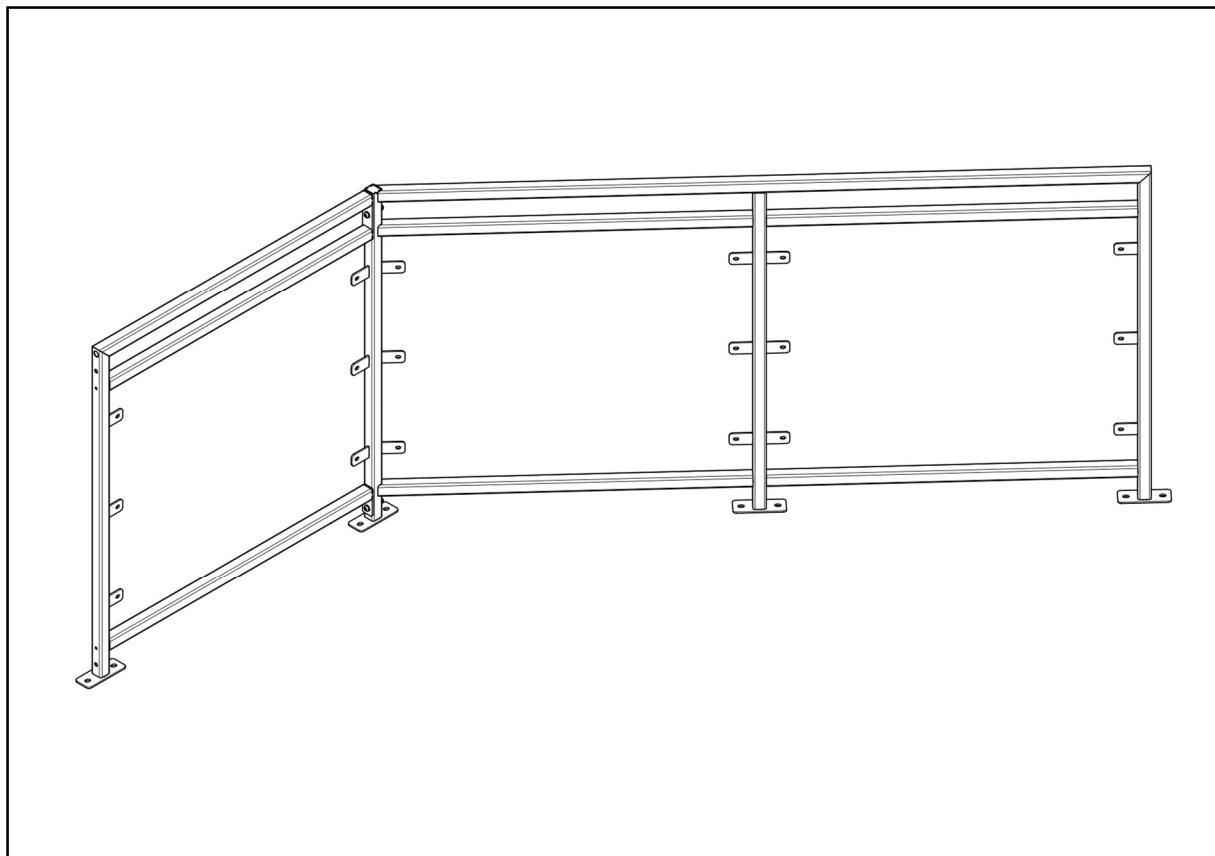
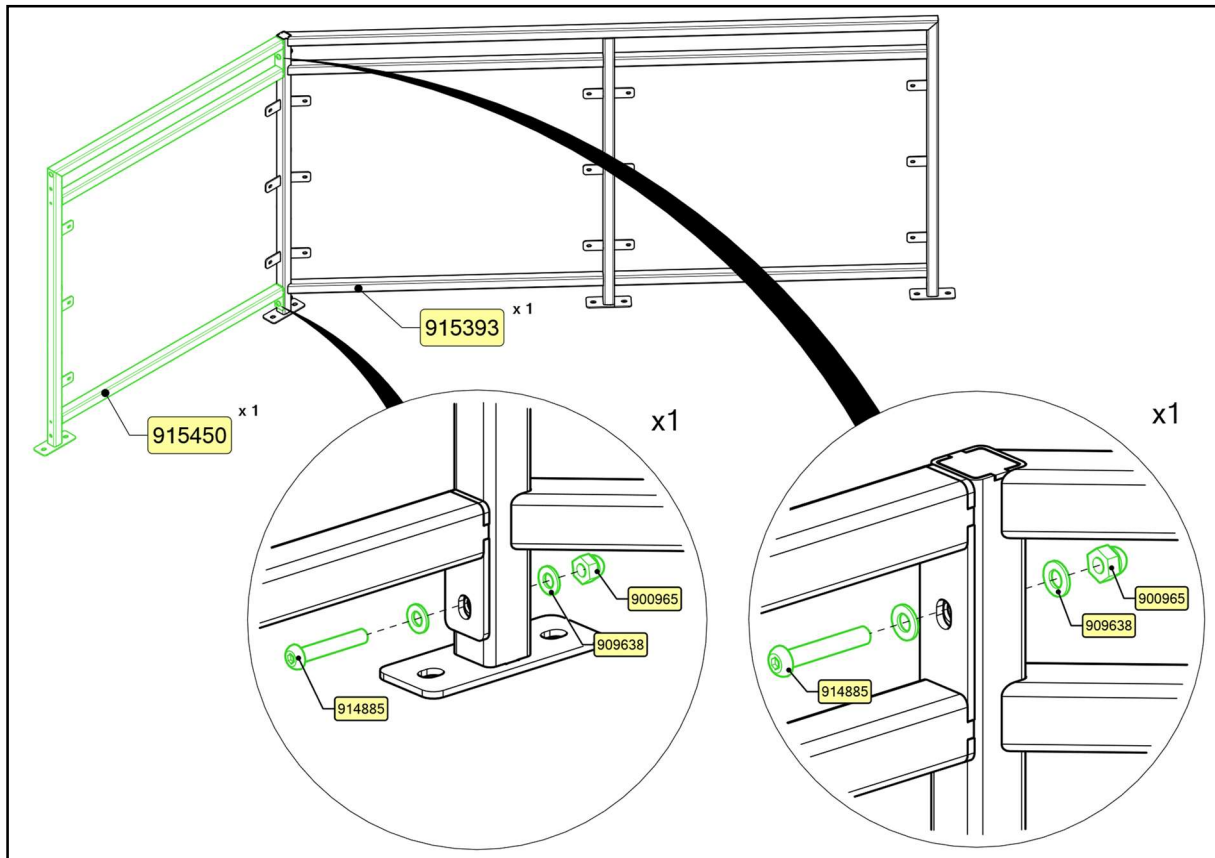

## SISU FITNESS STAIRS

### HANDRAIL -2 (1 PC)

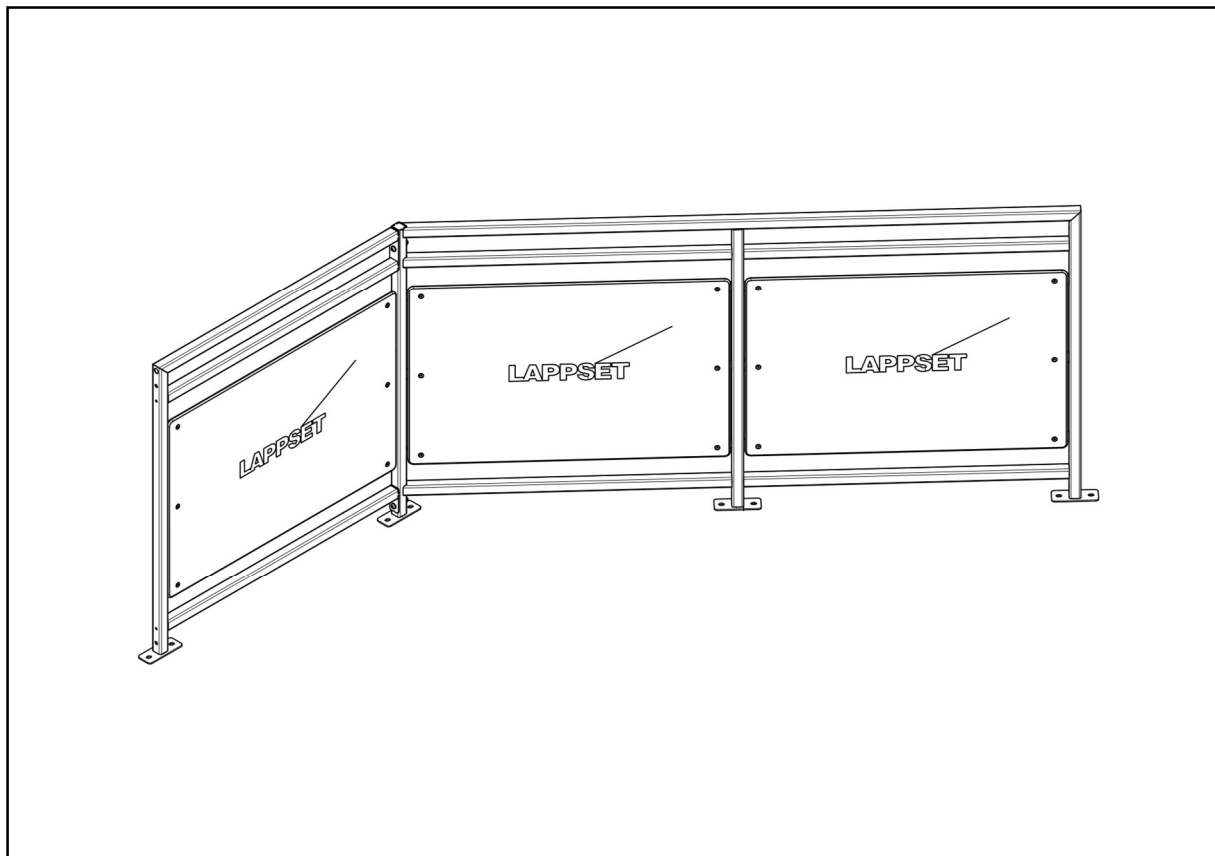
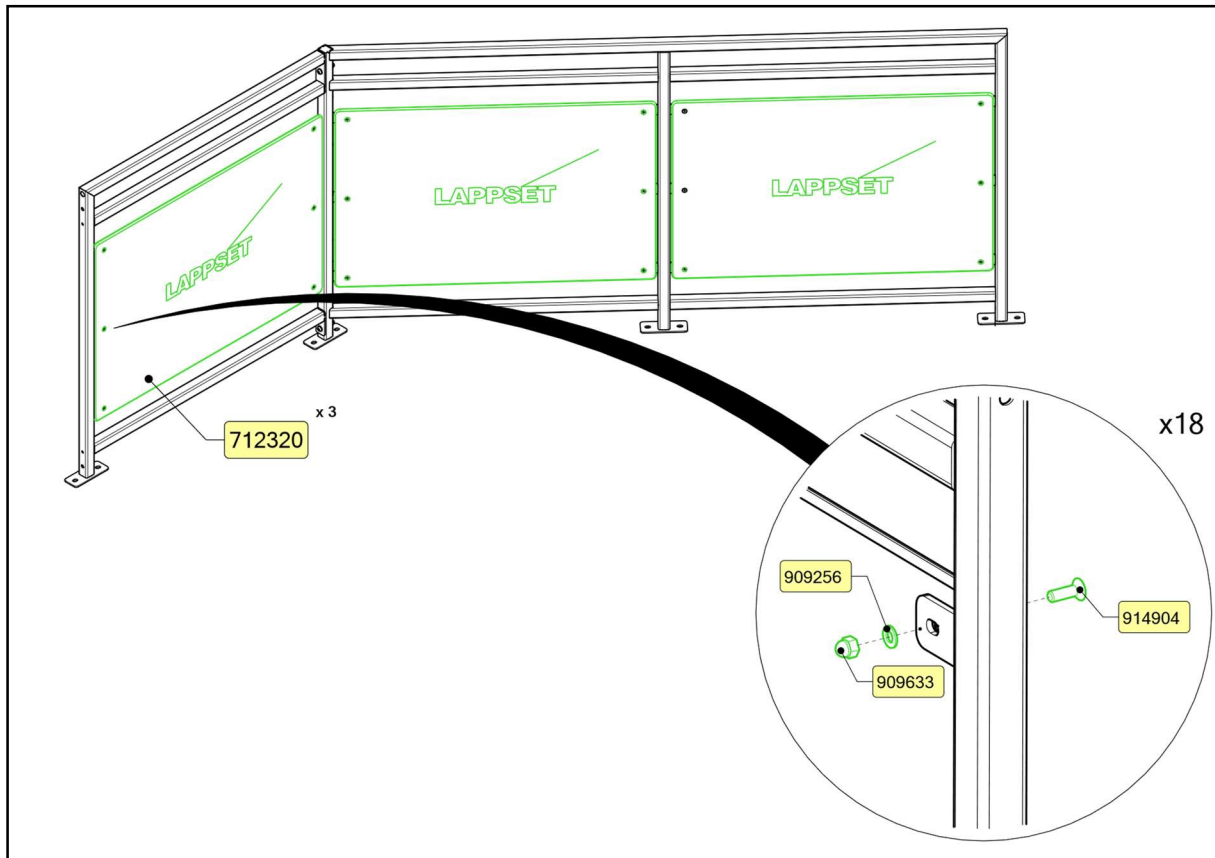

## SISU FITNESS STAIRS

### ASSEMBLY

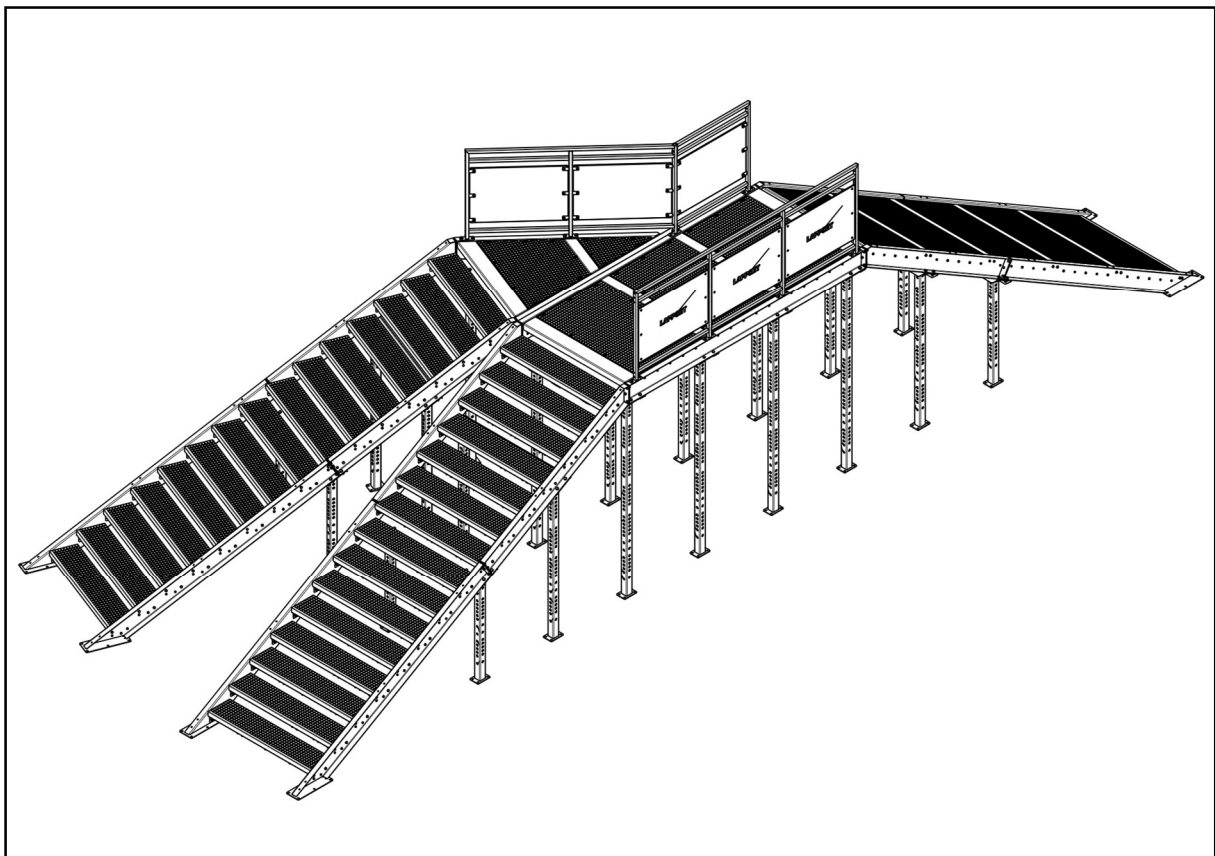
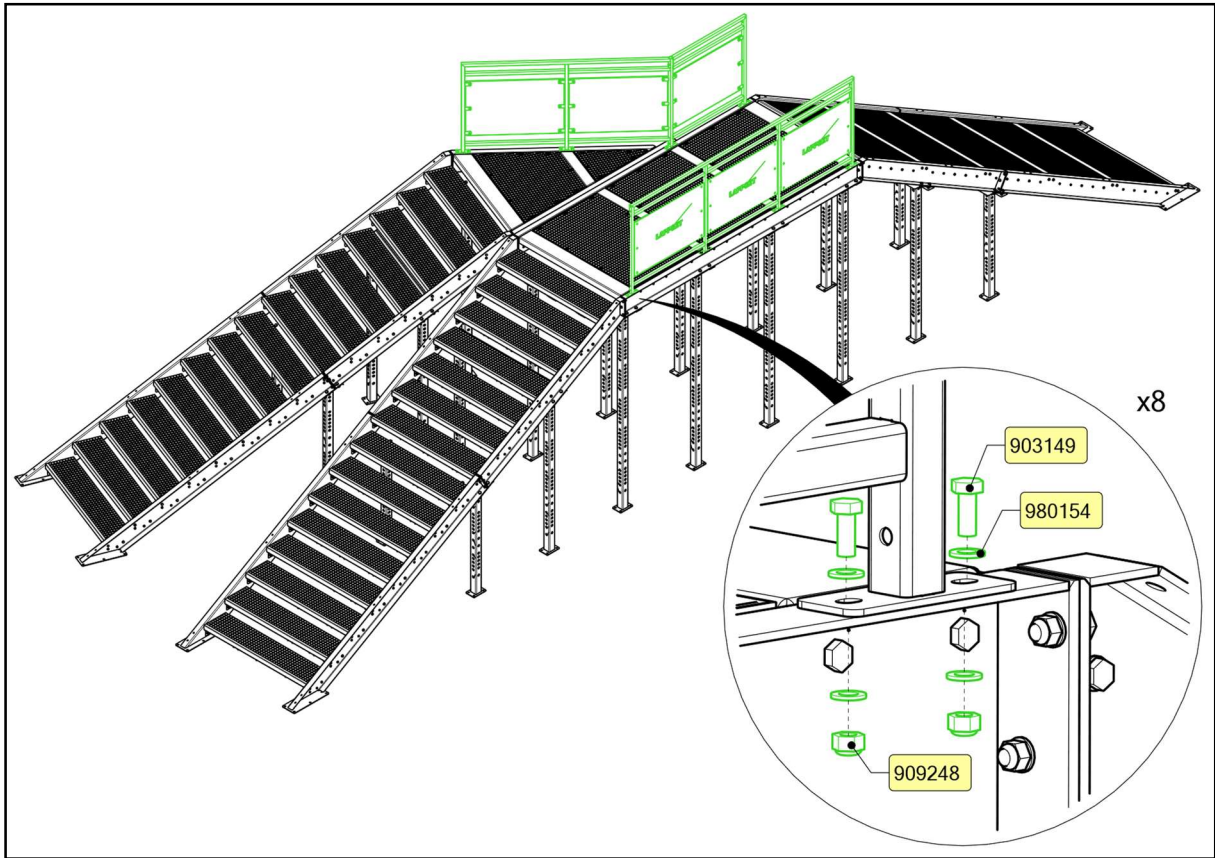

## SISU FITNESS STAIRS

### ASSEMBLY

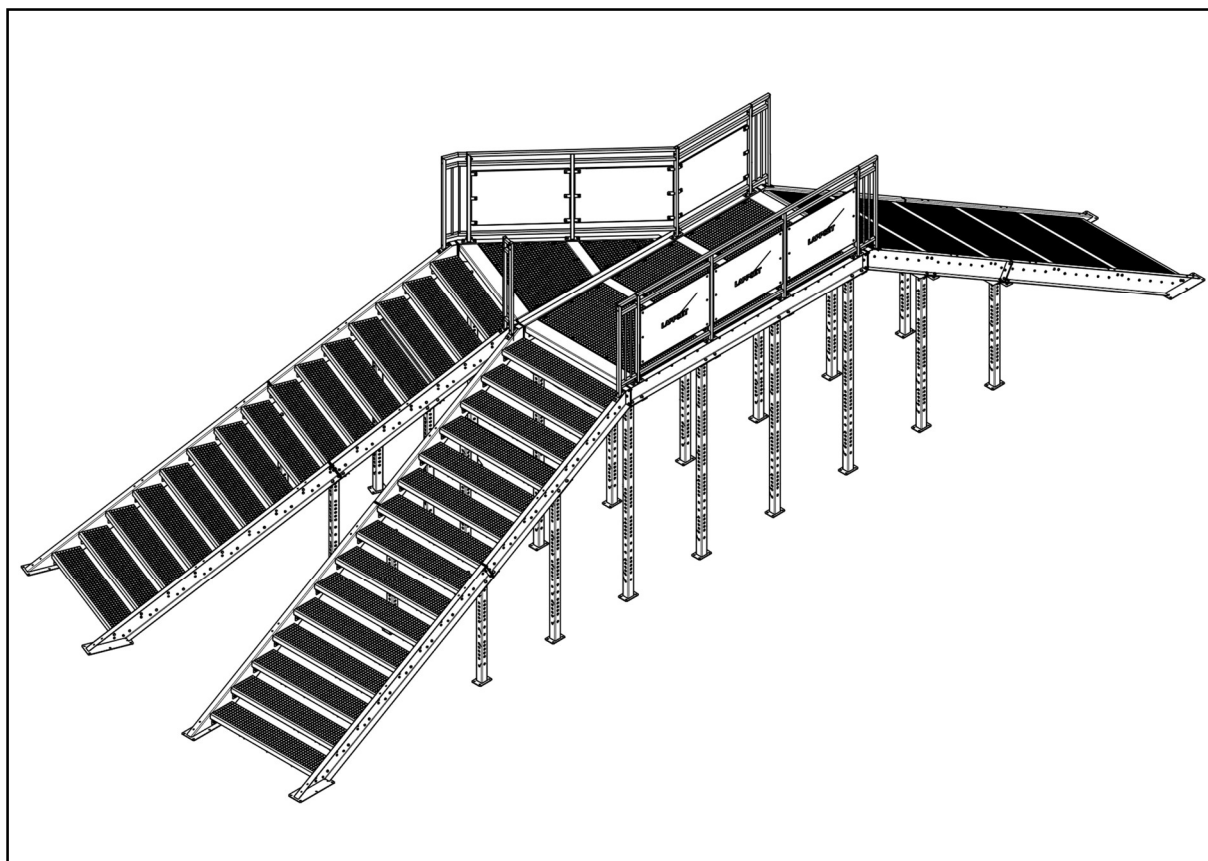
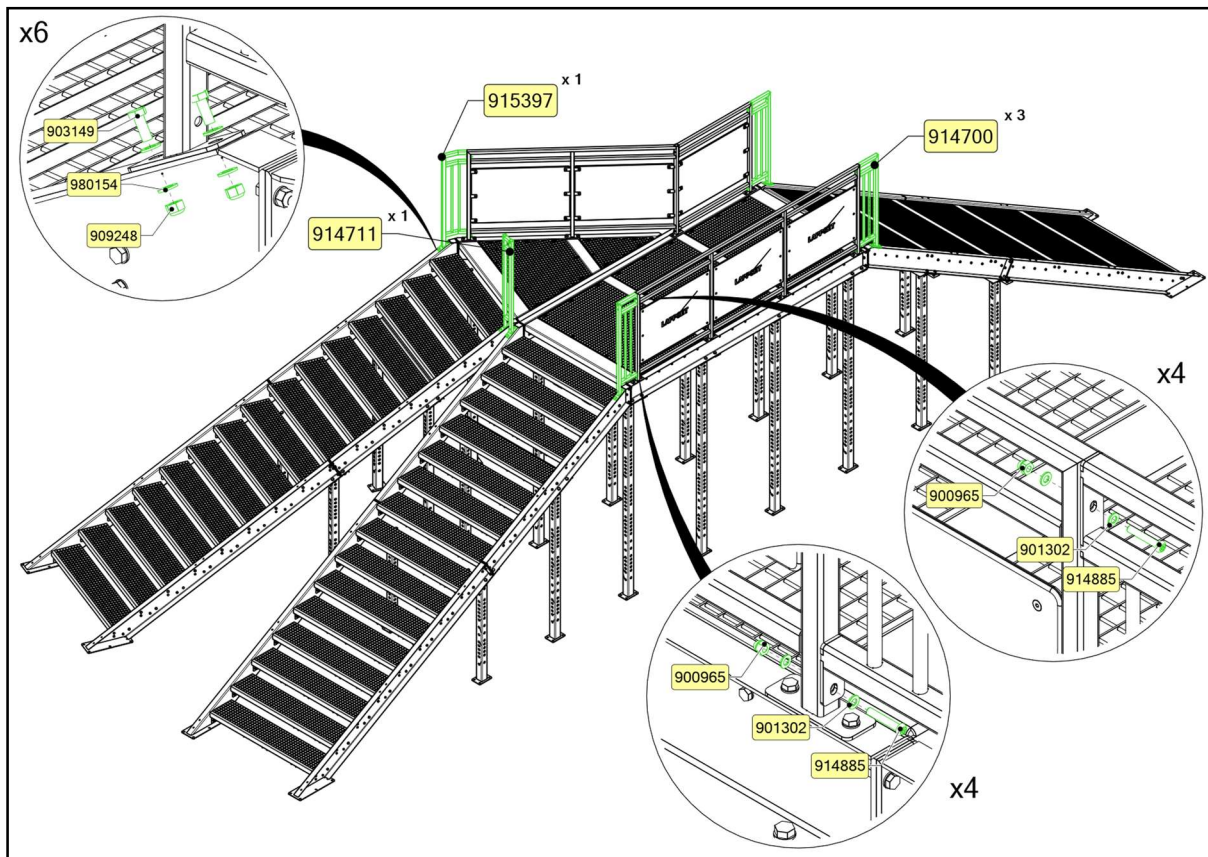

## SISU FITNESS STAIRS

### ASSEMBLY

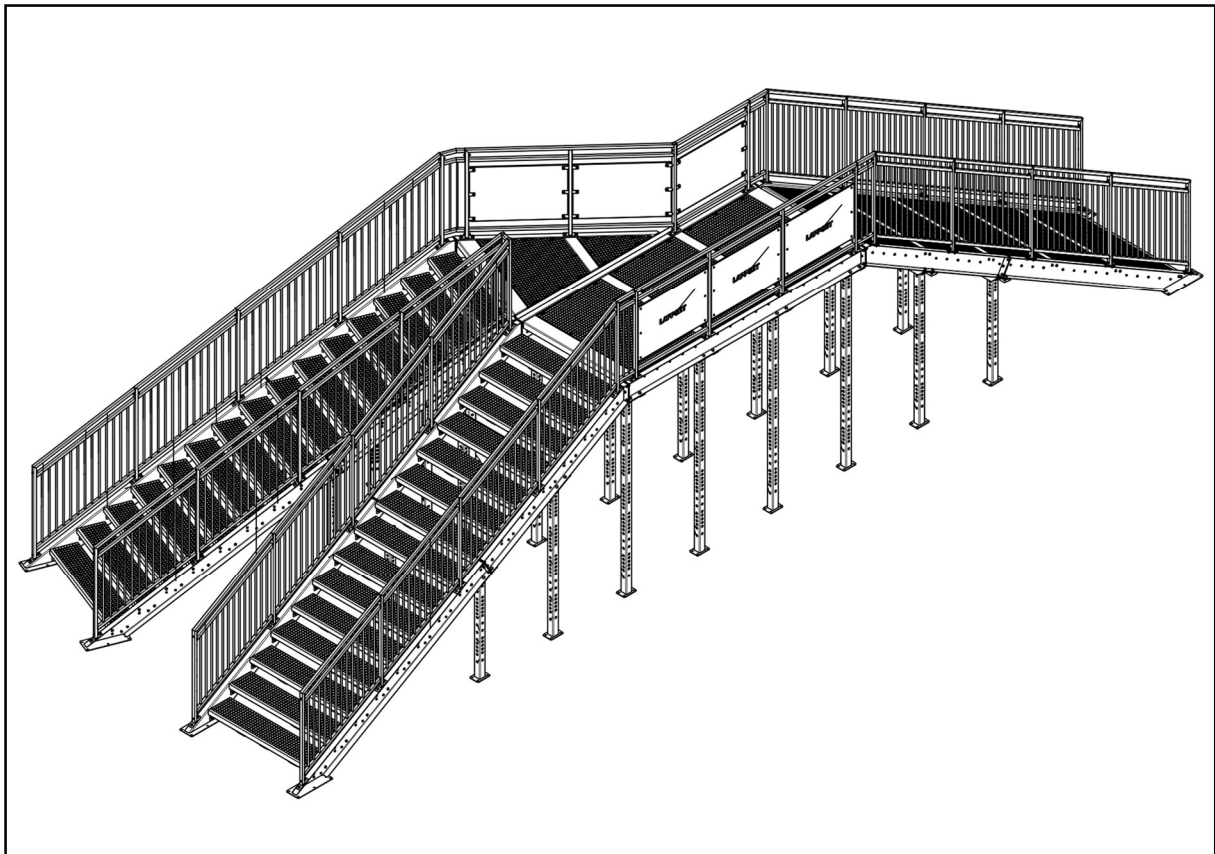
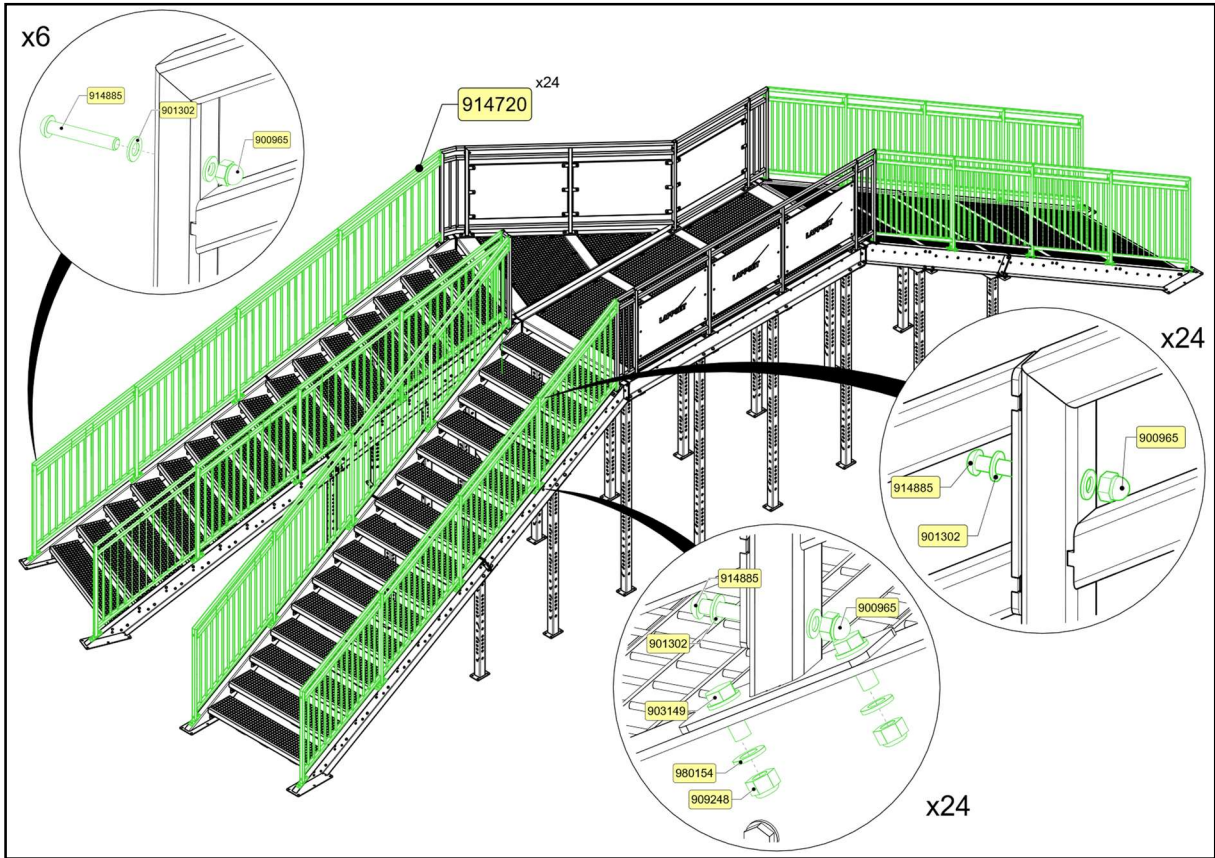

## SISU FITNESS STAIRS

### ADDITIONAL STEPS (7 PCS)

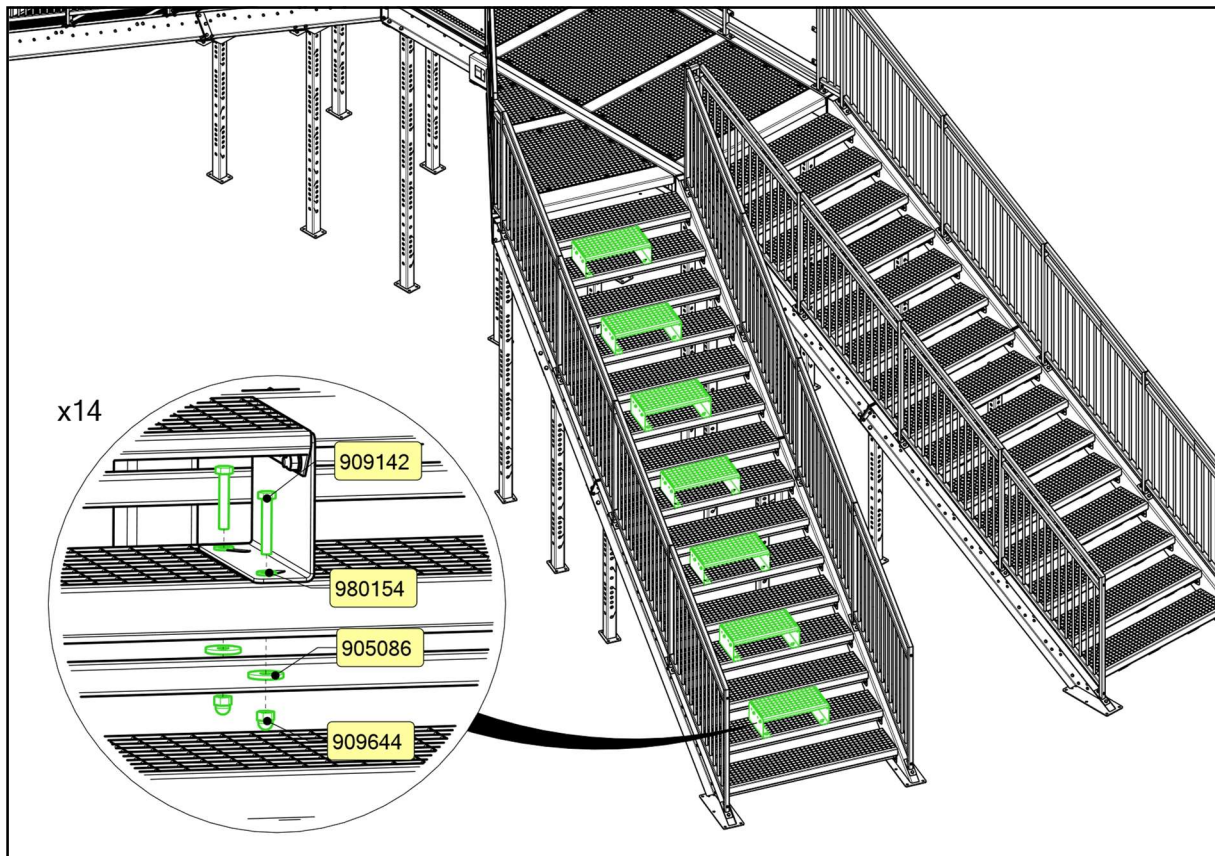
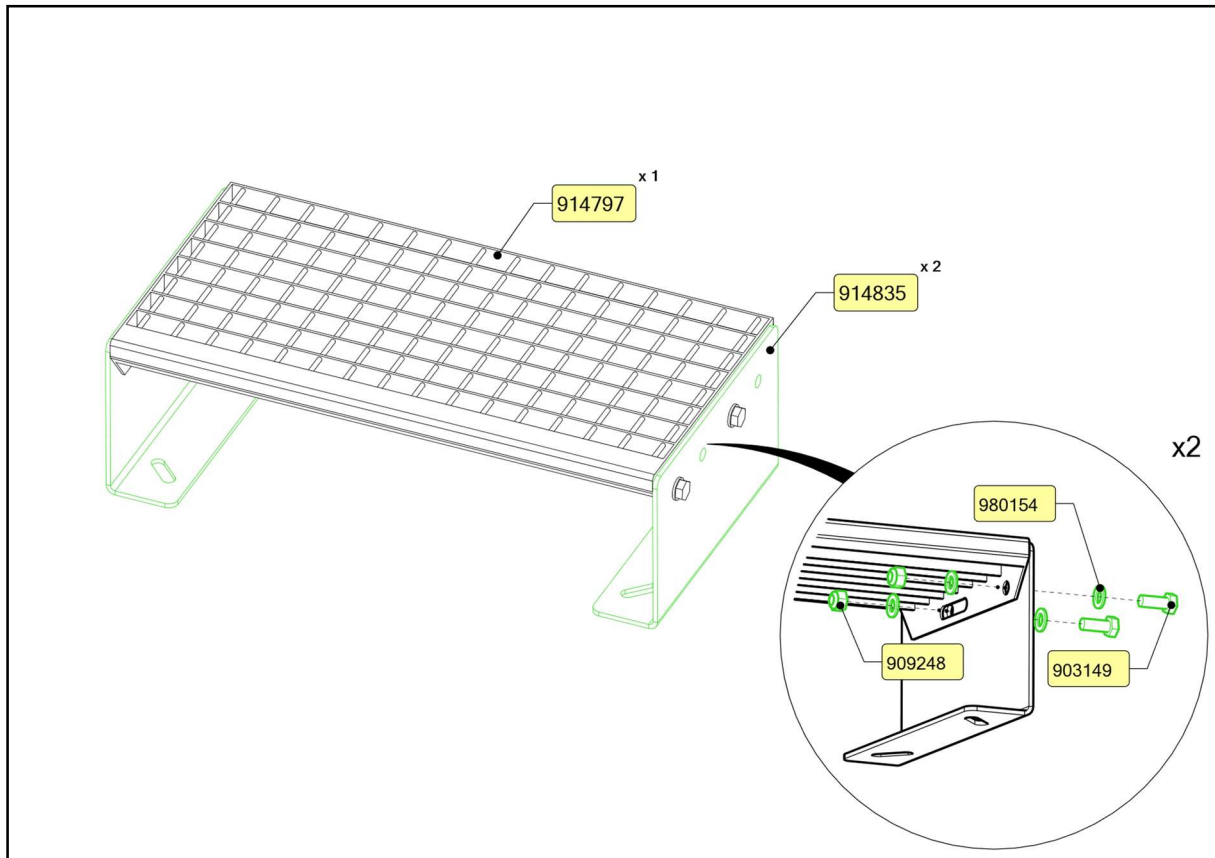

**SISU FITNESS STAIRS**

**ADDITIONAL STEPS (7 PCS)**

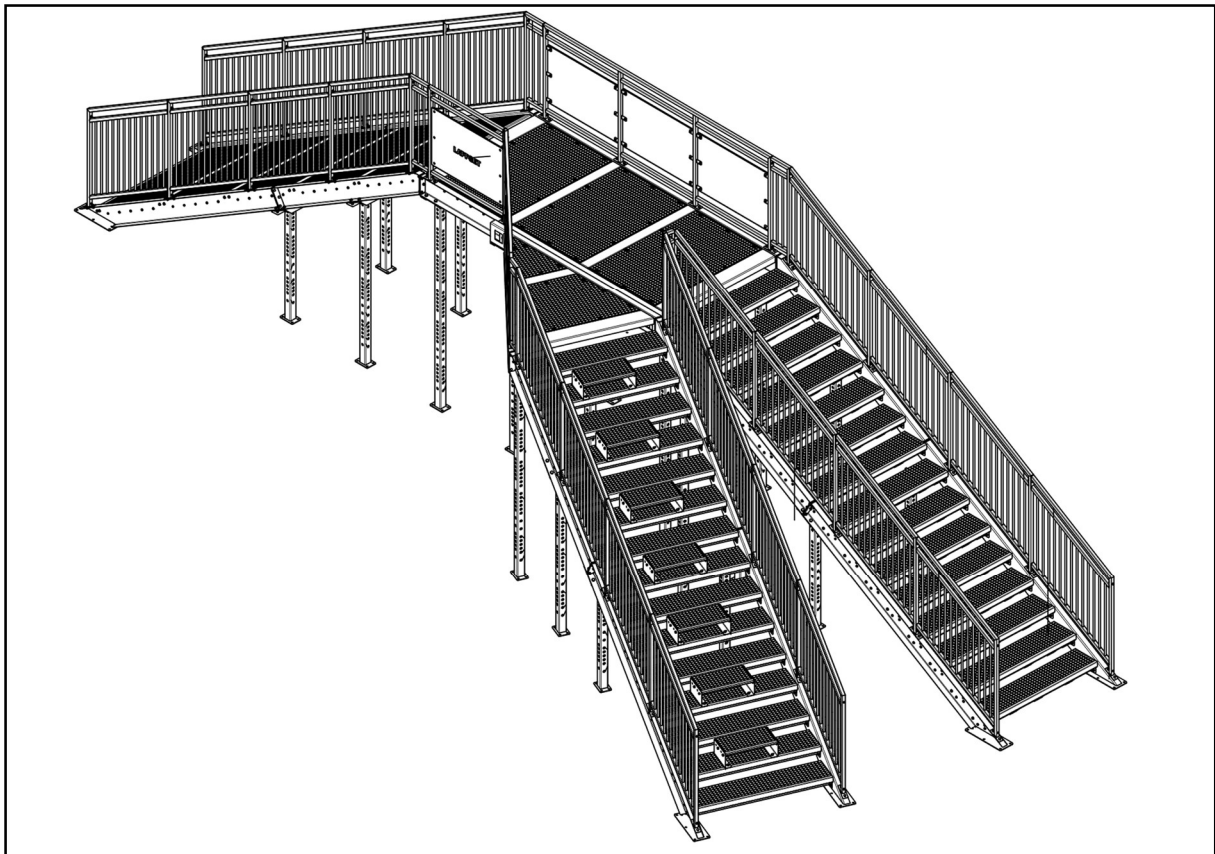
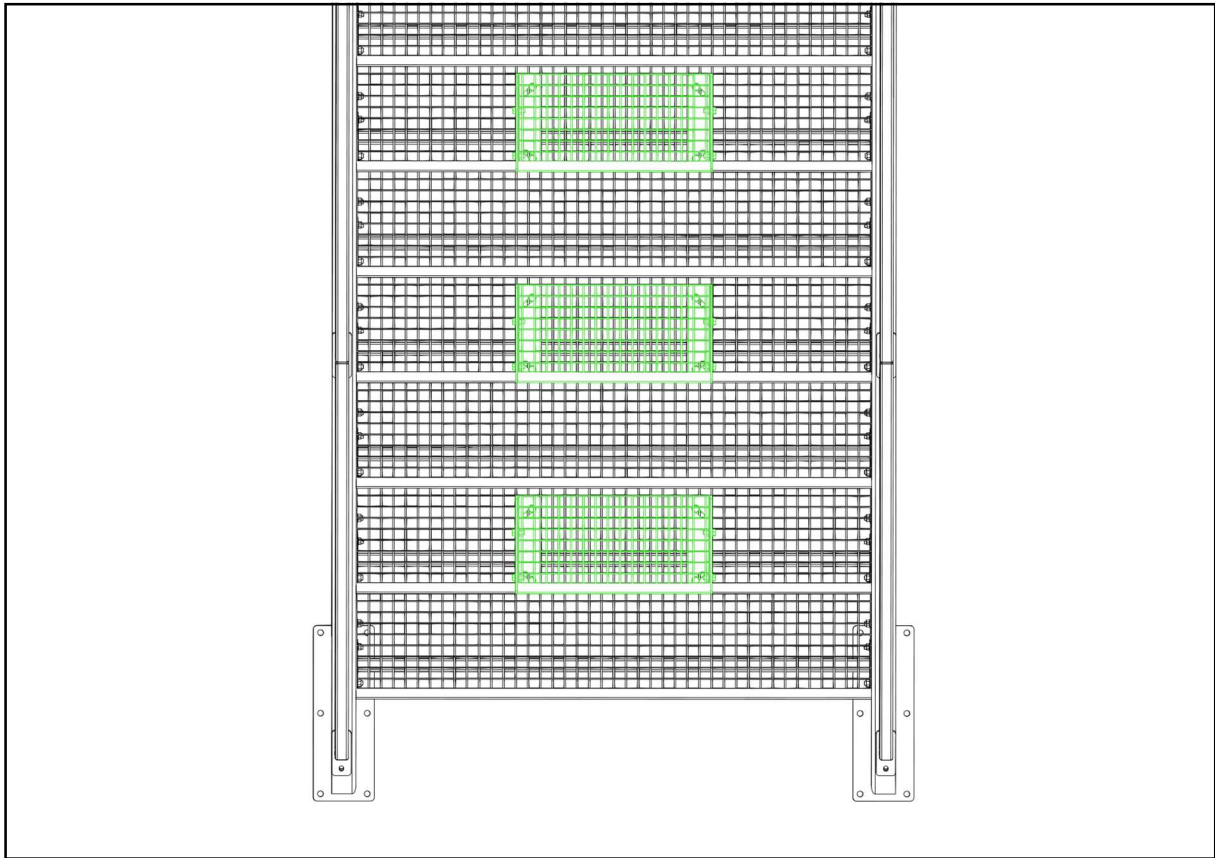

## SISU FITNESS STAIRS

### BALL TARGET (2 PCS)

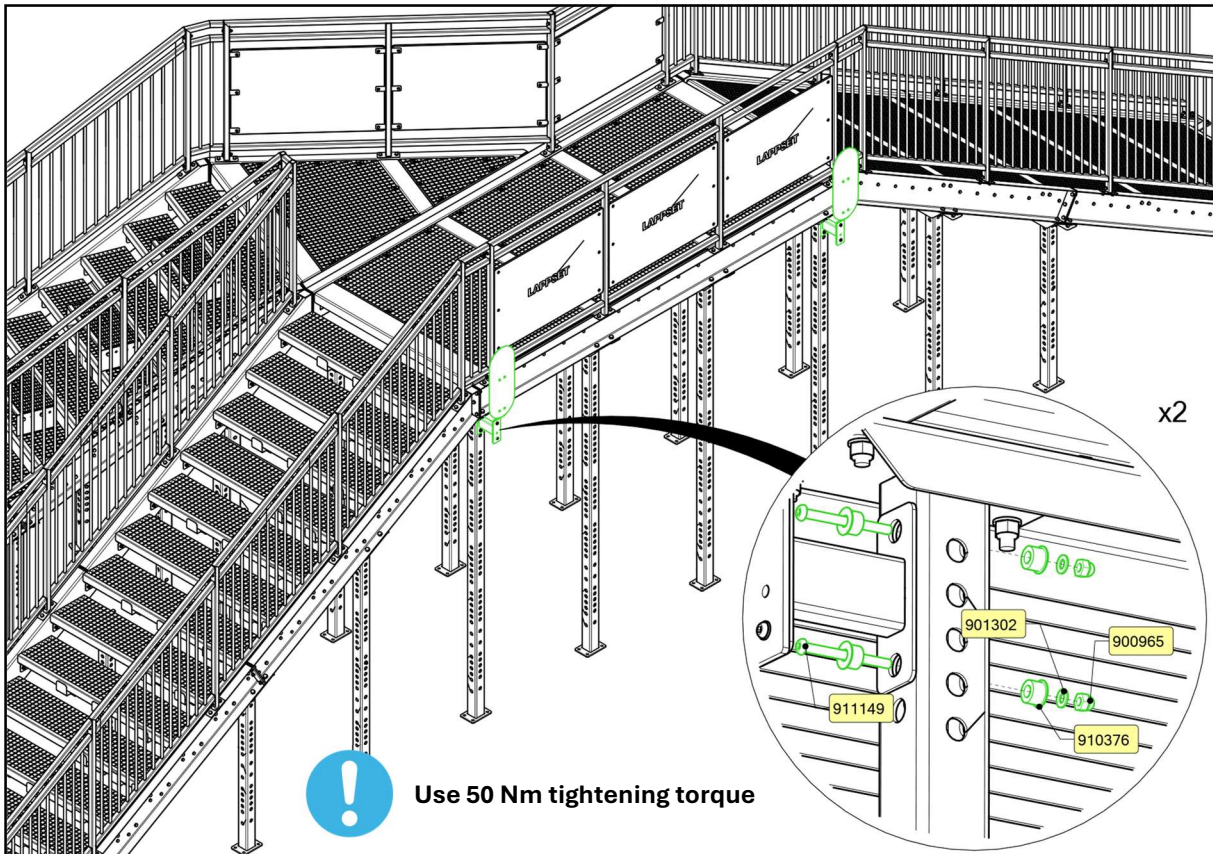
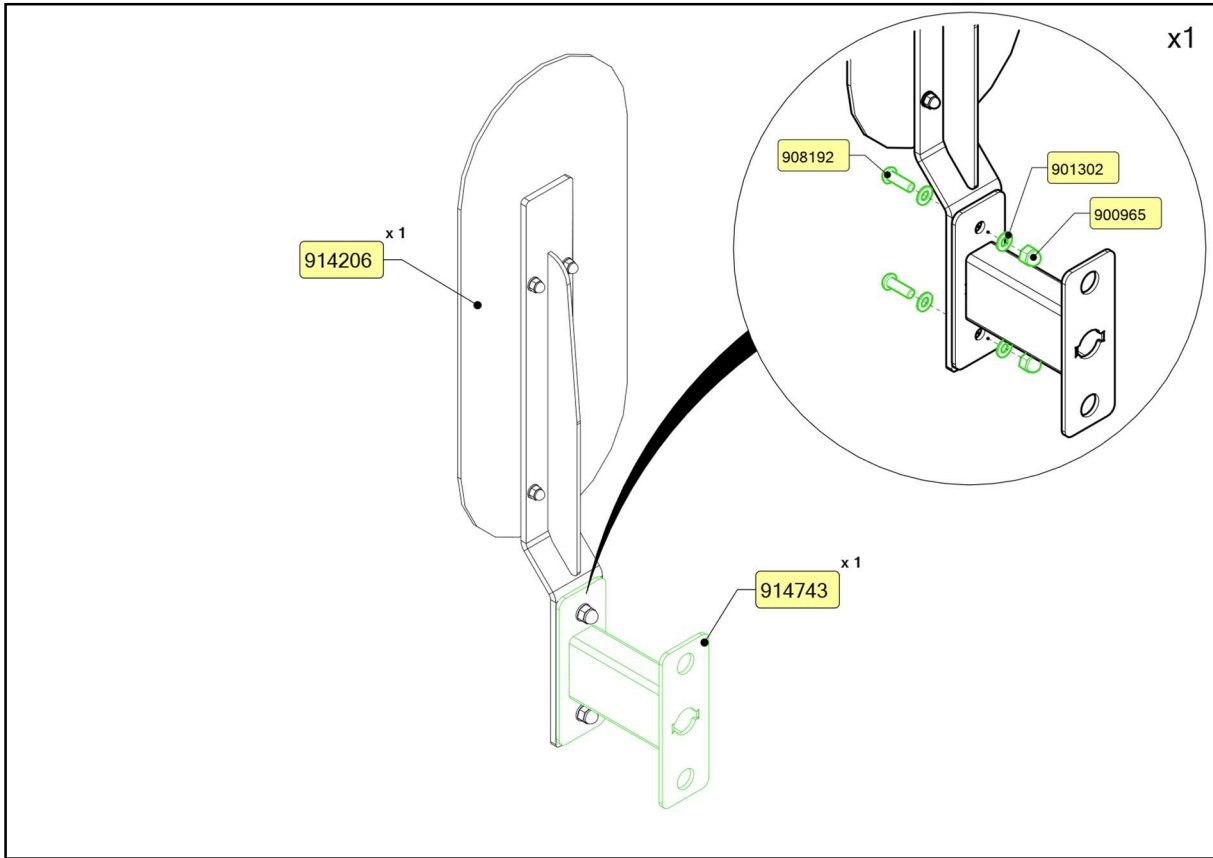

## SISU FITNESS STAIRS

### GYMNASTICS WALL

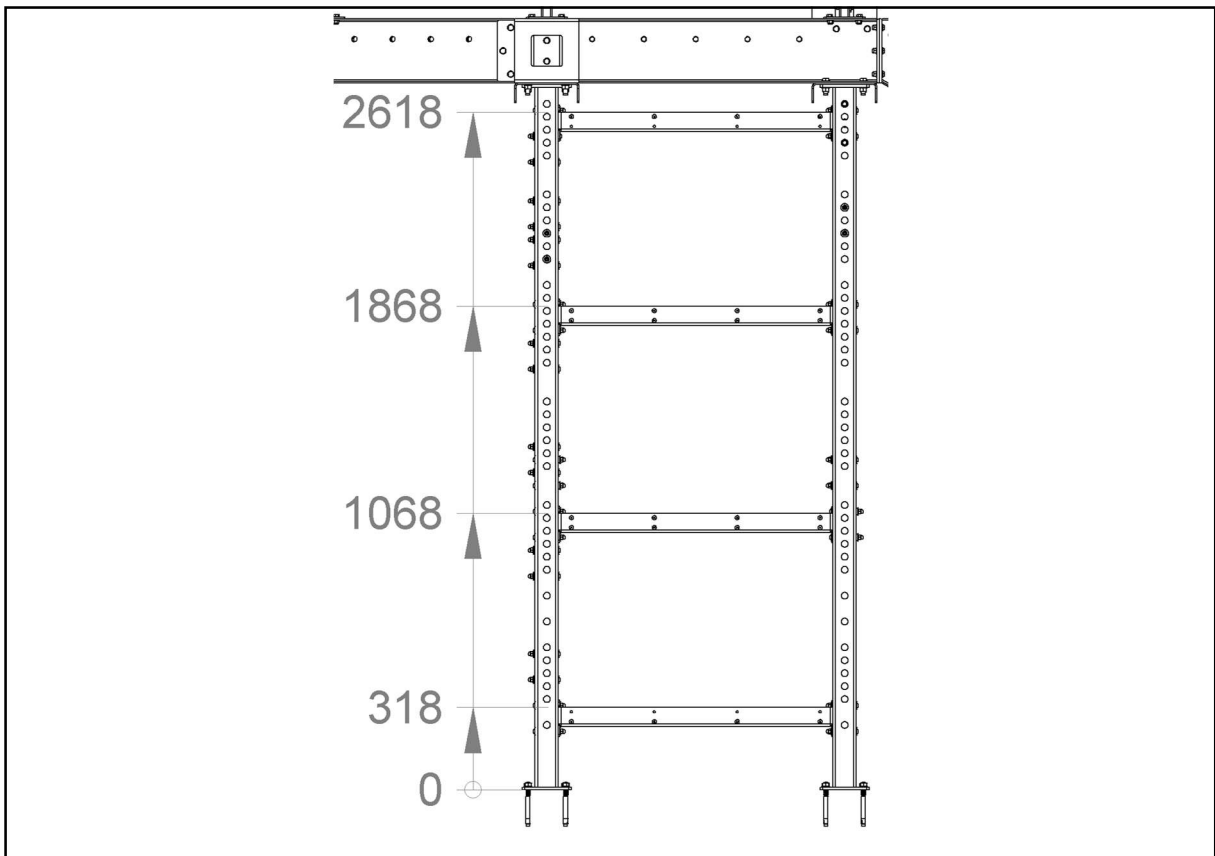
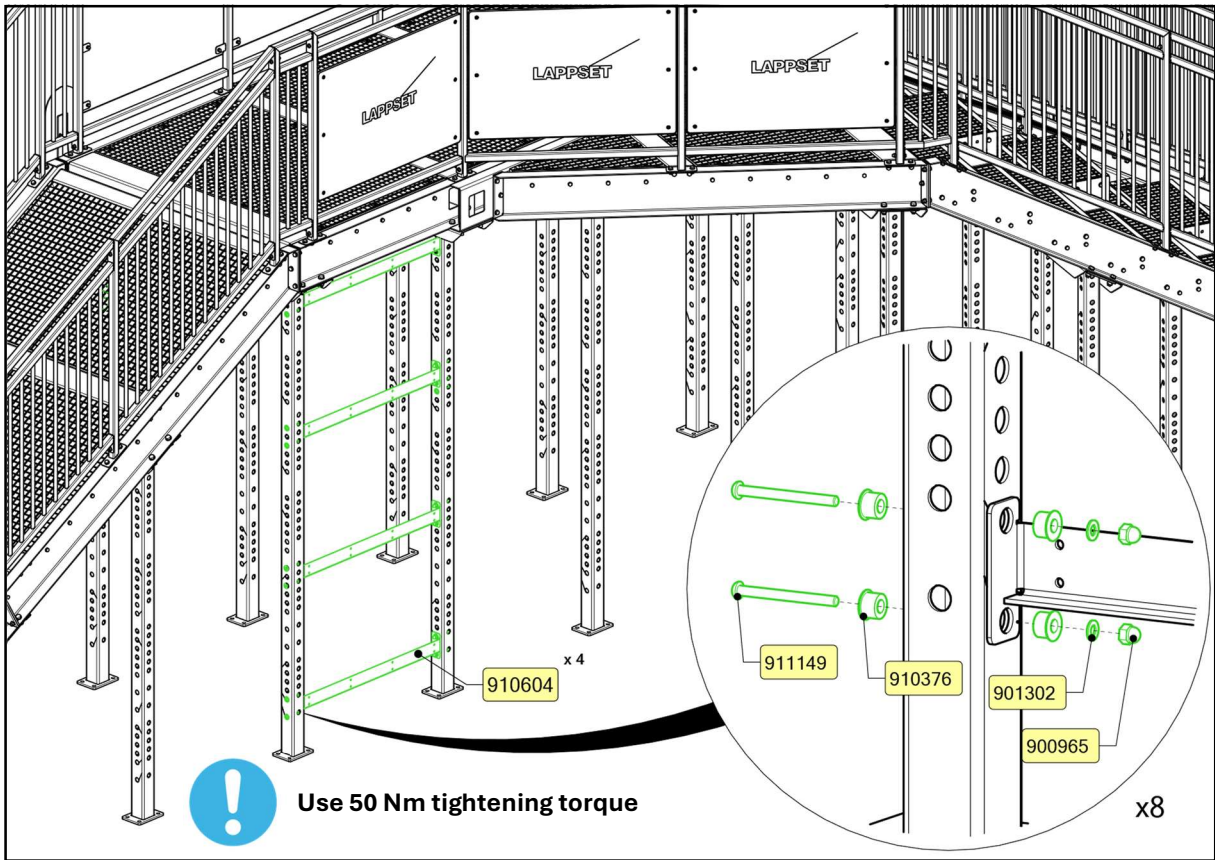

## SISU FITNESS STAIRS

### GYMNASTICS WALL

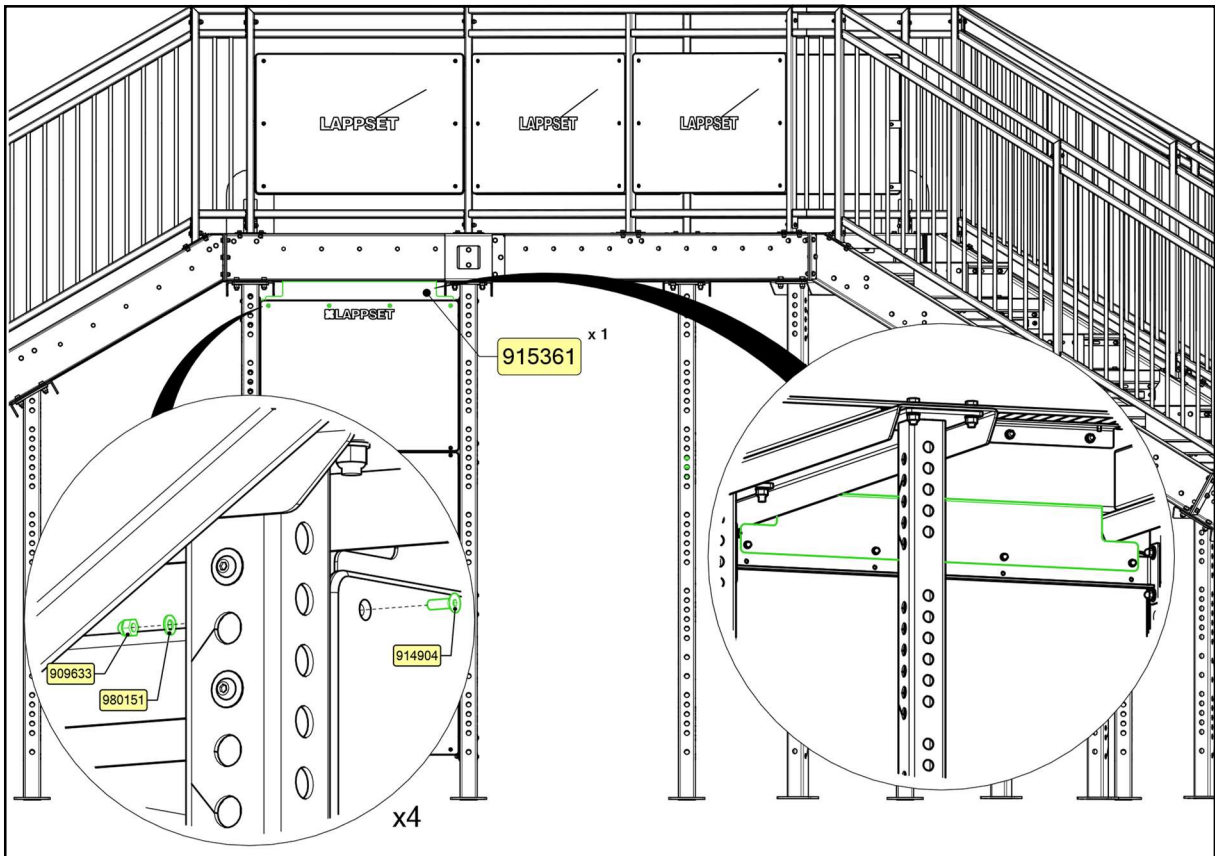
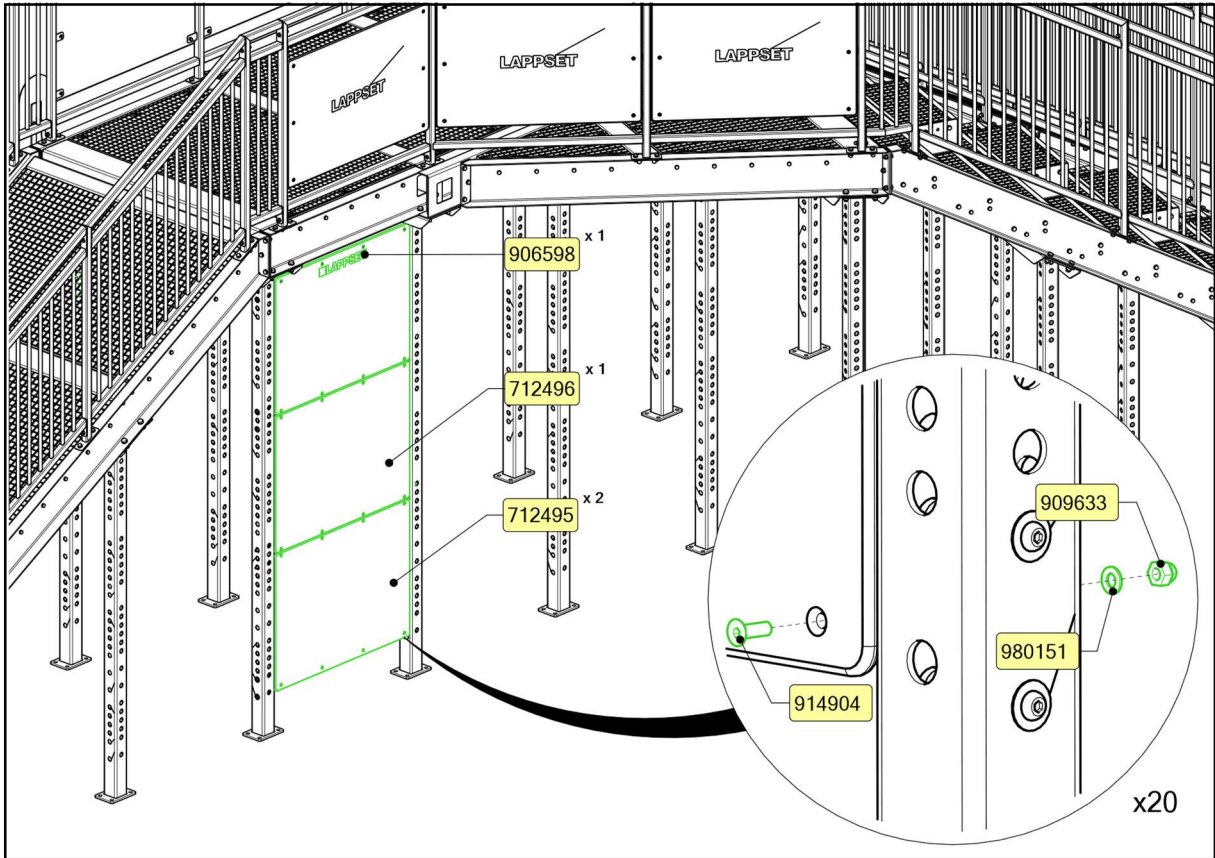

## SISU FITNESS STAIRS

### BARS-1 (4 PCS)

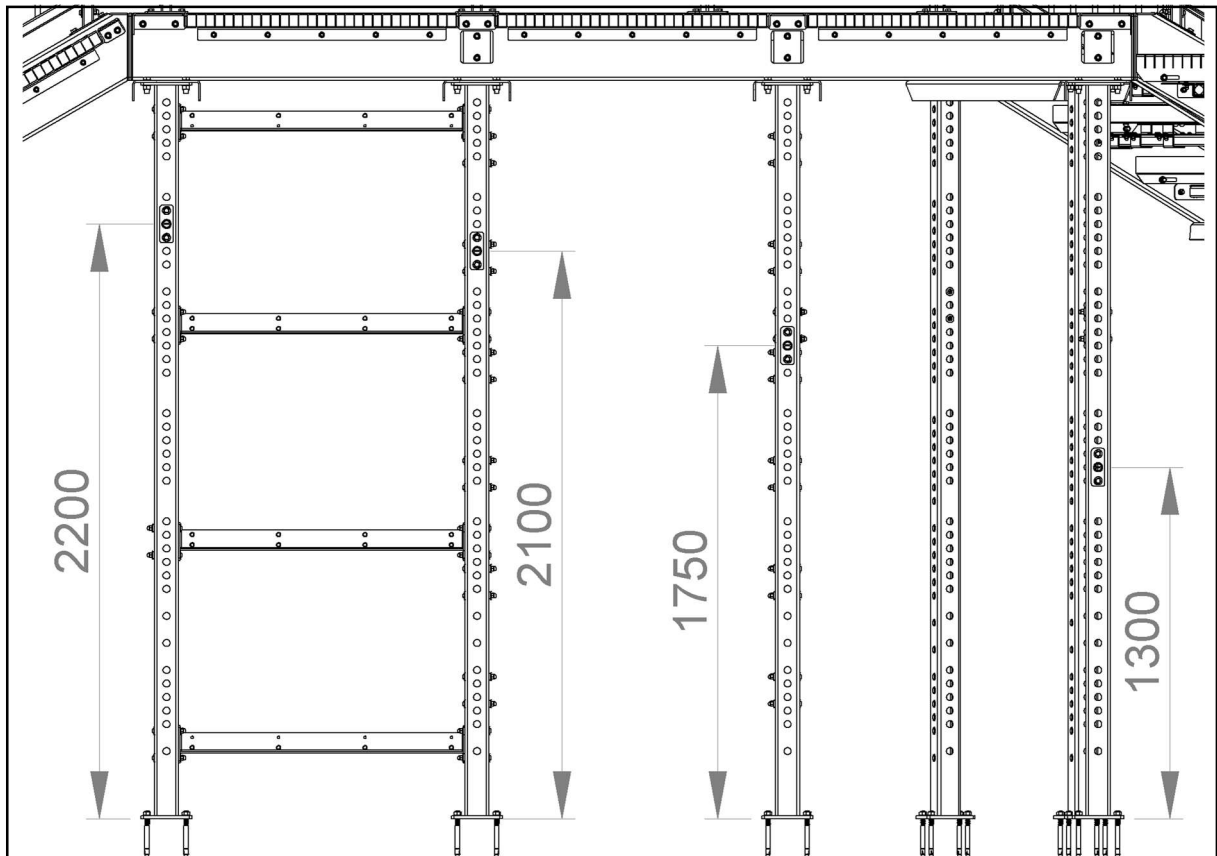
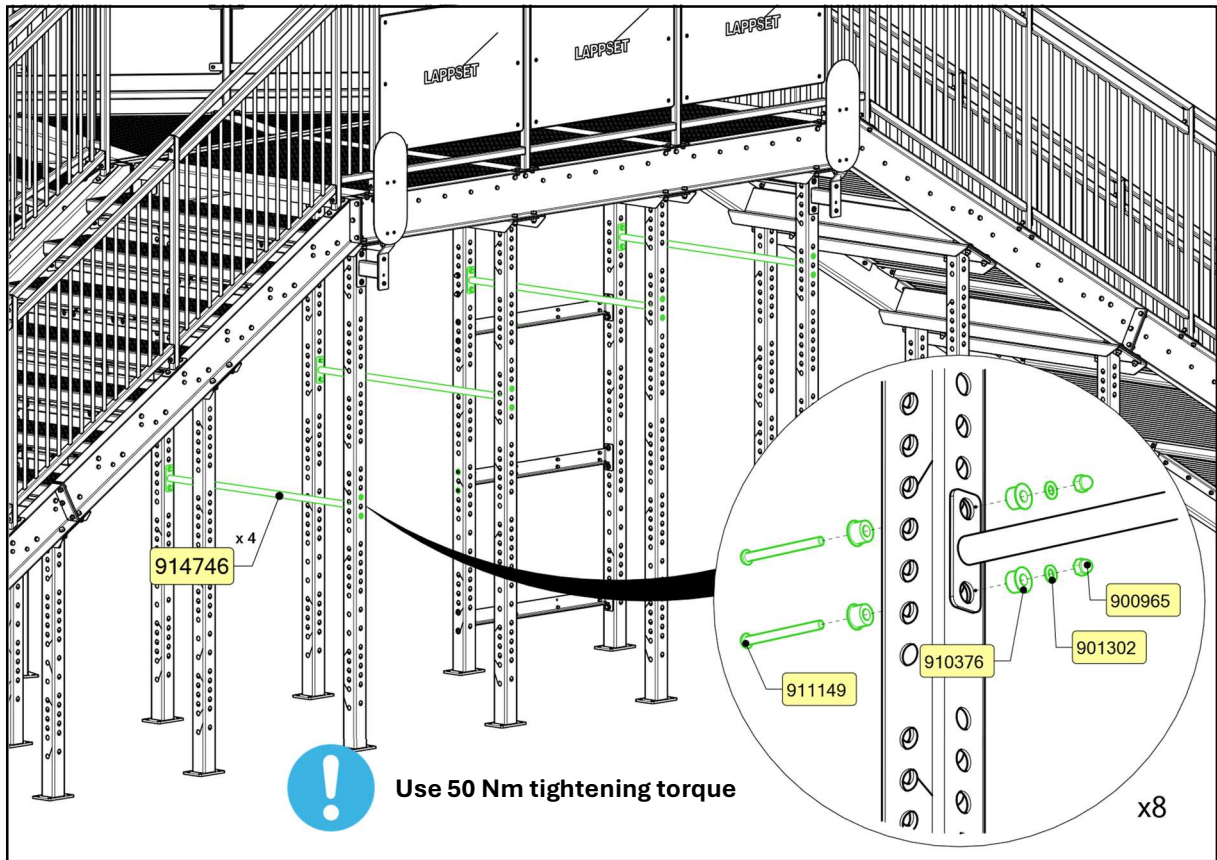

## SISU FITNESS STAIRS

### BARS-2 (8 PCS)

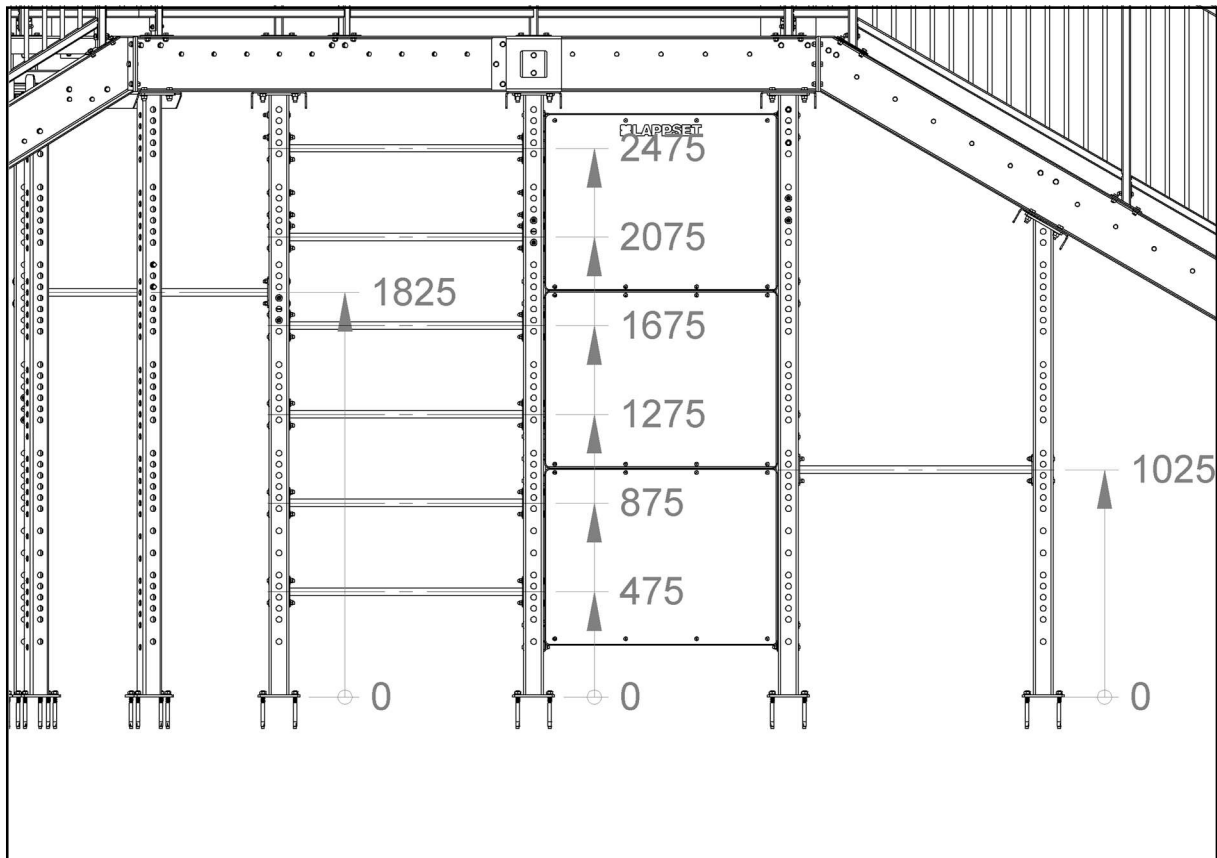
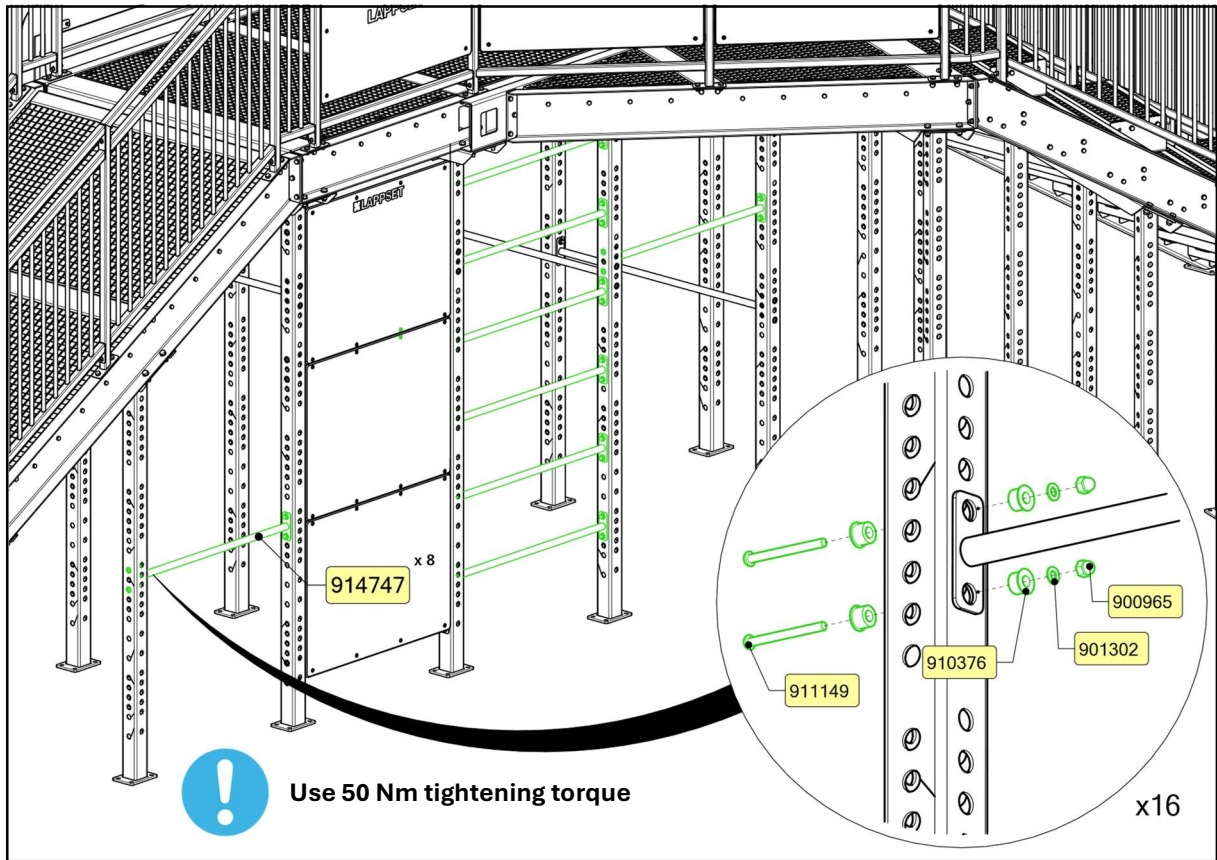

## SISU FITNESS STAIRS

### BARS-3 (3 PCS)

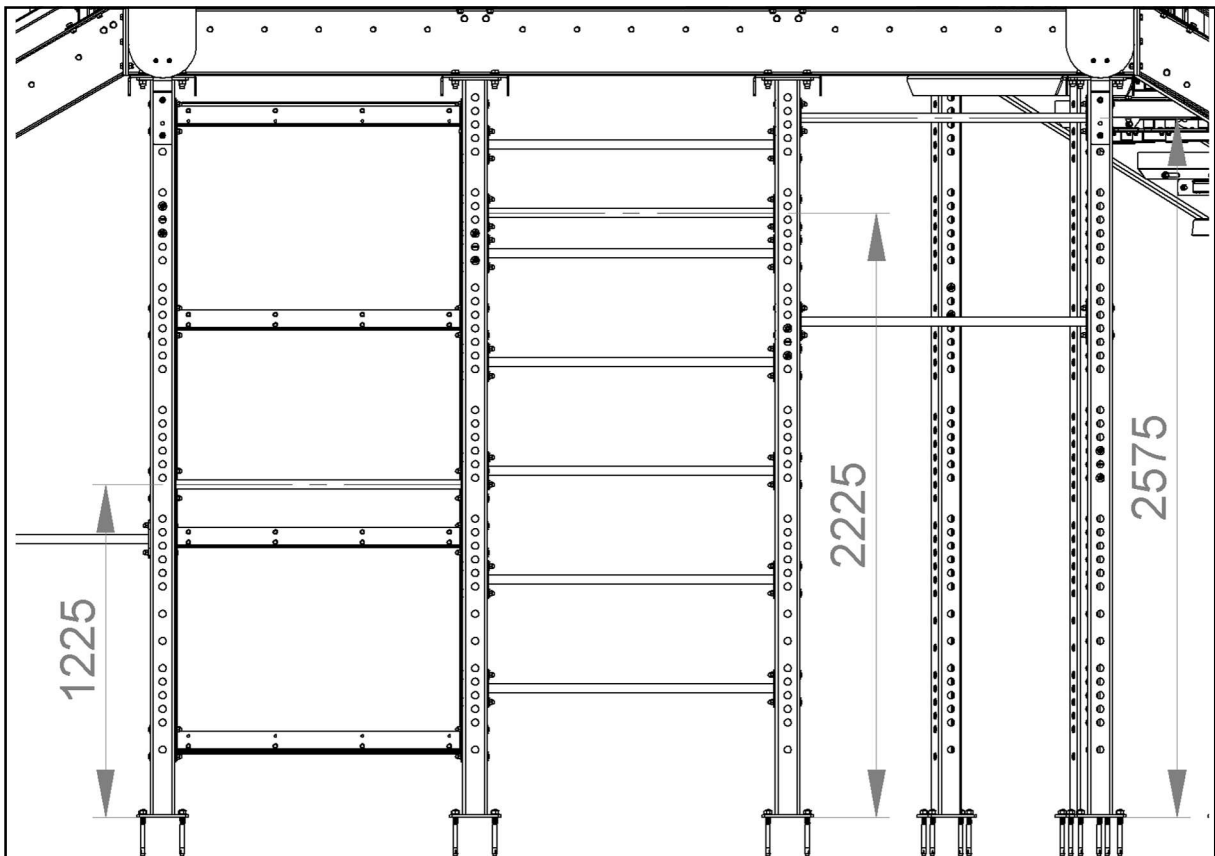
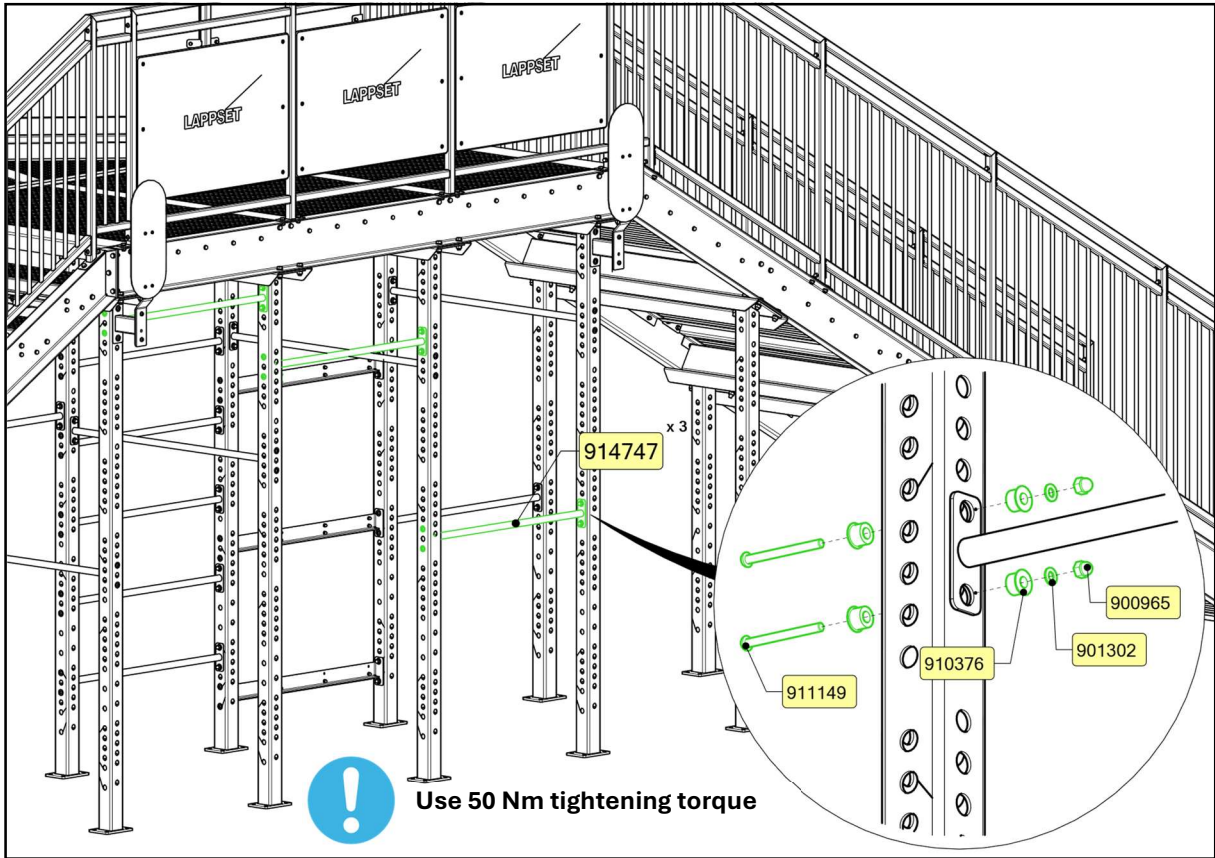

## SISU FITNESS STAIRS

### ROPE RINGS (6 PCS)

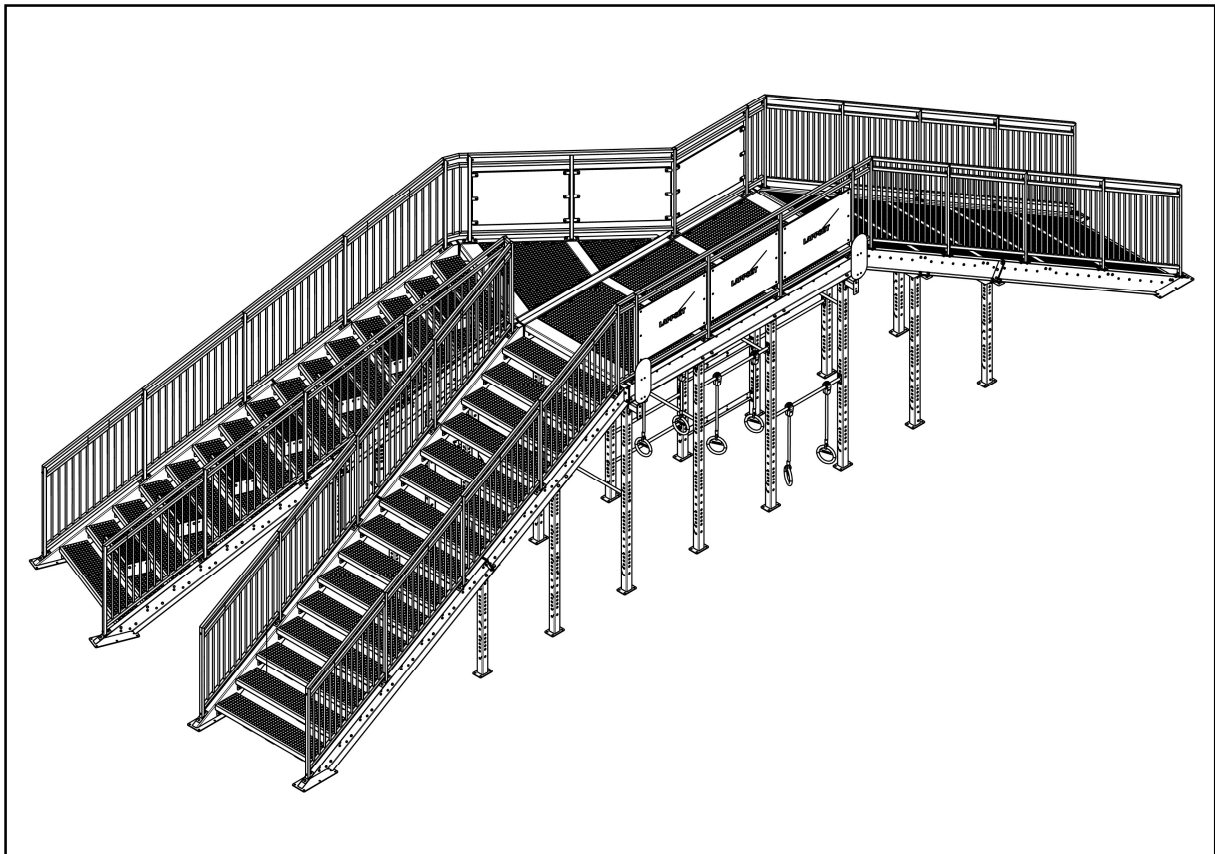
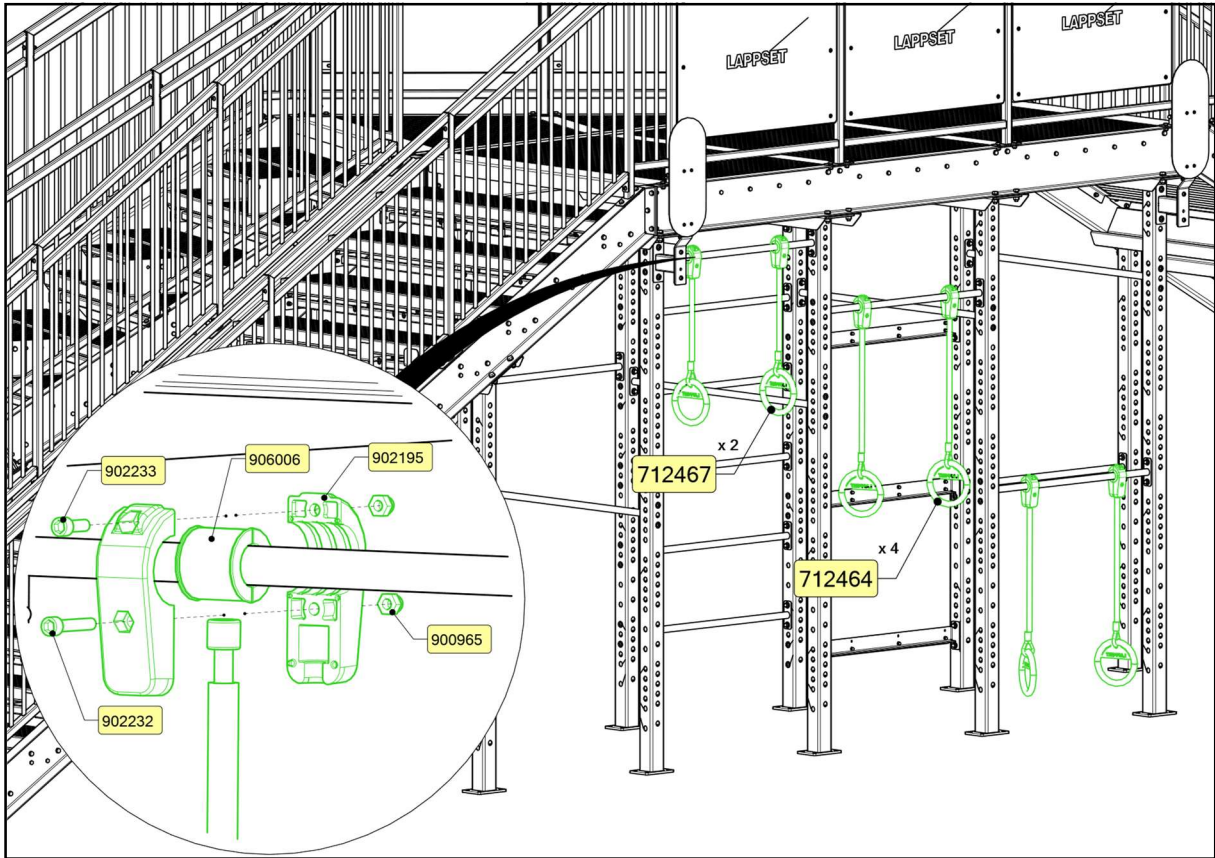

## SISU FITNESS STAIRS

### ANCHORS (124 PCS)

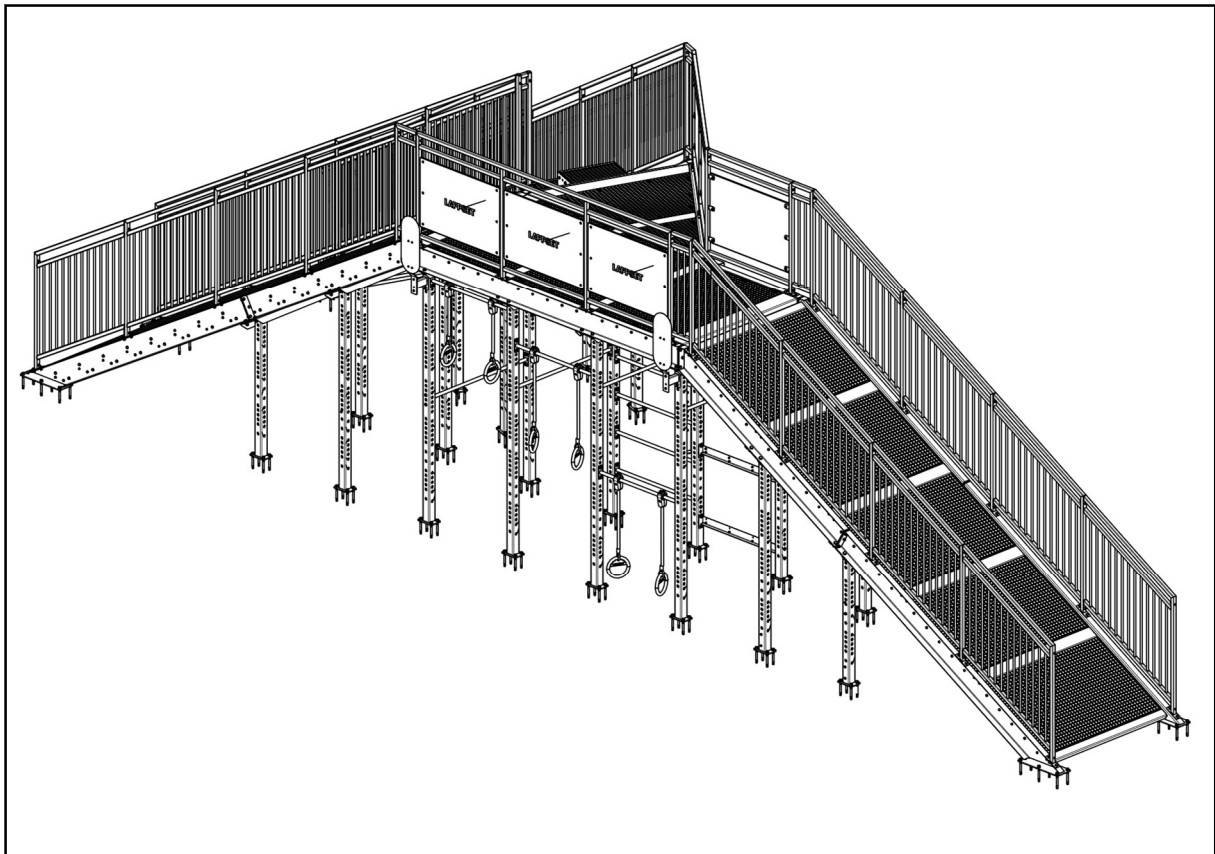
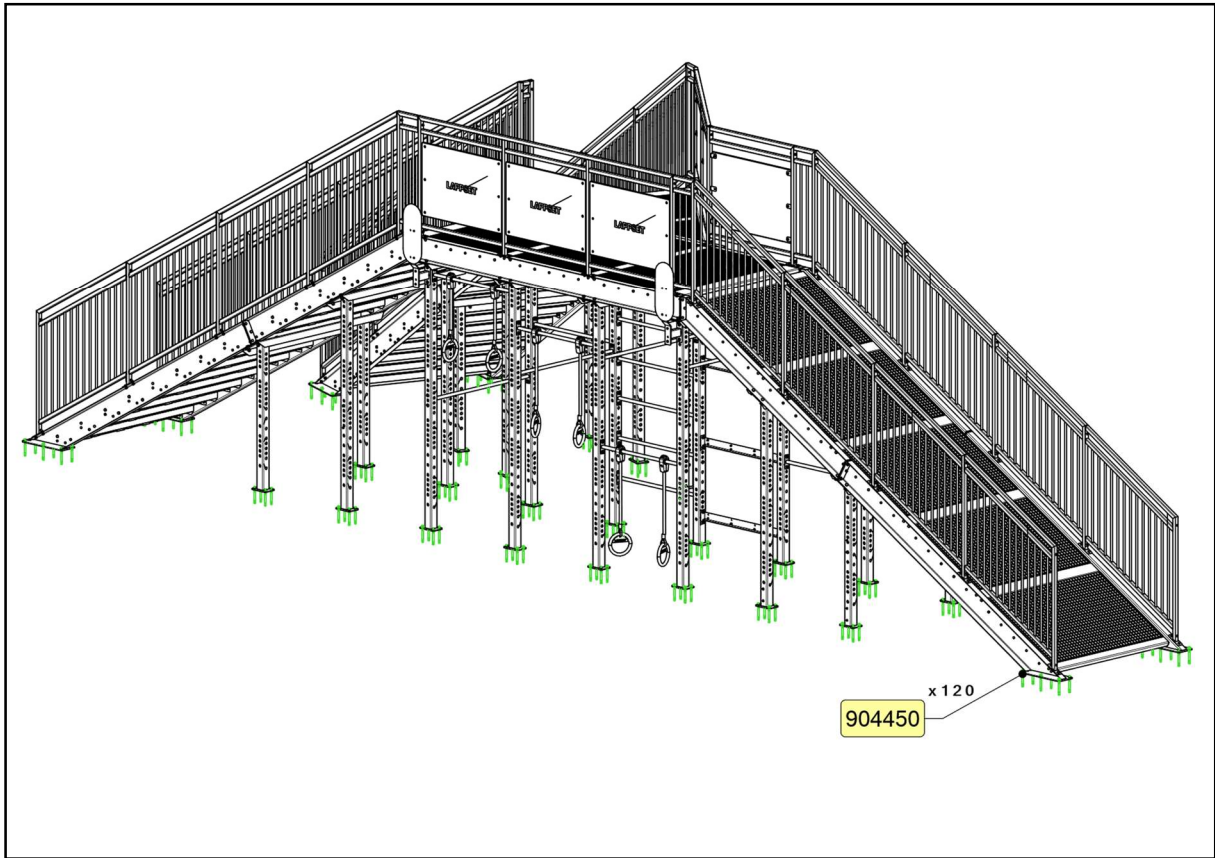

## SISU FITNESS STAIRS

### VERTICAL BAR (1 PC)

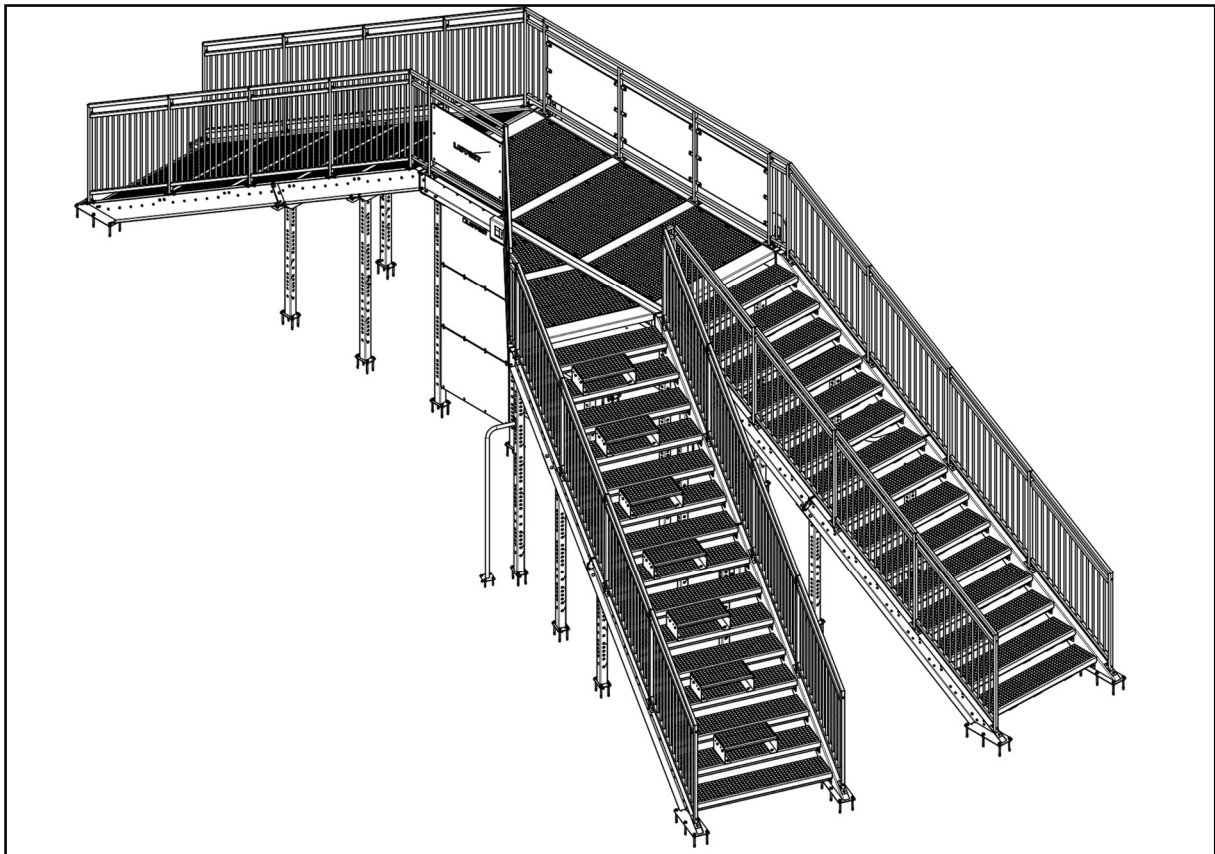
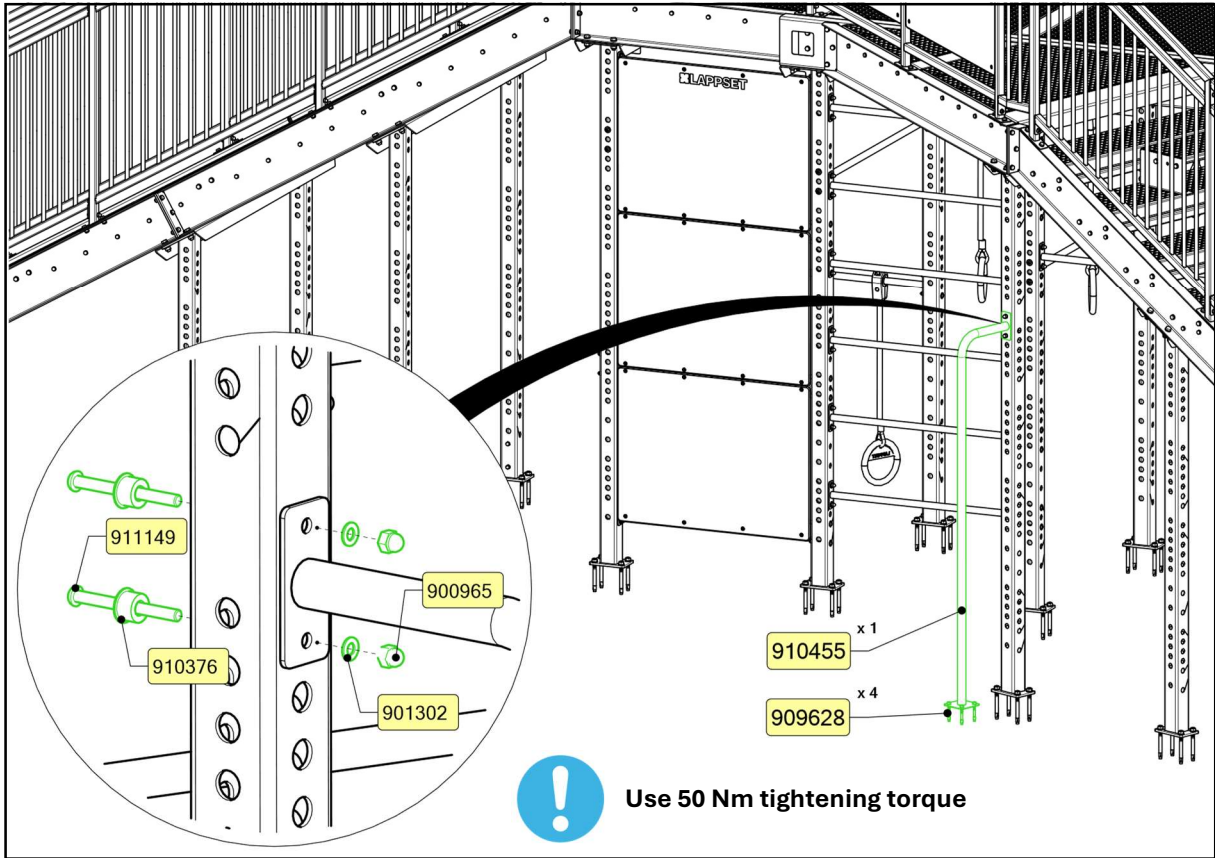

## SISU FITNESS STAIRS

### ABDOMINAL, BACK AND DIP MACHINE

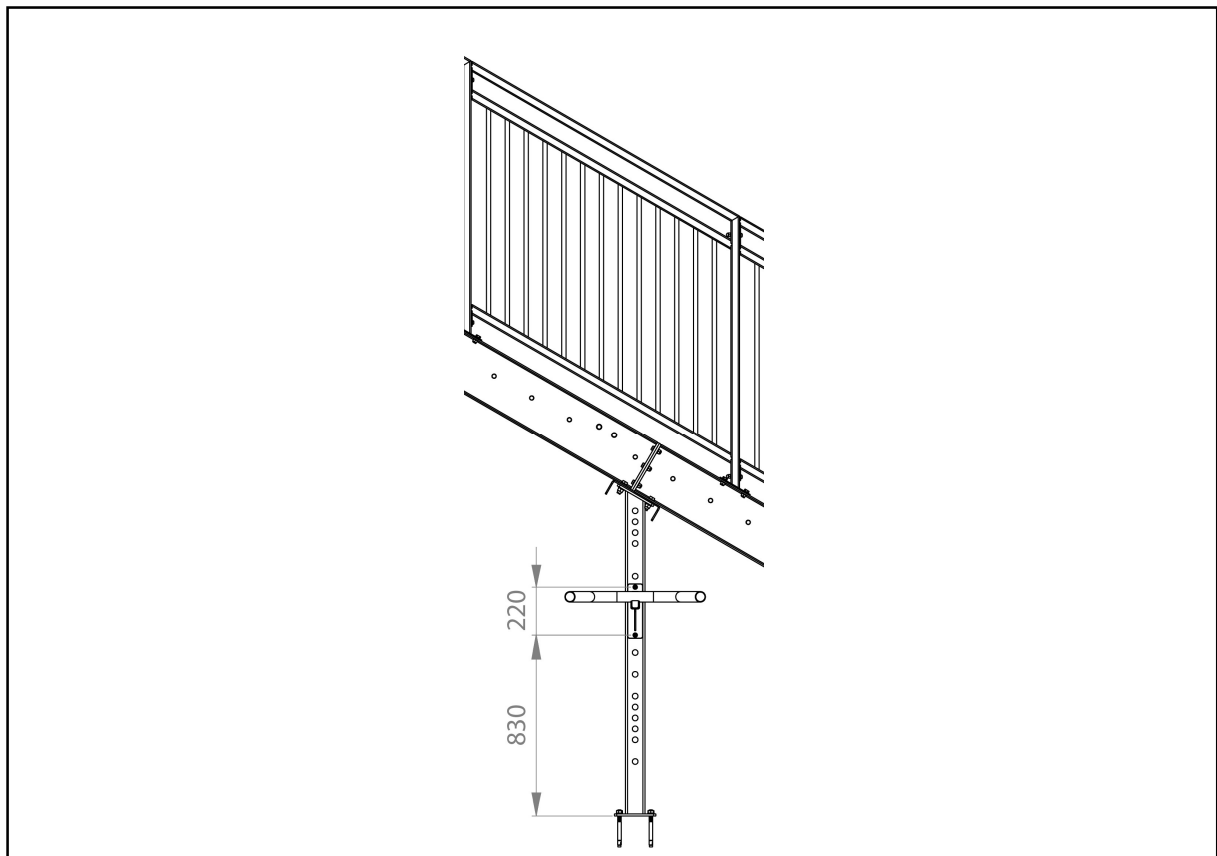
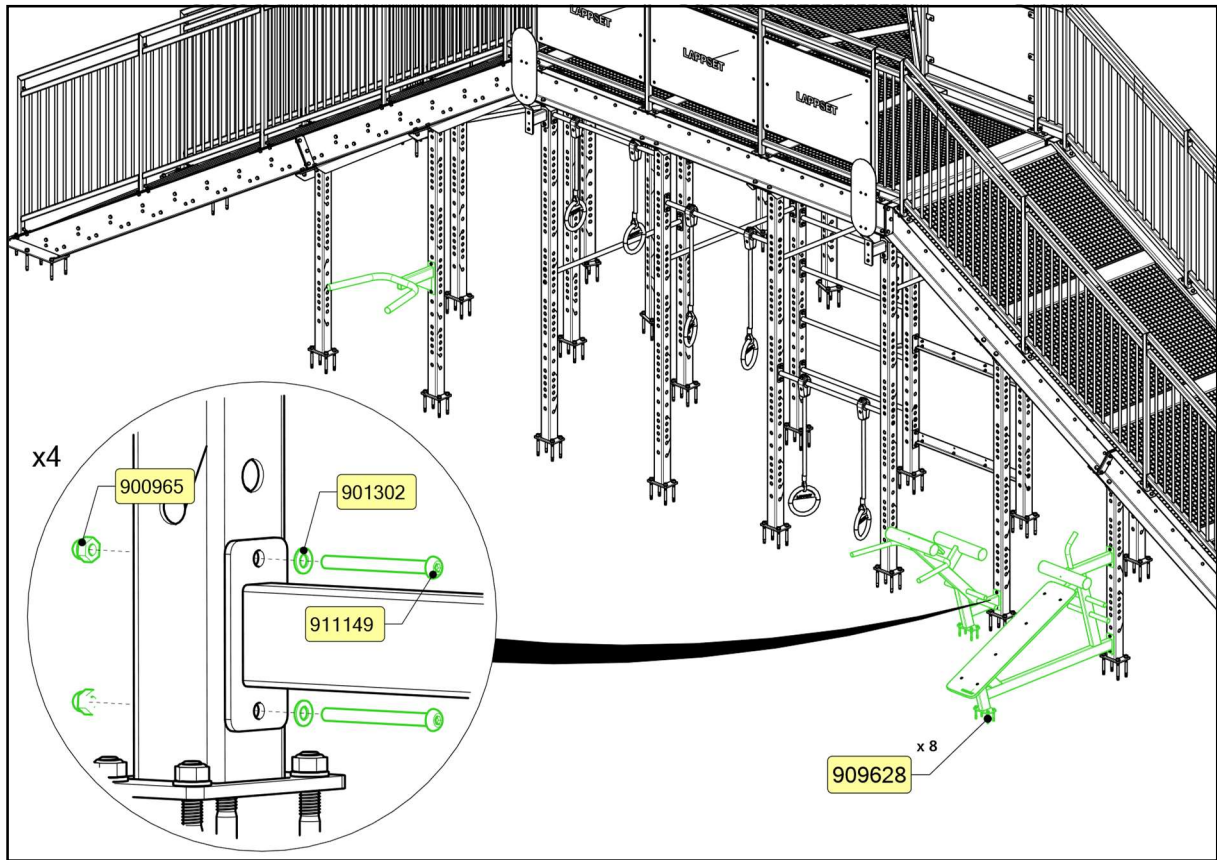

## SISU FITNESS STAIRS

### ABDOMINAL, BACK AND DIP MACHINE

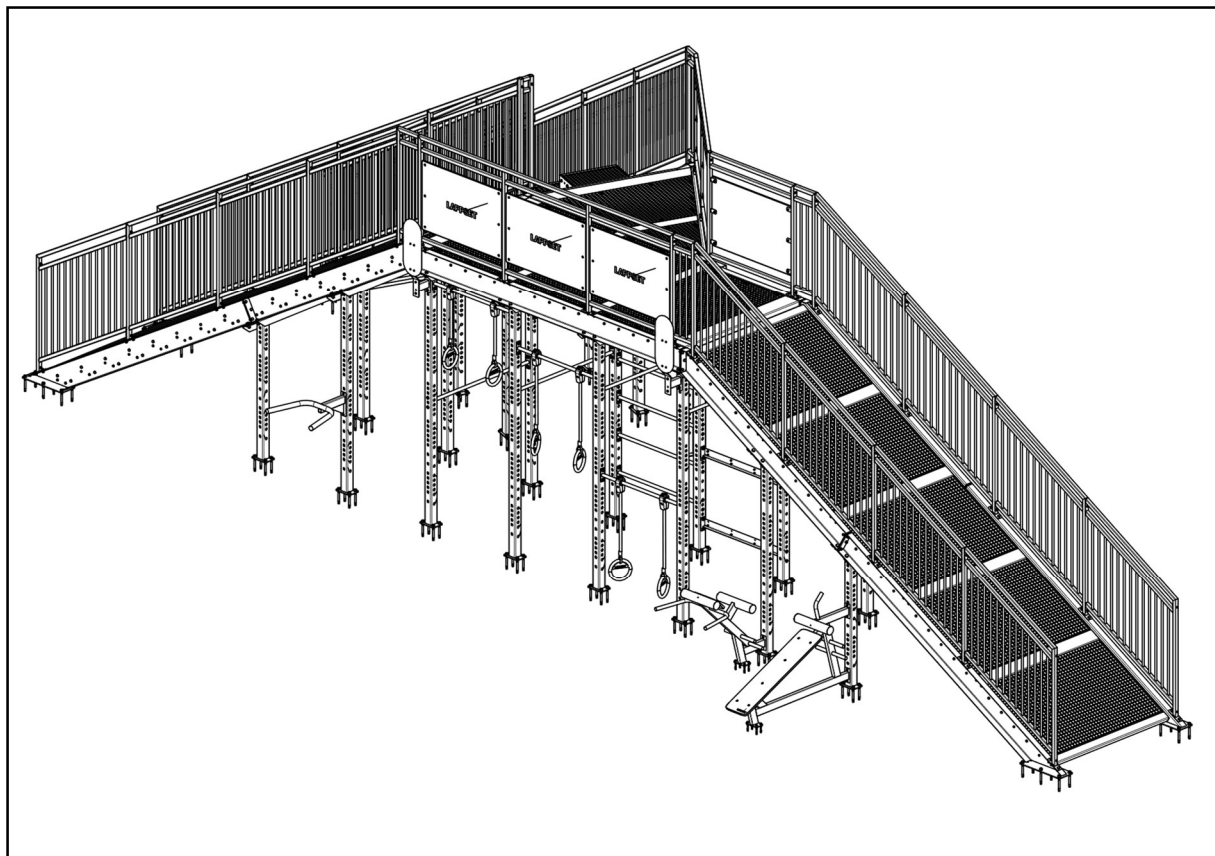
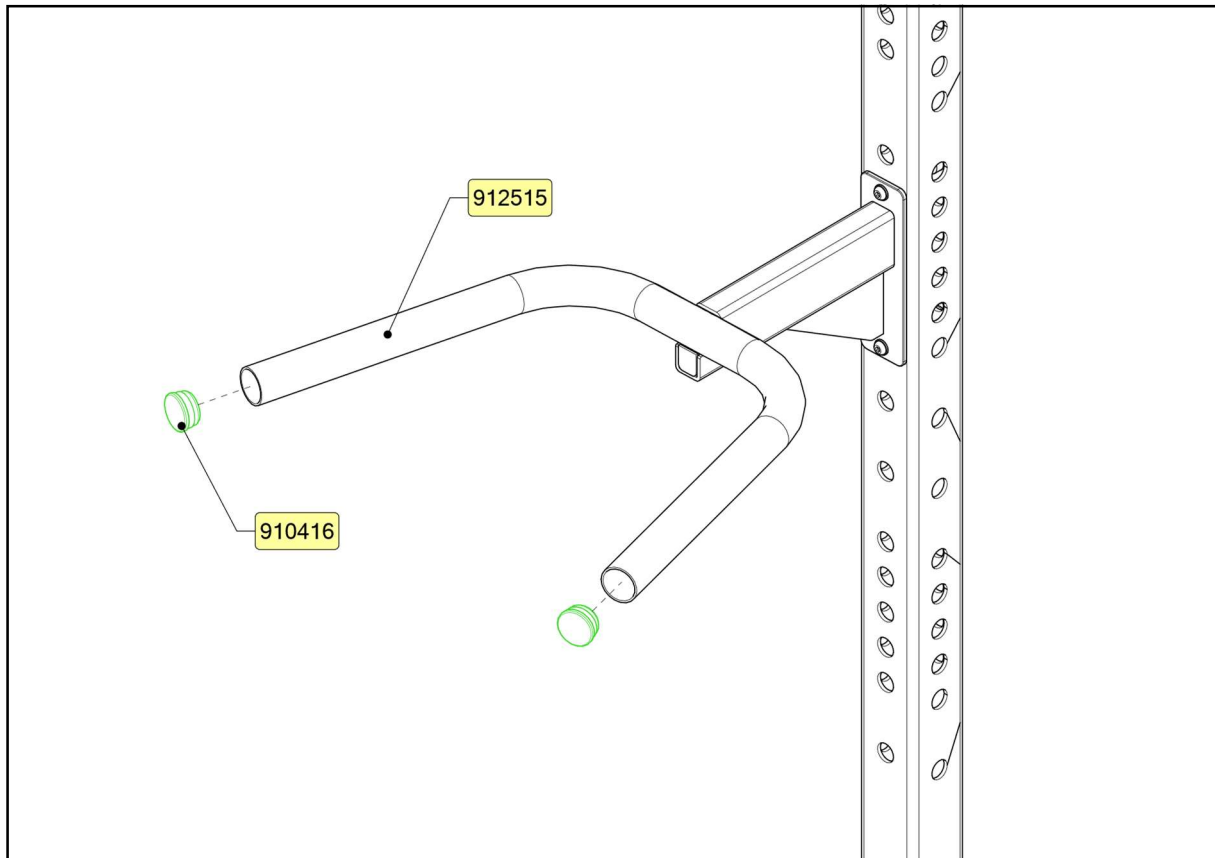

## SISU FITNESS STAIRS

### STAIR MARKS

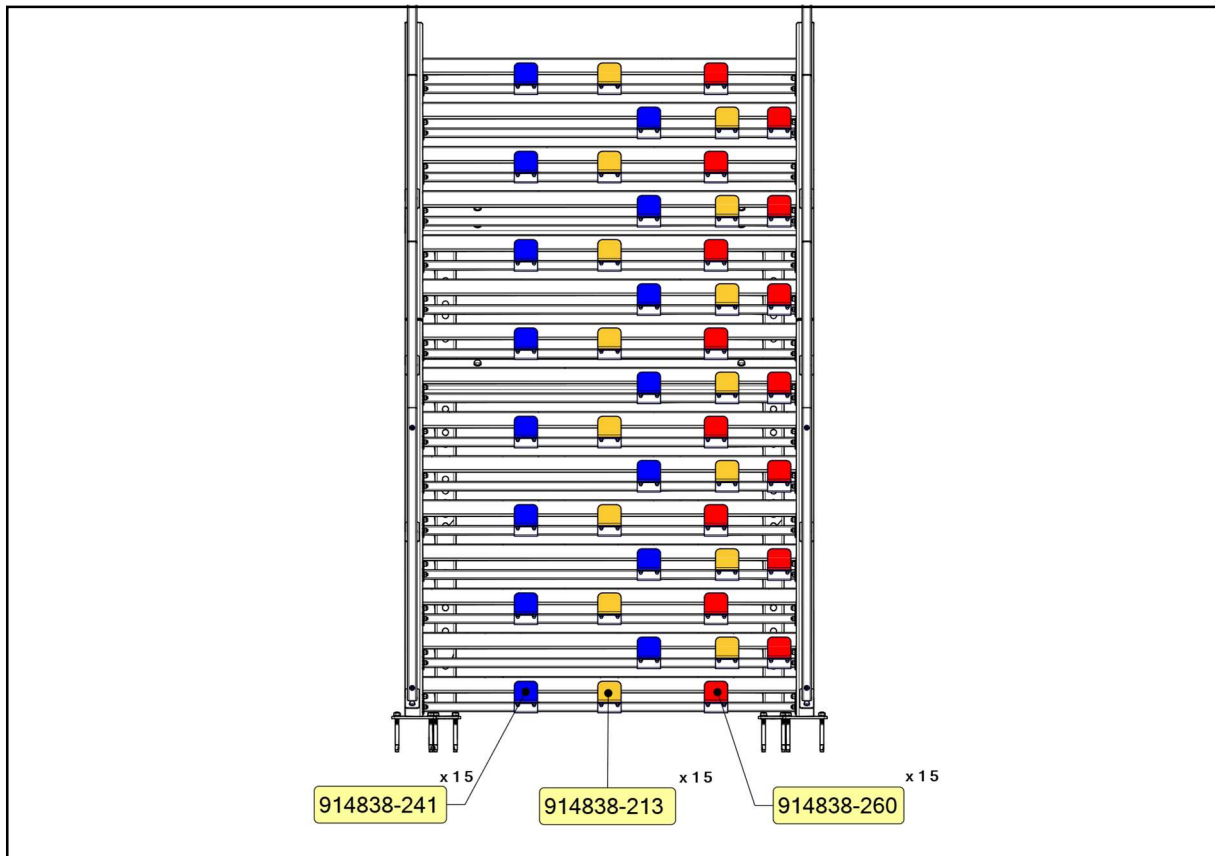
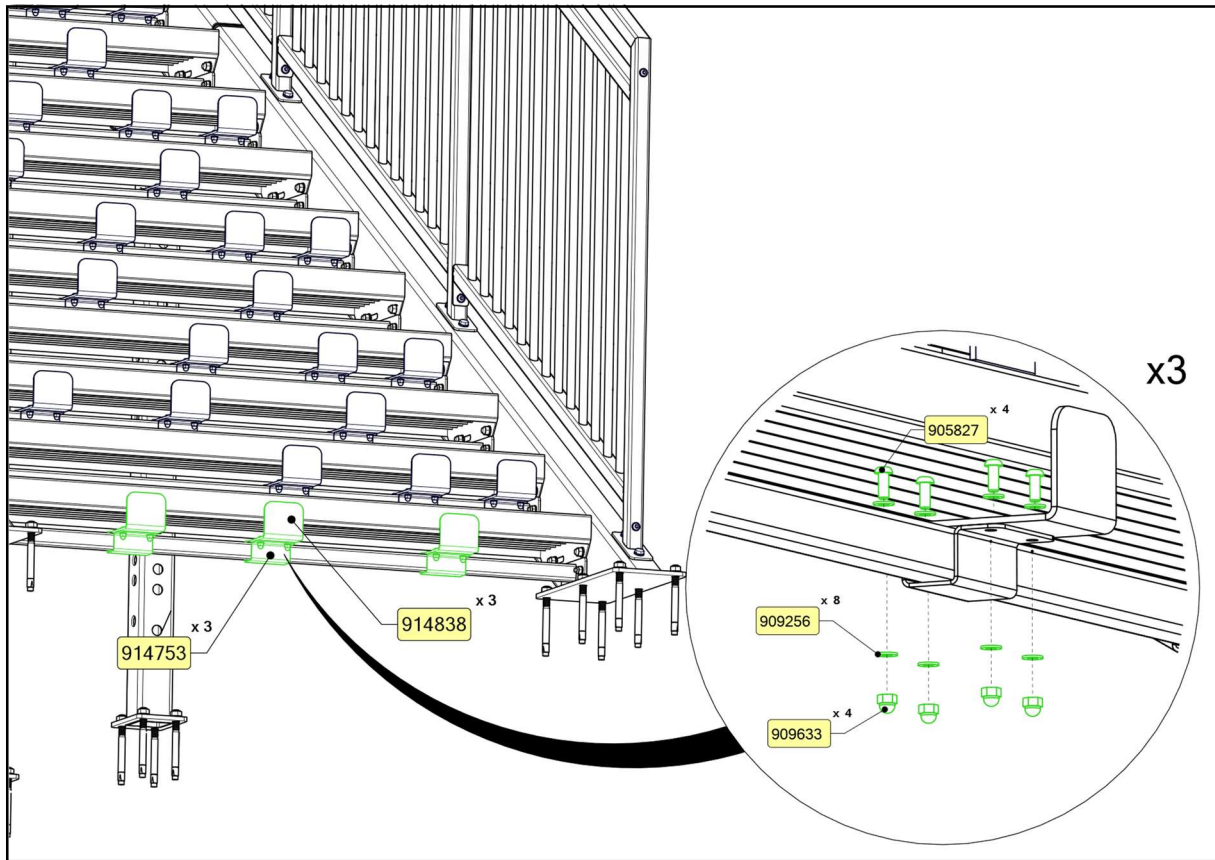

## SISU FITNESS STAIRS

### COUNTER

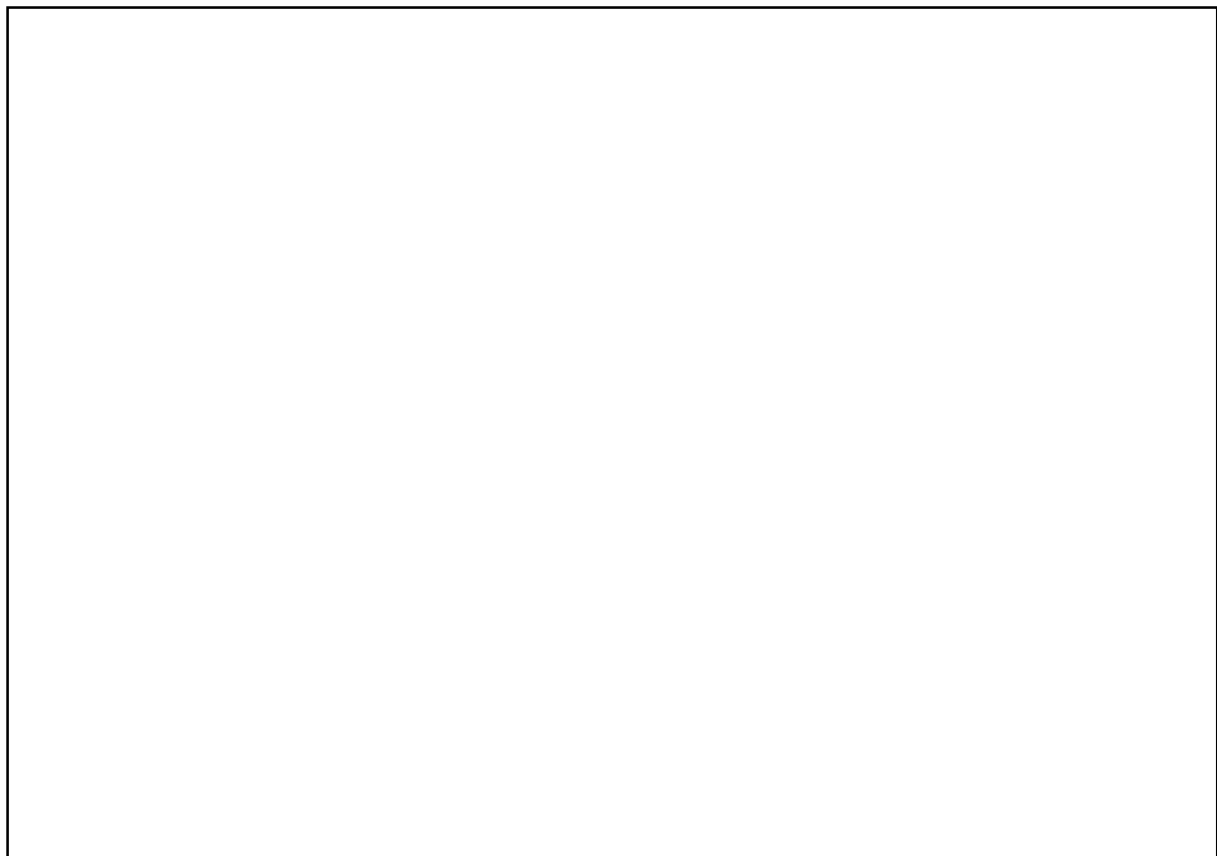
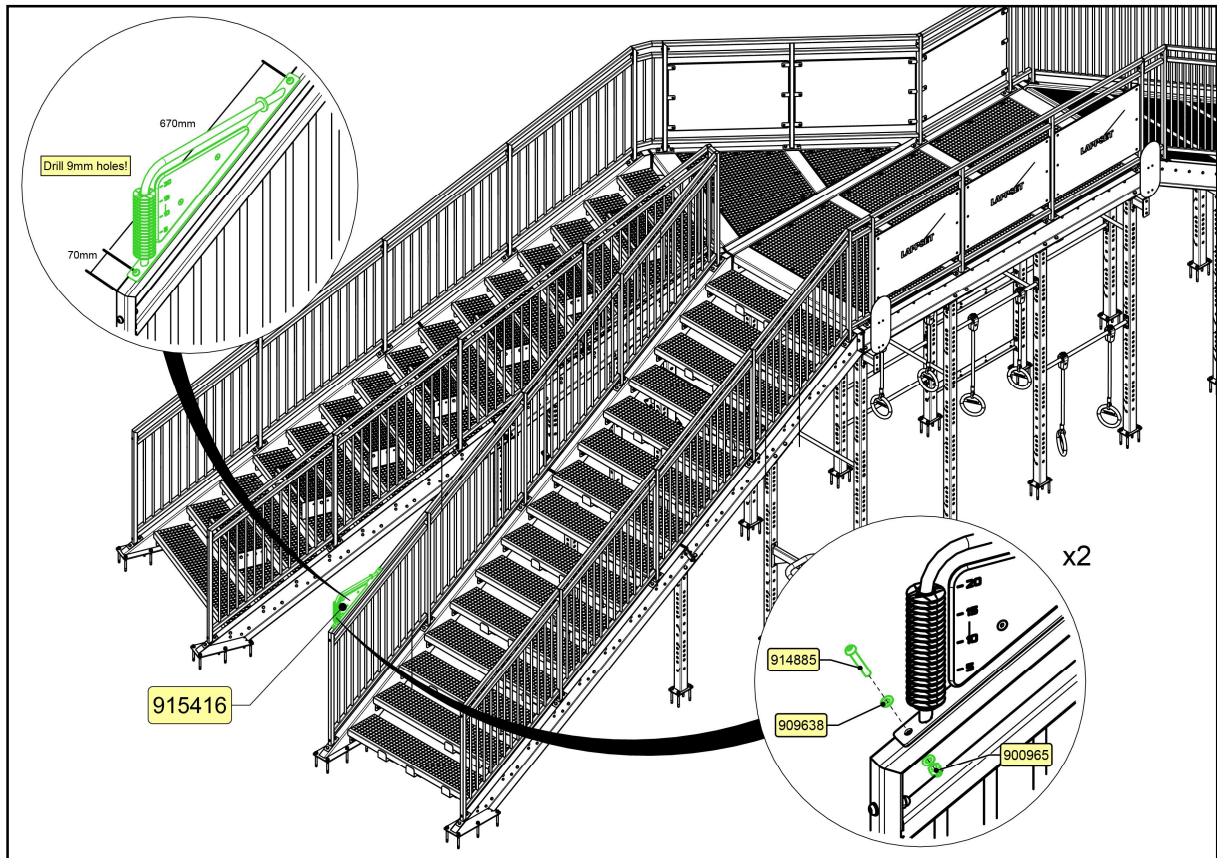

## SISU FITNESS STAIRS

### SIGNS

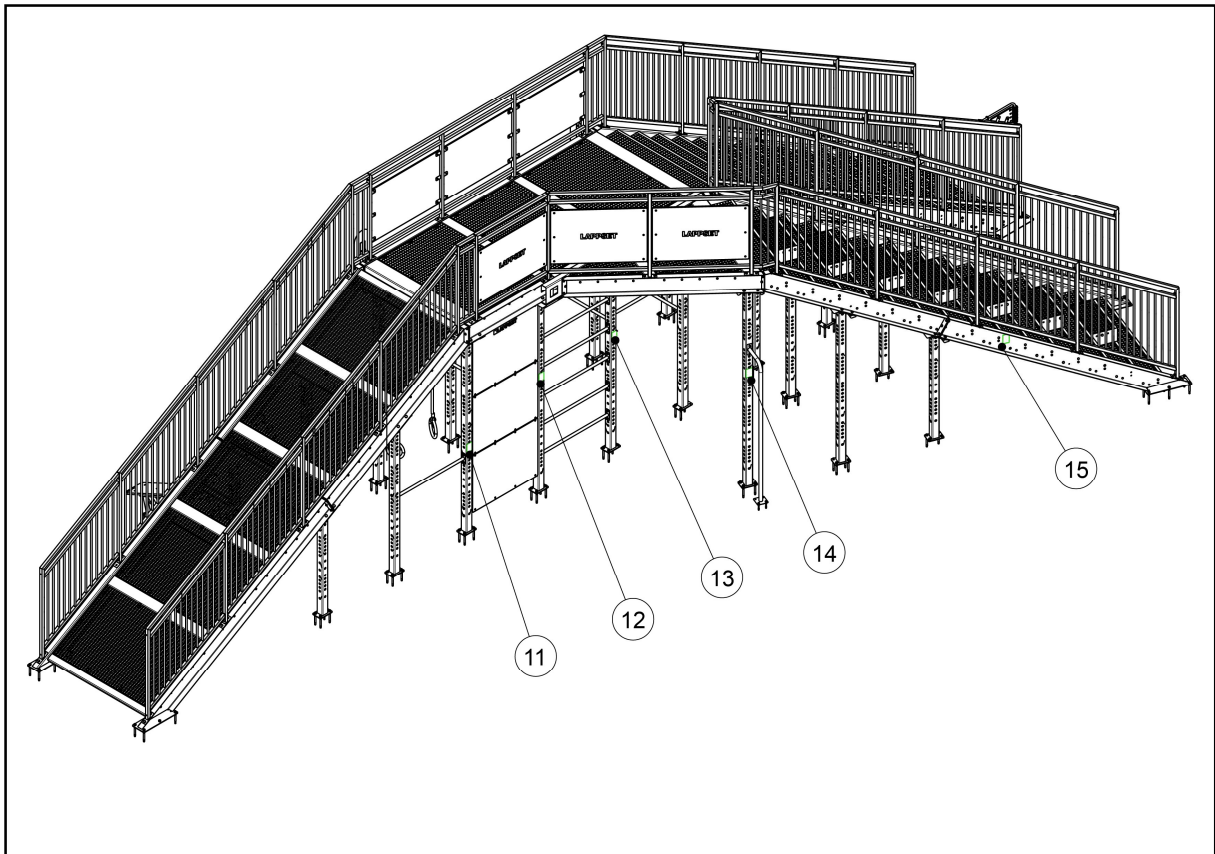
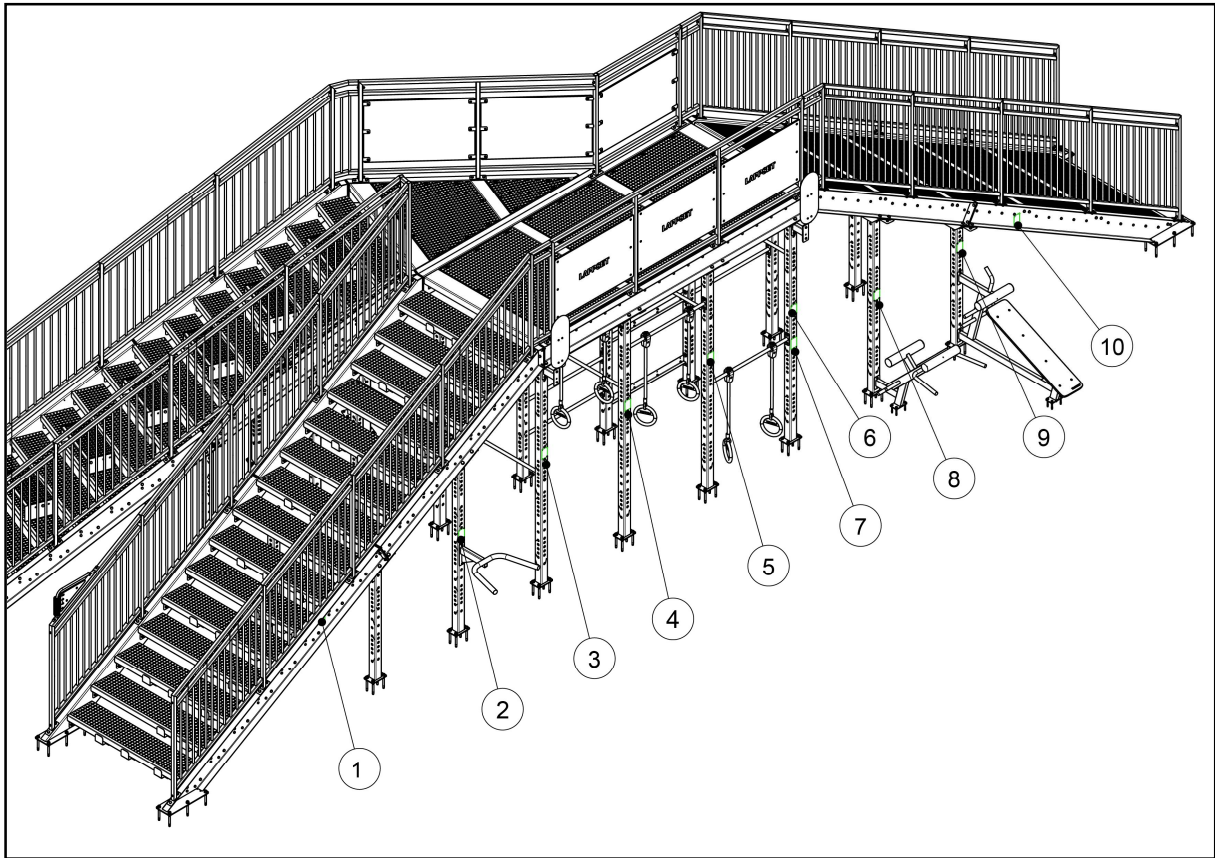

## SISU FITNESS STAIRS

### SIGN 1

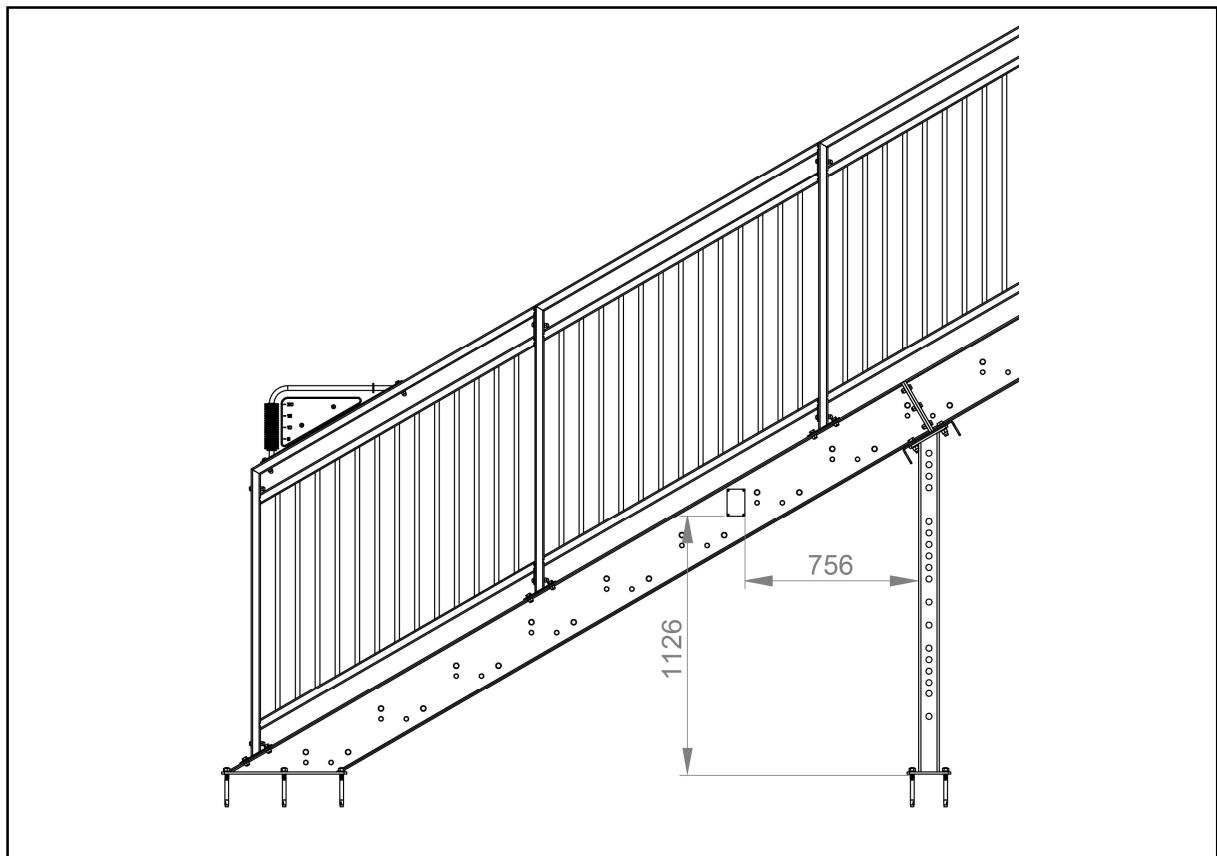
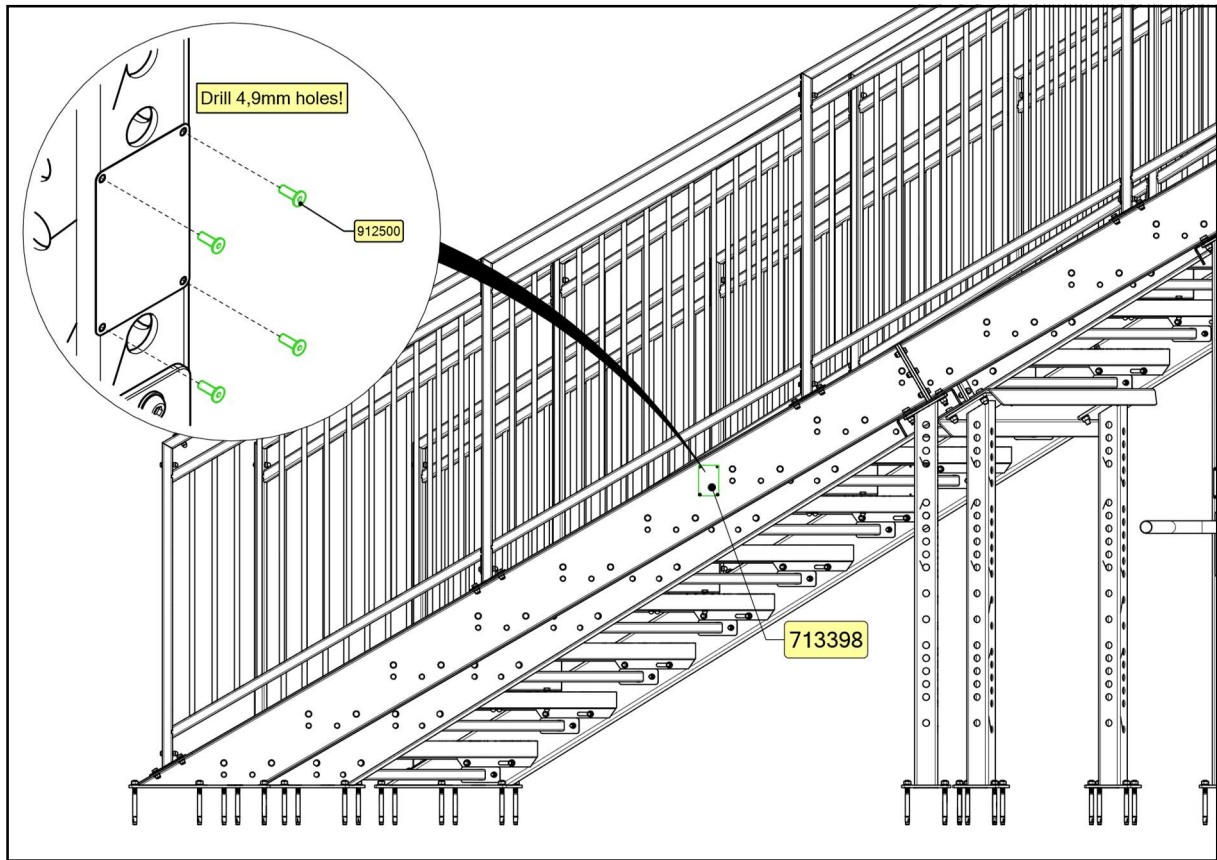

**SISU FITNESS STAIRS**

**SIGN 2**

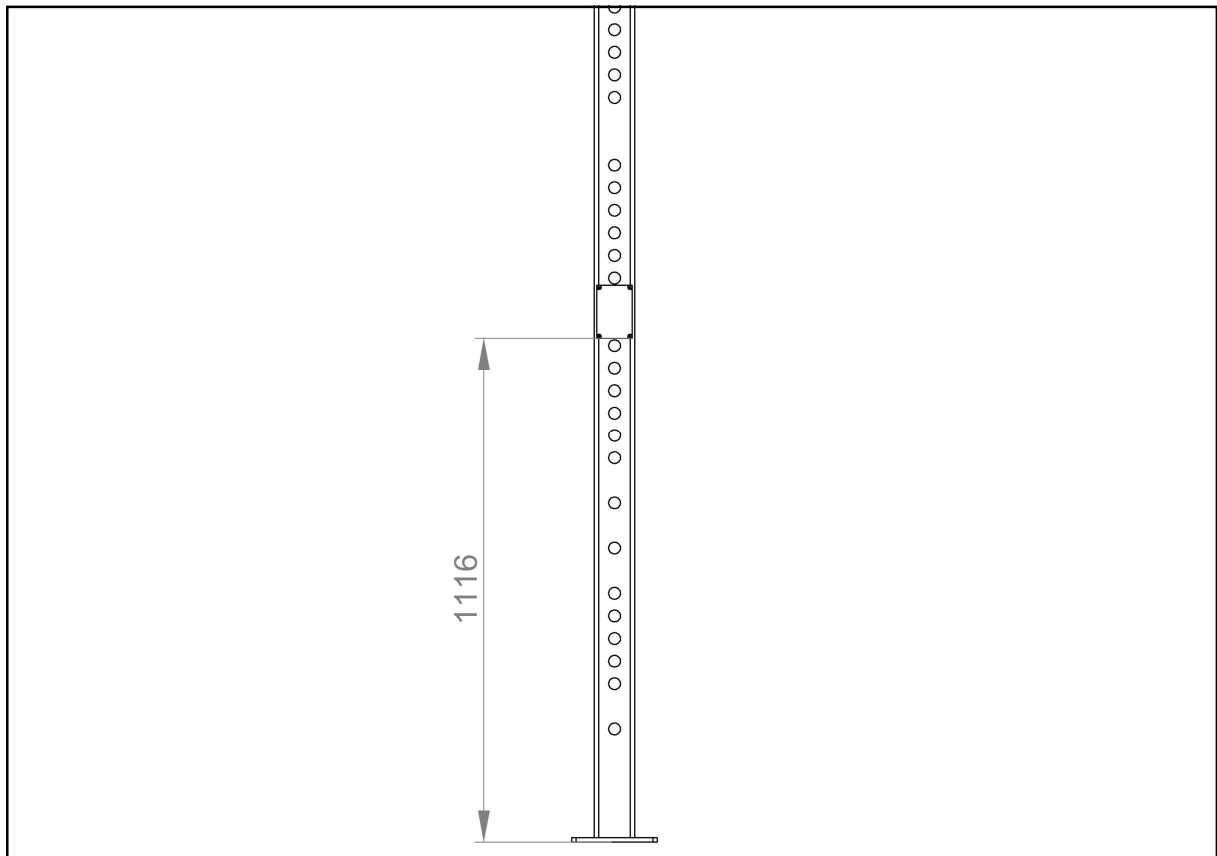
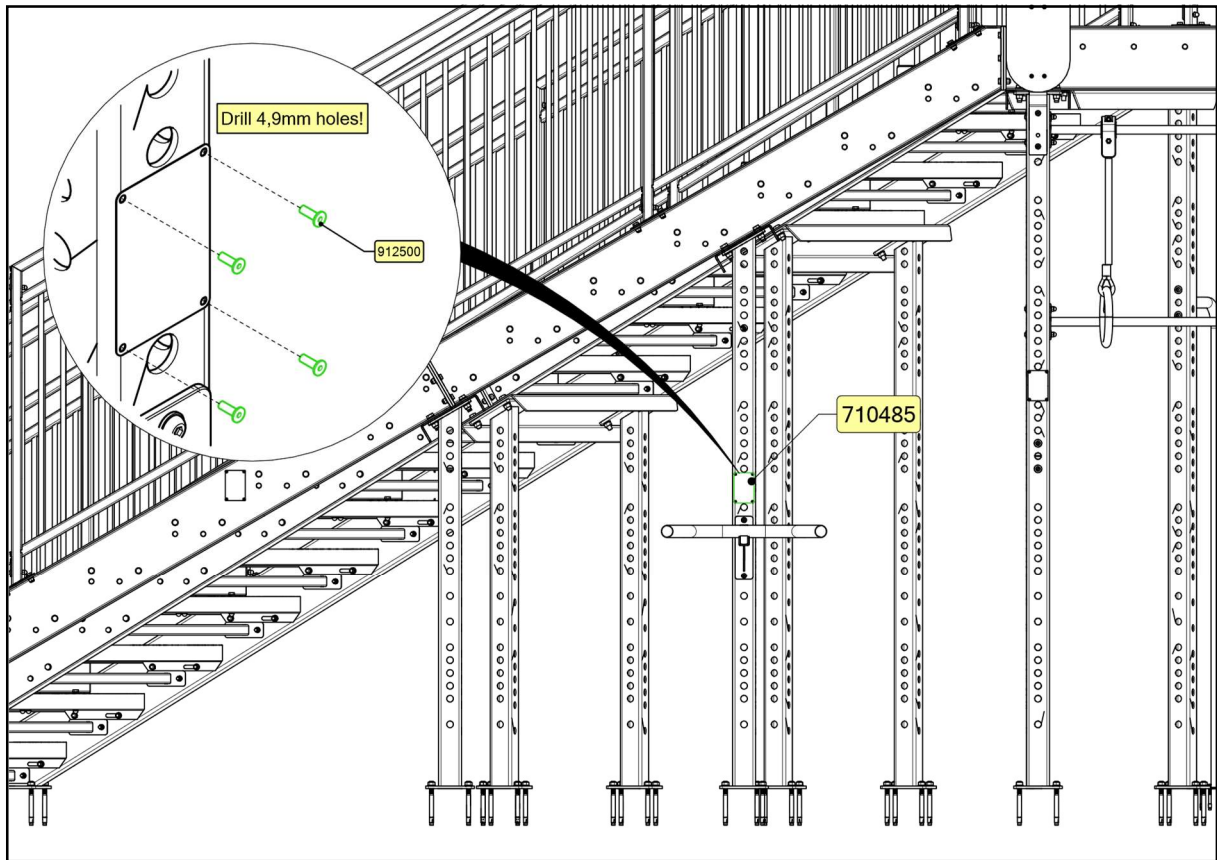

## SISU FITNESS STAIRS

### SIGN 3

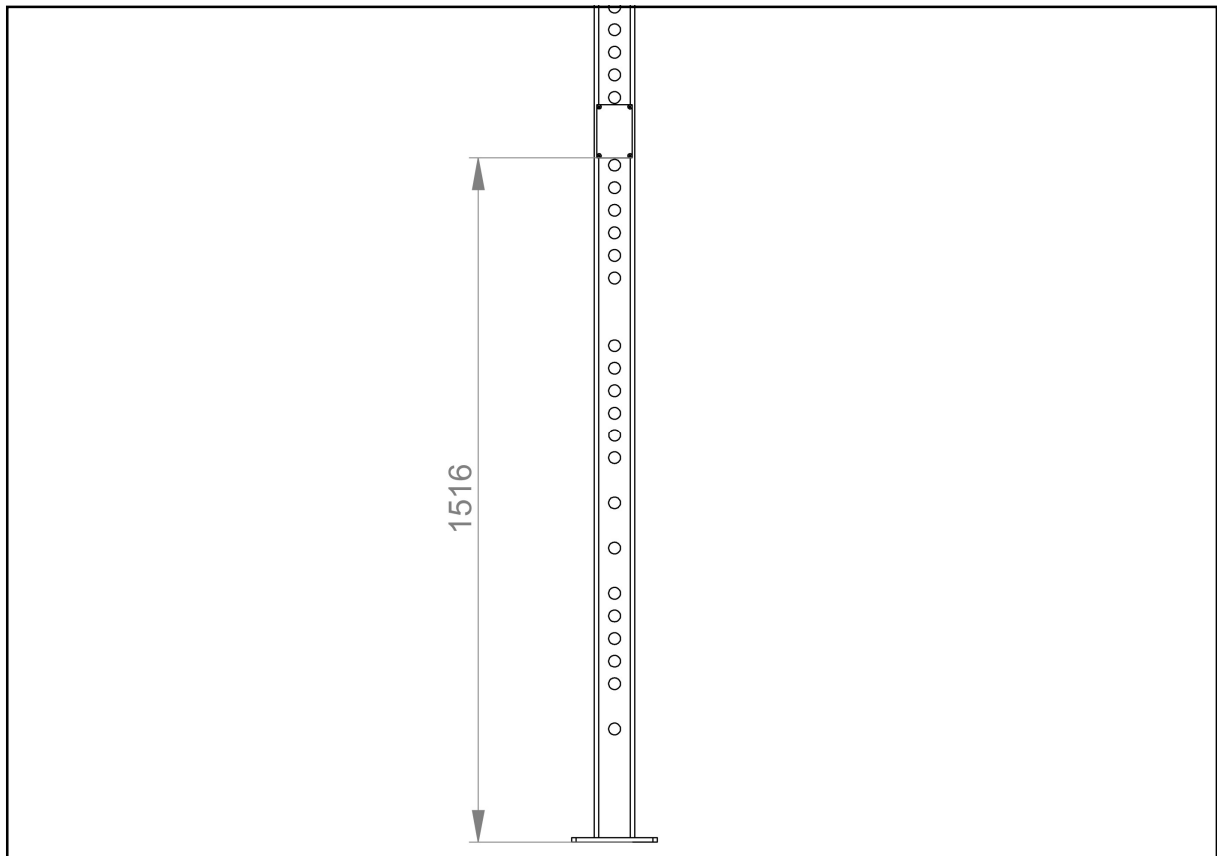
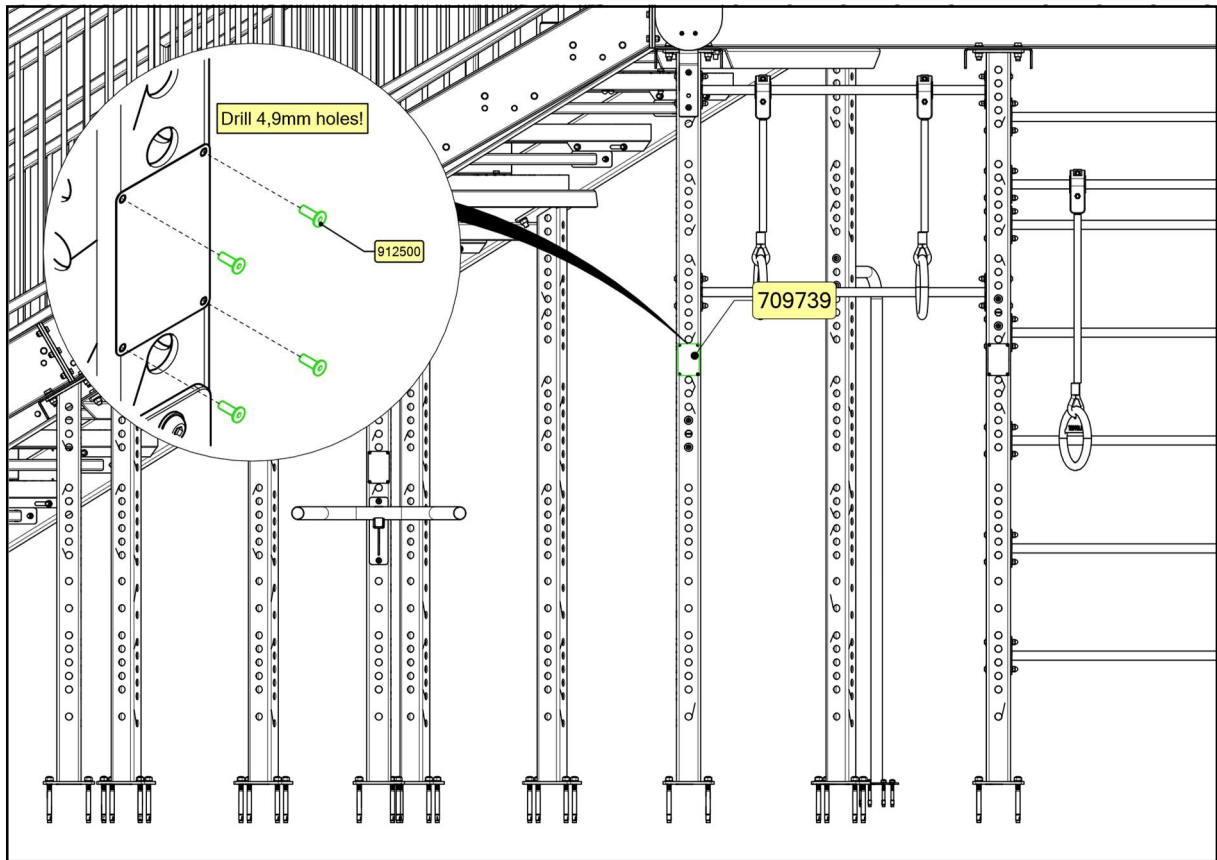

**SISU FITNESS STAIRS**

**SIGN 4**

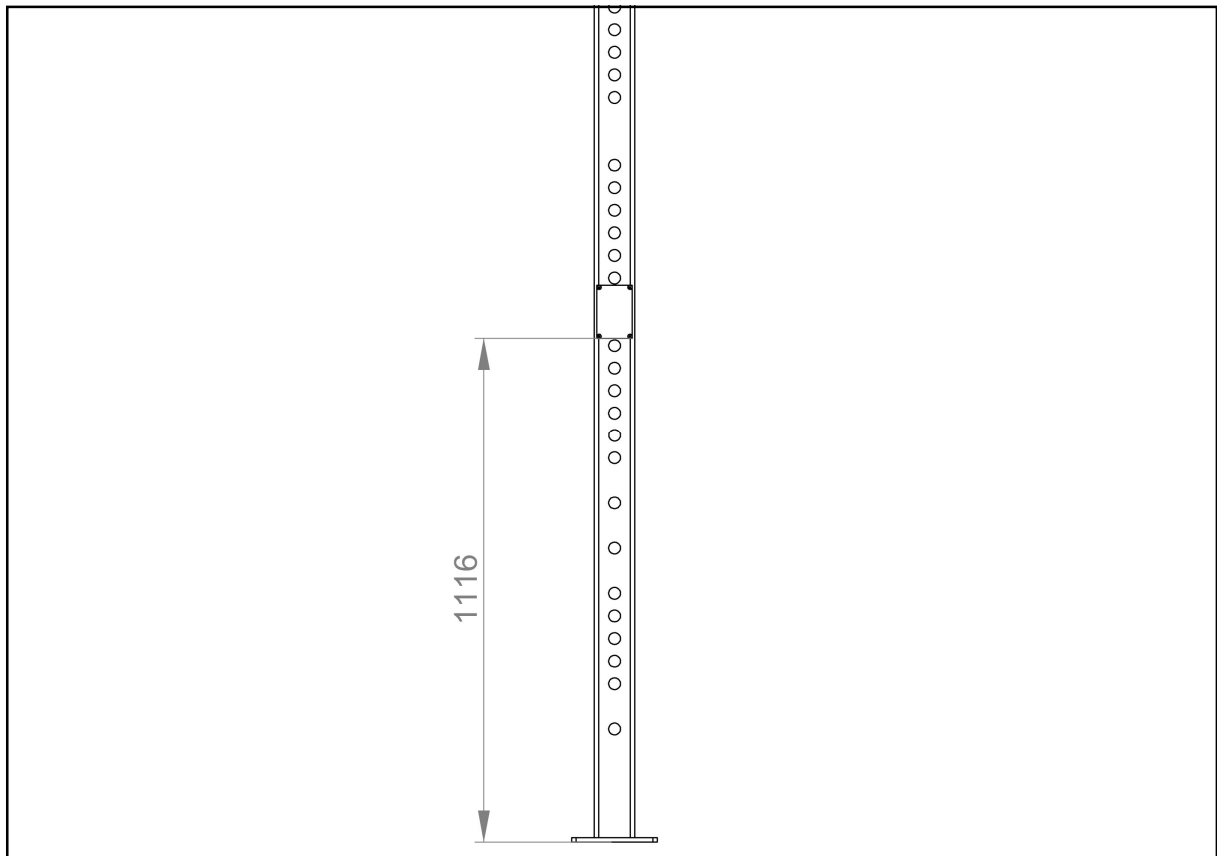
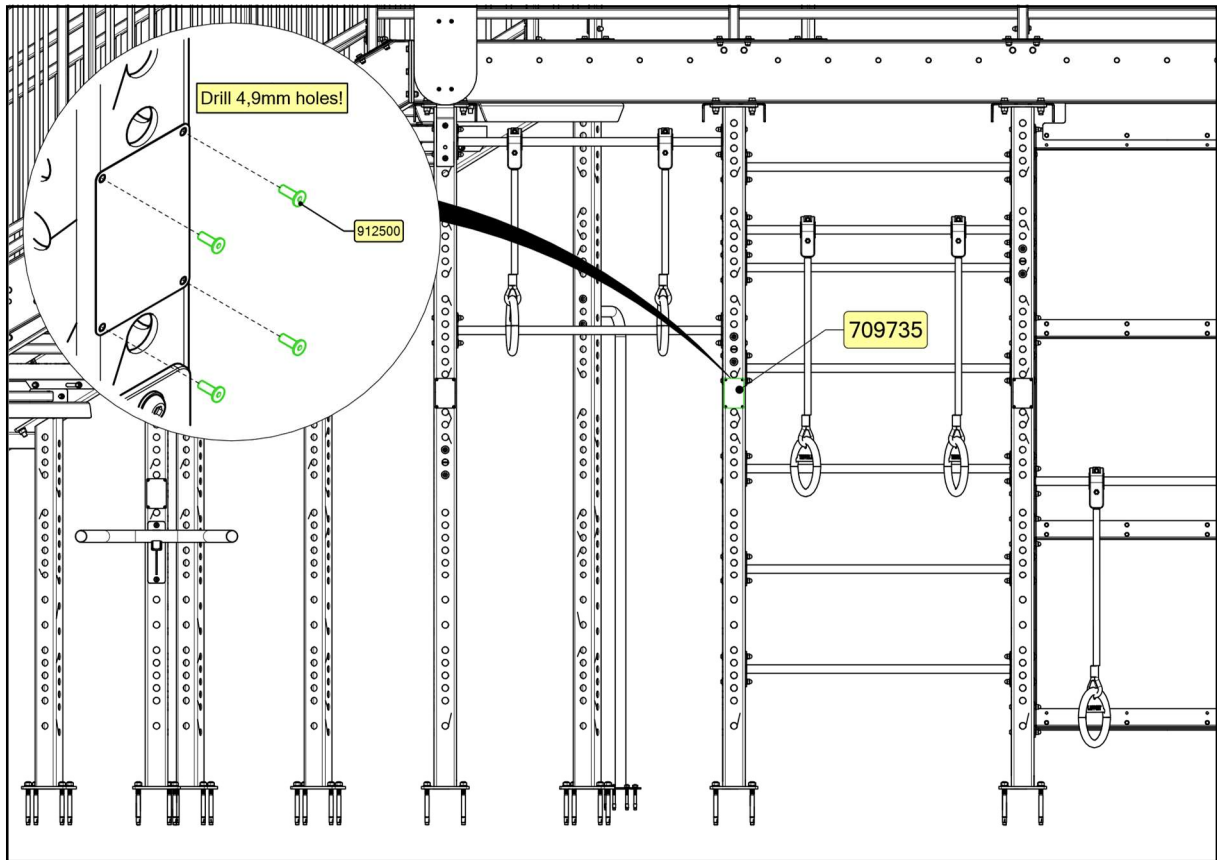

## SISU FITNESS STAIRS

### SIGN 5

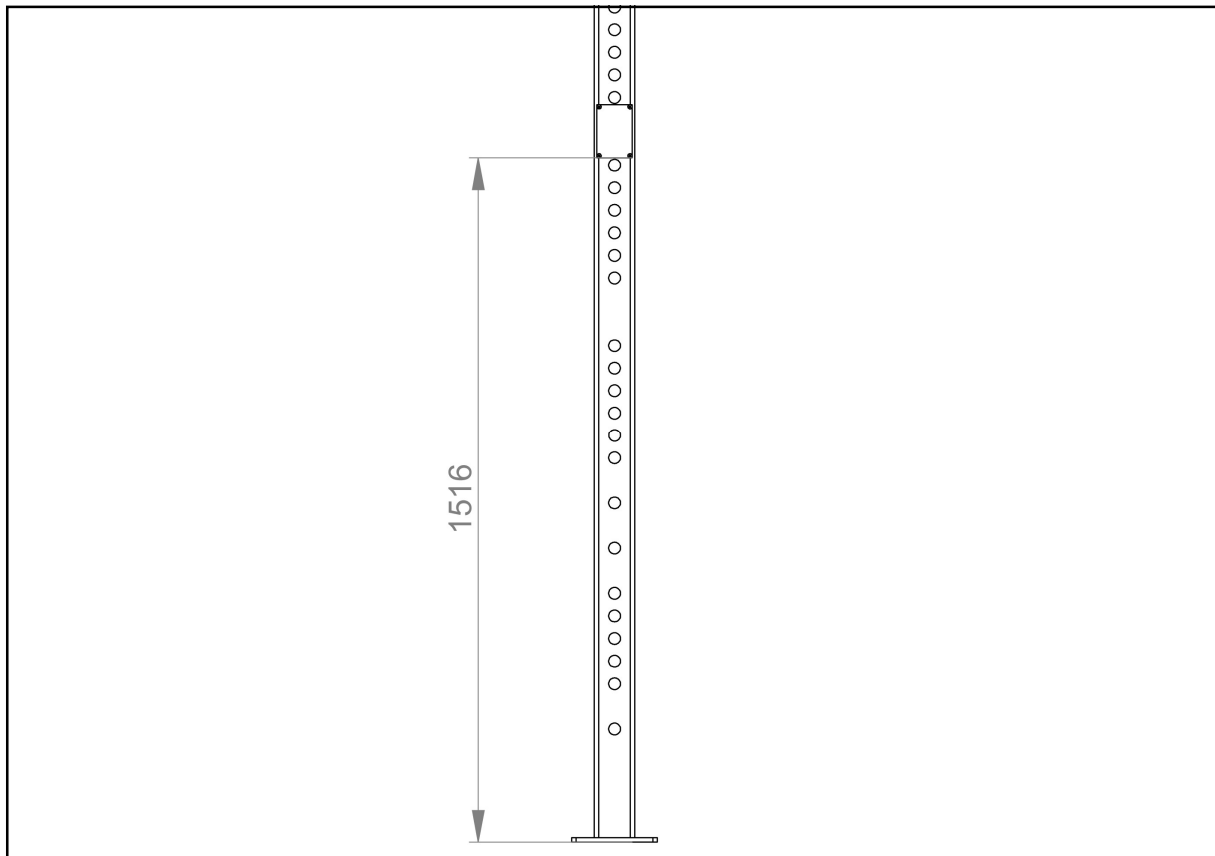
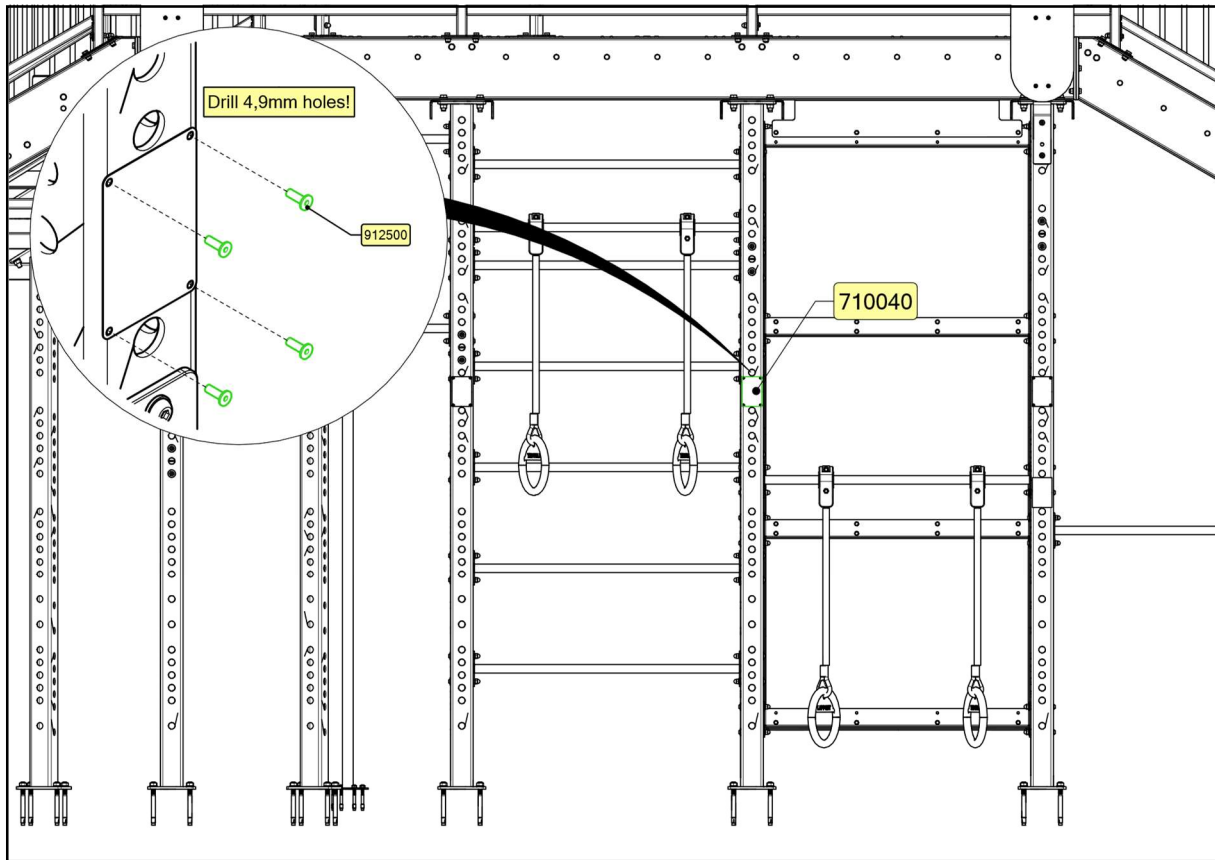

## SISU FITNESS STAIRS

### SIGN 6-7

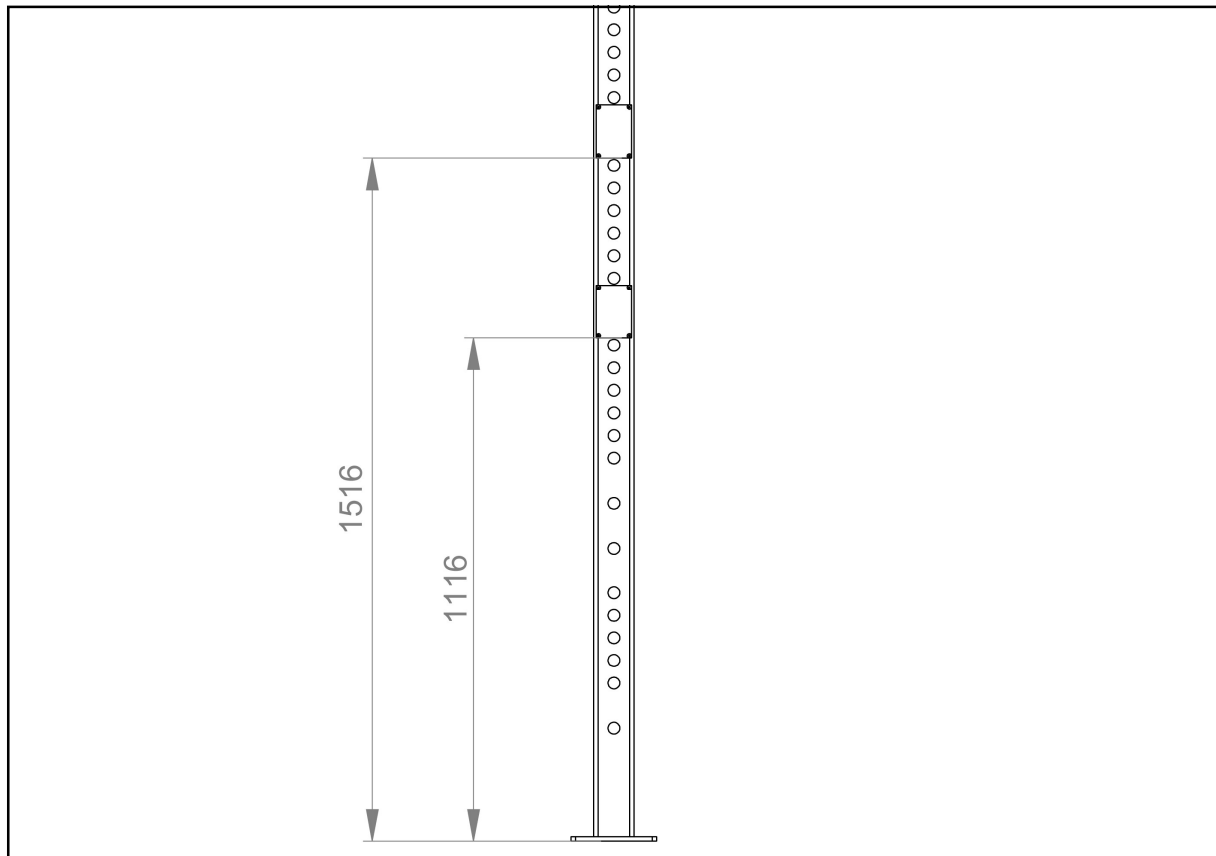
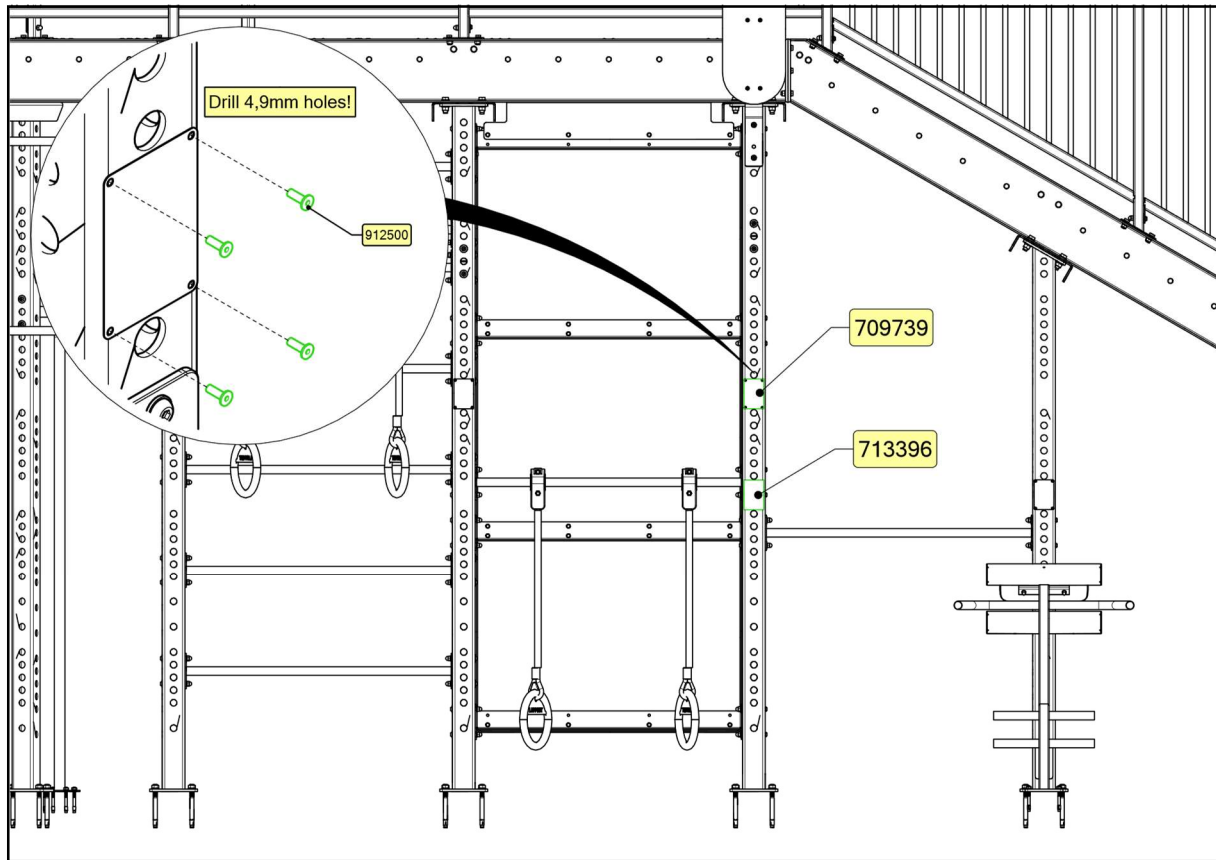

## SISU FITNESS STAIRS

### SIGN 8

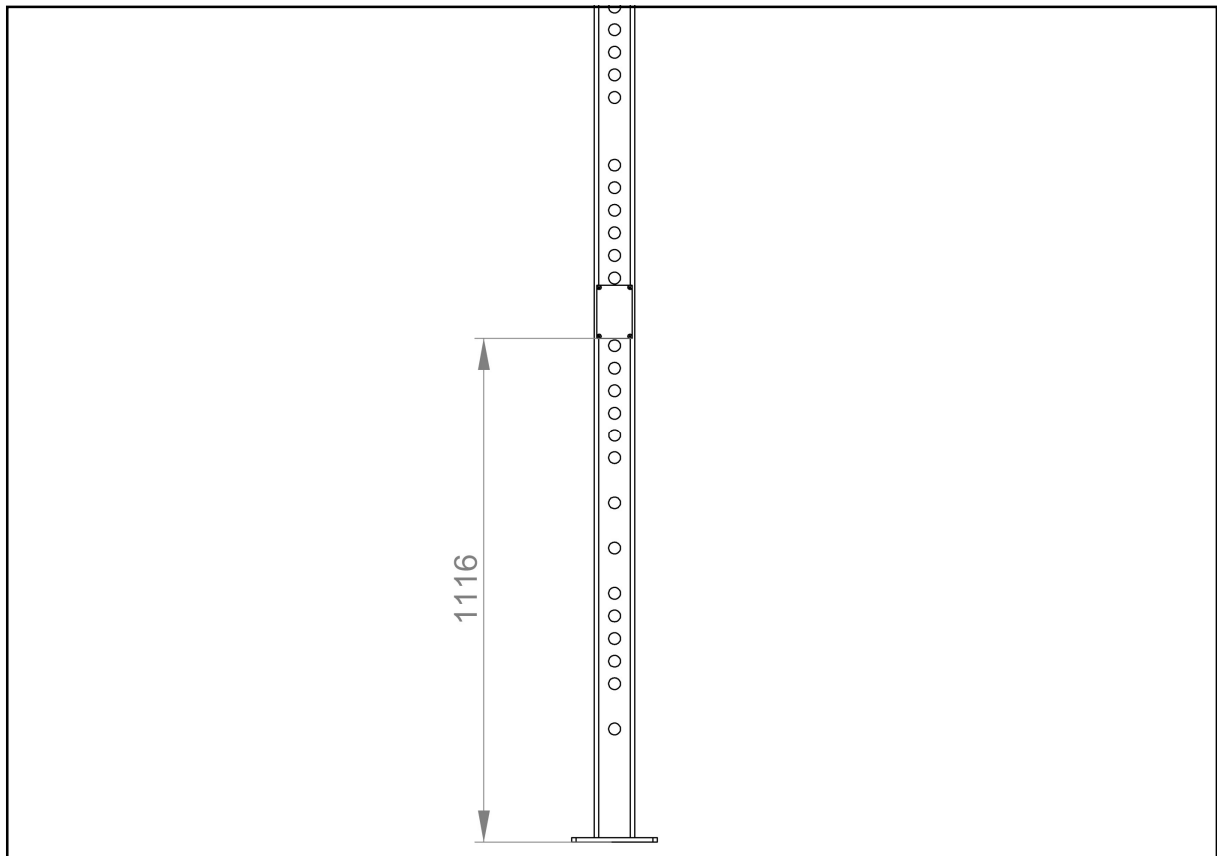
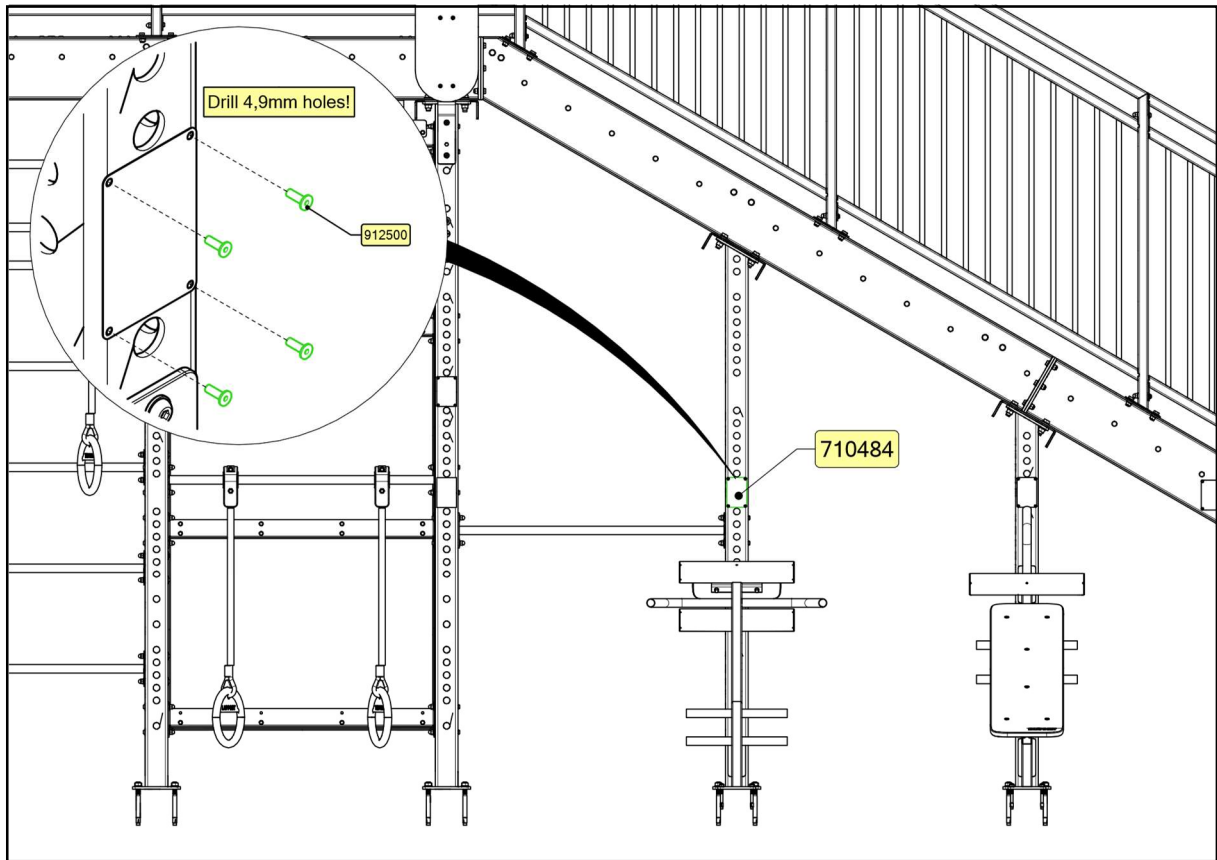

## SISU FITNESS STAIRS

### SIGN 9

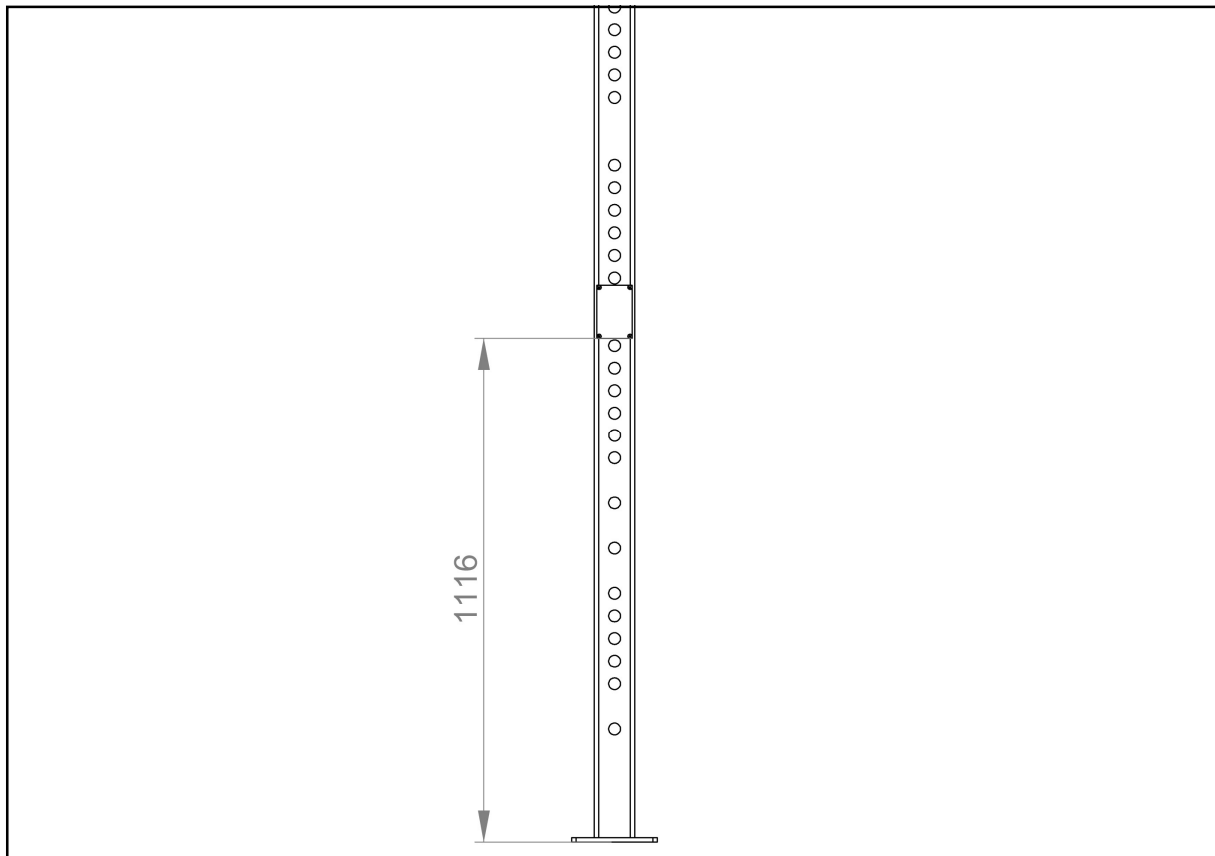
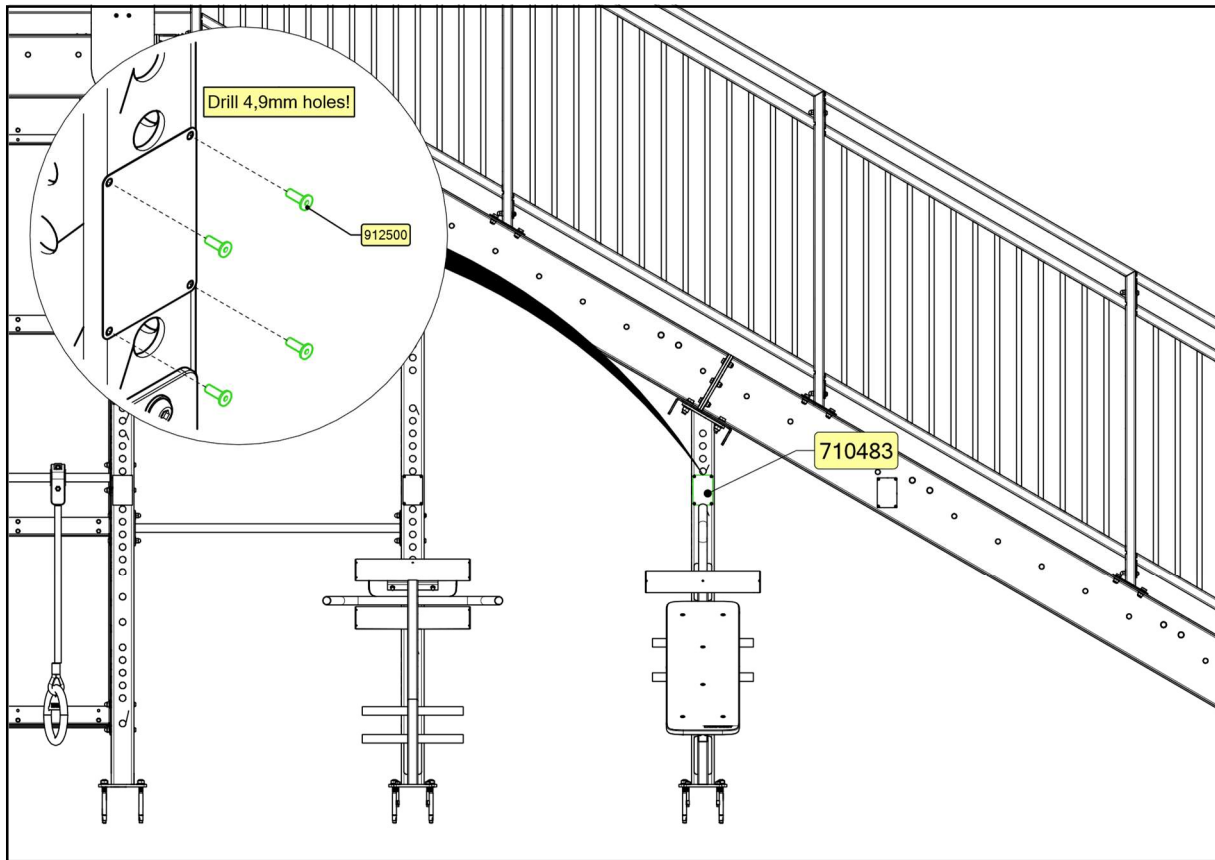

## SISU FITNESS STAIRS

### SIGN 10

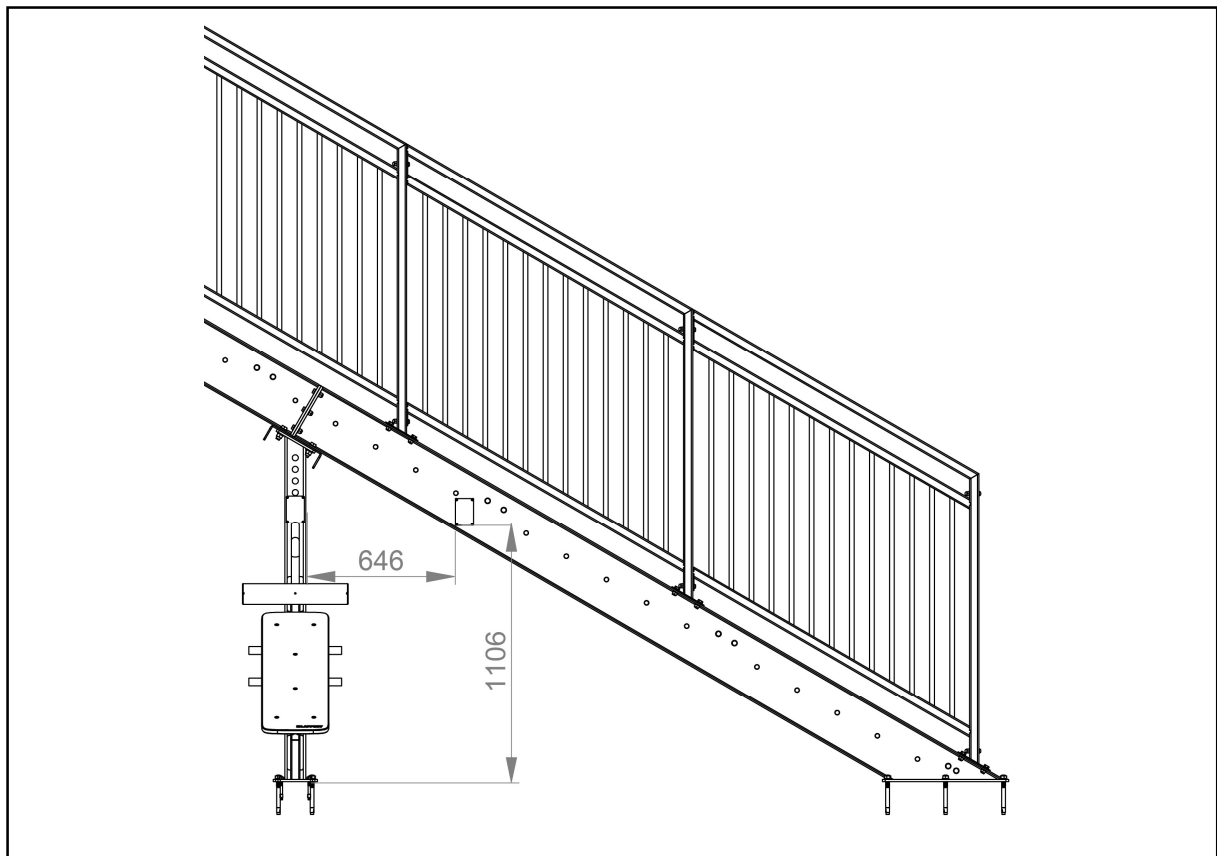
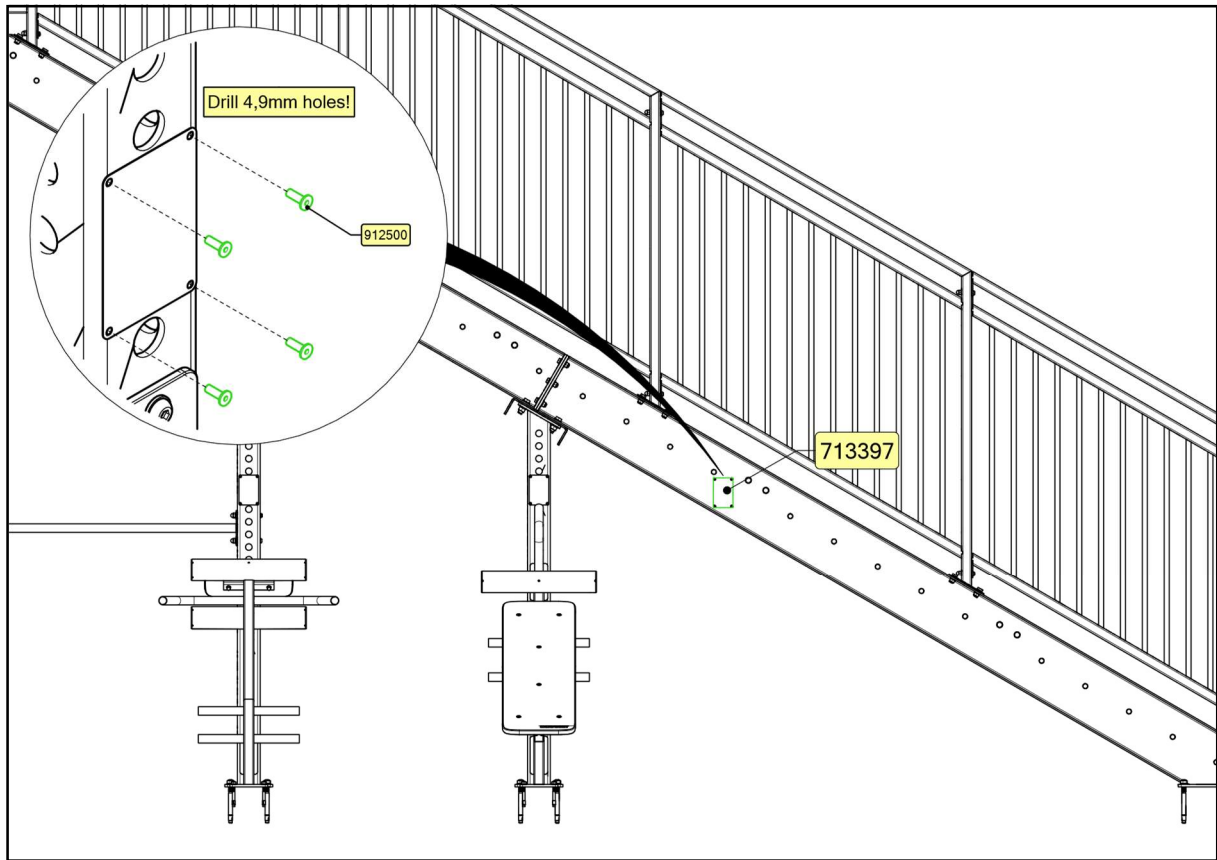

## SISU FITNESS STAIRS

### SIGN 11

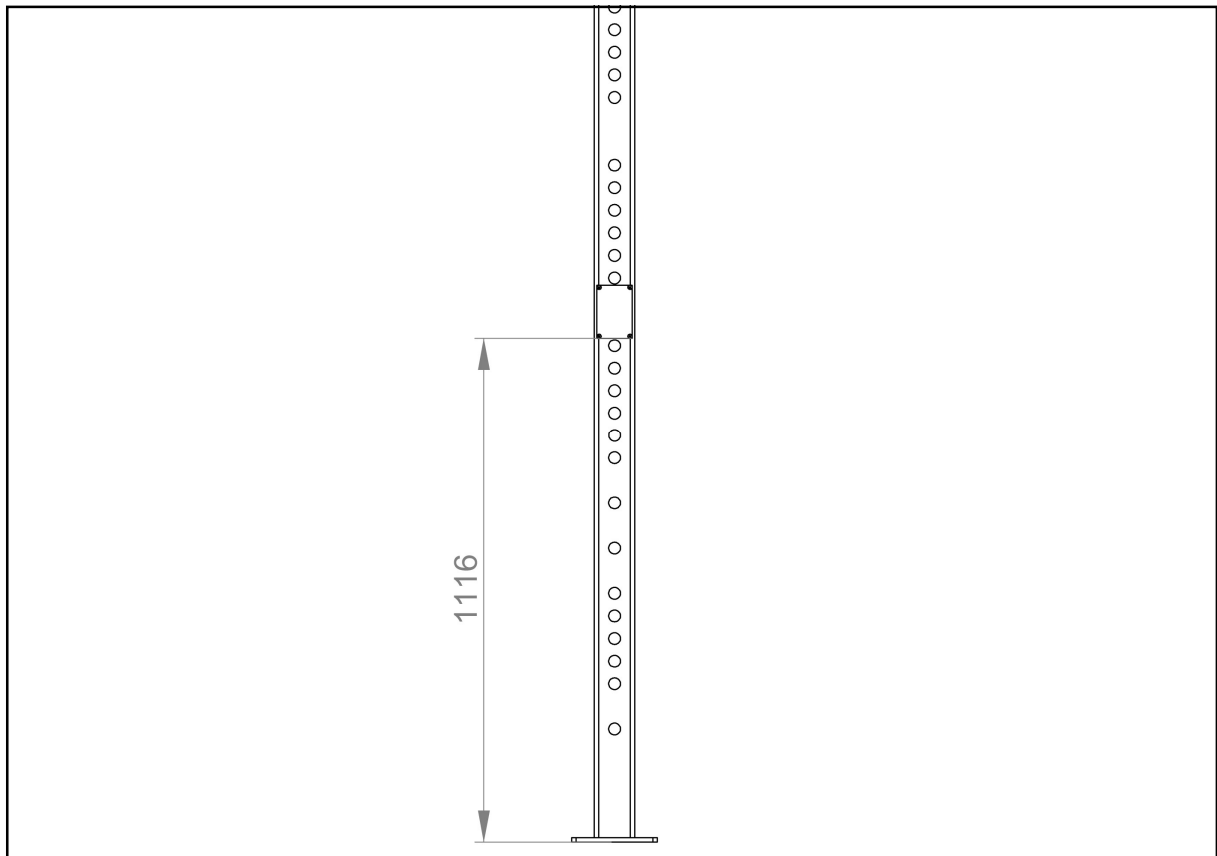
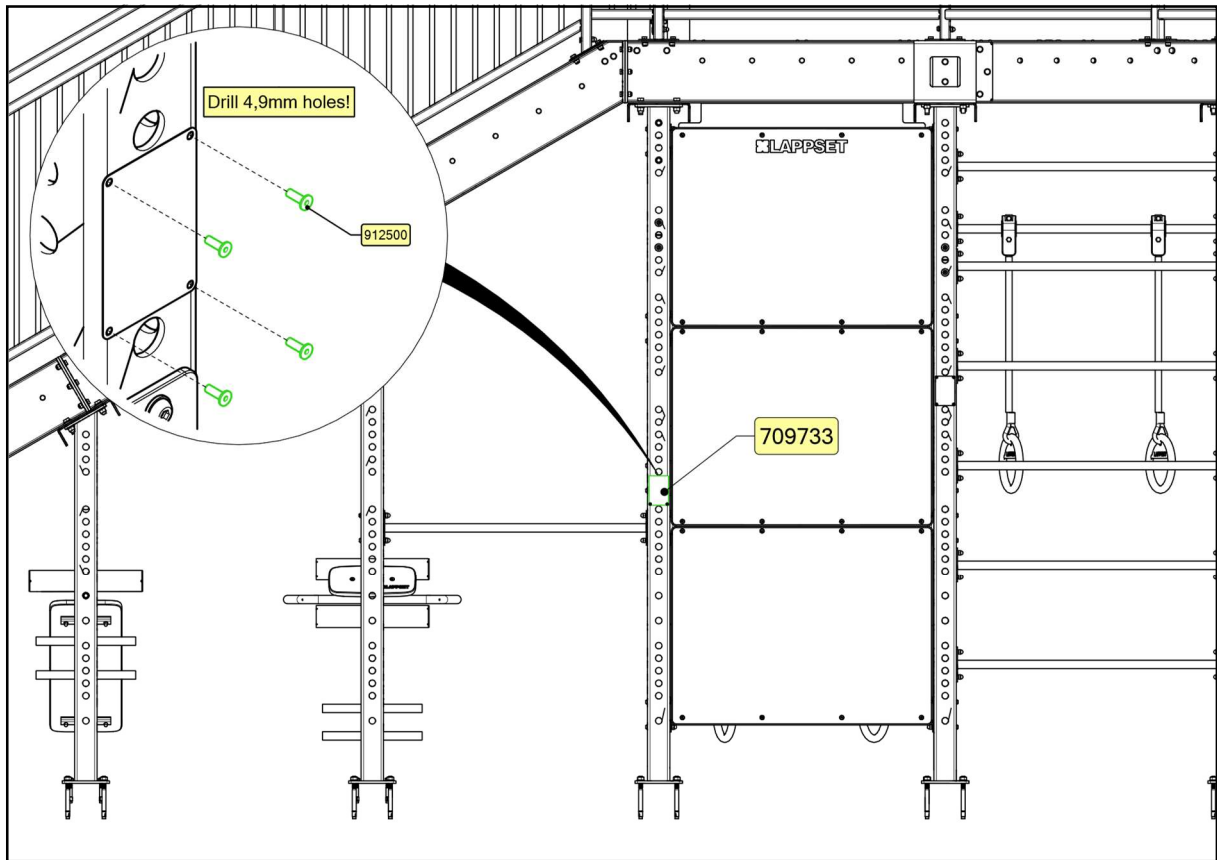

## SISU FITNESS STAIRS

### SIGN 12

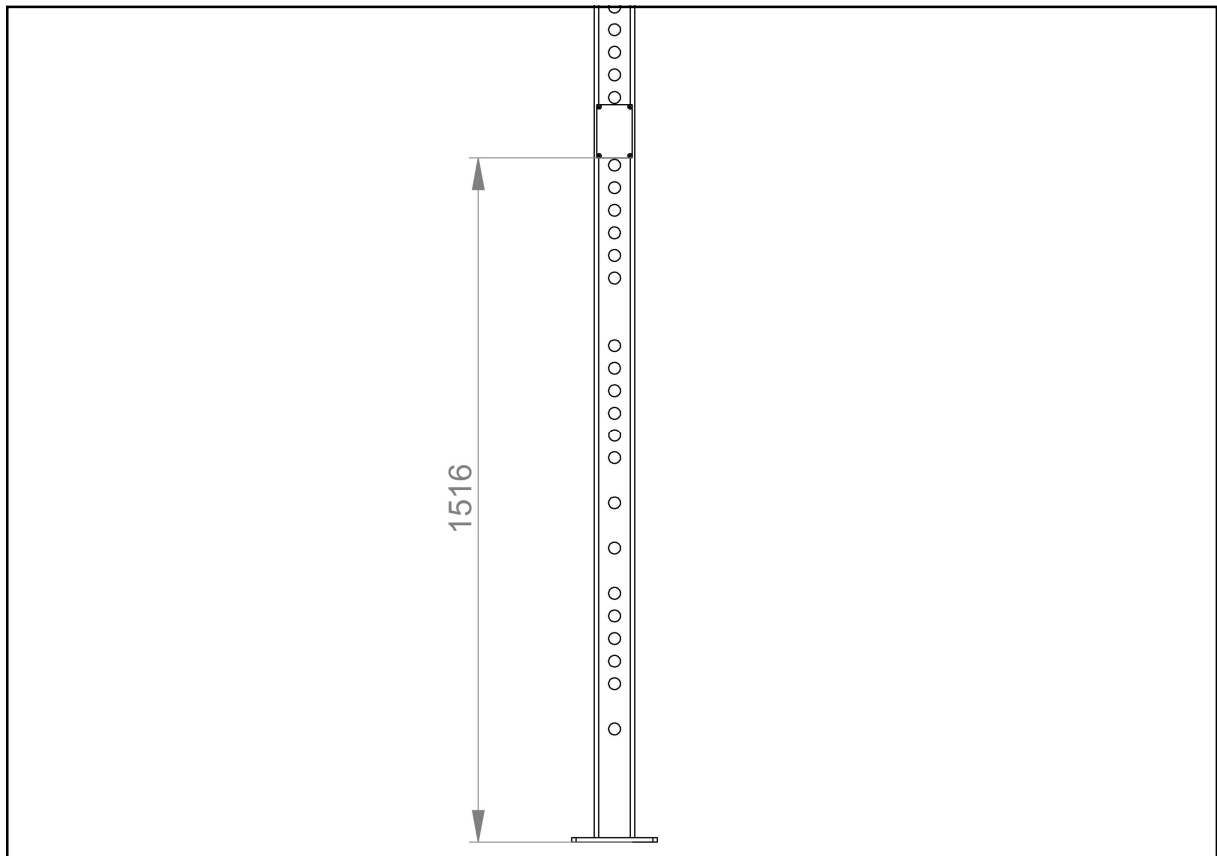
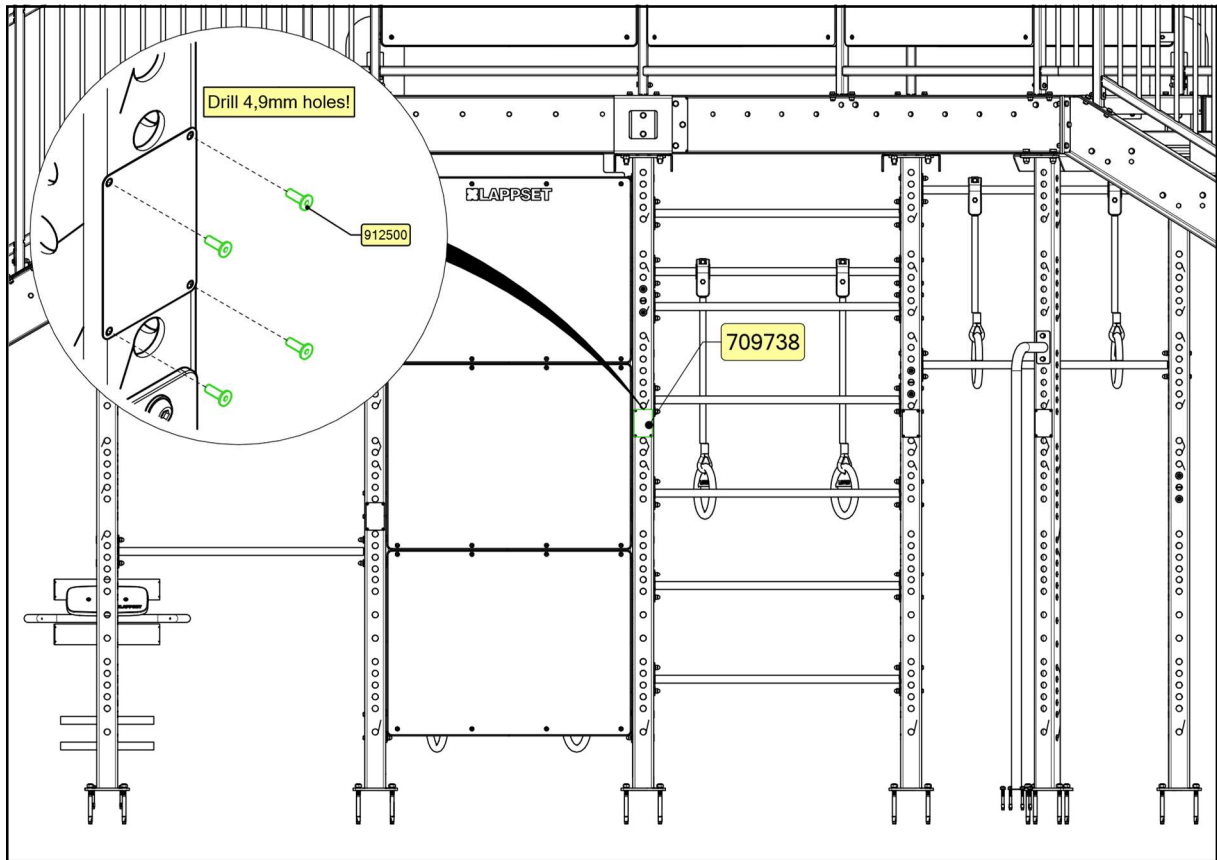

## SISU FITNESS STAIRS

### SIGN 13

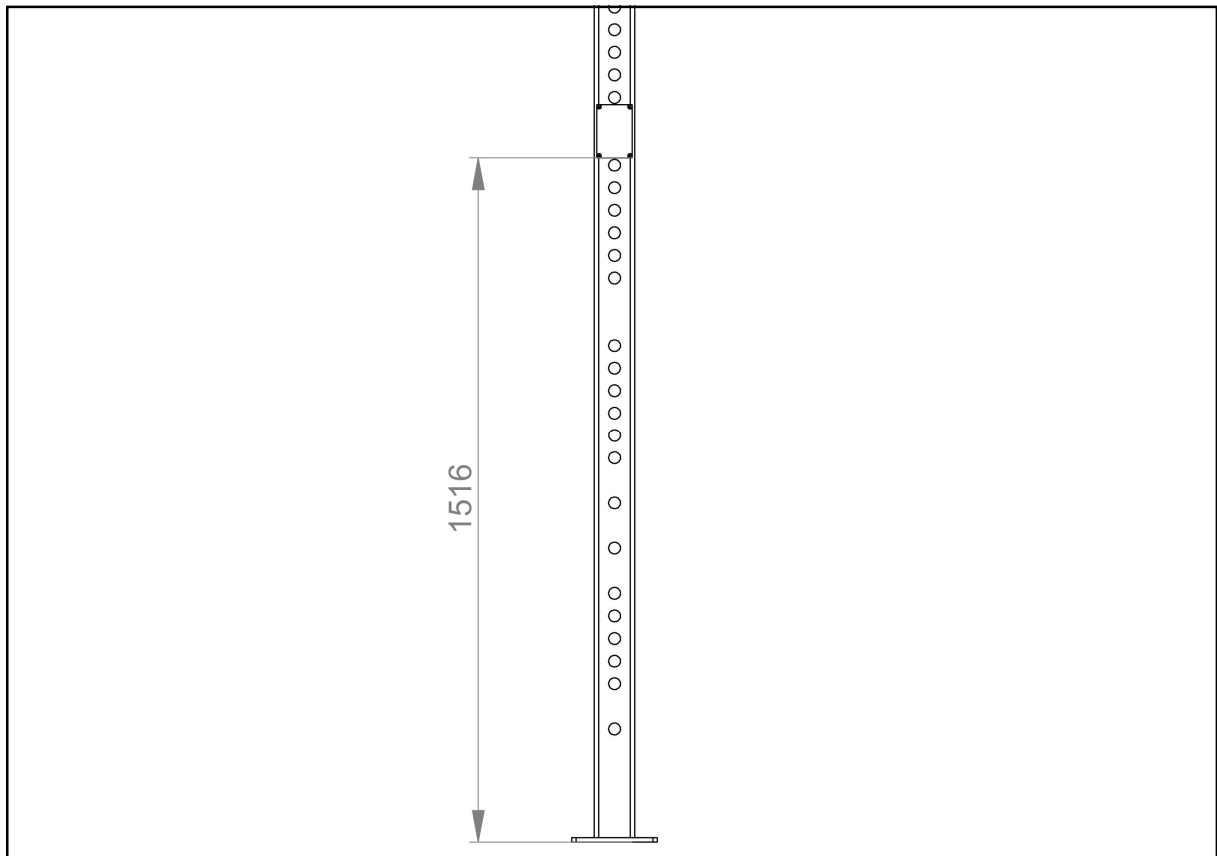
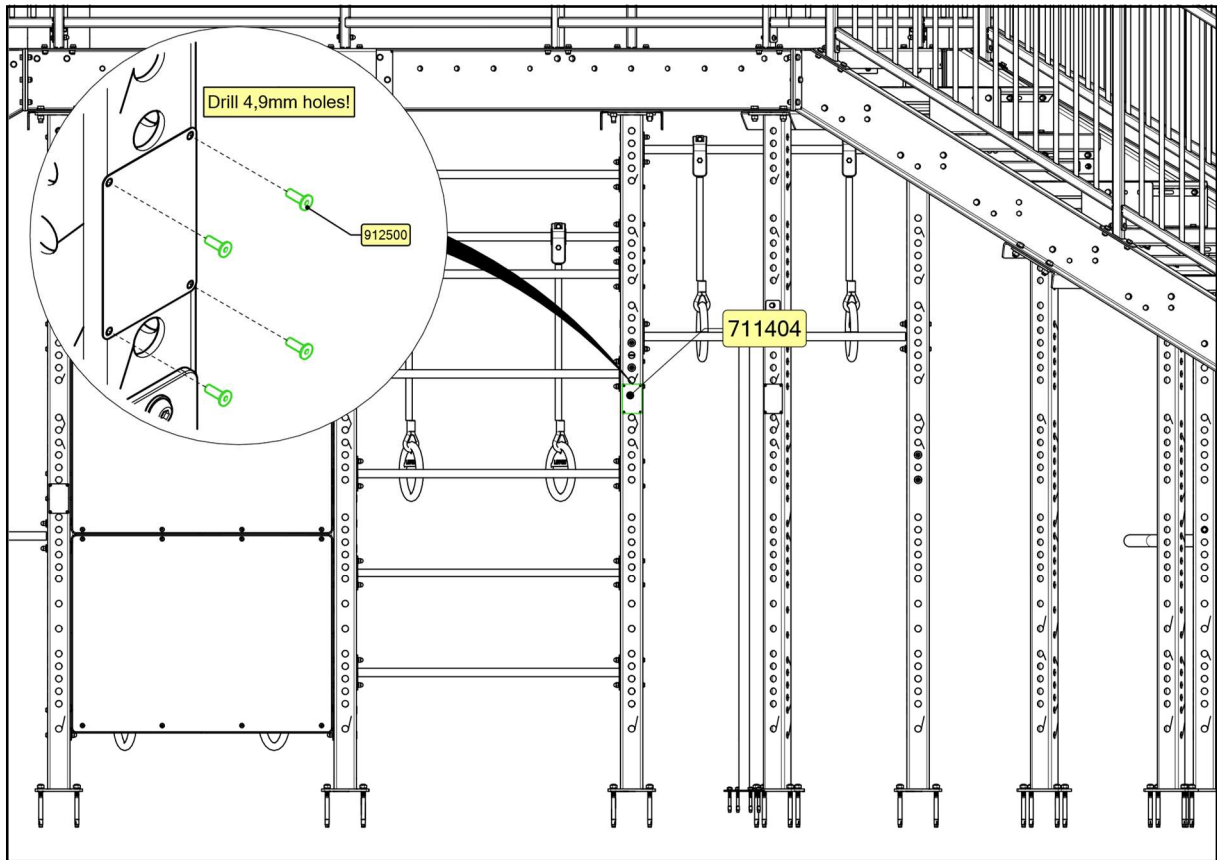

## SISU FITNESS STAIRS

### SIGN 14

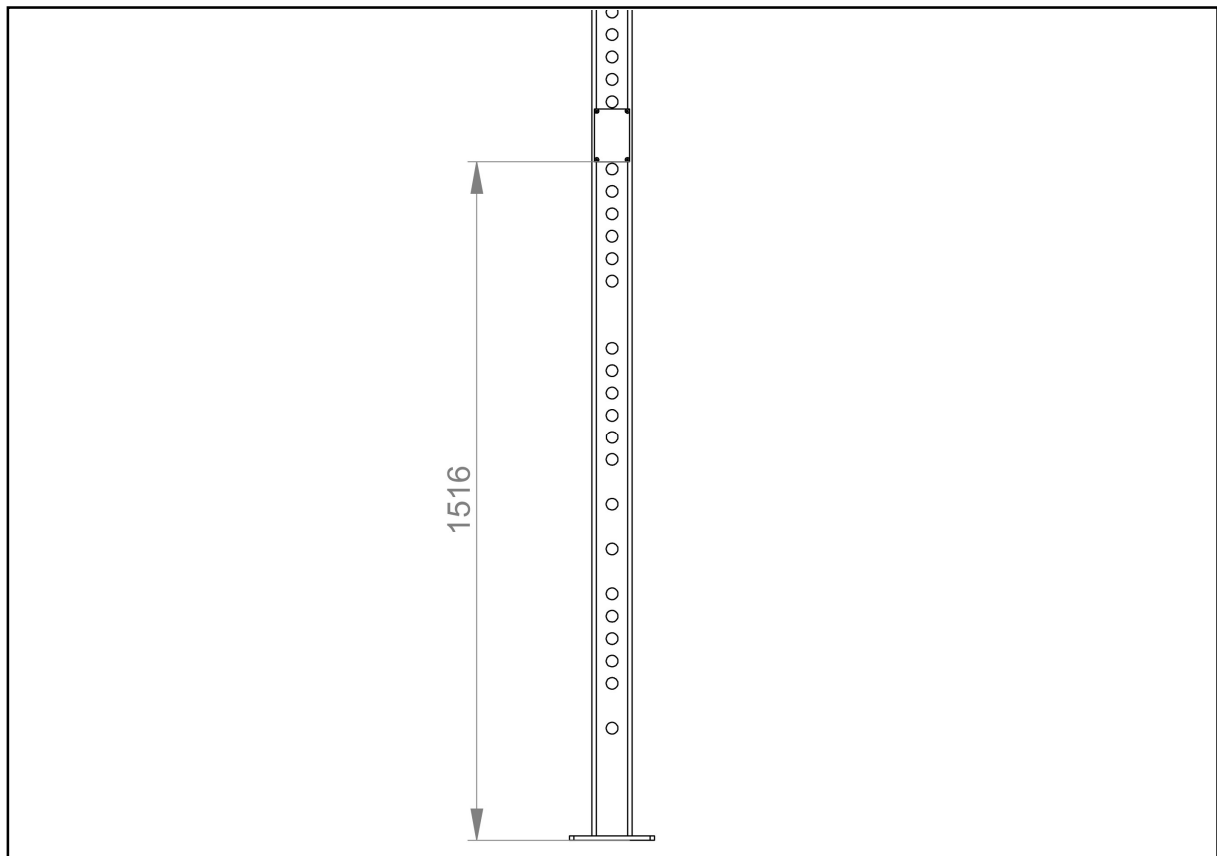
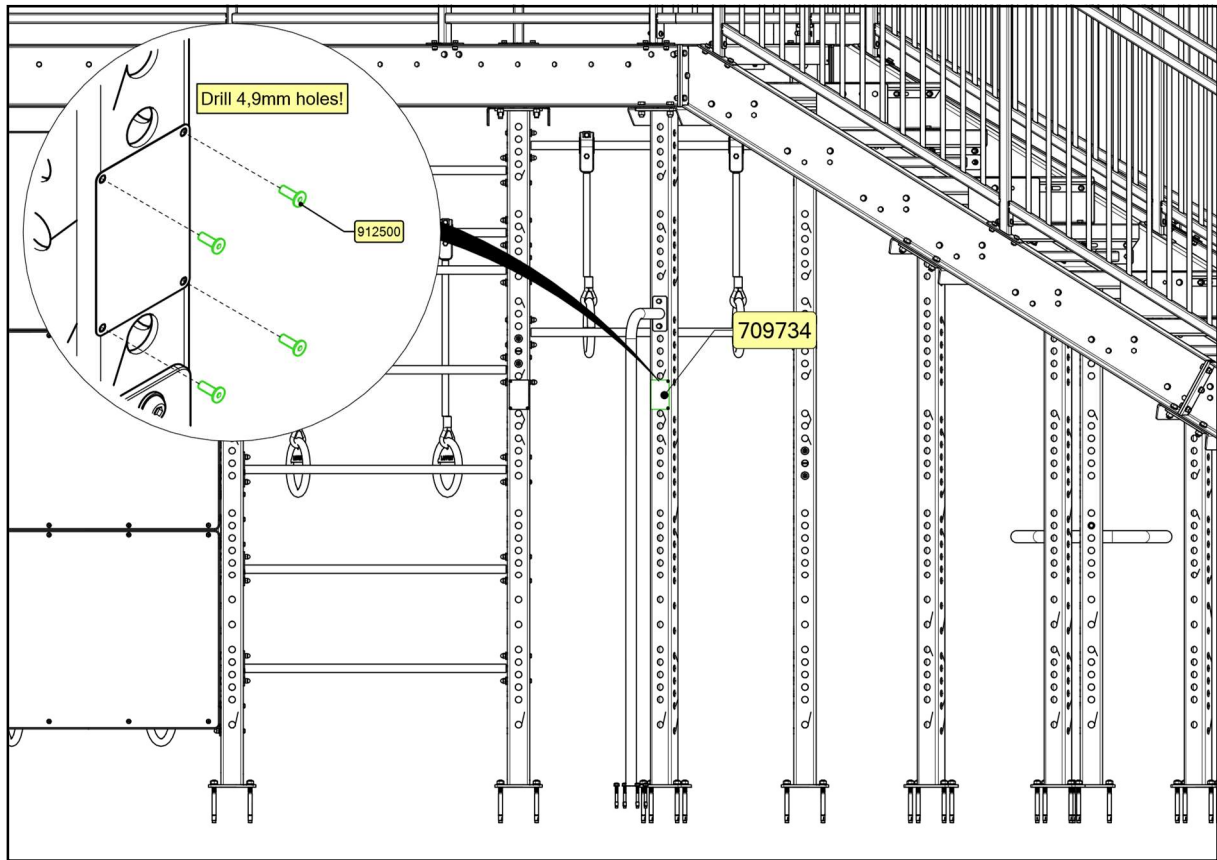

## SISU FITNESS STAIRS

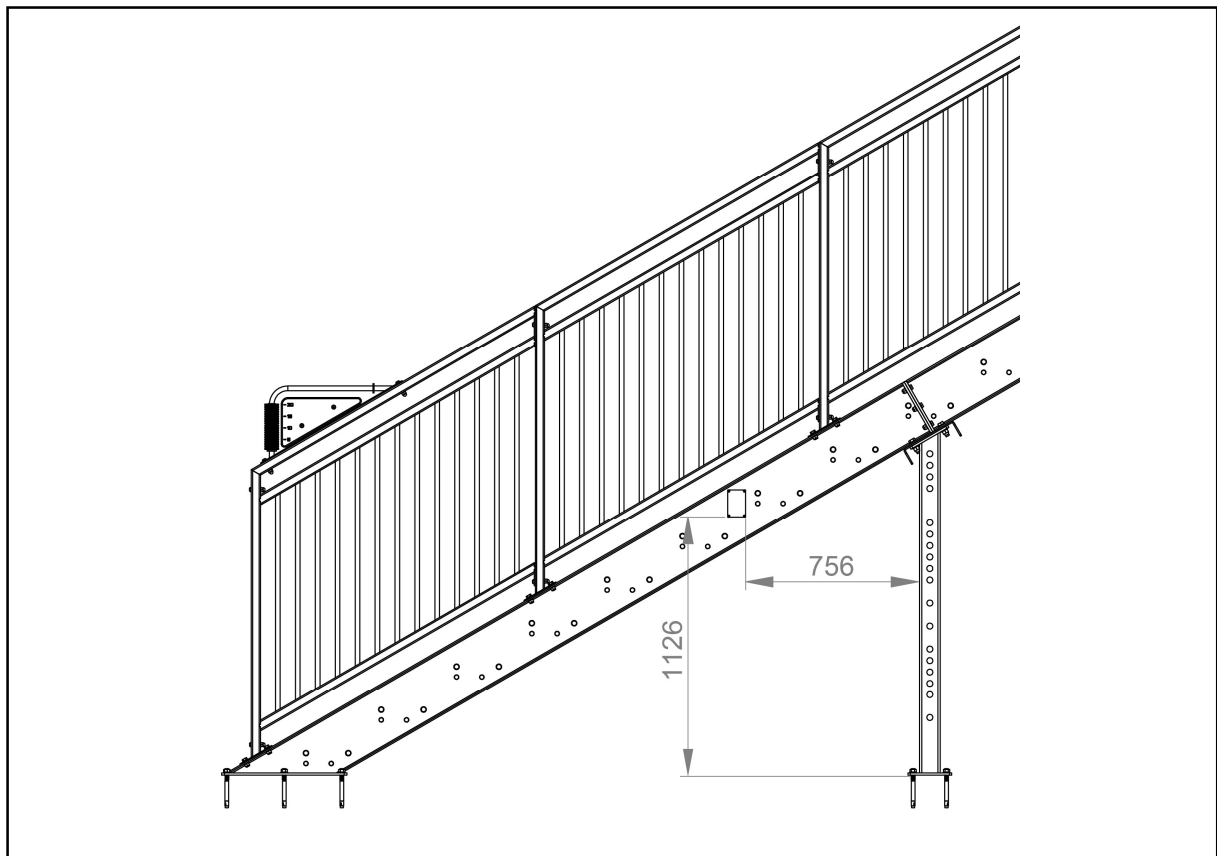
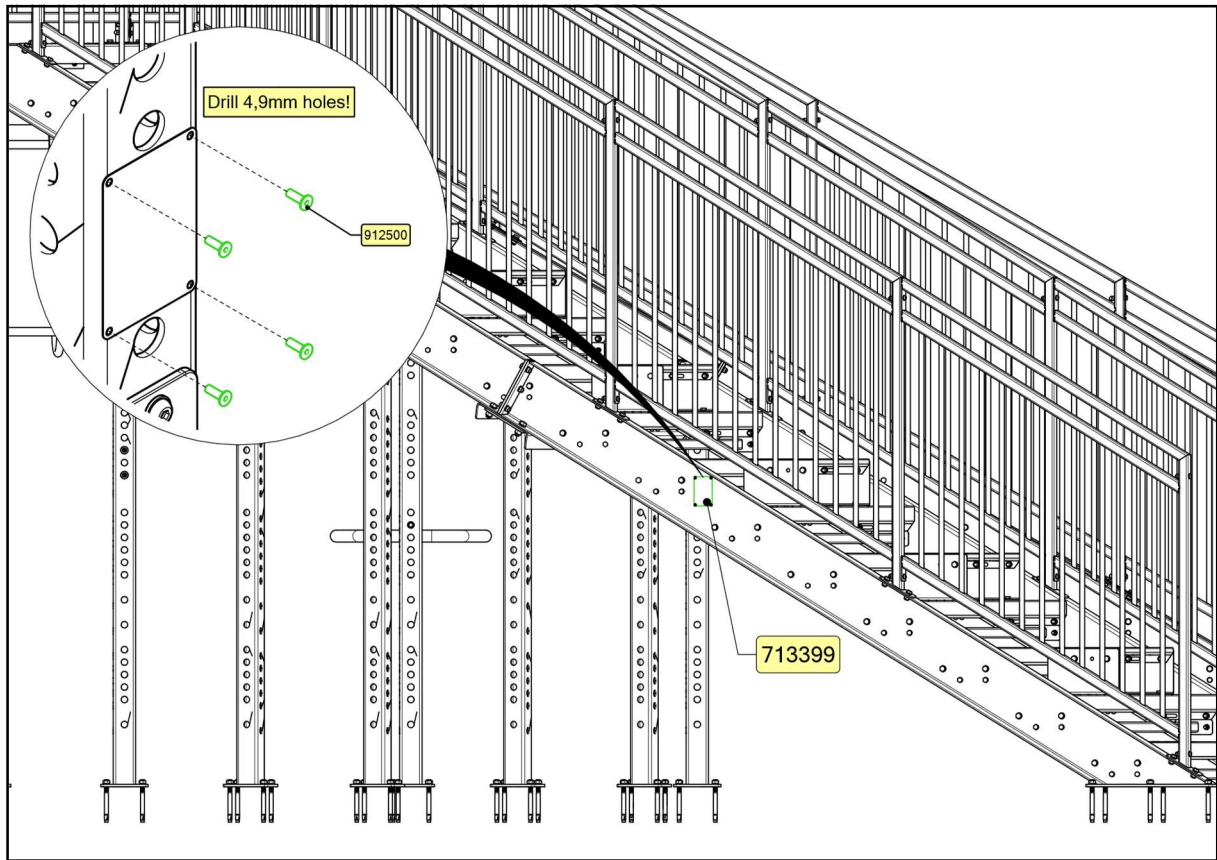

### SIGN 15

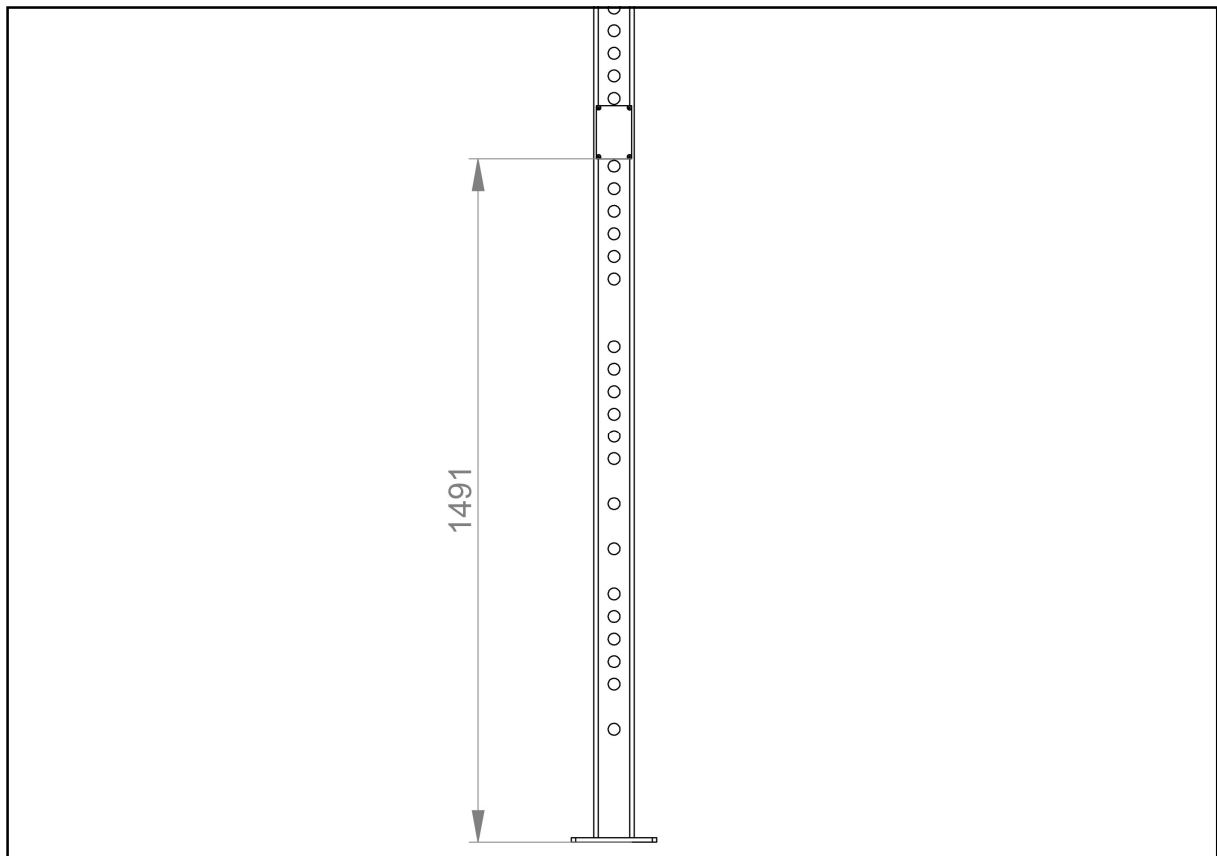
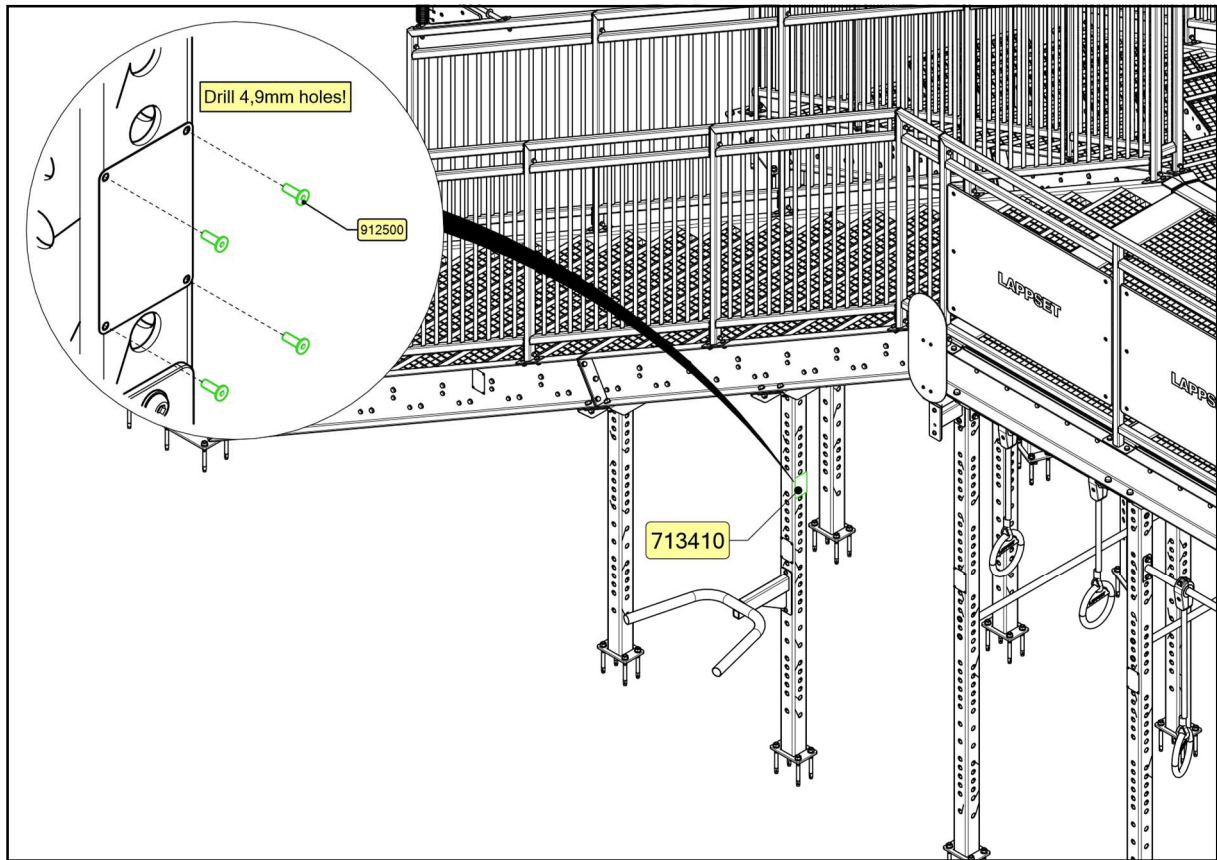

## SISU FITNESS STAIRS

### PRODUCT SIGN

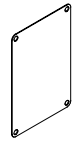

①	SIGN	PCS	②	905390	PCS
 118x78		1	 Ø4,8x28		4

