

1:135

1:135

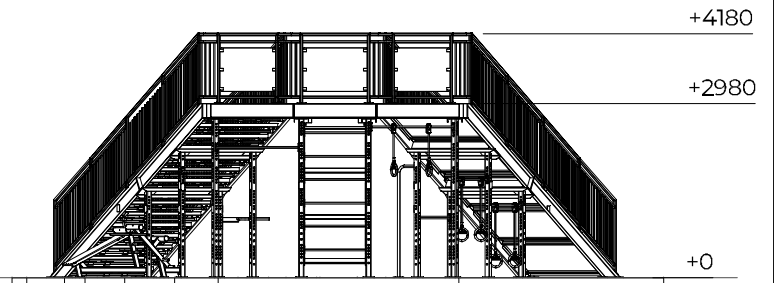

Concrete

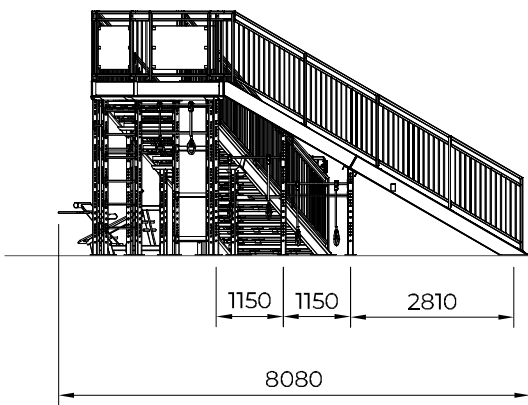
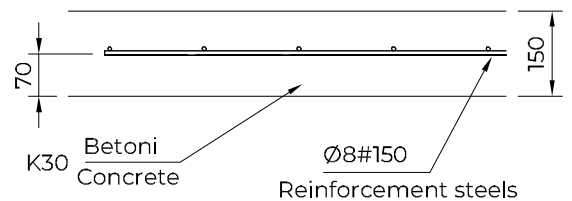

- Area of Movement 87.1 m<sup>2</sup>
- - - Movement Space 96.9 m<sup>2</sup>
- Training Space 20.5 m<sup>2</sup>

Max Falling Height 2980 mm

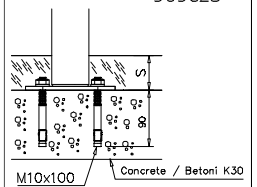
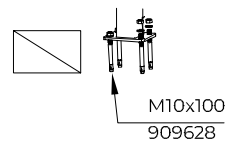
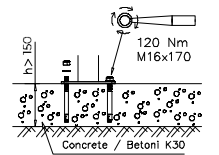
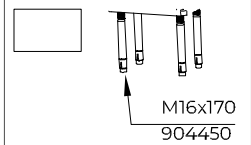
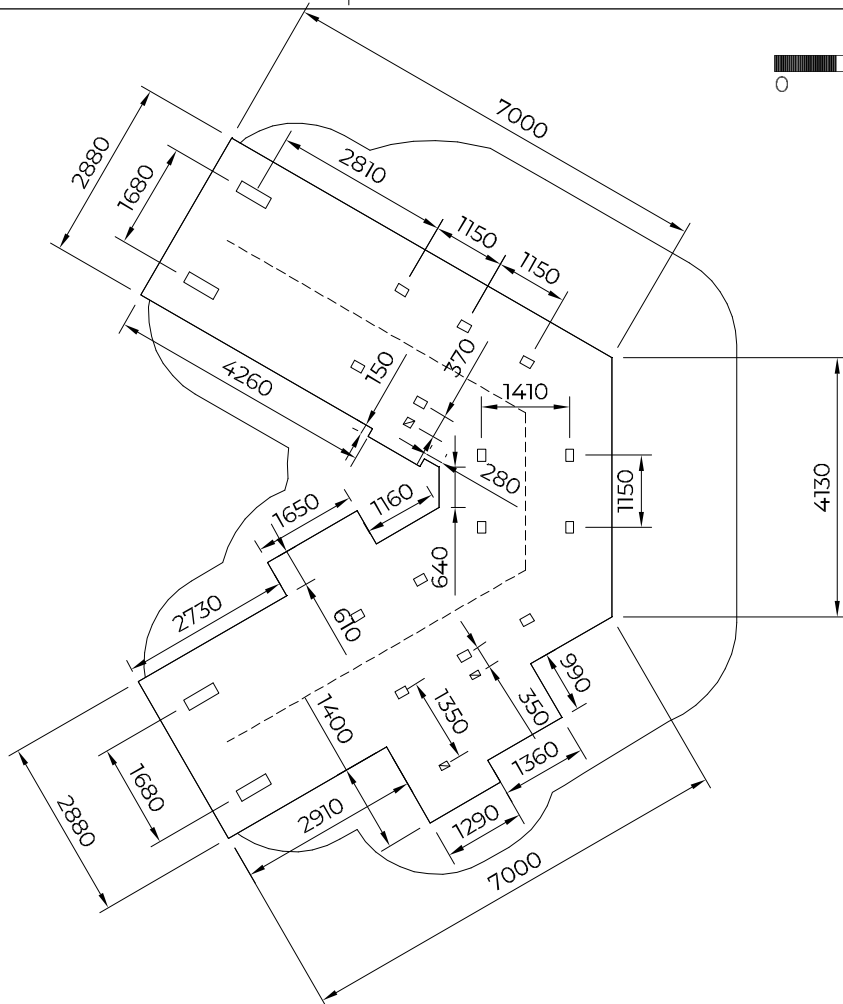
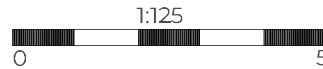
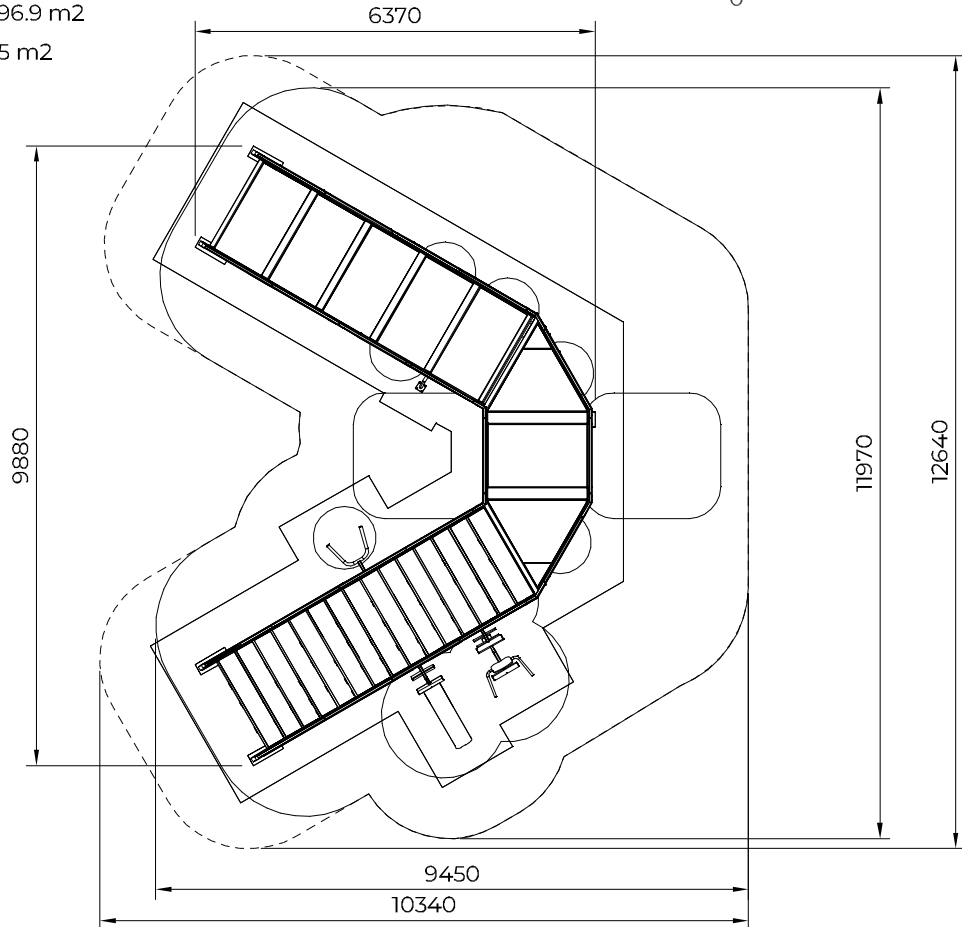

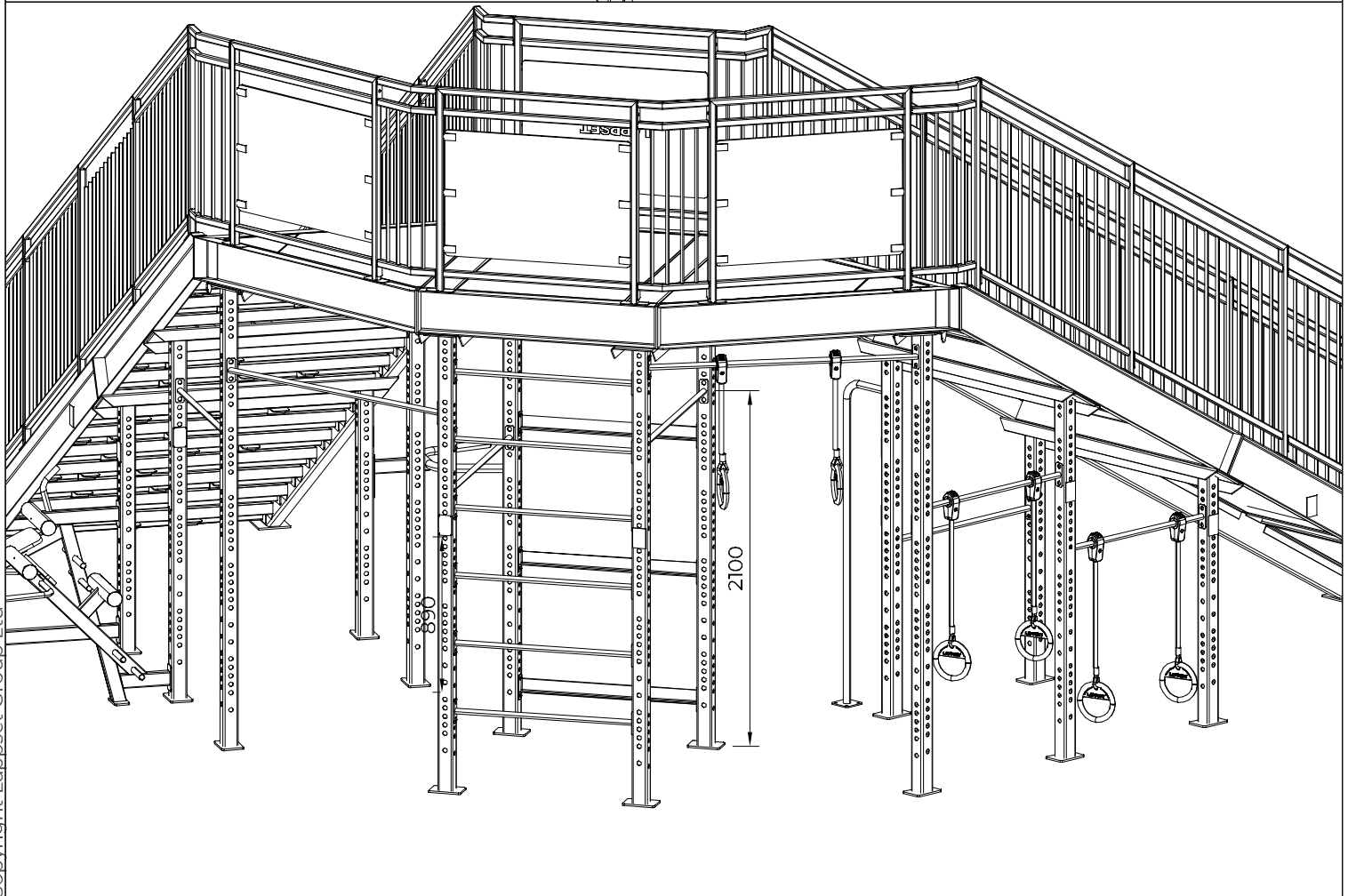
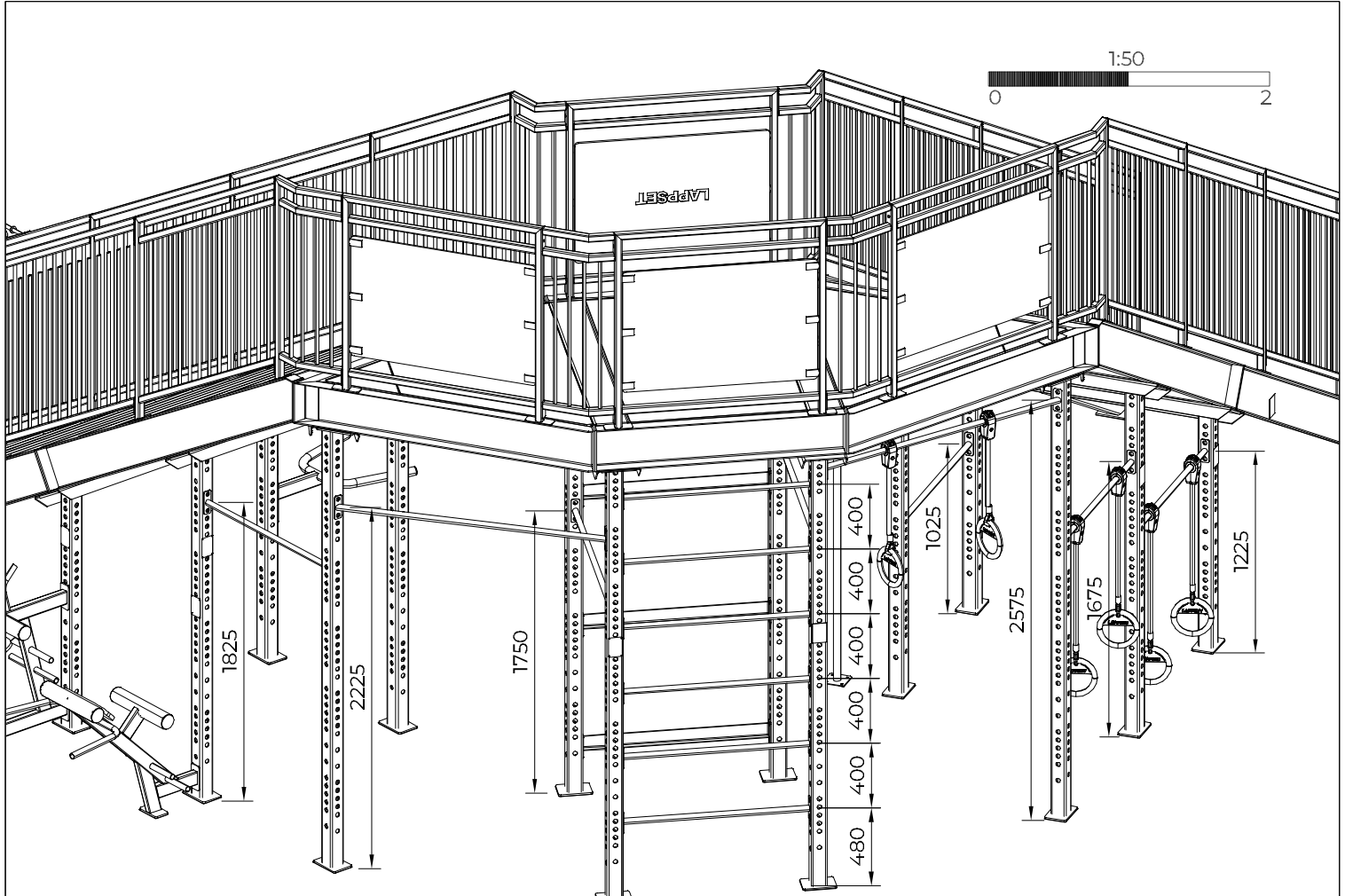

## SISU FITNESS STAIRS

### INSTALLATION MANUAL

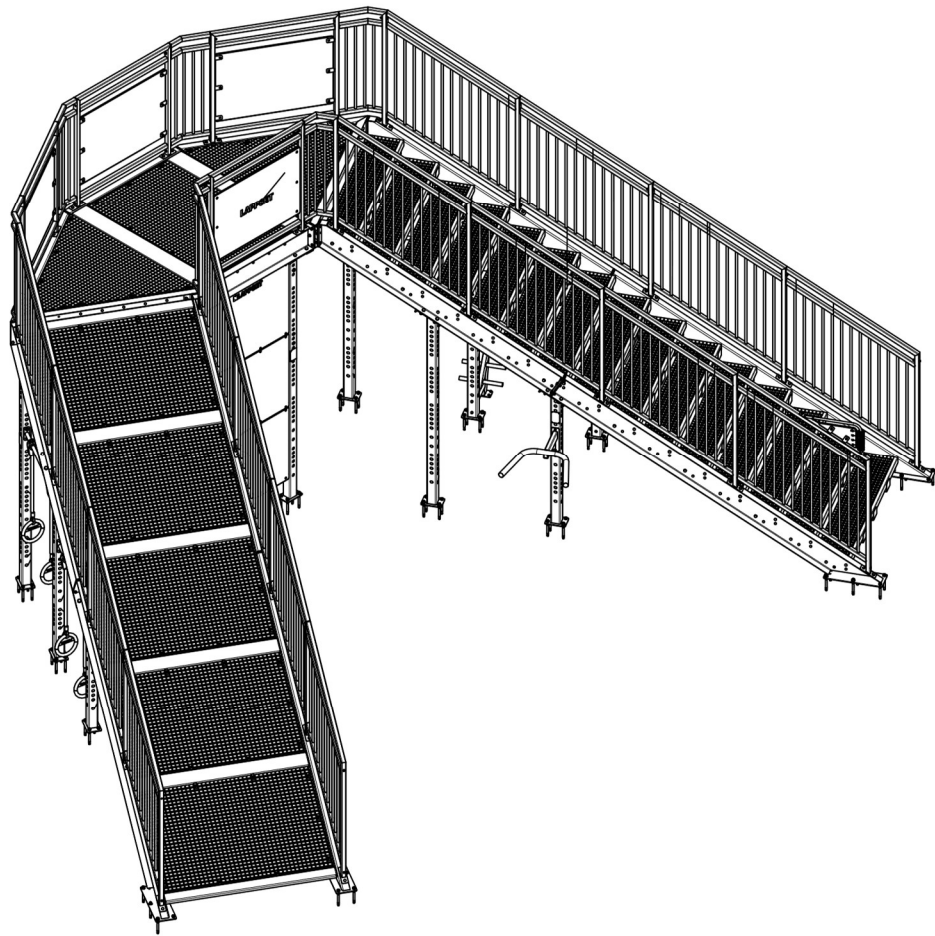

**081878M**

## SISU FITNESS STAIRS

### PART LIST & FASTENING ACCESSORIES

ITEM NO.	PART NUMBER	DESCRIPTION	QTY.
1	709733	SIGN, PULLUP	1
2	709734	SIGN, DRAGON FLAG	1
3	709735	SIGN, GIANT	1
4	709738	SIGN, HANDWALK	1
5	709741	SIGN, RINGSROW	1
6	710040	SIGN, PULLUP	1
7	710483	SIGN, SIT-UP	1
8	710484	SIGN, BACK EXTENSION	1
9	710485	SIGN, DIP	1
10	711404	SIGN, HUMAN FLAG	1
11	712320	LAMINATE	4
12	712439	SEATBOARD	1
13	712464	ROPE ELEMENT	4
14	712467	ROPE ELEMENT	2
15	712494	PLATE	1
16	712495	LAMINATE	2
17	712496	LAMINATE	1
18	713396	SIGN, RING PUSH-UP	1
19	713397	SIGN, RAMP	1
20	713398	SIGN, STAIRS	1
21	713412	PRODUCT SIGN, 081878M	1
22	900965	CAP NUT, M10, DIN 986, nyloc rst	155
23	901302	WASHER, (M10), DIN 125, A2	125
24	902195	CLAMP	12
25	902232	ALLEN SCREW, M10x55, A2 + 2 X DELTA GZ	6
26	902233	ALLEN SCREW, M10x30, A2 + 2 X DELTA GZ	6
27	903148	BOLT, M16 x 50, KS, DIN 931 8,8	56
28	903149	BOLT, M12 x 30, KS, DIN 931 5,8	148
29	903158	LOCK NUT, M16, DIN 985, nyloc zn	56
30	904450	ANCHOR, M16x170	80
31	905827	ALLEN SCREW, M8 x 20	180
32	906006	SLEEVE	12
33	906598	STICKER	1
34	909248	LOCK NUT, M12, DIN 985, nyloc zn	184
35	909256	WASHER, (M8), DIN 125, A2	360
36	909349	BOLT, M12 x 40, KS, DIN 601 4,6	36
37	909520	WASHER, (M16), DIN 125, A2	112
38	909628	ANCHOR, M10x100	12
39	909629	BOLT, M10 x 30, KS, DIN 933 8,8	152
40	909633	CAP NUT, M8, DIN 986, A2, nyloc rst	238
41	909637	LOCK NUT, M10, DIN 985, nyloc zn	153
42	909638	WASHER, (M10), DIN 125, HDG	389
43	909854	COUNTERSUNK SCREW, M8x50 A4	6
44	910376	BUSHING Ø30x17	154

## SISU FITNESS STAIRS

45	910416	INSIDE PLUG Ø48/43-45x23	2
46	910455	SUPPORT	1
47	910604	SUPPORT PIECE	4
48	911149	ALLEN SCREW, M10 x 110	83
49	911837	METAL FRAME	1
50	911843	METAL FRAME	1
51	912180	SPECIAL SCREW, Ø8 x 60 DELTA	80
52	912500	RIVET Ø4,8x14	52
53	912515	DIP BAR	1
54	912575	COUNTERSUNK SCREW, M8x110 A4	2
55	914574	FRAME ASSEMBLY	1
56	914579	SUPPORT	6
57	914583	FRAME ASSEMBLY	1
58	914584	FRAME ASSEMBLY	1
59	914585	FRAME ASSEMBLY	1
60	914588	POST	4
61	914590	POST	4
62	914595	POST	4
63	914596	SUPPORT	4
64	914597	SUPPORT	2
65	914598	SUPPORT	12
66	914635	FRAME ASSEMBLY	1
67	914636	FRAME ASSEMBLY	1
68	914637	FRAME ASSEMBLY	1
69	914638	FRAME ASSEMBLY	1
70	914720	HANDRAIL	16
71	914735	GRID	6
72	914746	BAR ELEMENT	2
73	914747	BAR ELEMENT	10
74	914751	TUBE ASSEMBLY	15
75	914753	BRACKET	45
76	914777	STEP	15
77	914819	FASTENER	80
78	914885	ALLEN SCREW, M10 x 60	58
79	914904	COUNTERSUNK SCREW, M8x25 A2	50
80	915360	COVER	4
81	915361	COVER	1
82	915409	SUPPORT	2
83	915416	COUNTER	1
84	915548	FRAME ASSEMBLY	2
85	915550	HANDRAIL	4
86	915552	FRAME ASSEMBLY	1
87	915553	GRID	2
88	915572	FRAME ASSEMBLY	1
89	915573	SUPPORT	4
90	915574	SUPPORT	2
91	915577	POST	1

**SISU FITNESS STAIRS**

92	915581	POST	1
93	915584	HANDRAIL	1
94	915591	HANDRAIL	1
95	915592	HANDRAIL	1
96	915596	HANDRAIL	1
97	915598	HANDRAIL	1
98	915605	HANDRAIL	1
99	915609	GRID	2
100	915610	BAR ELEMENT	2
101	980151	WASHER, (M8), DIN 125, HDG	58
102	980154	WASHER, (M12), DIN 125, HDG	368
103	914838-213	SIGN, YELLOW	15
104	914838-241	SIGN, BLUE	15
105	914838-260	SIGN, RED	15

## SISU FITNESS STAIRS

### STAIRS (1 PC)

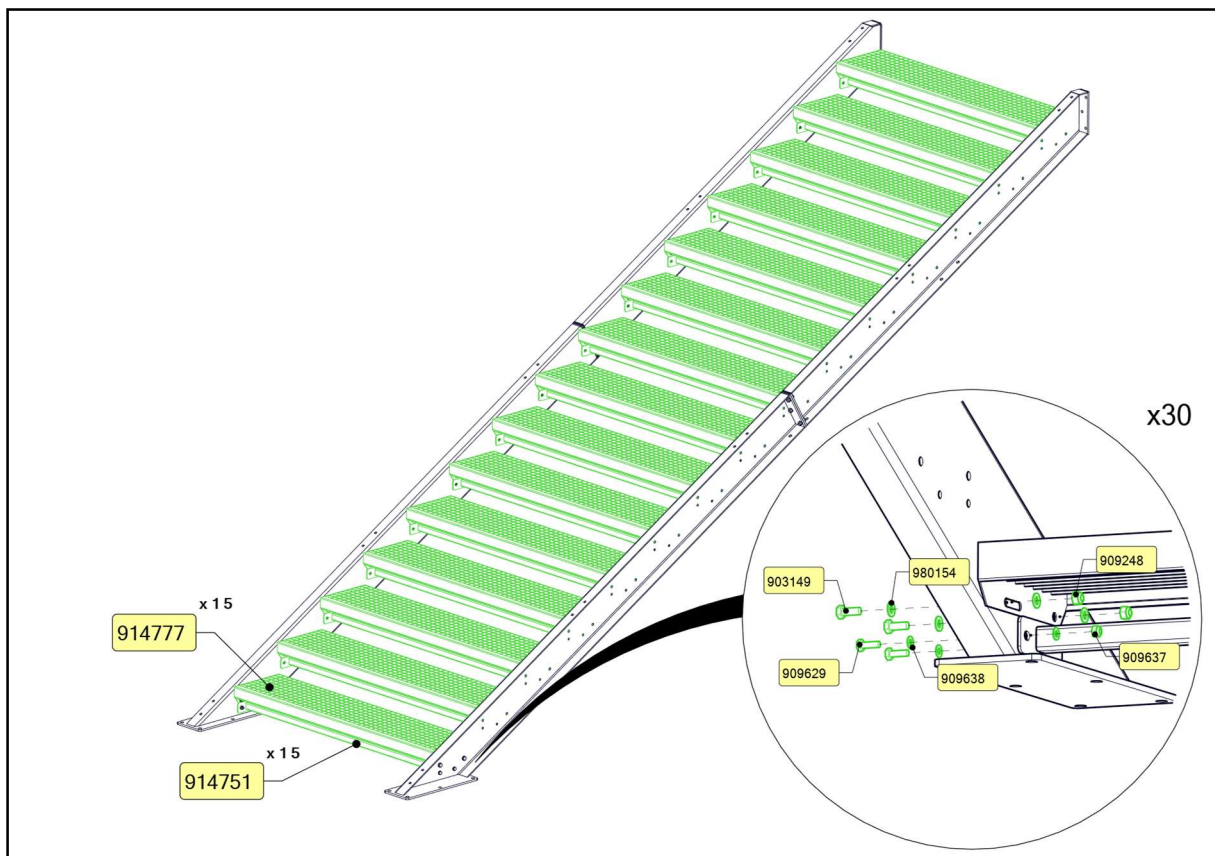
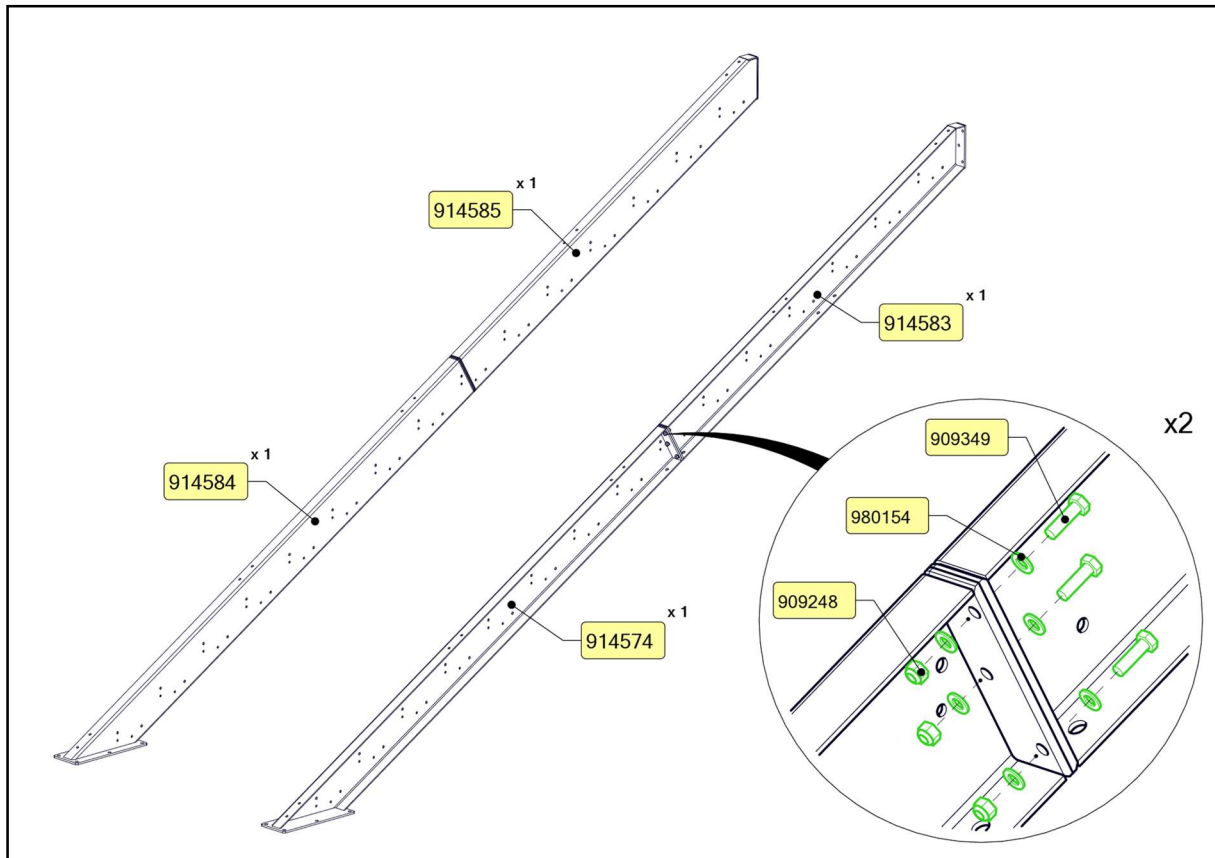

## SISU FITNESS STAIRS

### STAIRS (1 PC)

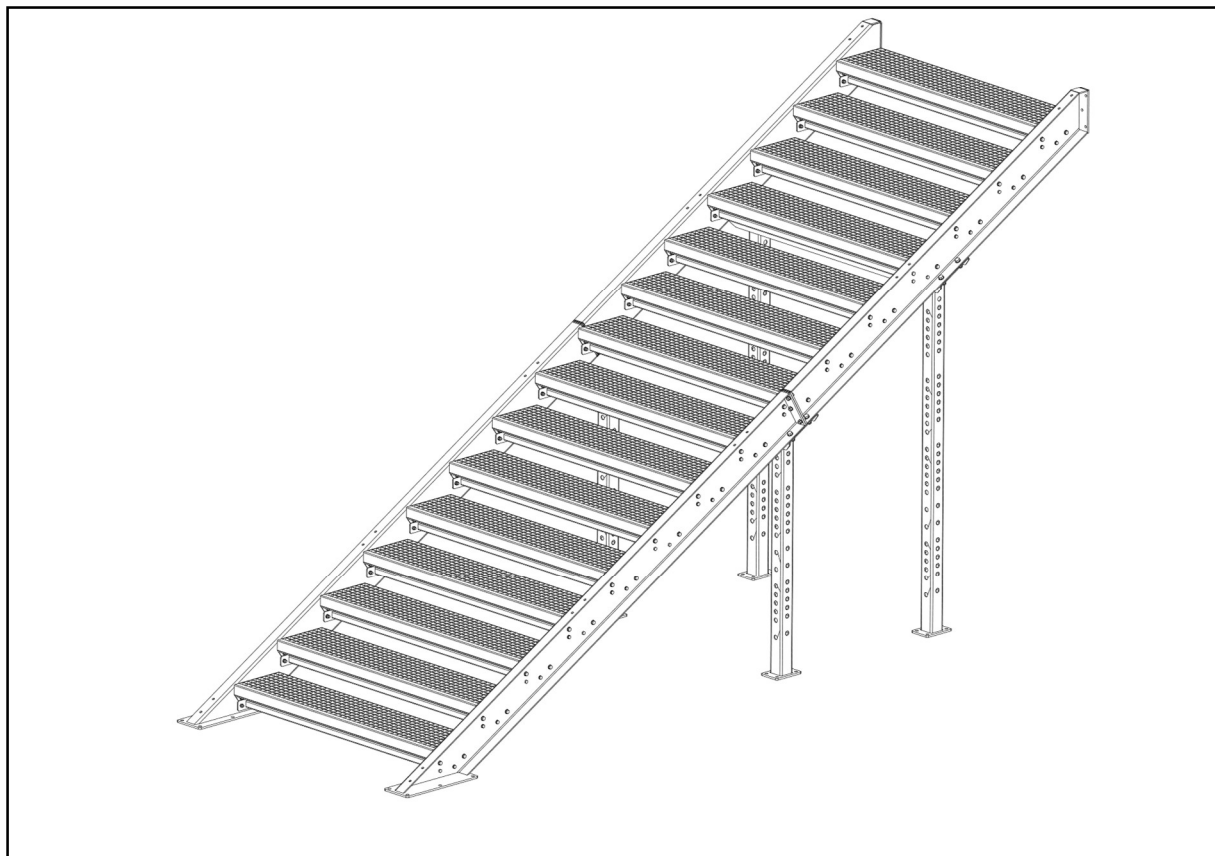
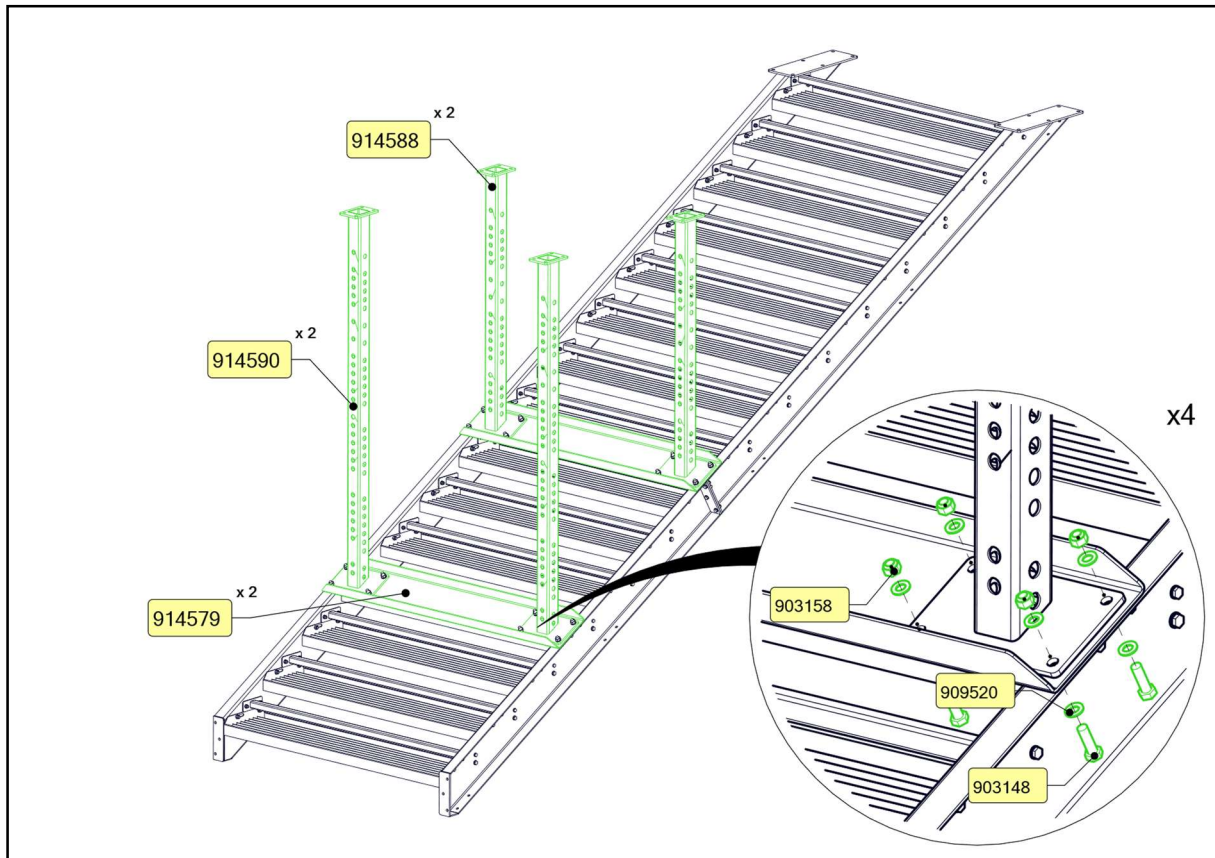

## SISU FITNESS STAIRS

### RAMP (1 PC)

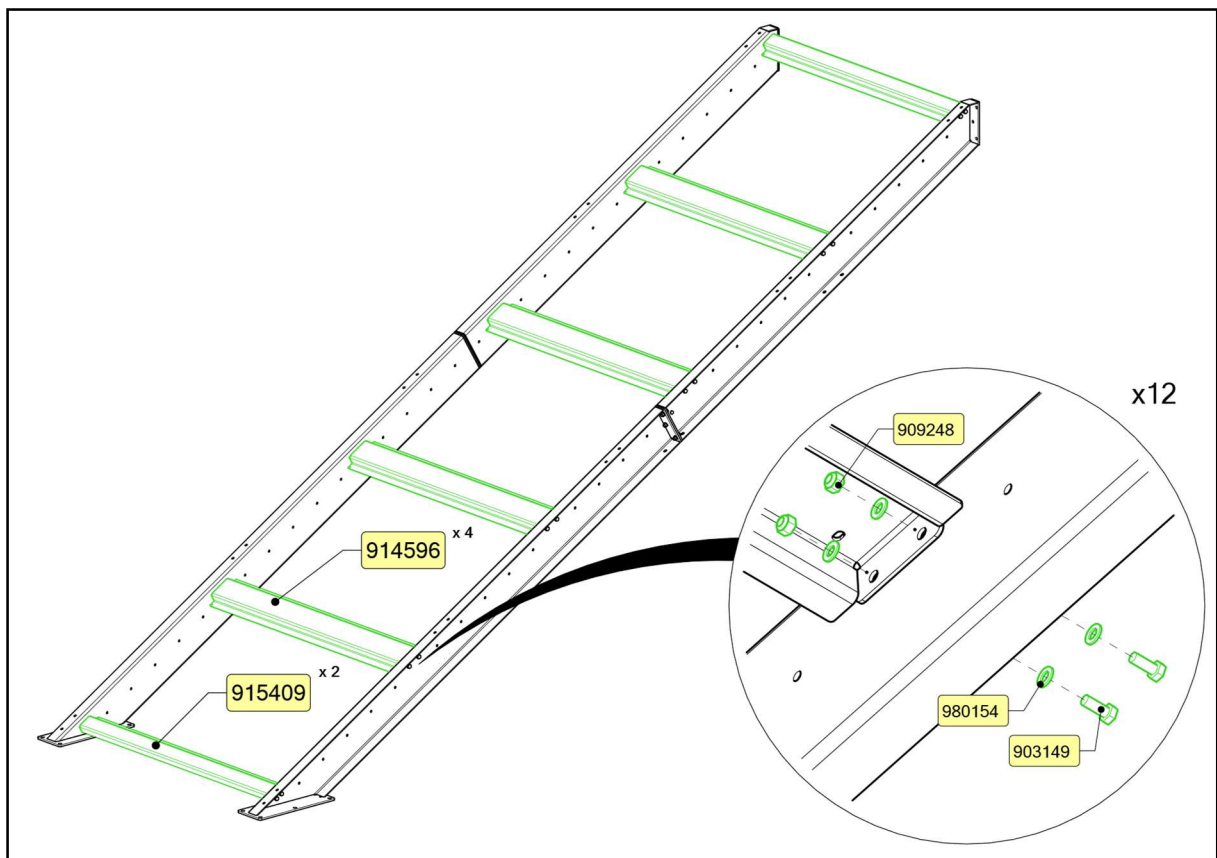
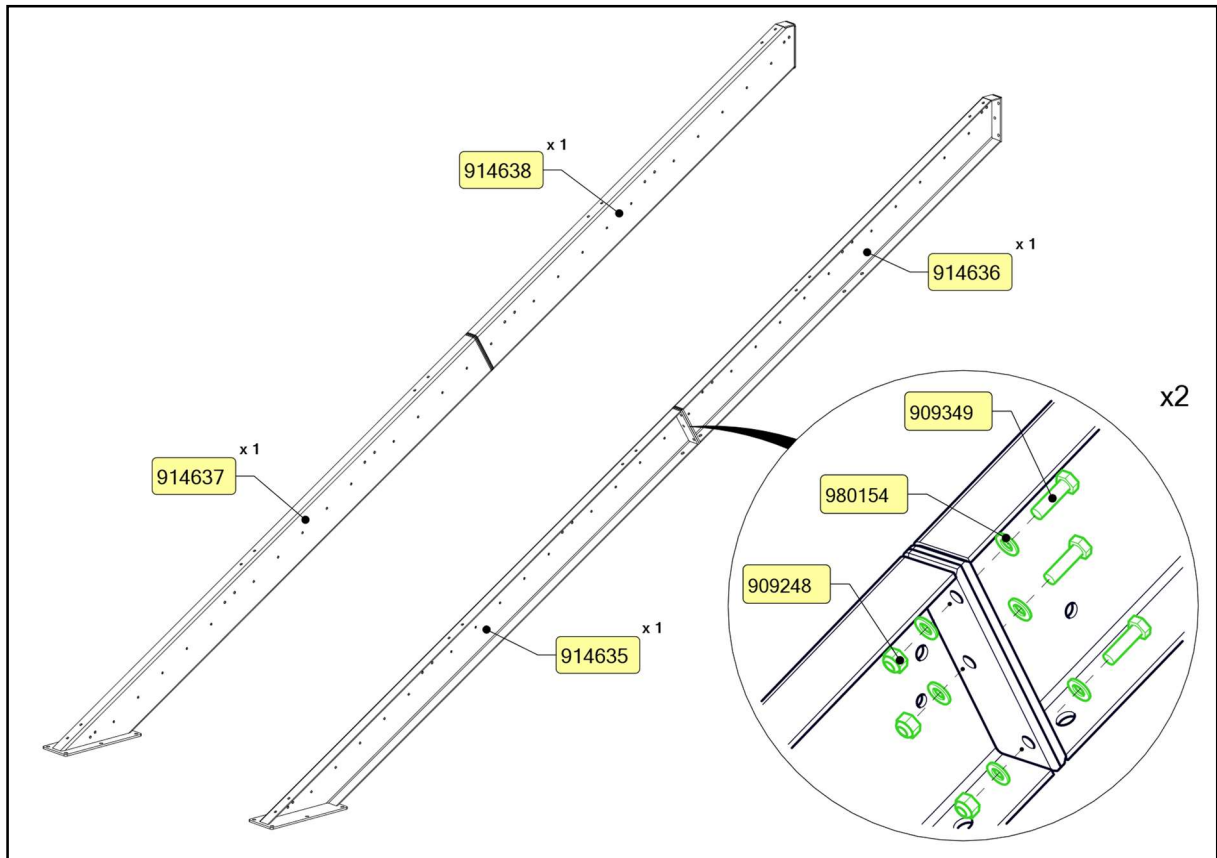

## SISU FITNESS STAIRS

### RAMP (1 PC)

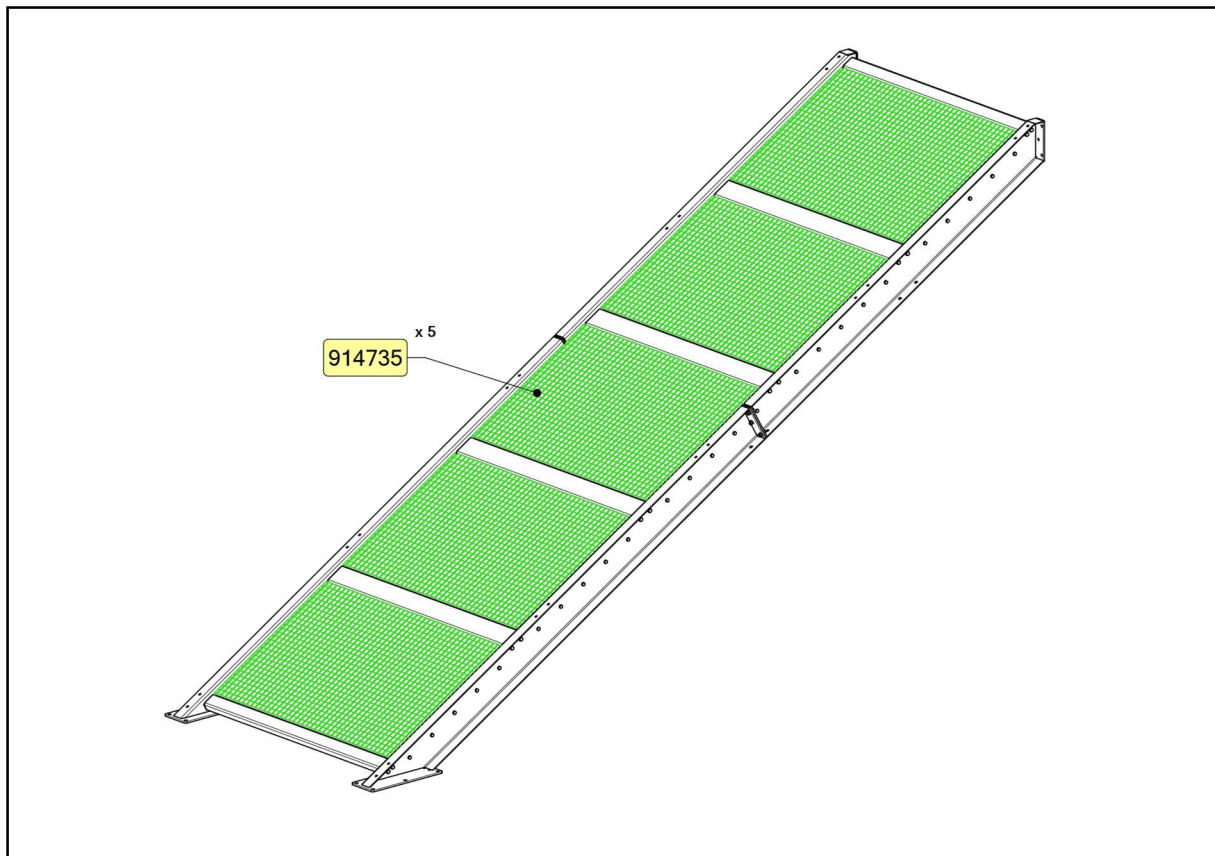
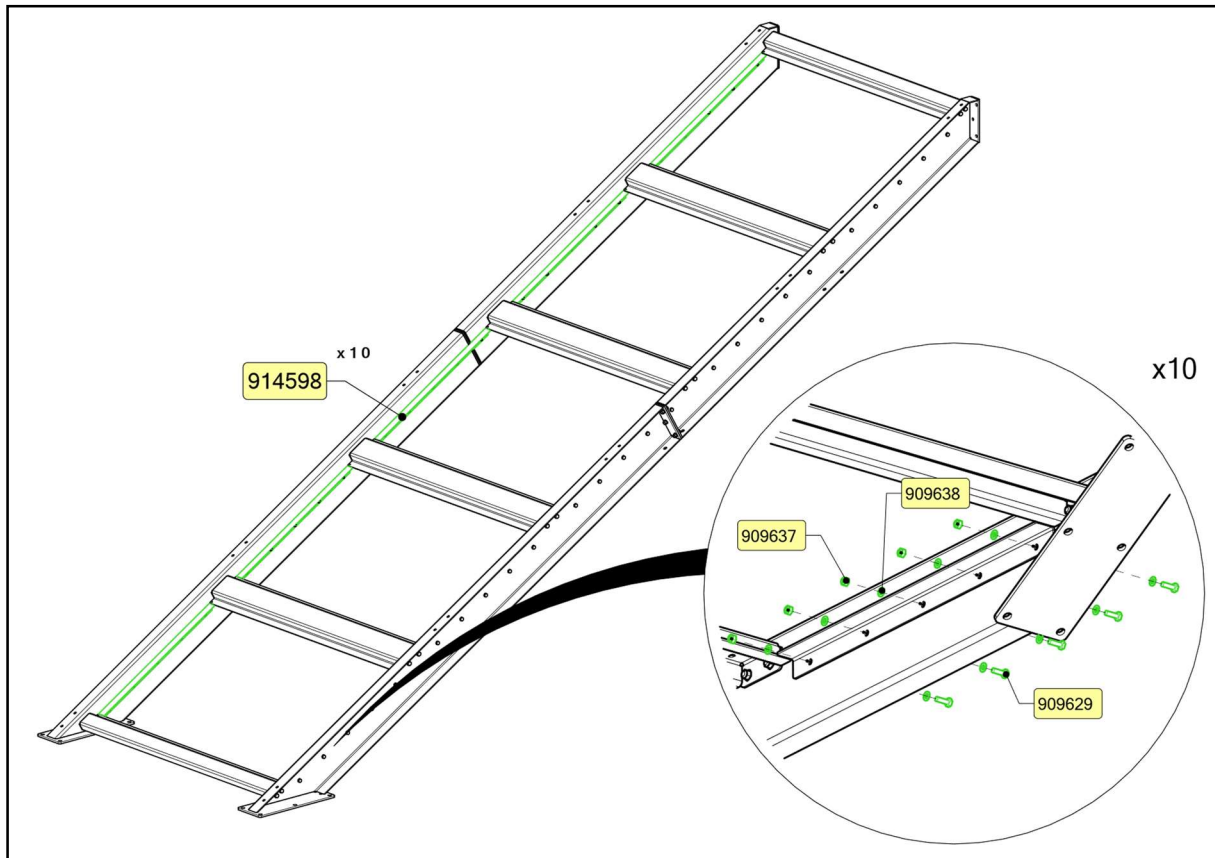

## SISU FITNESS STAIRS

### RAMP (1 PC)

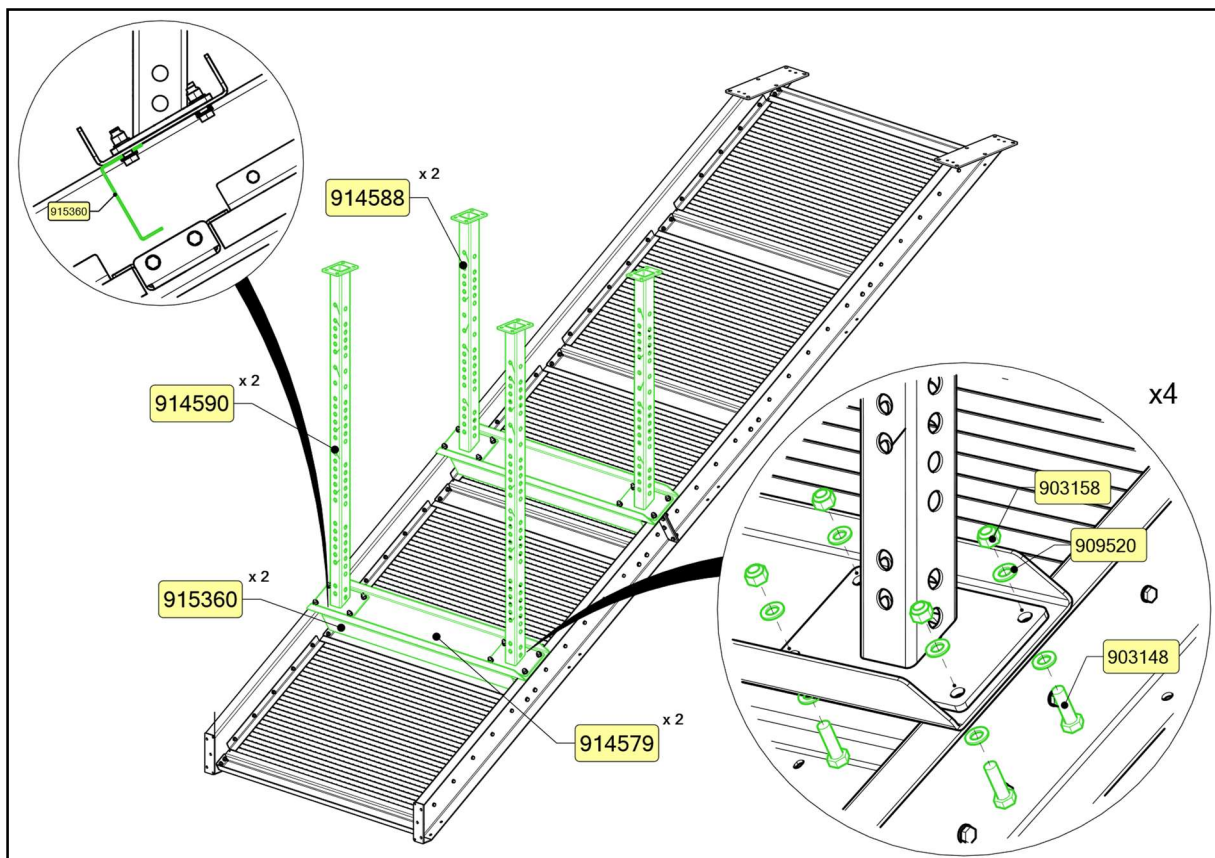
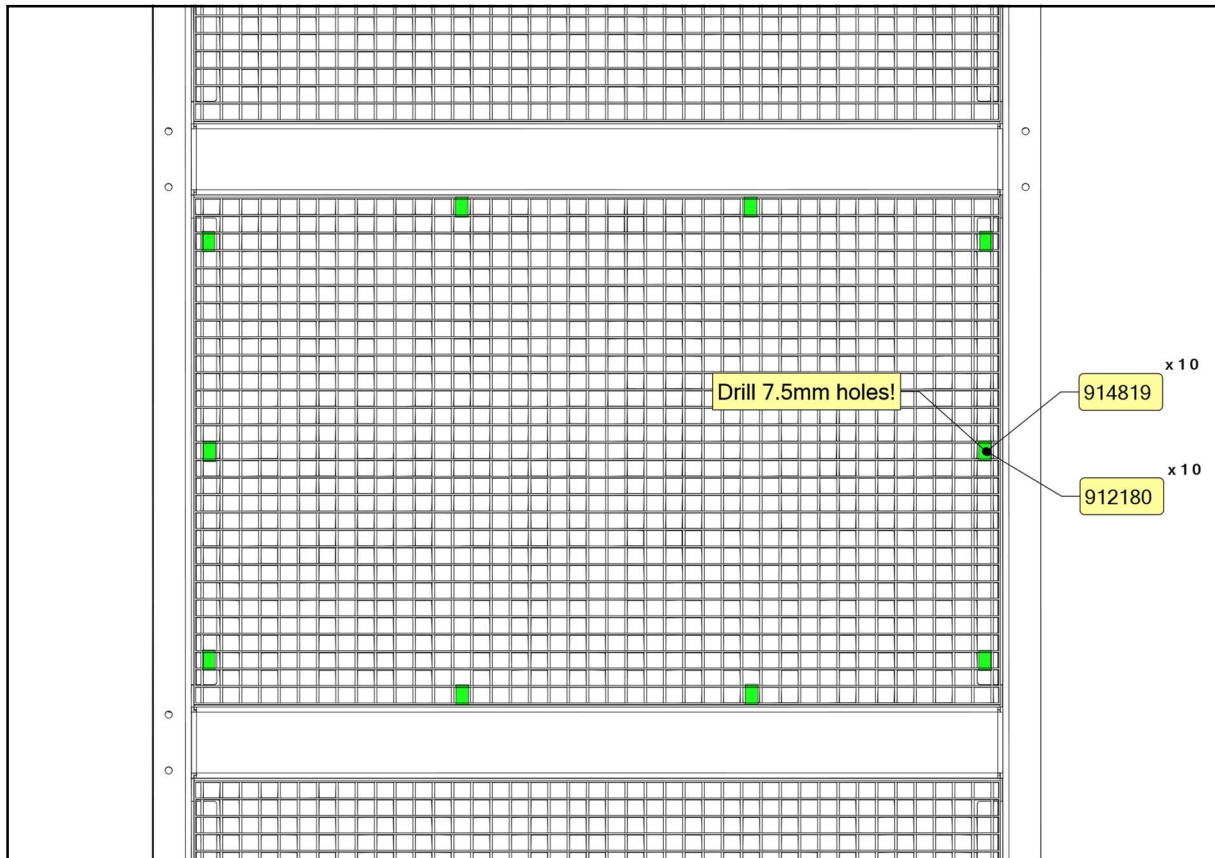

## SISU FITNESS STAIRS

### RAMP (1 PC)

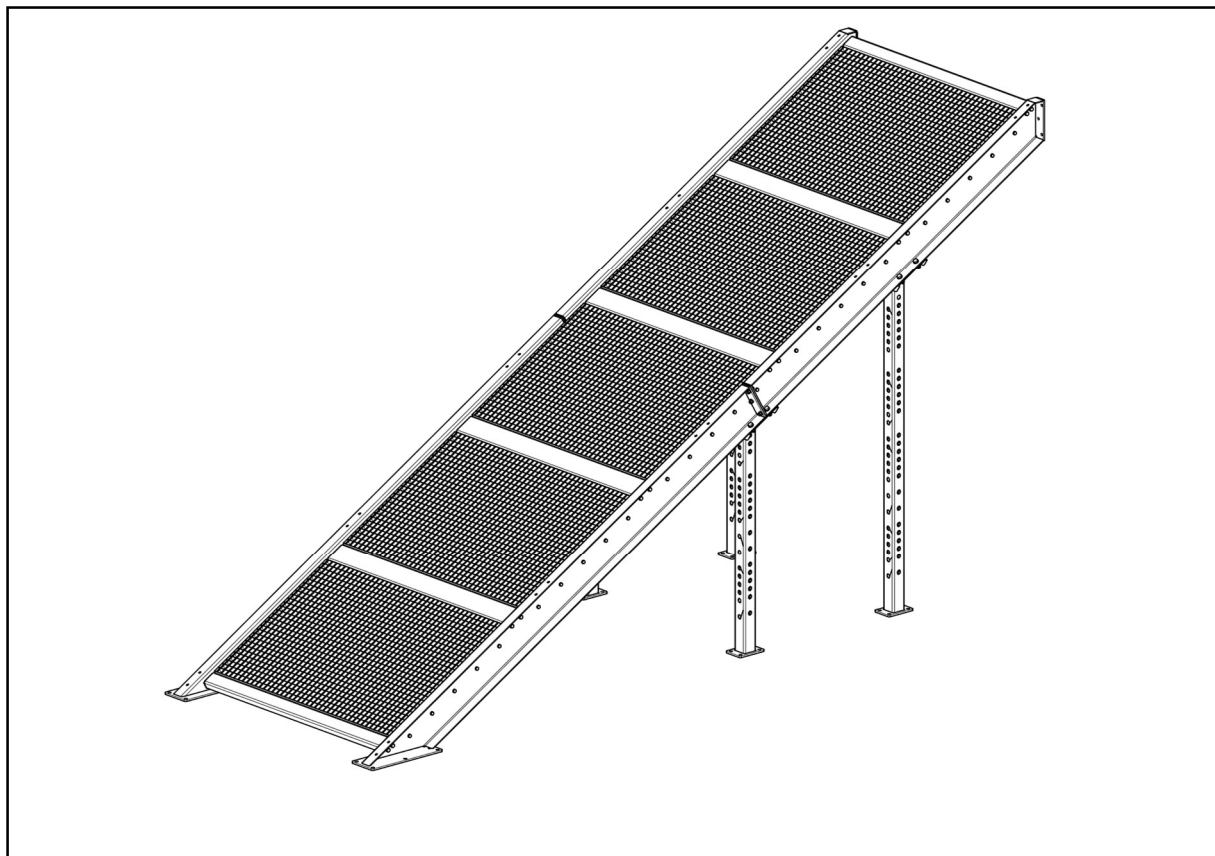
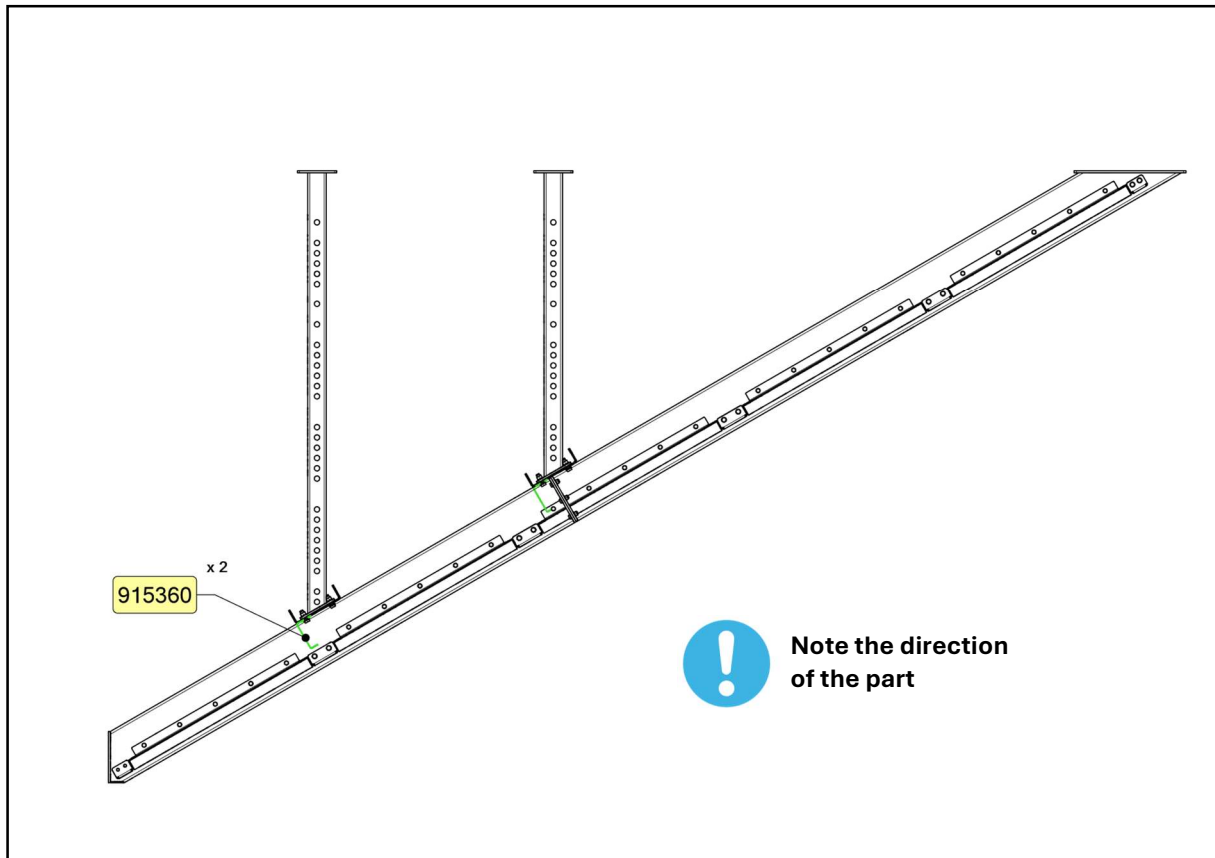

## SISU FITNESS STAIRS

### FLOOR-1 (1 PC)

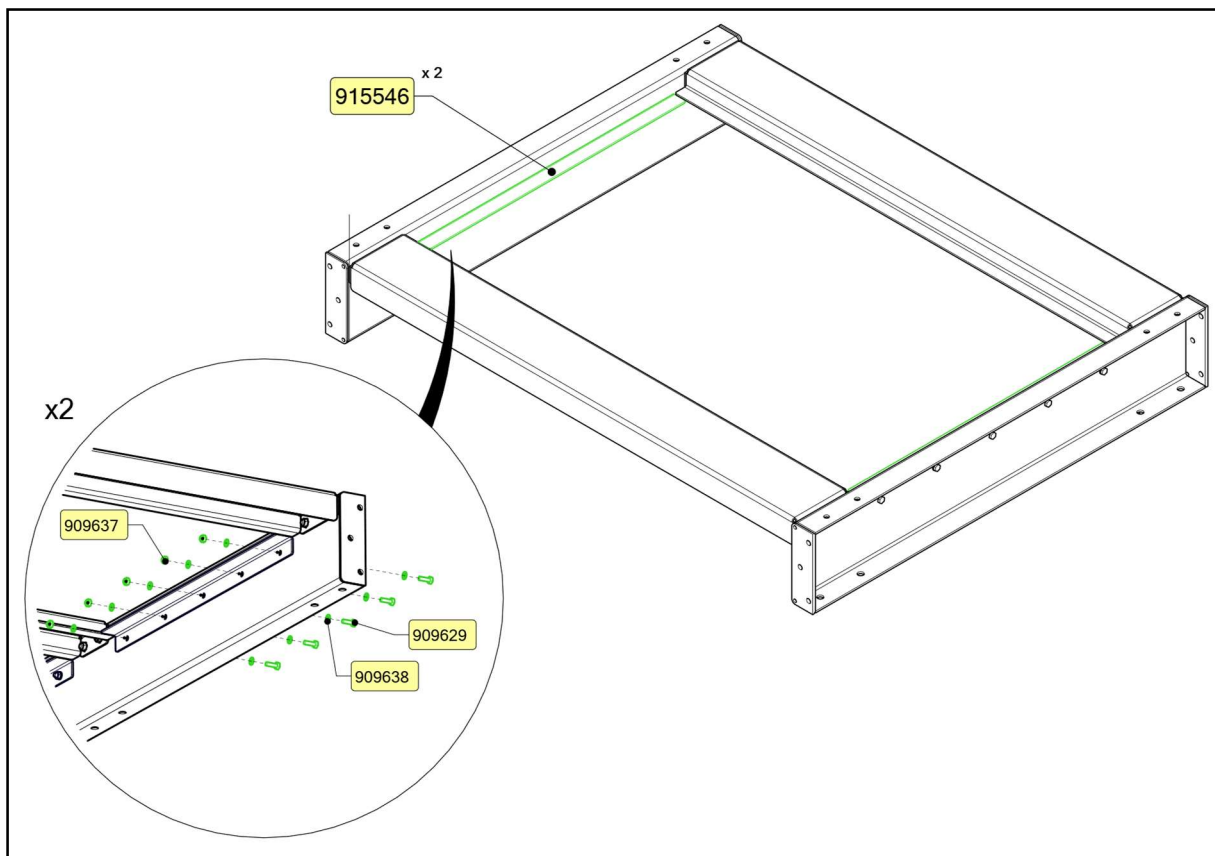
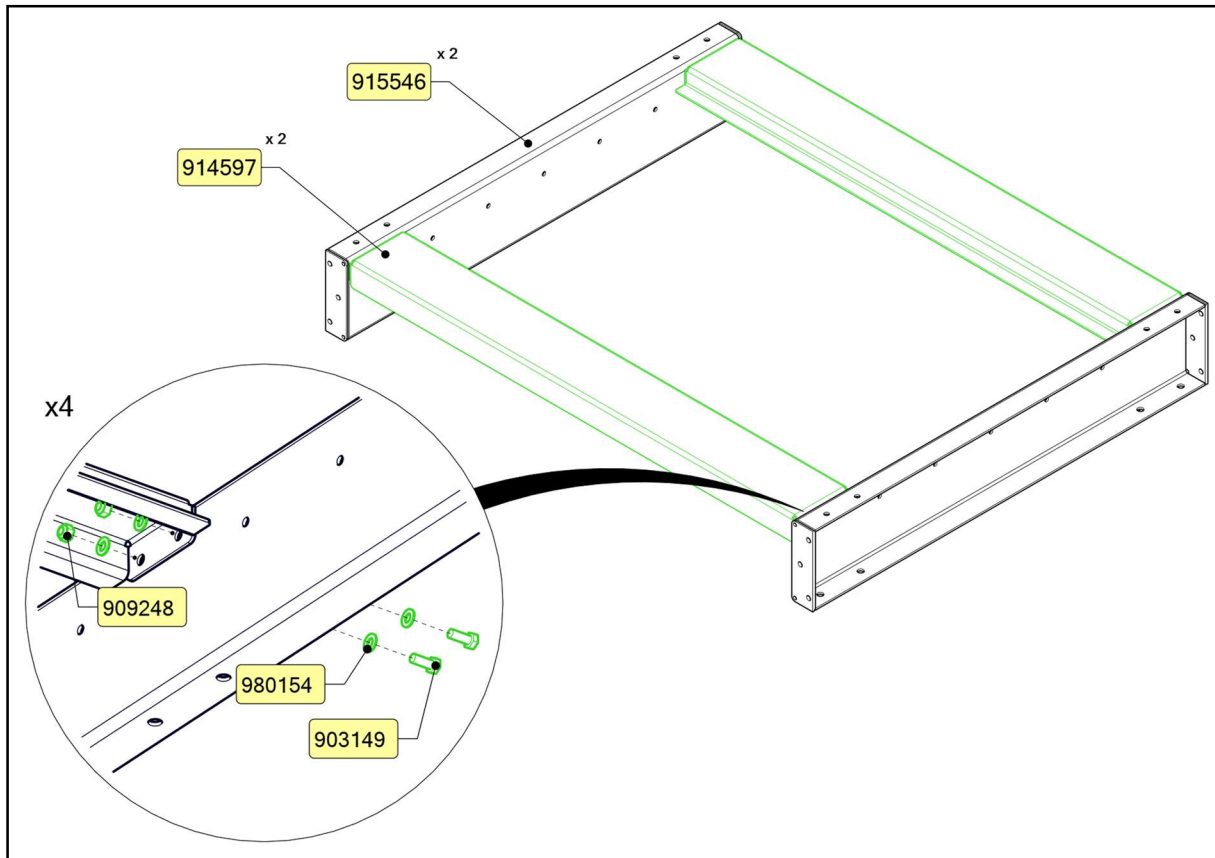

## SISU FITNESS STAIRS

### FLOOR-1 (1 PC)

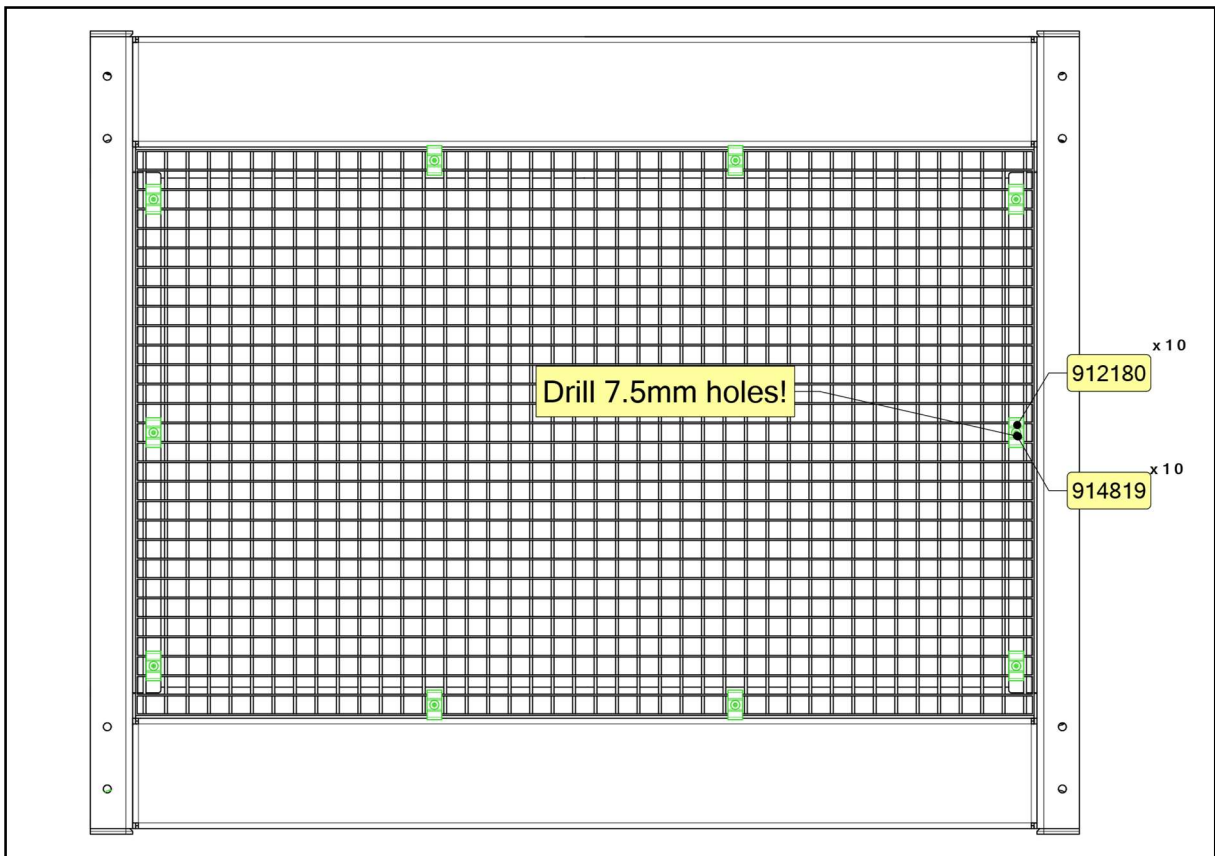
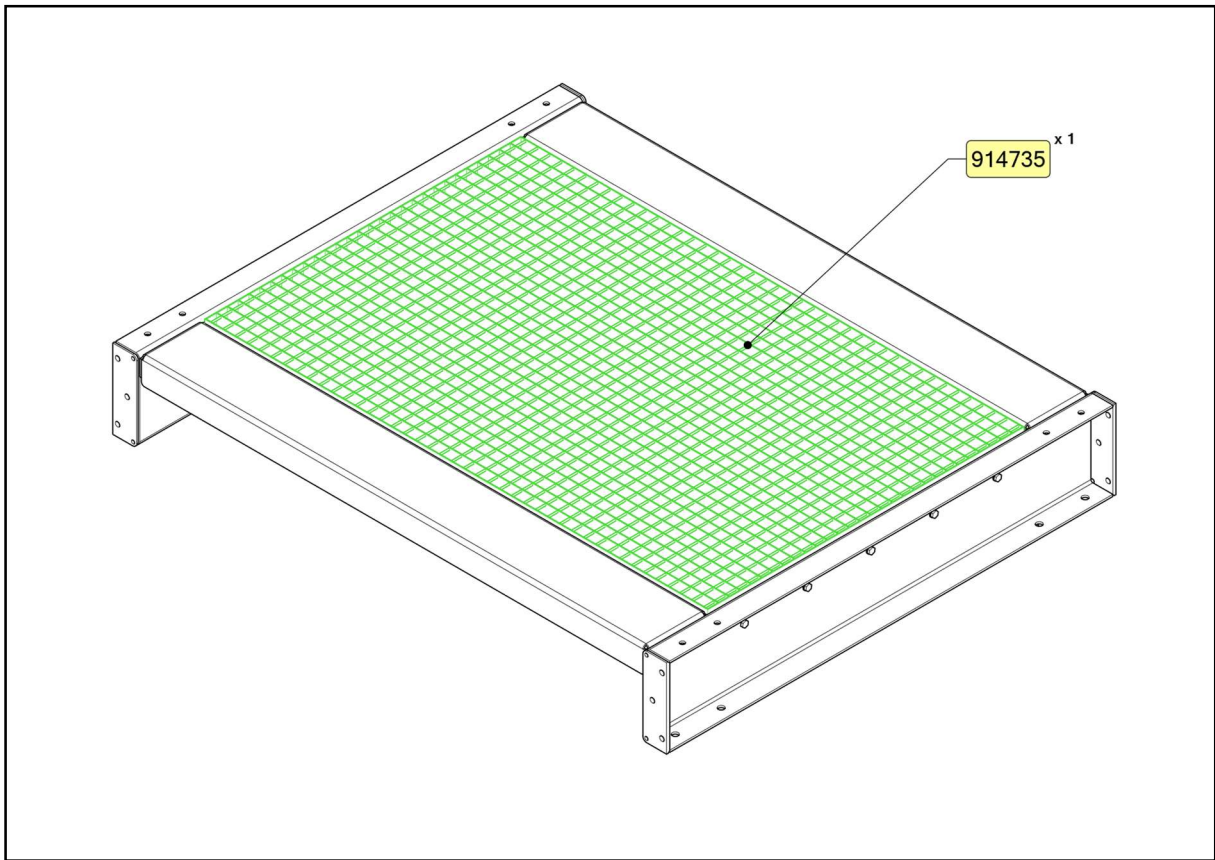

## SISU FITNESS STAIRS

### FLOOR-1 (1 PC)

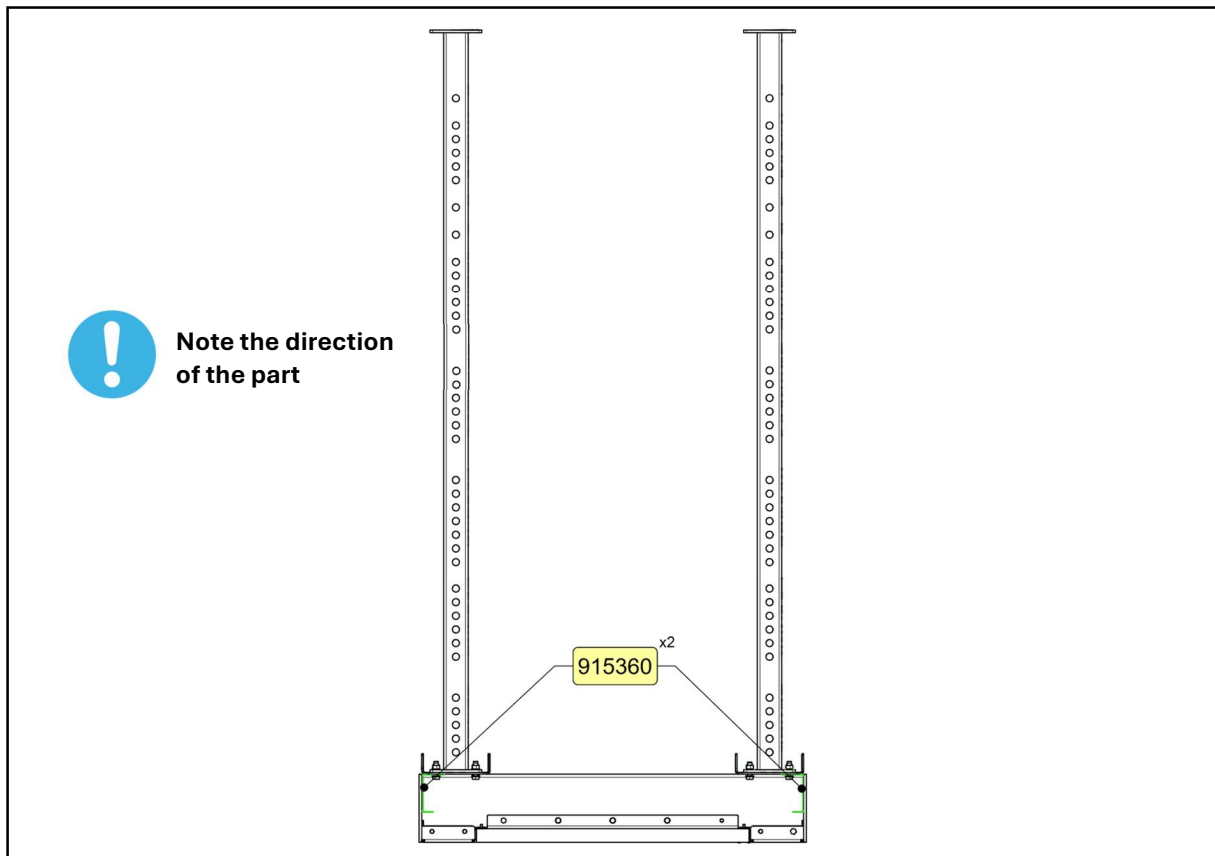
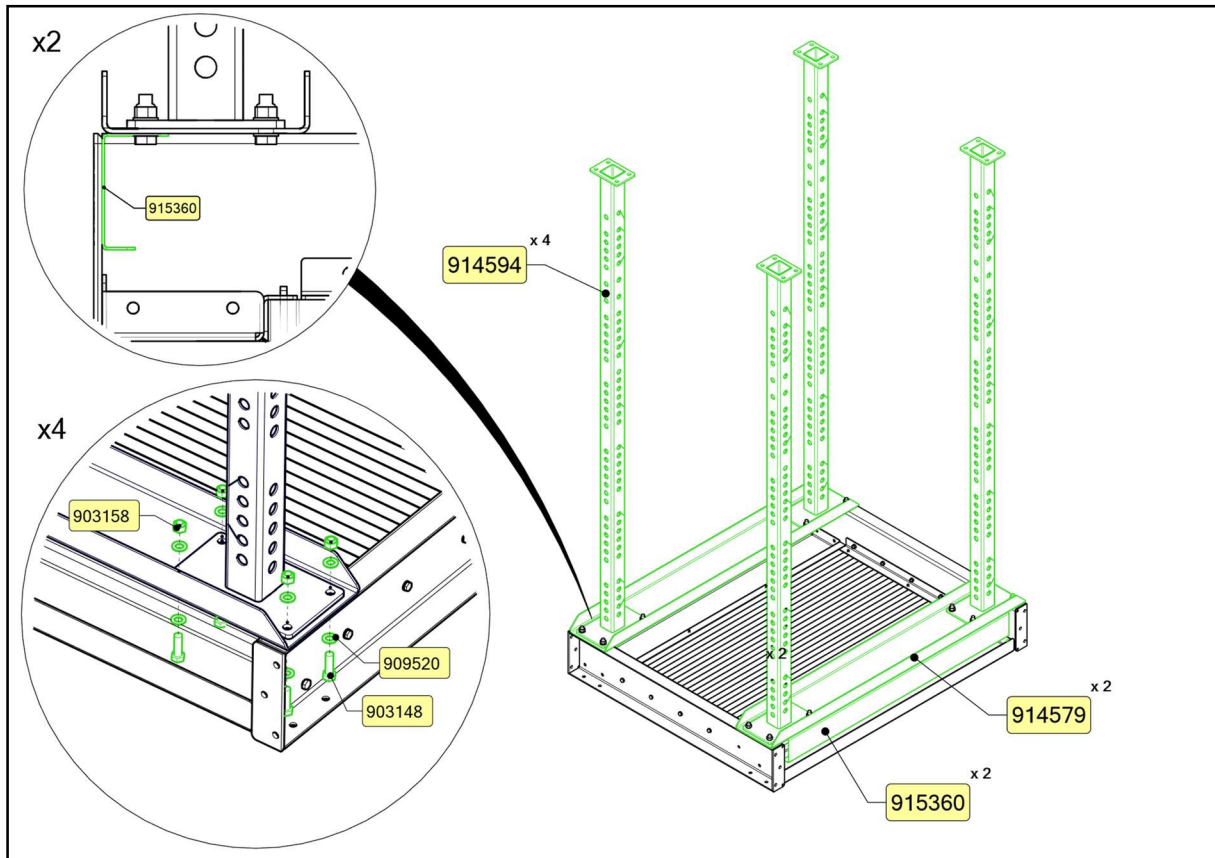

**SISU FITNESS STAIRS**

**FLOOR-1 (1 PC)**

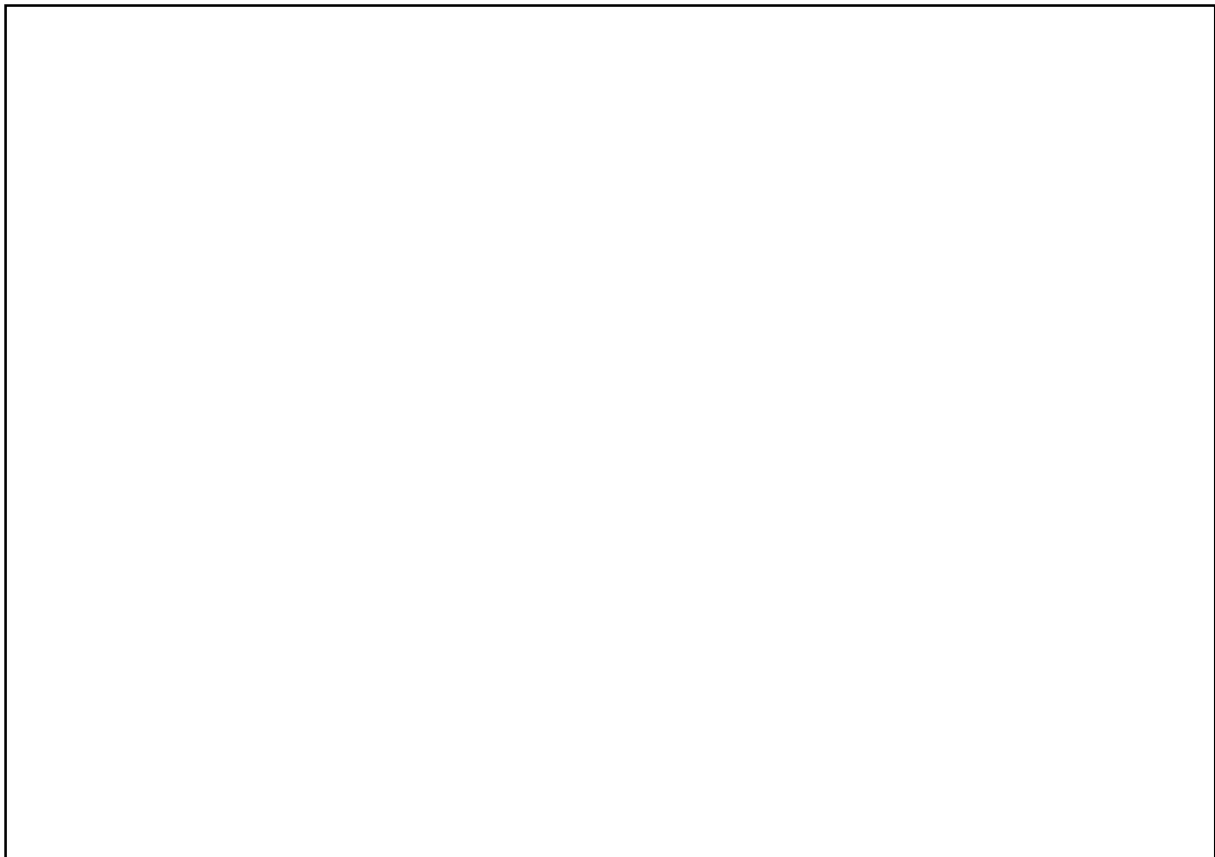
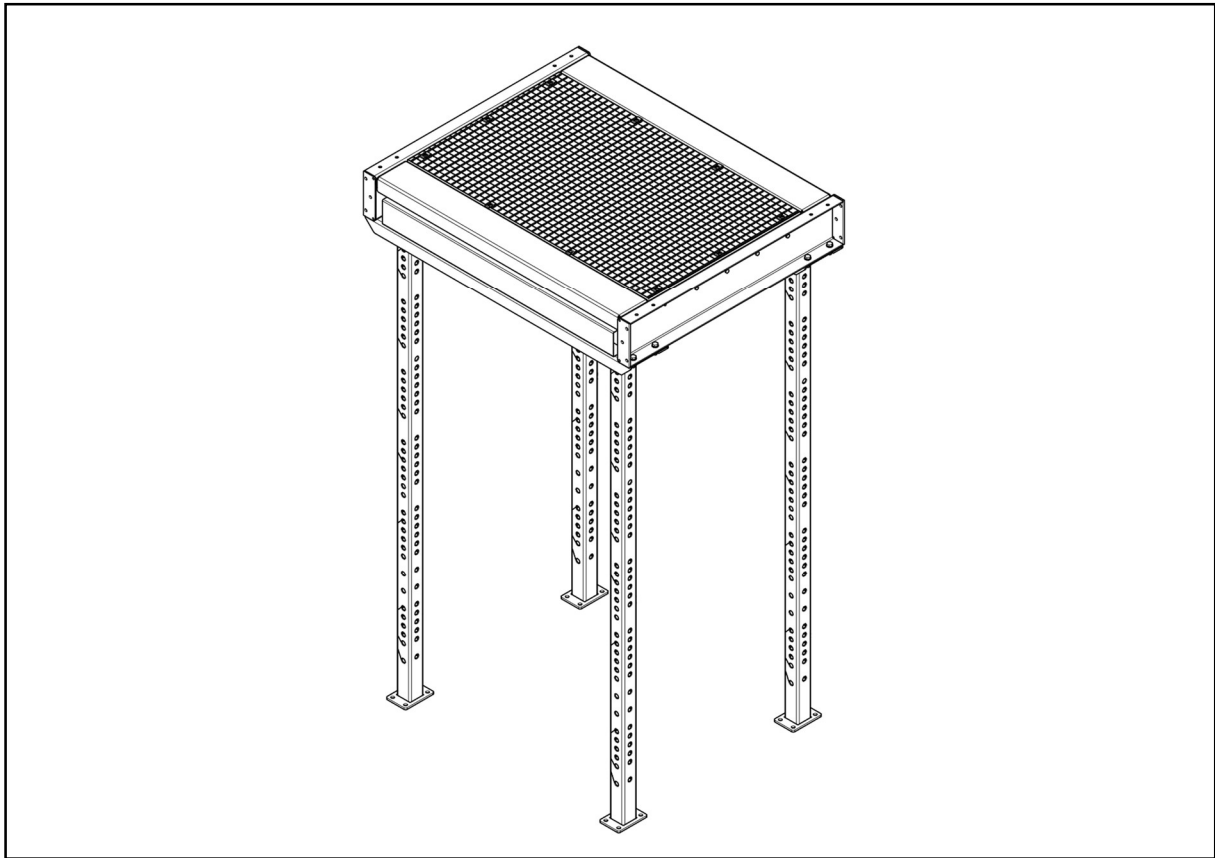

## SISU FITNESS STAIRS

### FLOOR-2 (1 PC)

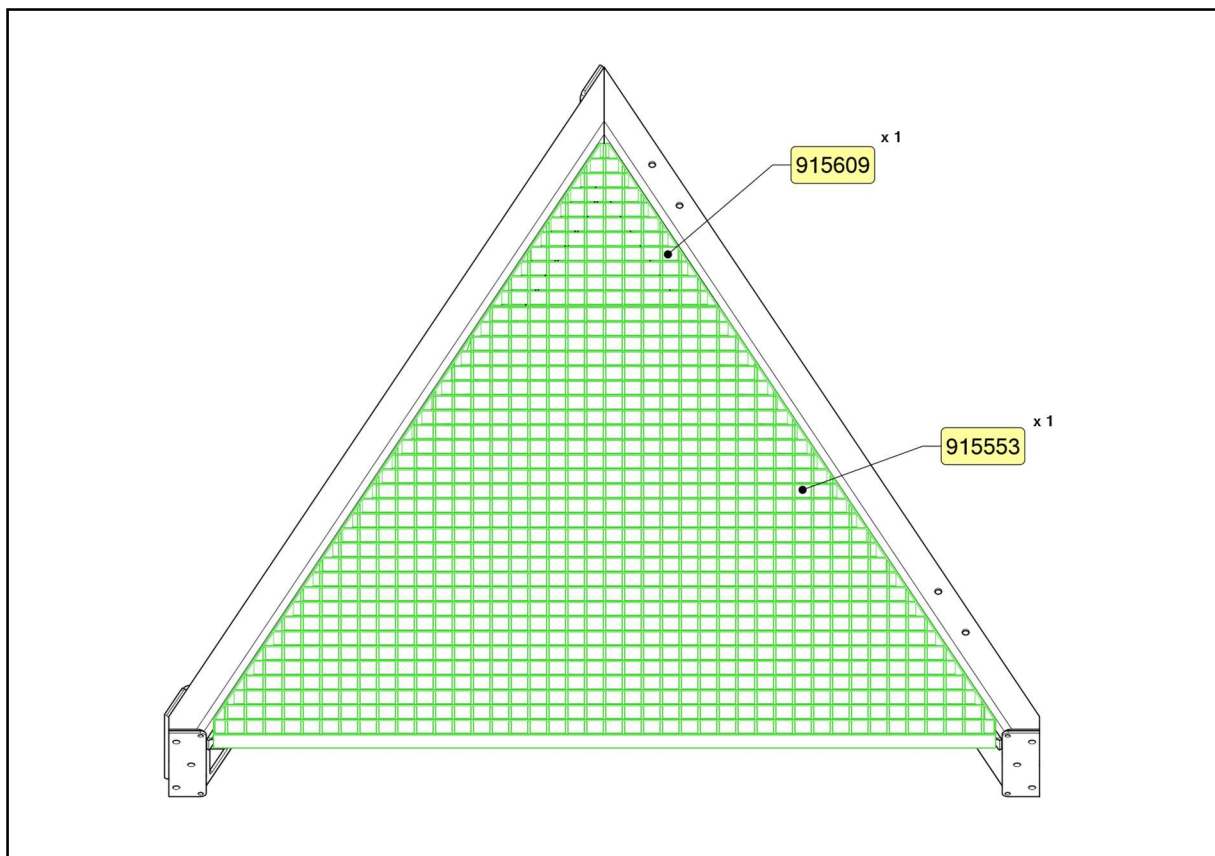
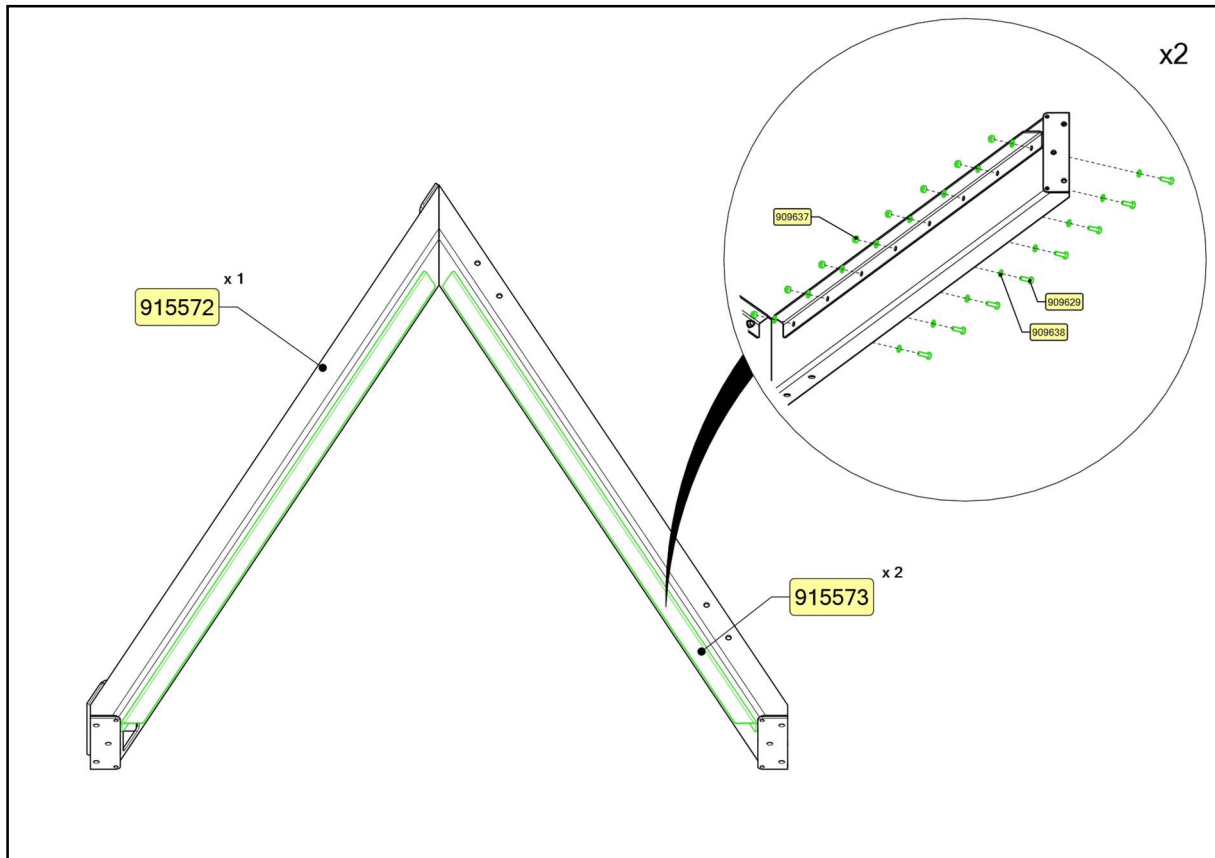

## SISU FITNESS STAIRS

### FLOOR-2 (1 PC)

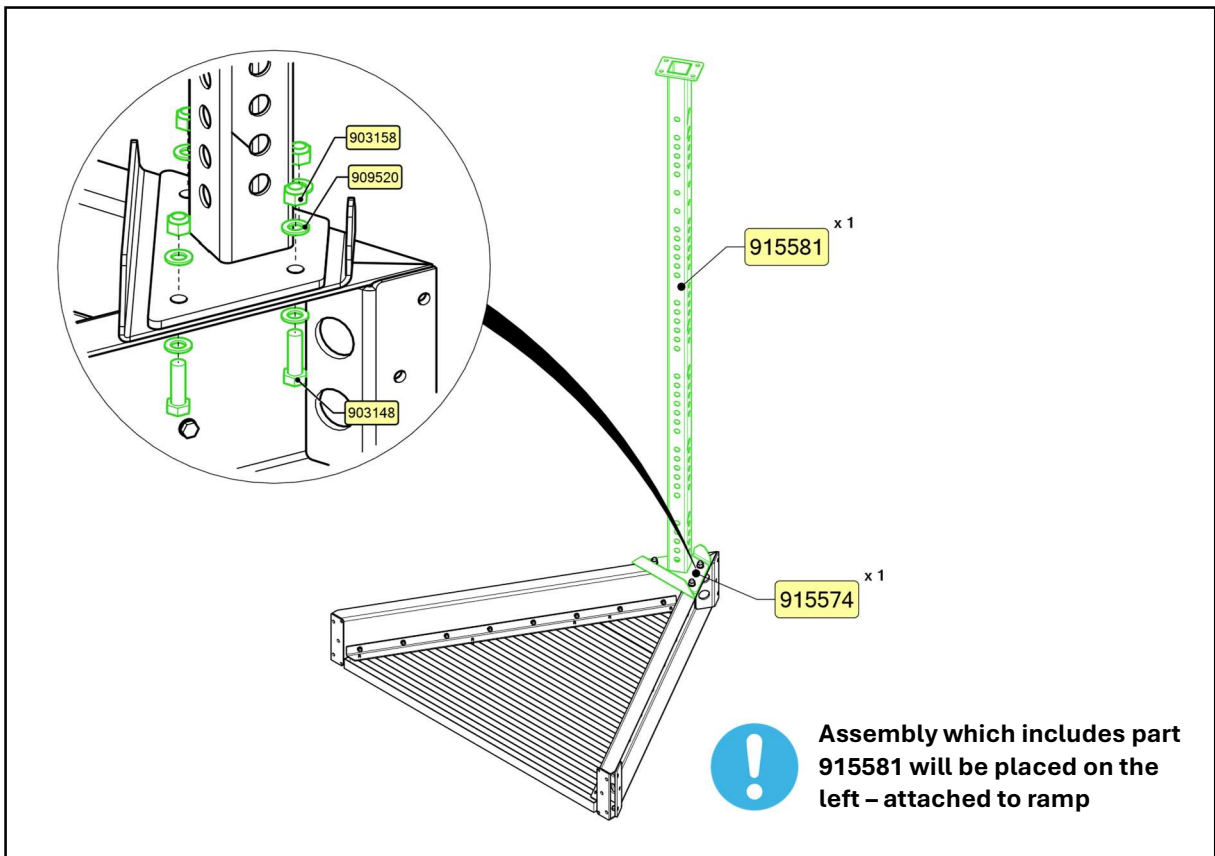
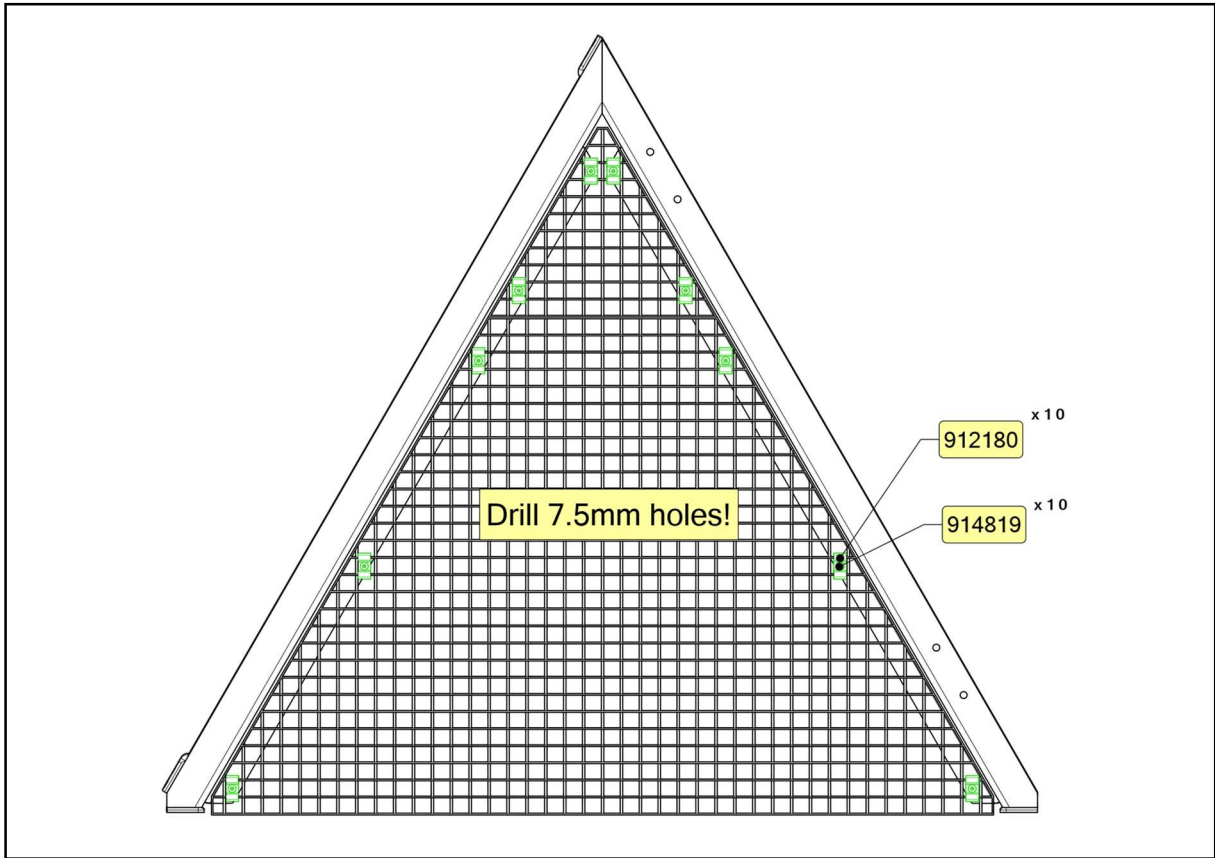

## SISU FITNESS STAIRS

### FLOOR-2 (1 PC)

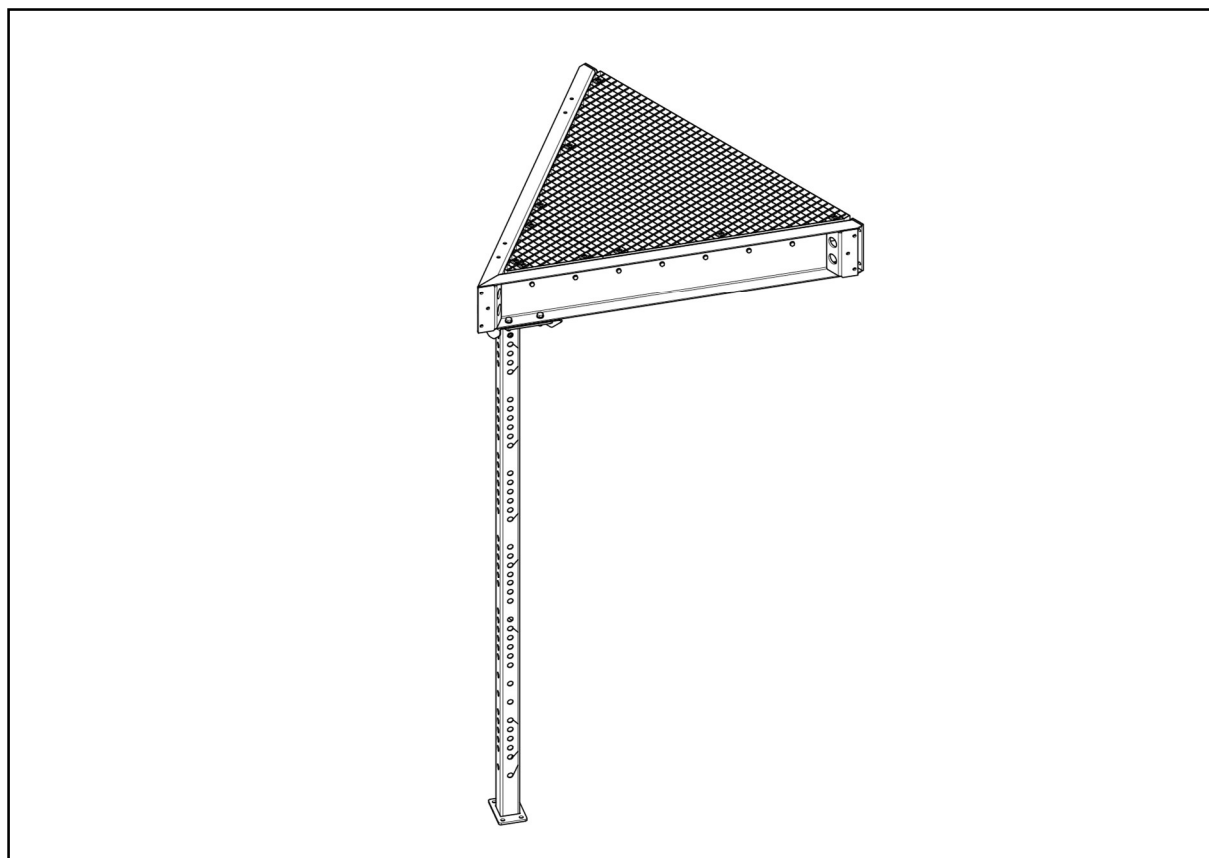
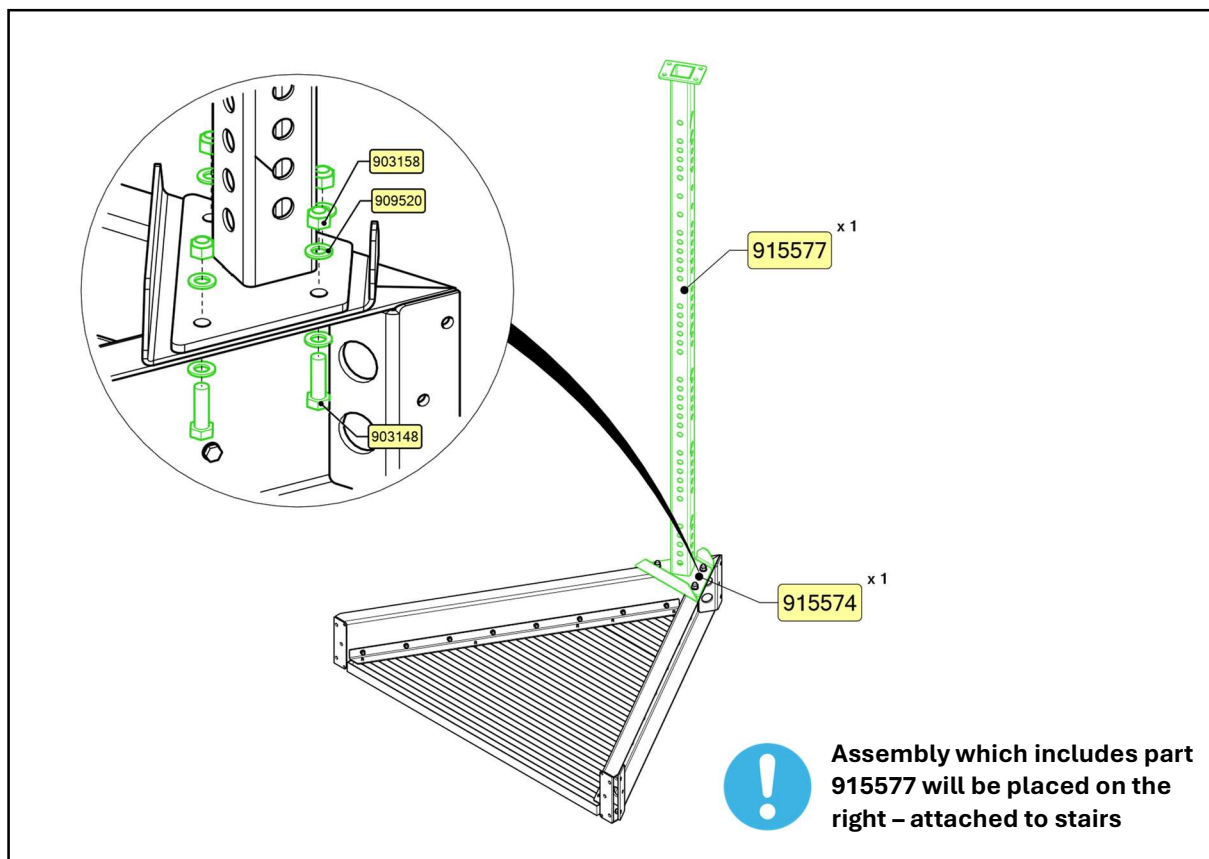

## SISU FITNESS STAIRS

### ASSEMBLY

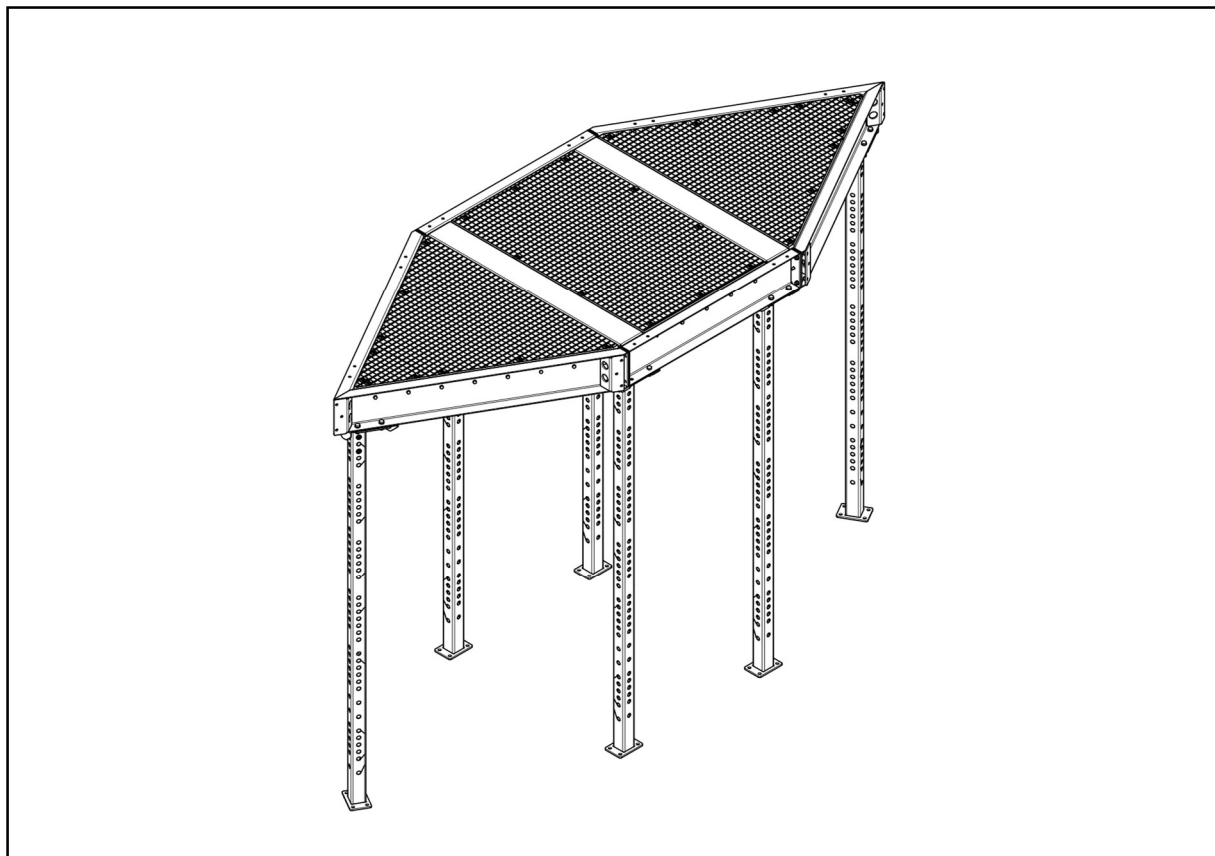
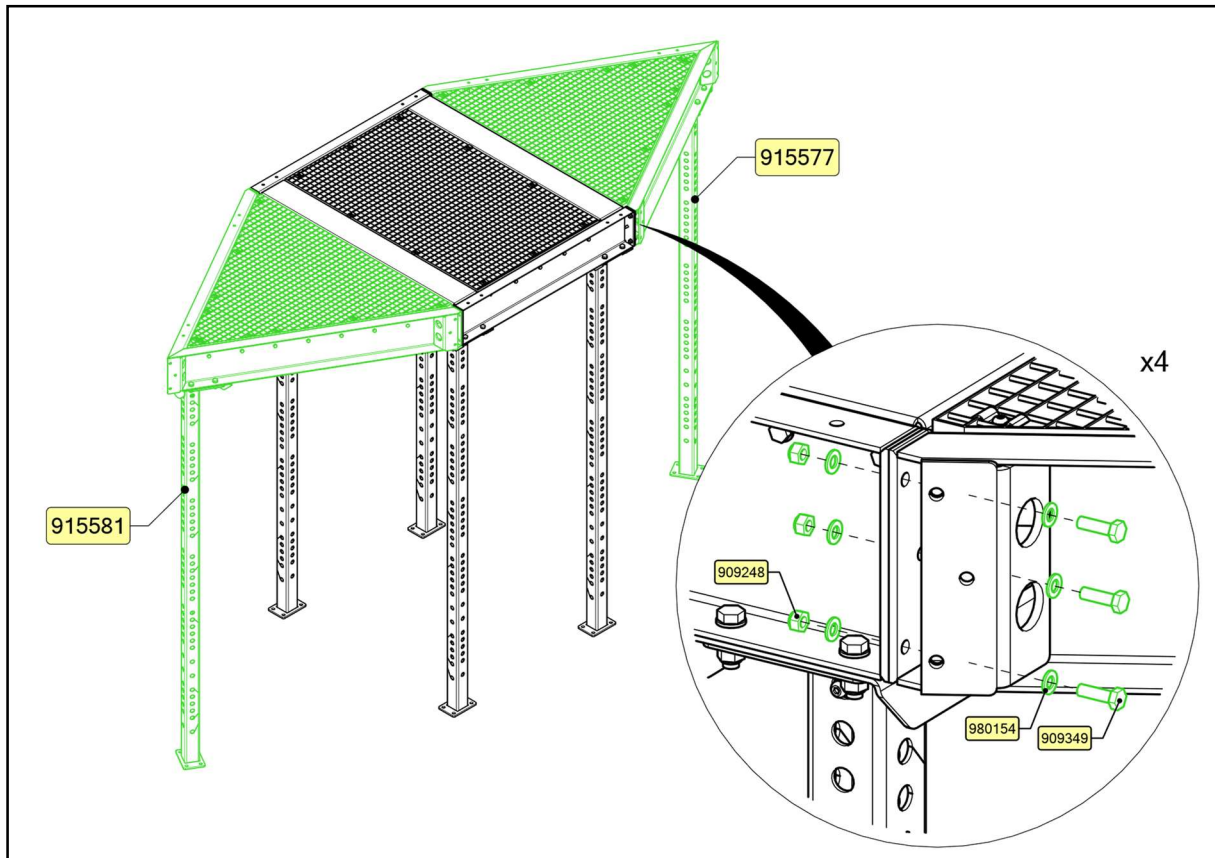

## SISU FITNESS STAIRS

### ASSEMBLY

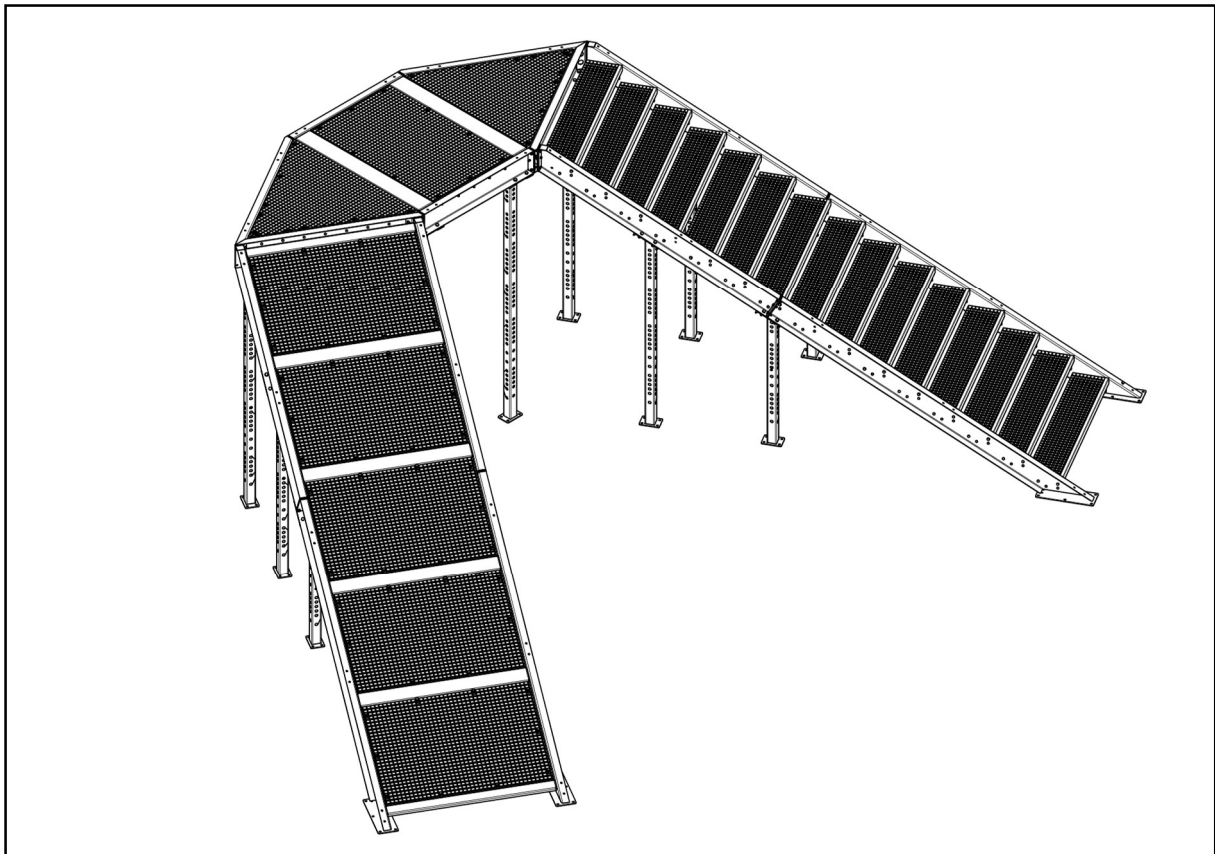
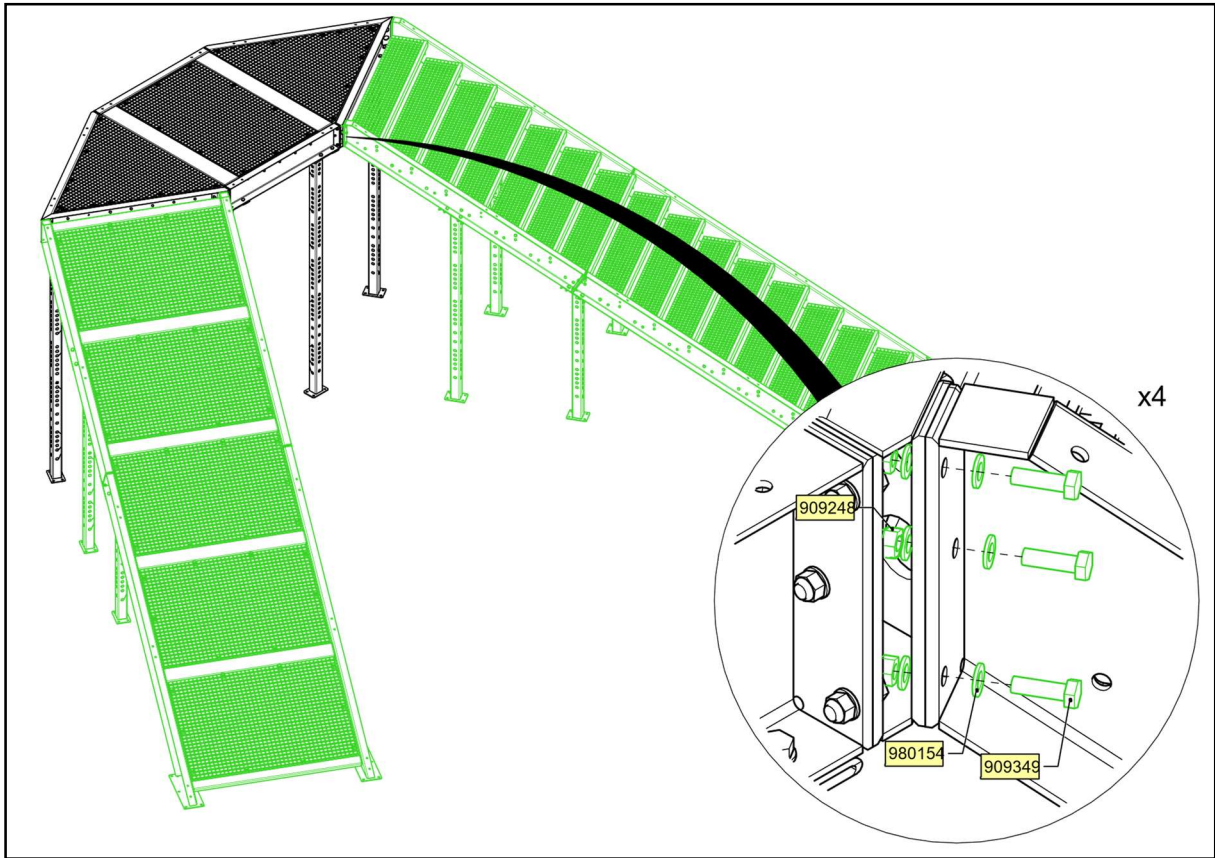

**SISU FITNESS STAIRS**

**HANDRAIL (4 PCS)**

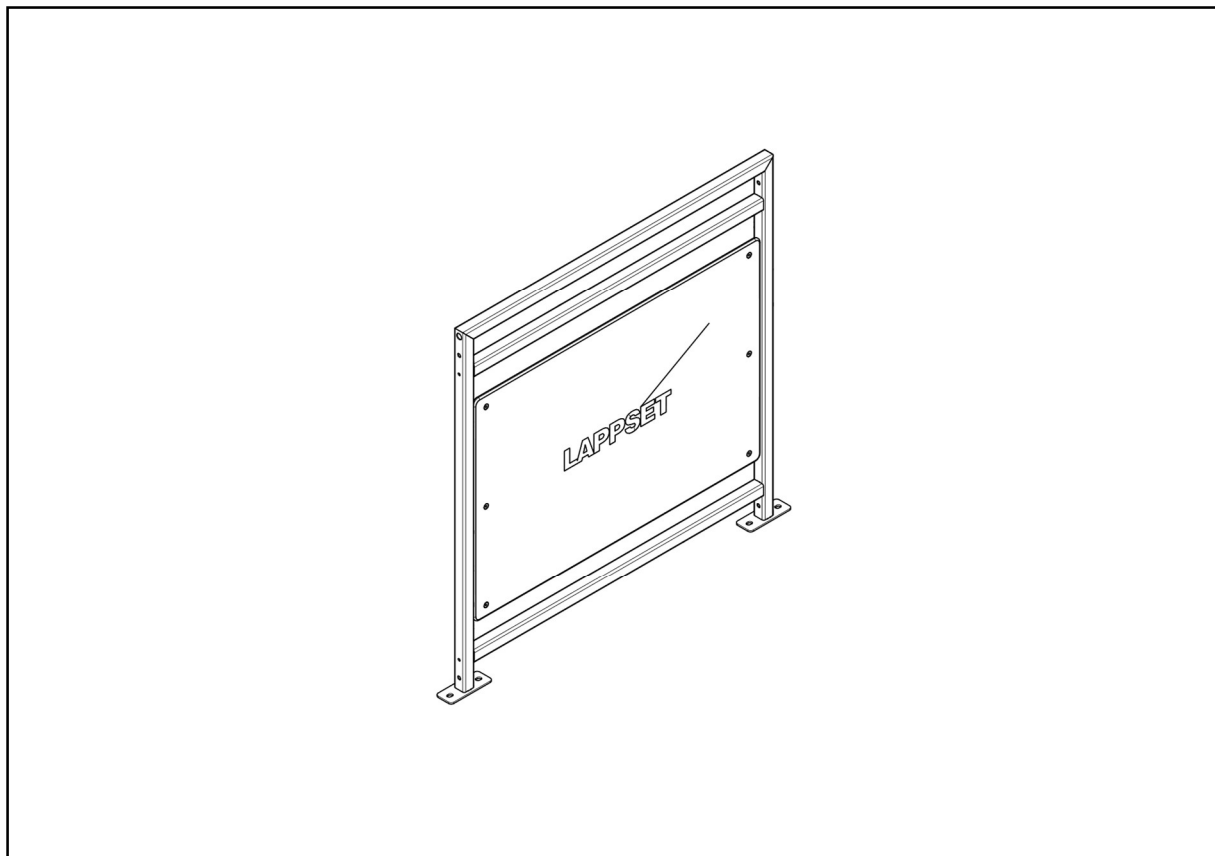
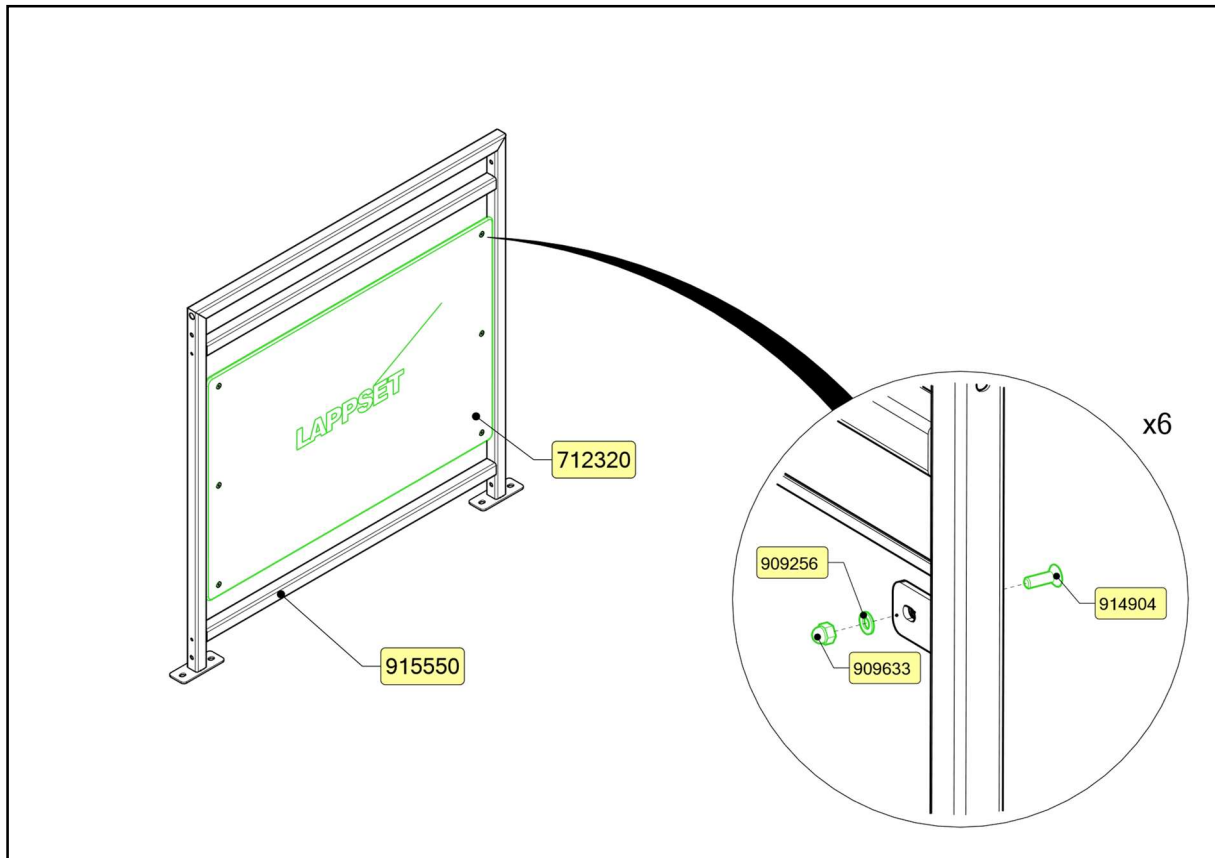

## SISU FITNESS STAIRS

### ASSEMBLY

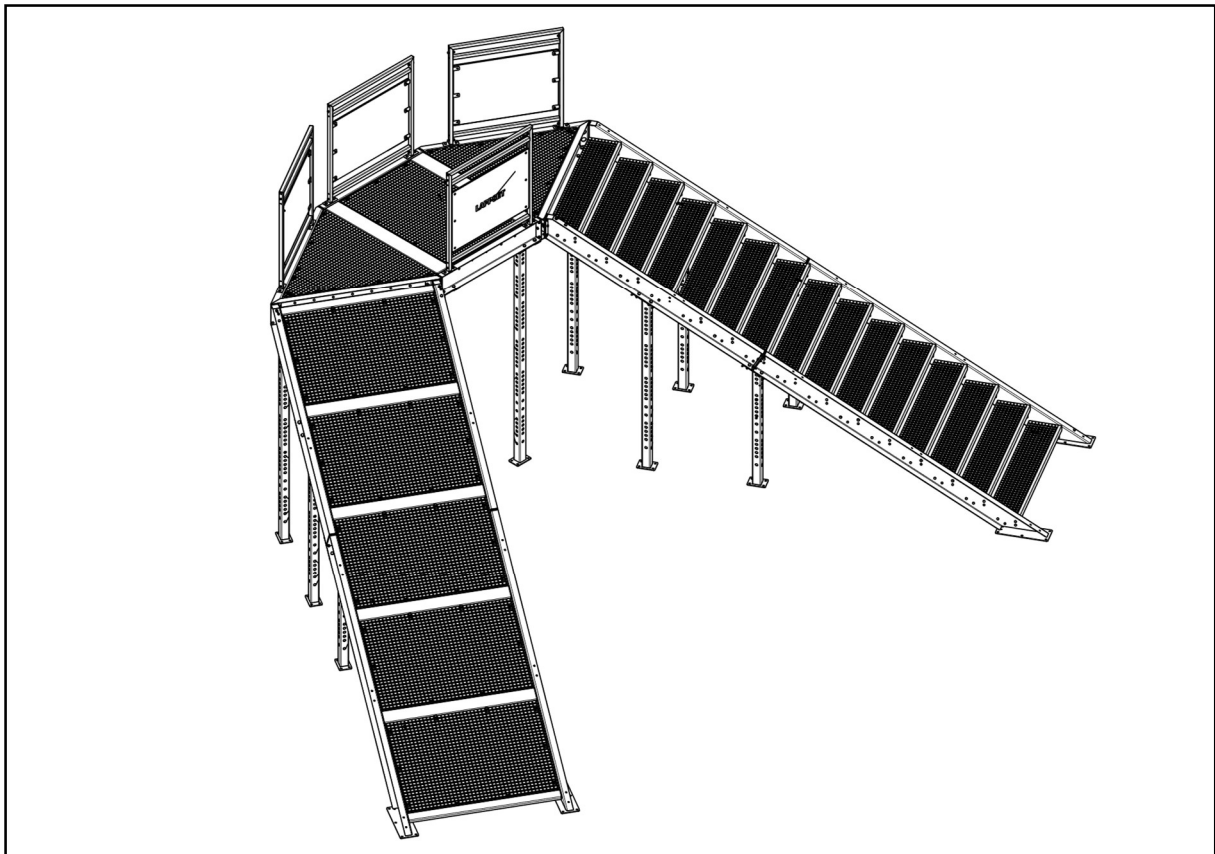
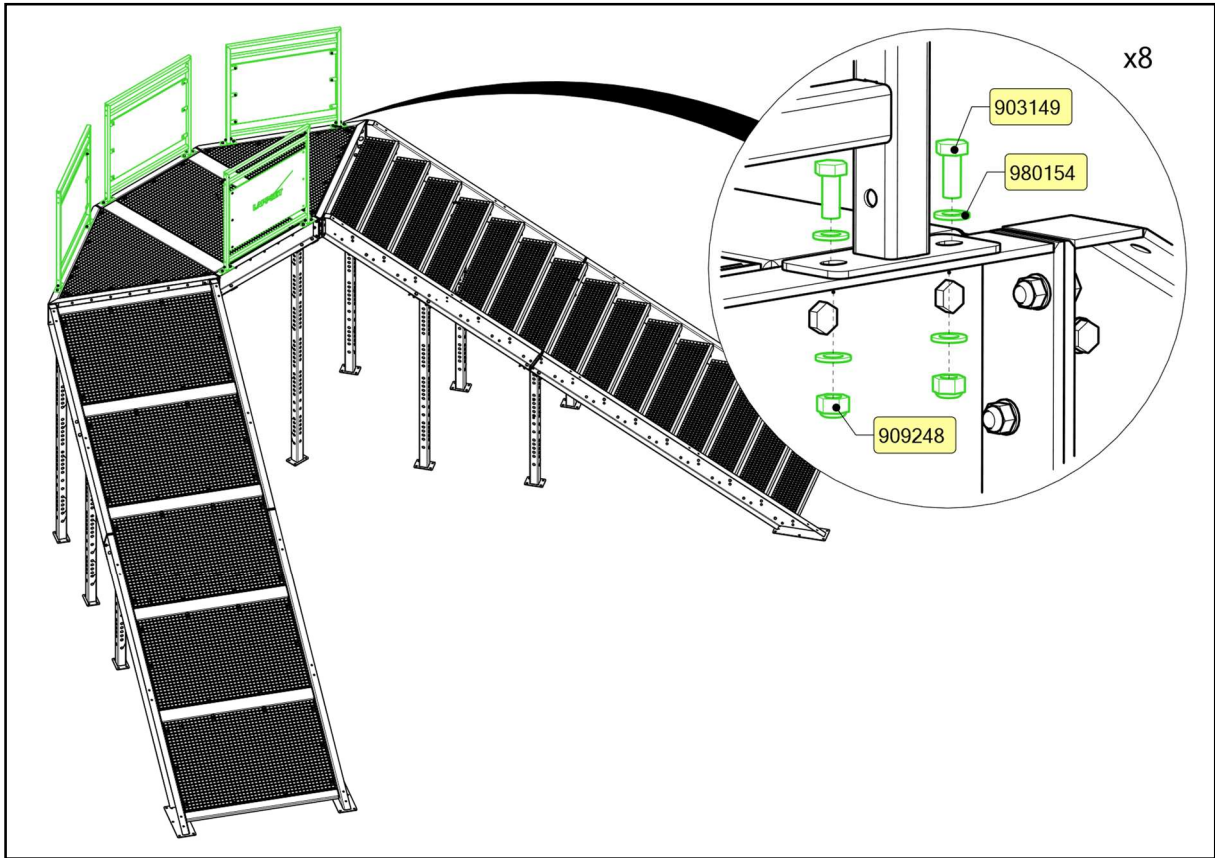

## SISU FITNESS STAIRS

### ASSEMBLY

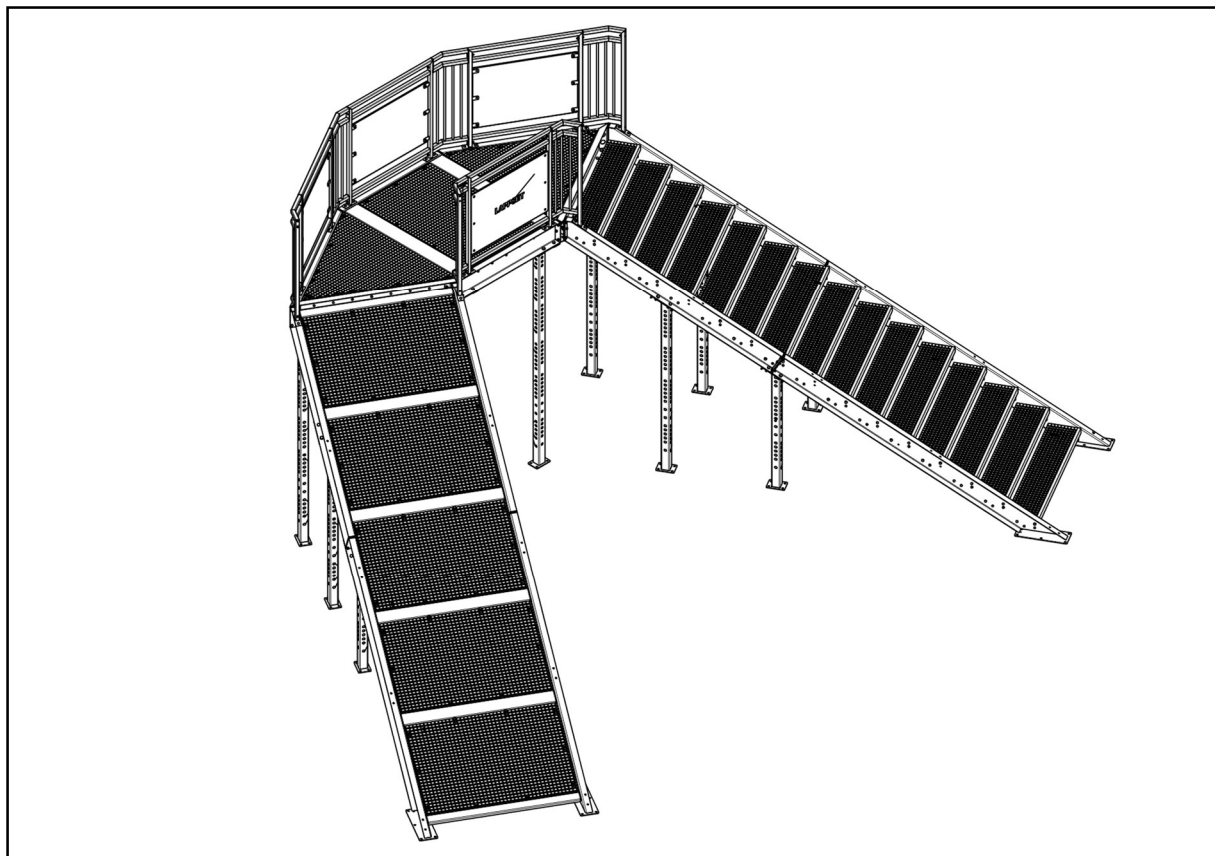
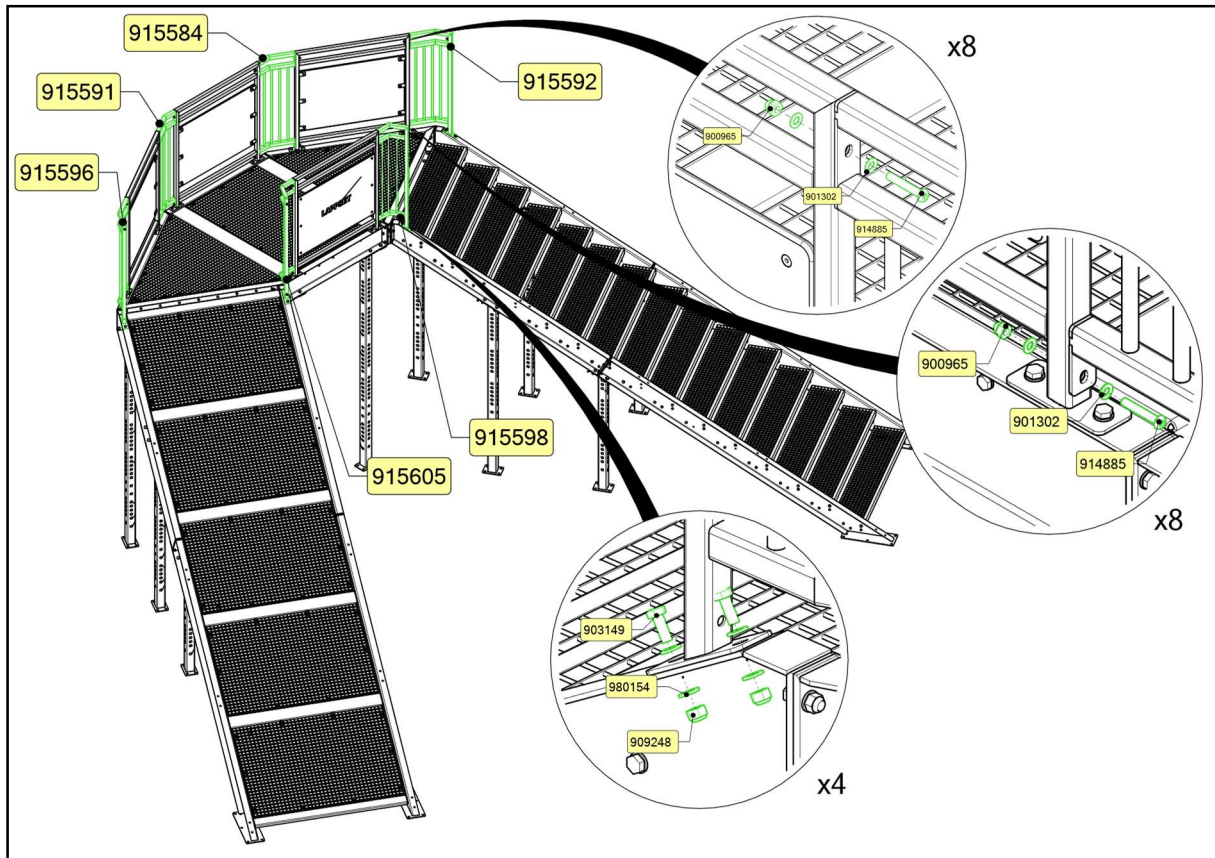

## SISU FITNESS STAIRS

### ASSEMBLY

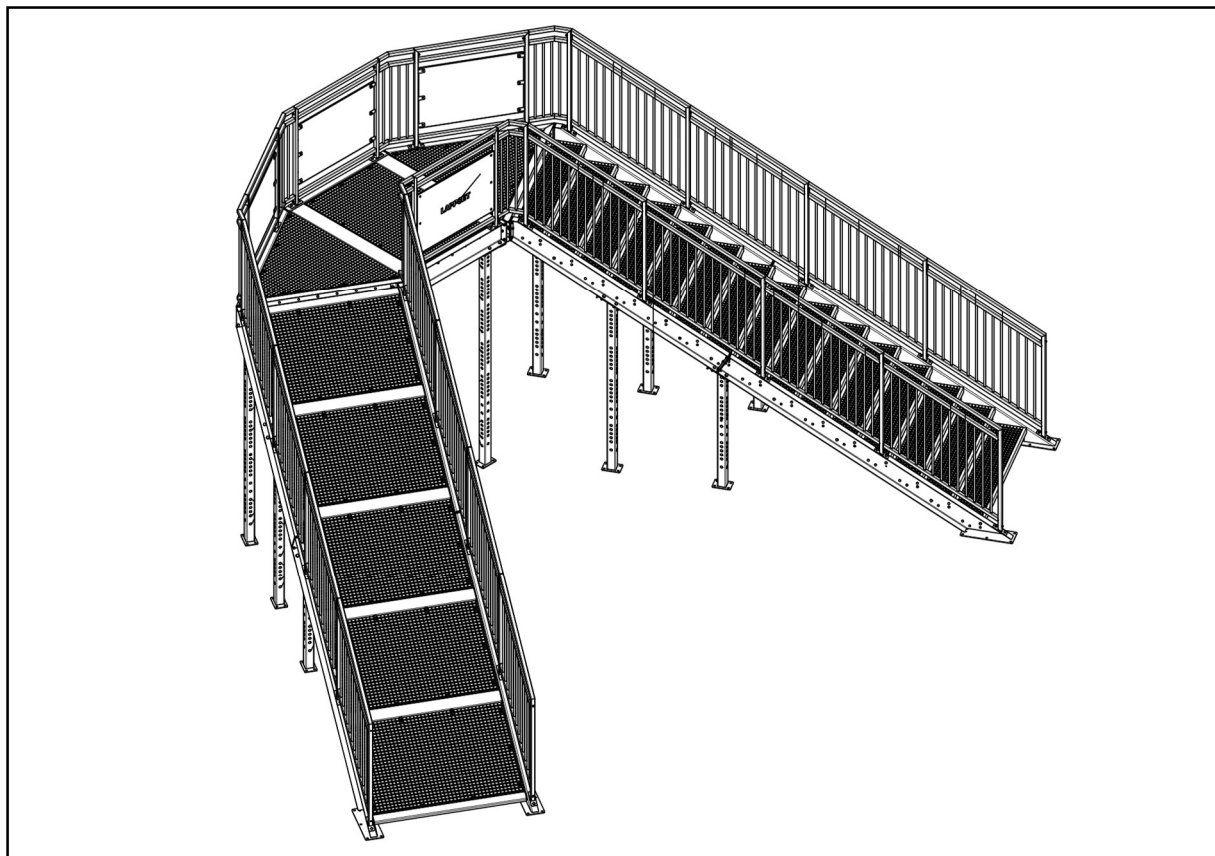
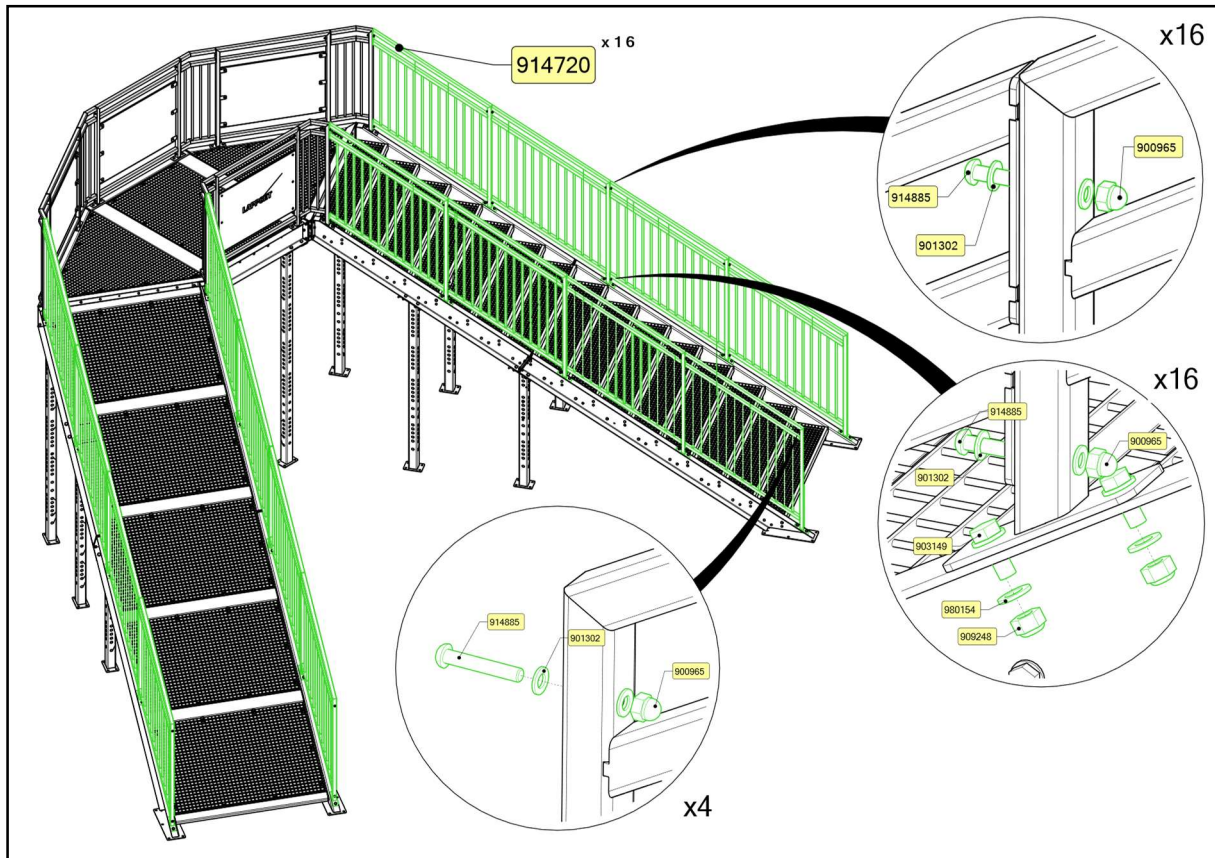

## SISU FITNESS STAIRS

### GYMNASTICS WALL

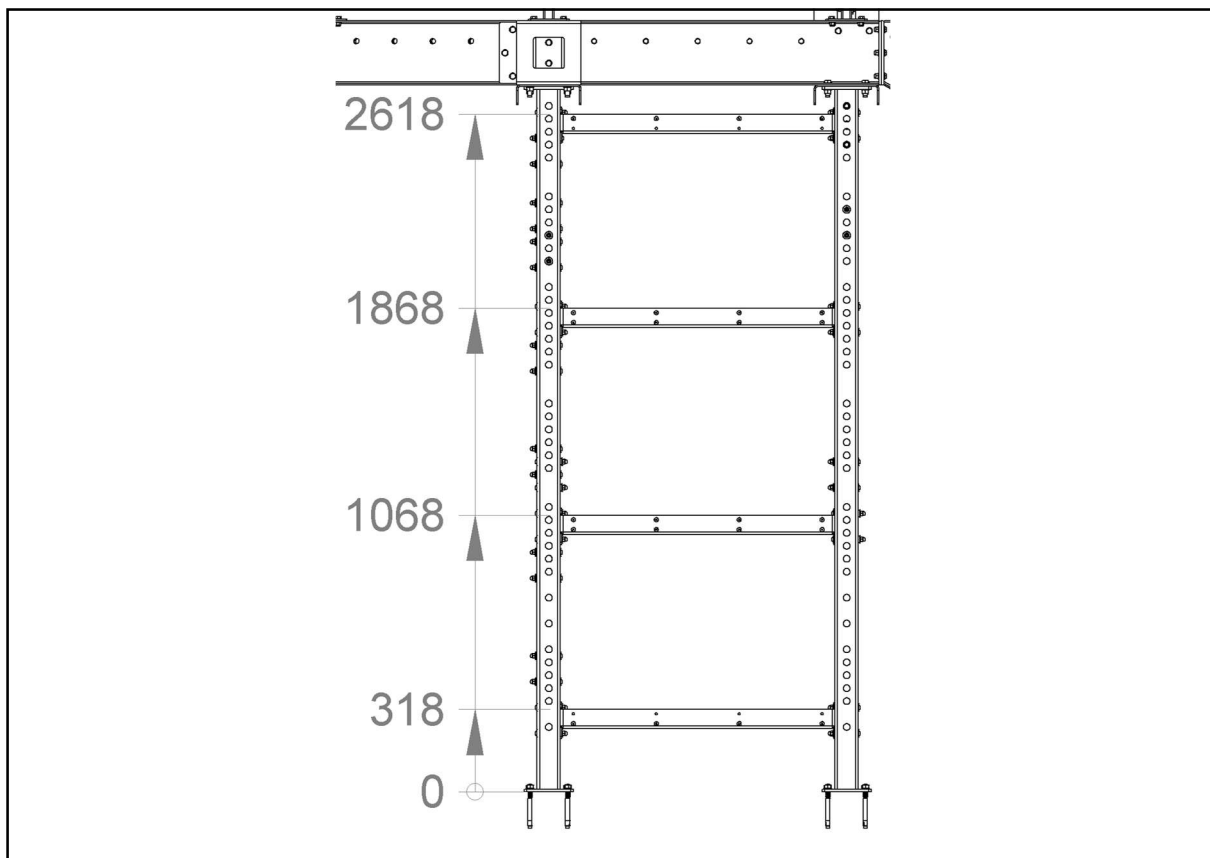
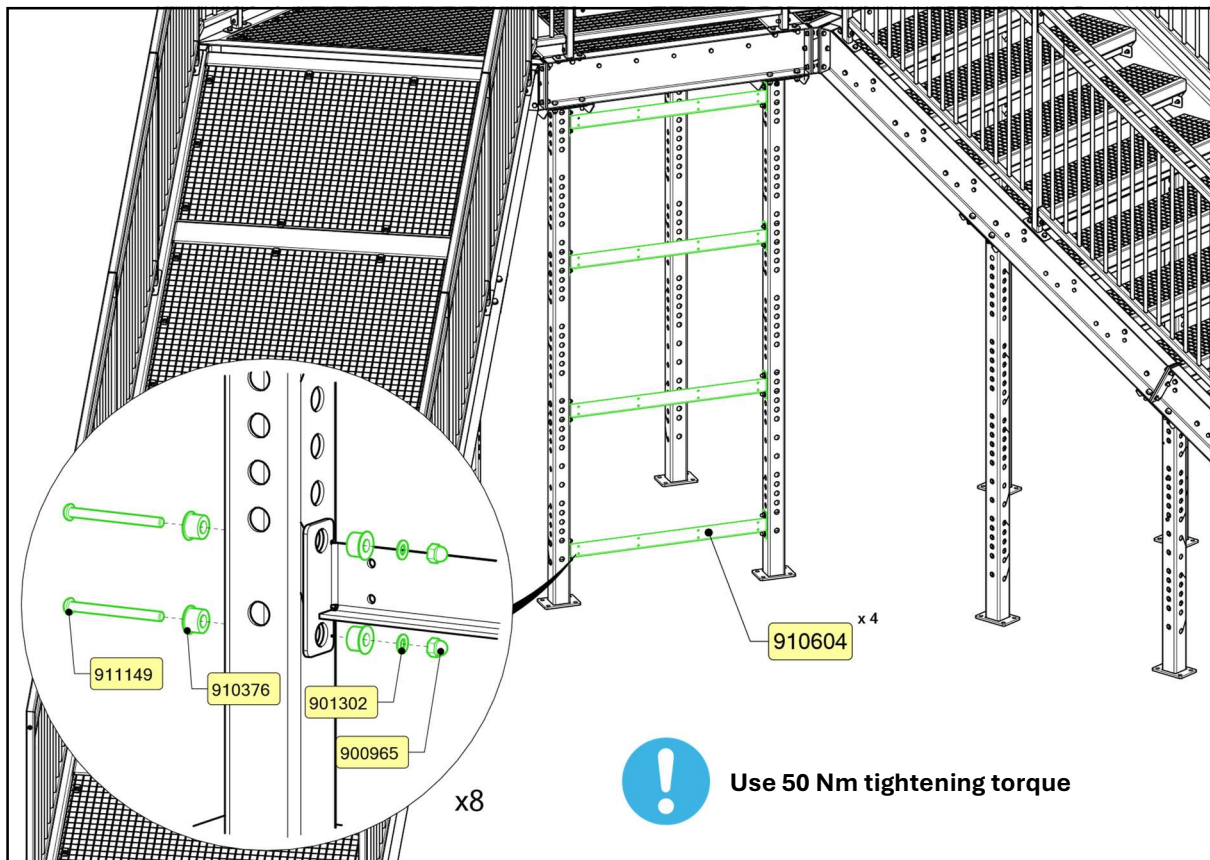

## SISU FITNESS STAIRS

### GYMNASTICS WALL

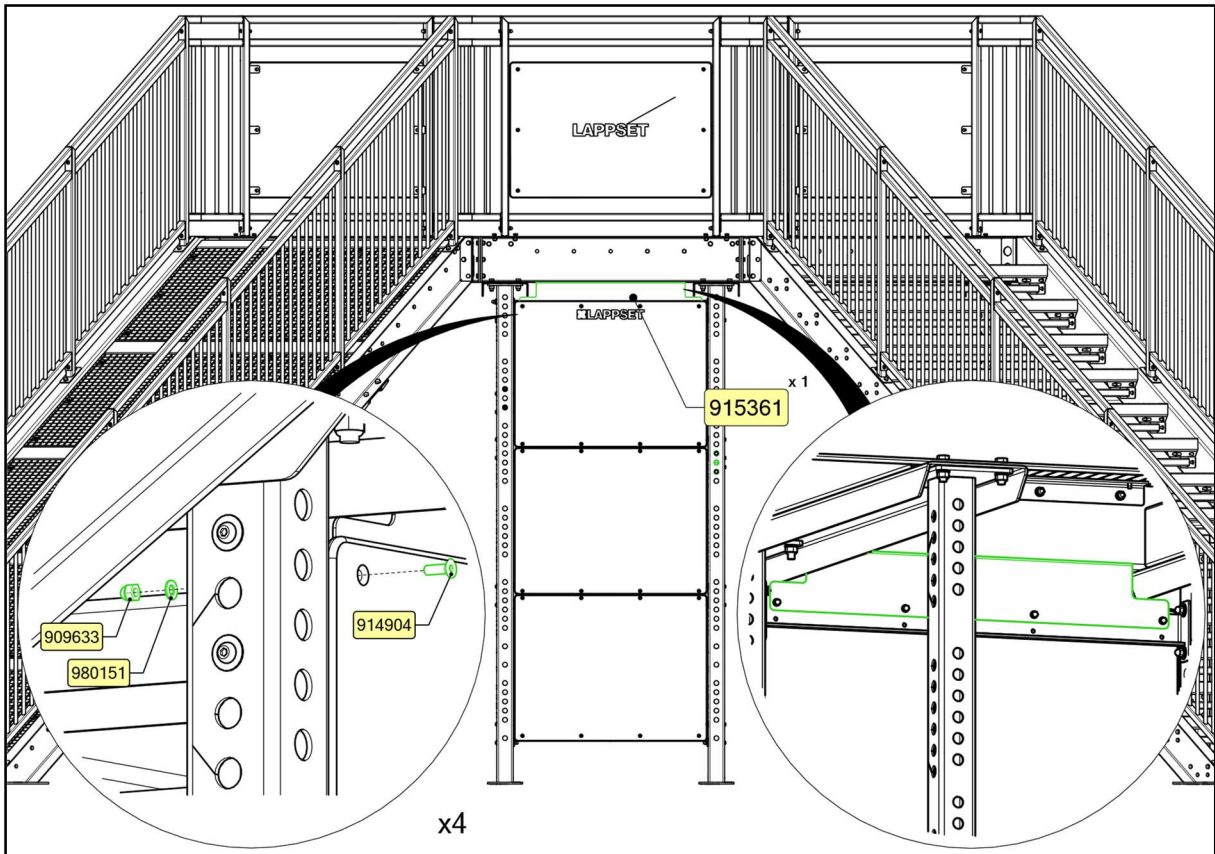
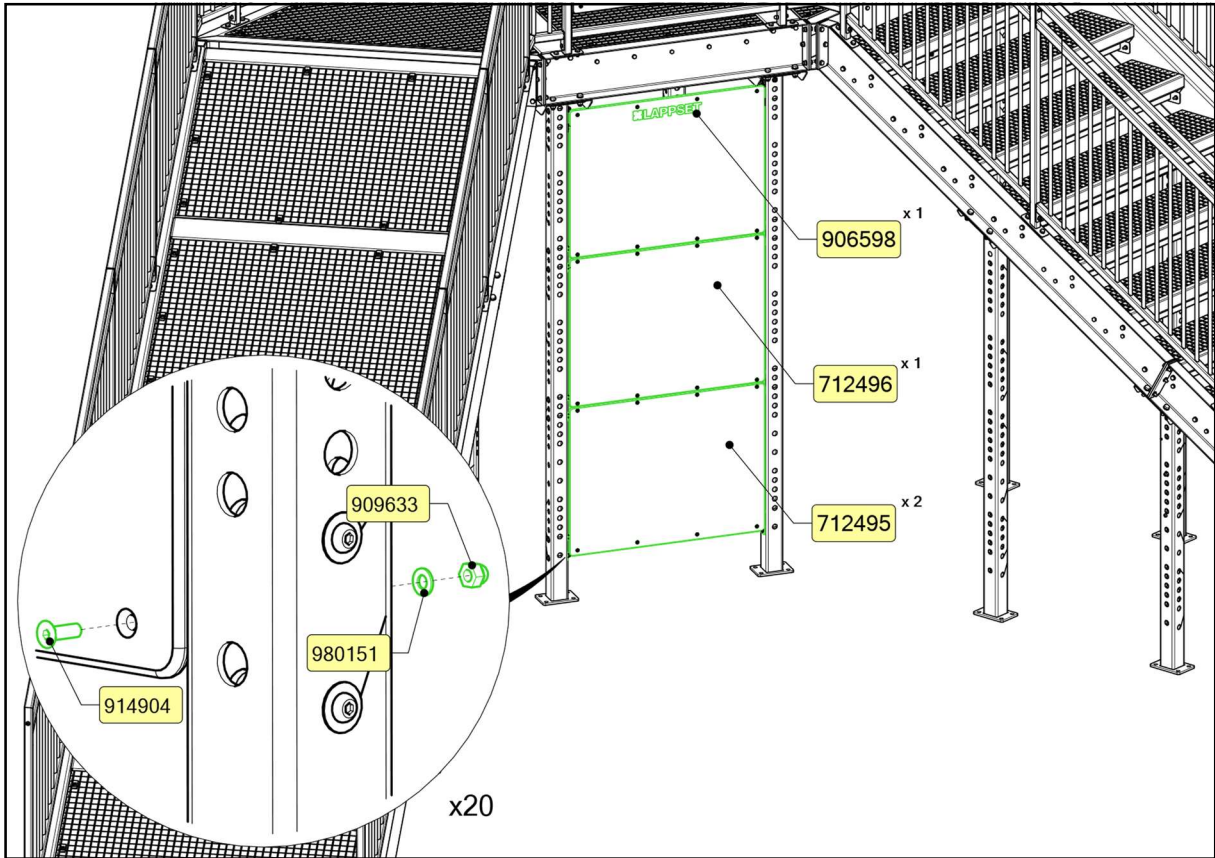

## SISU FITNESS STAIRS

### BARS-1 (1 PC)

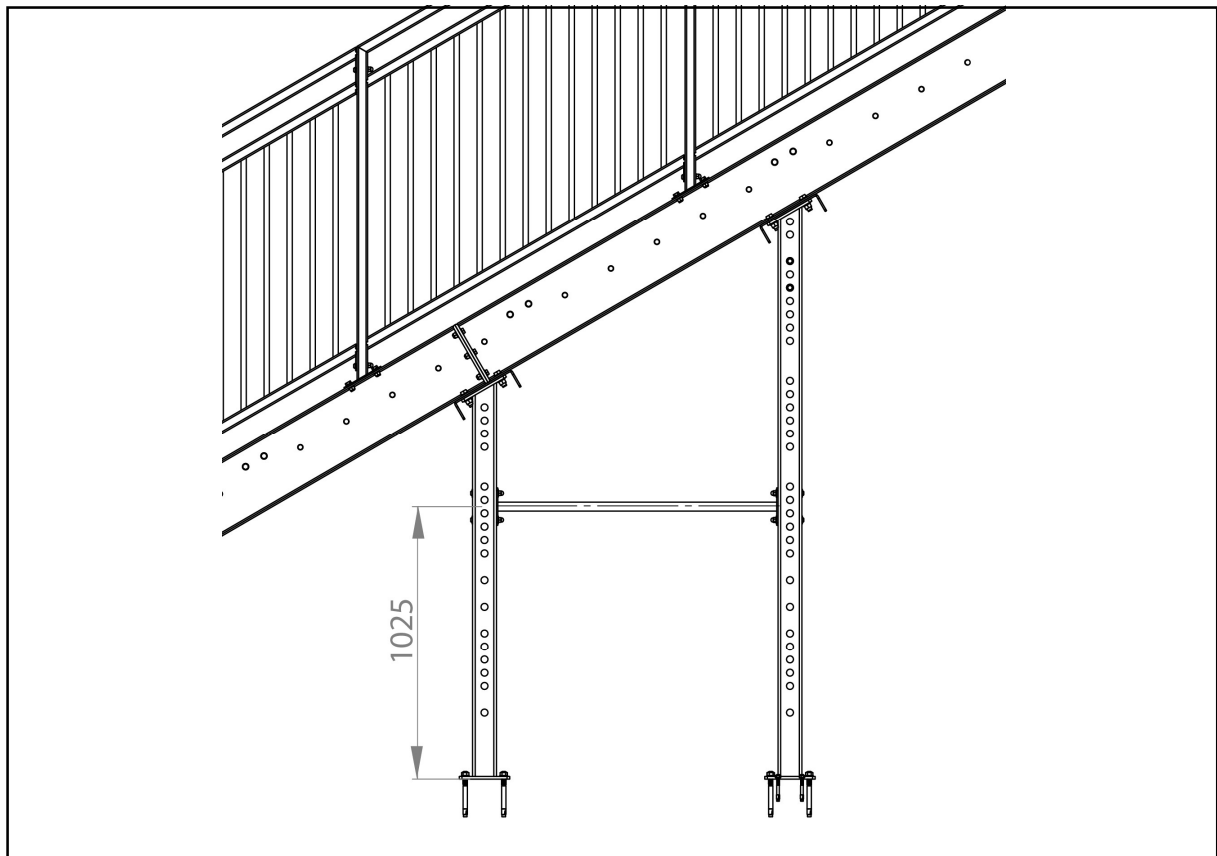
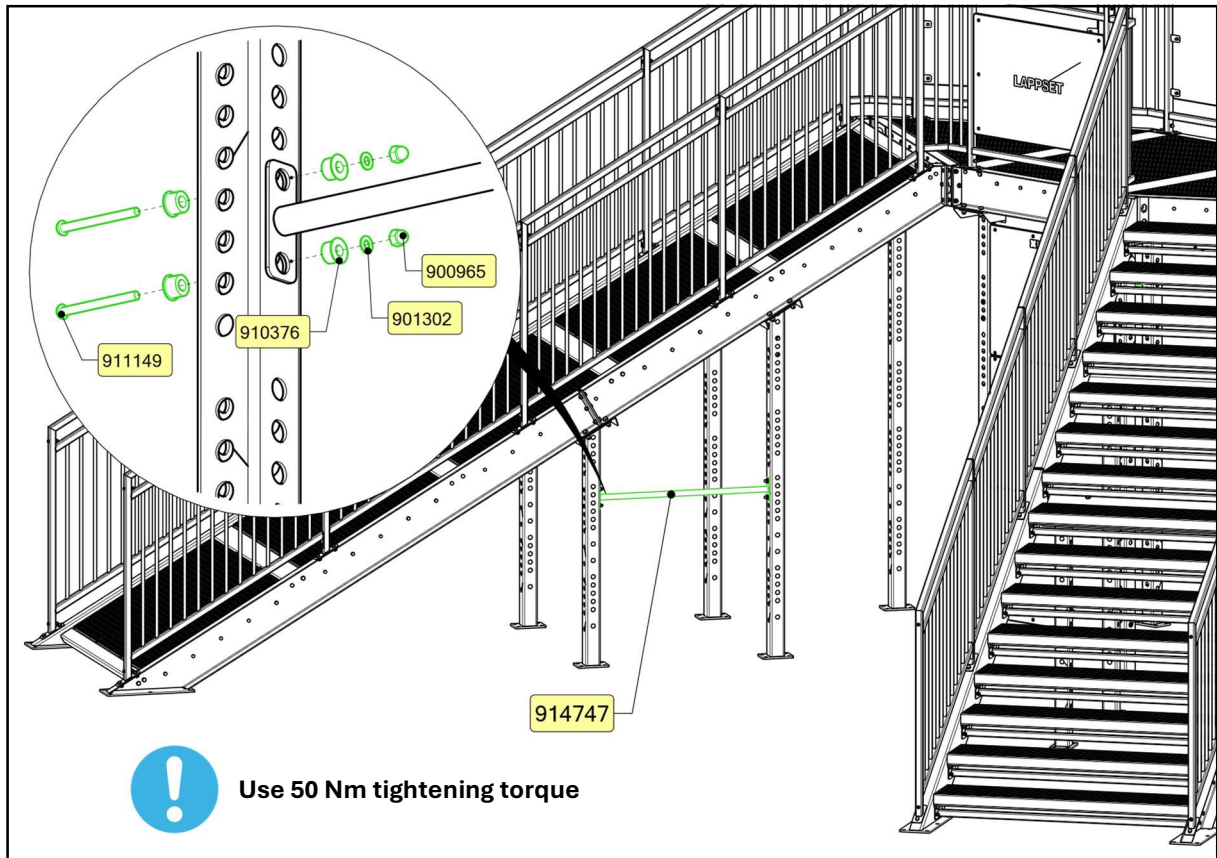

## SISU FITNESS STAIRS

### BARS-2 (2 PCS)

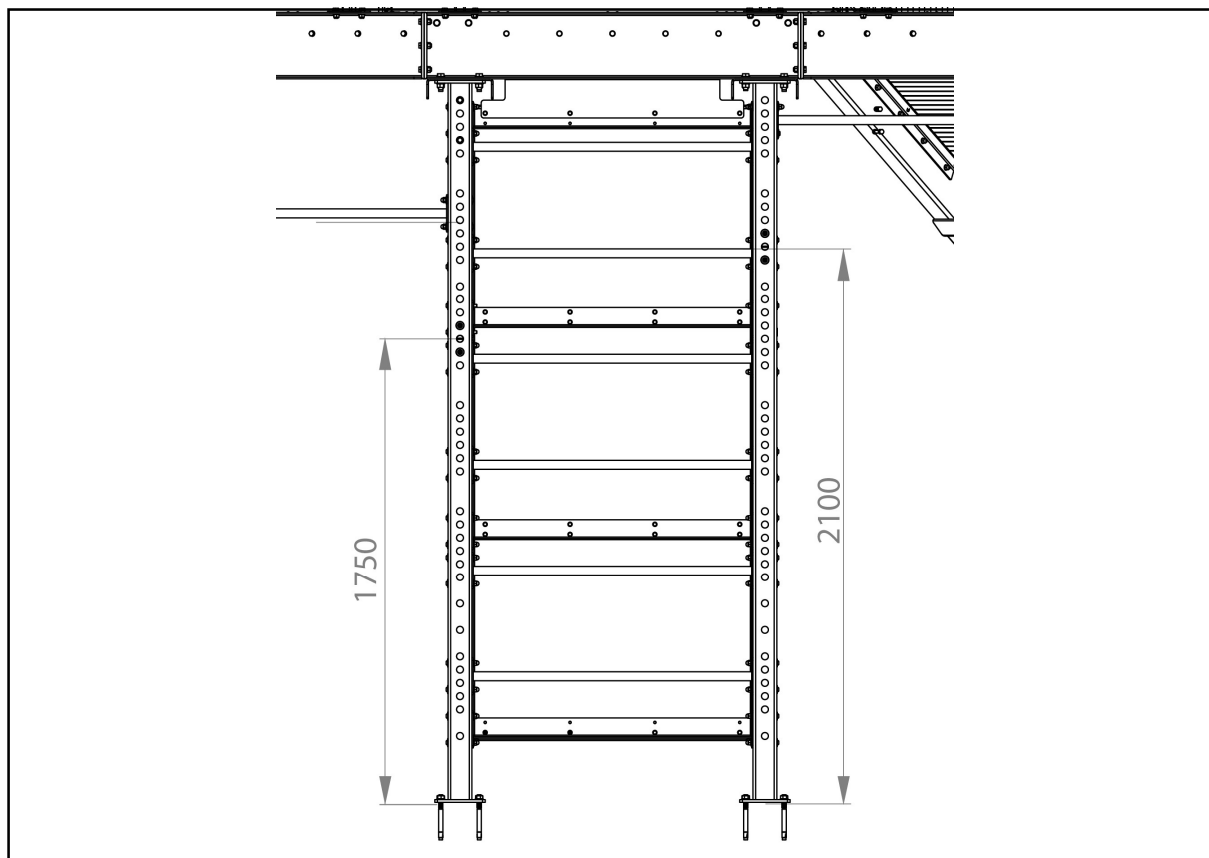
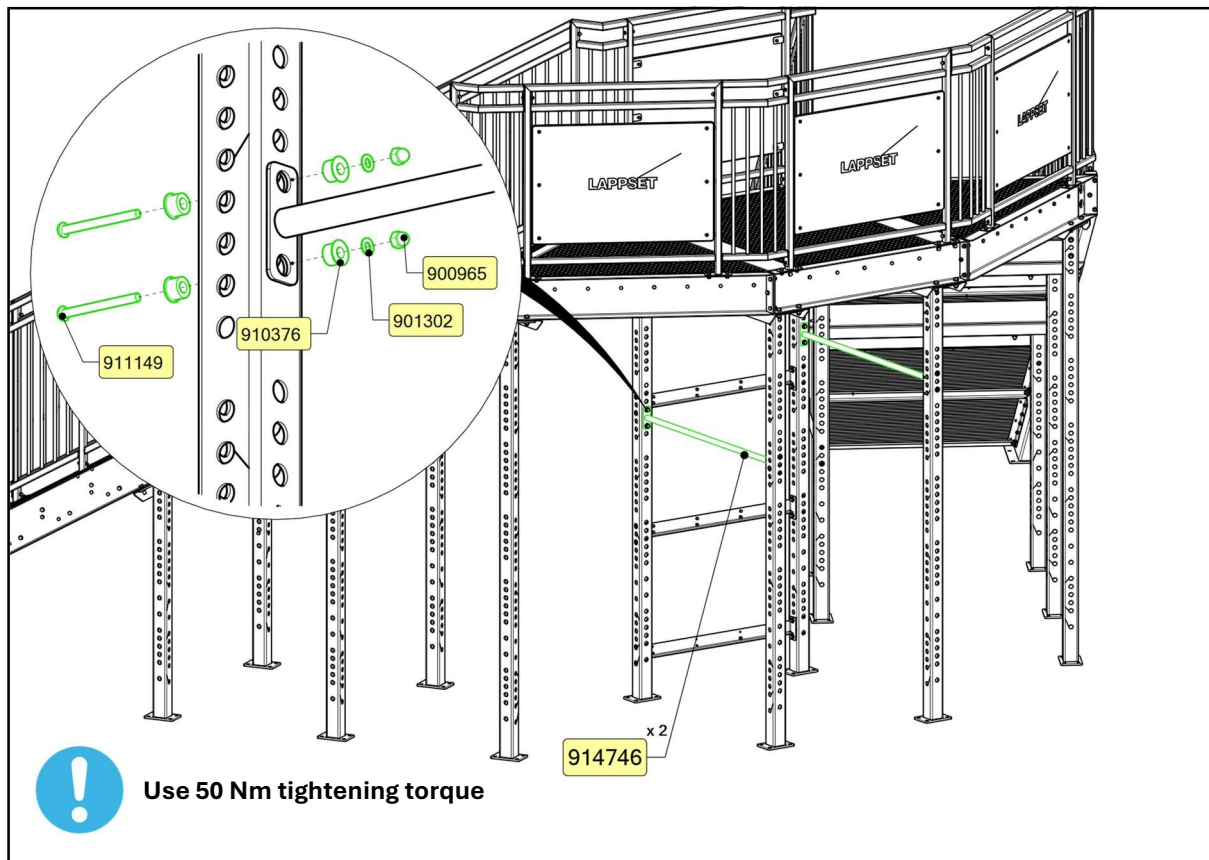

## SISU FITNESS STAIRS

### BARS-3 (1 PC)

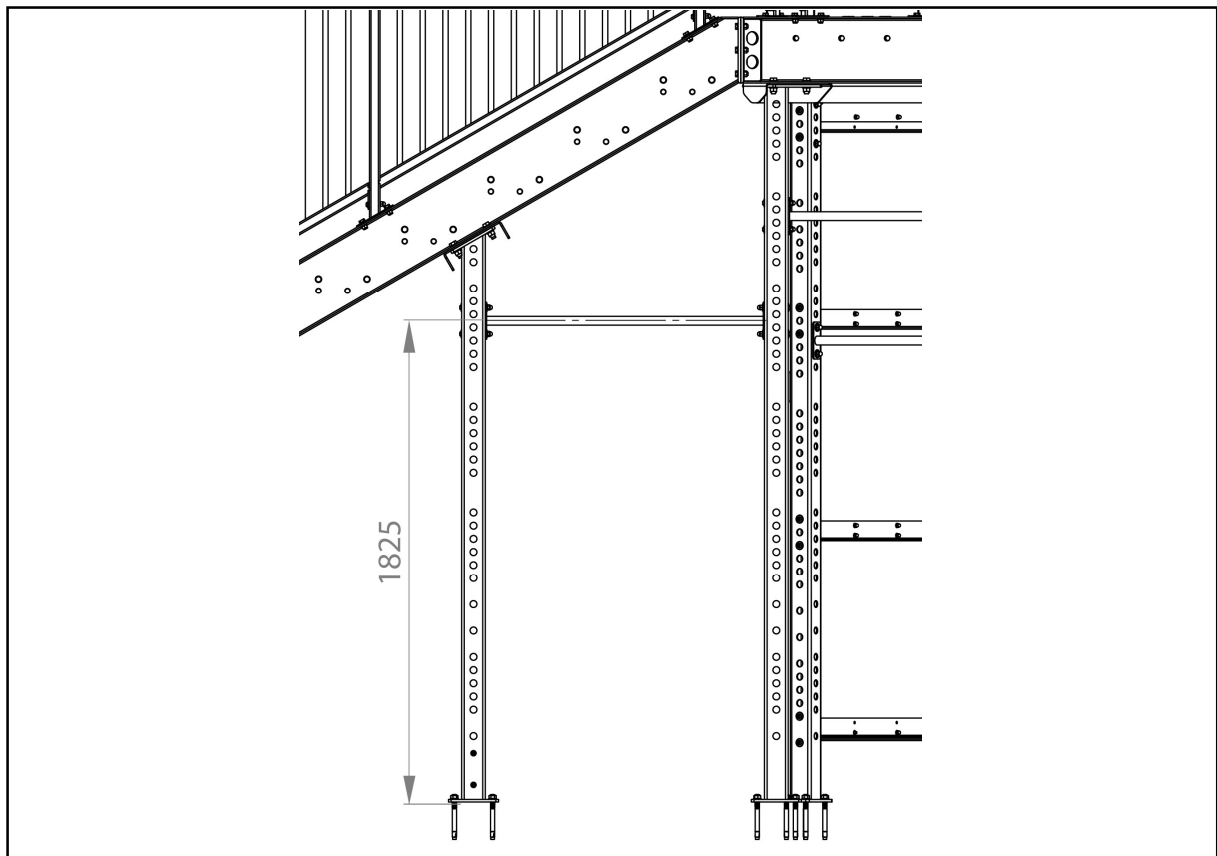
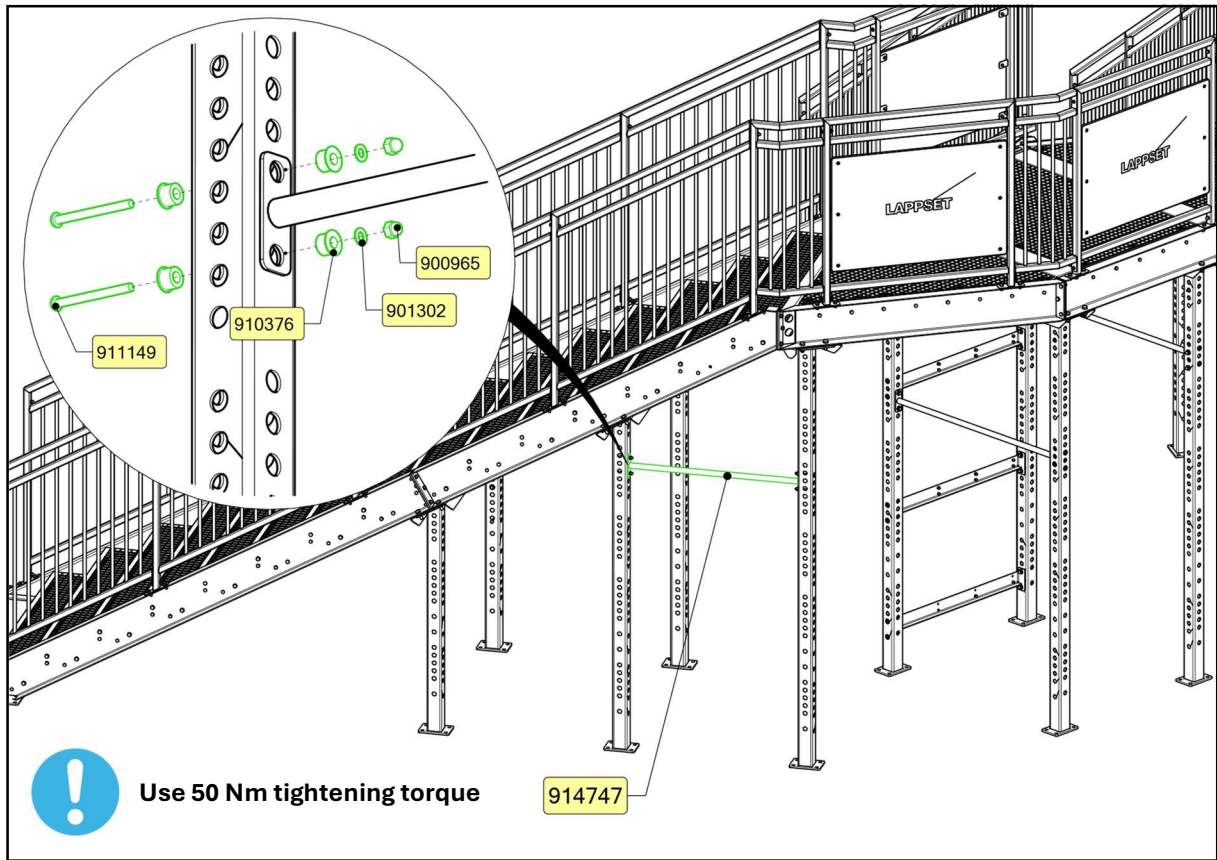

## SISU FITNESS STAIRS

### BARS-4 (8 PCS)

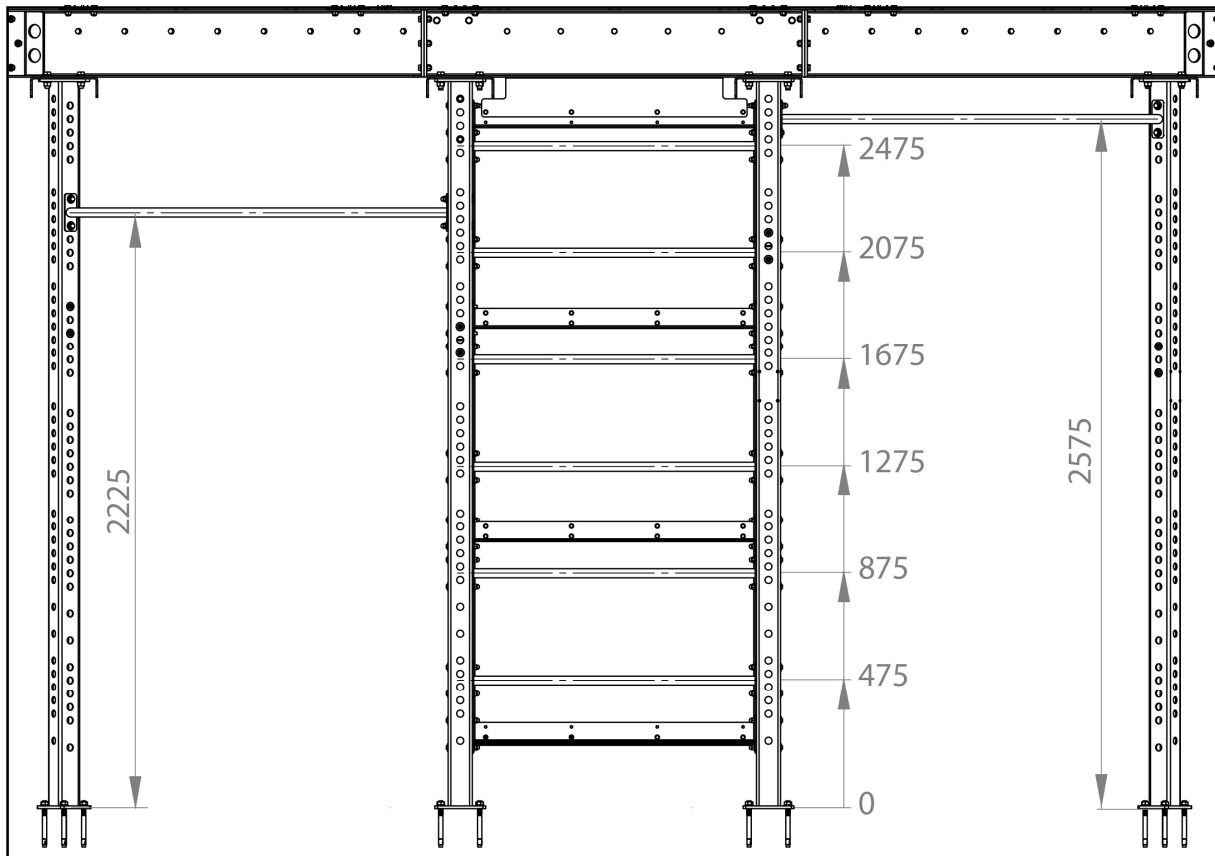
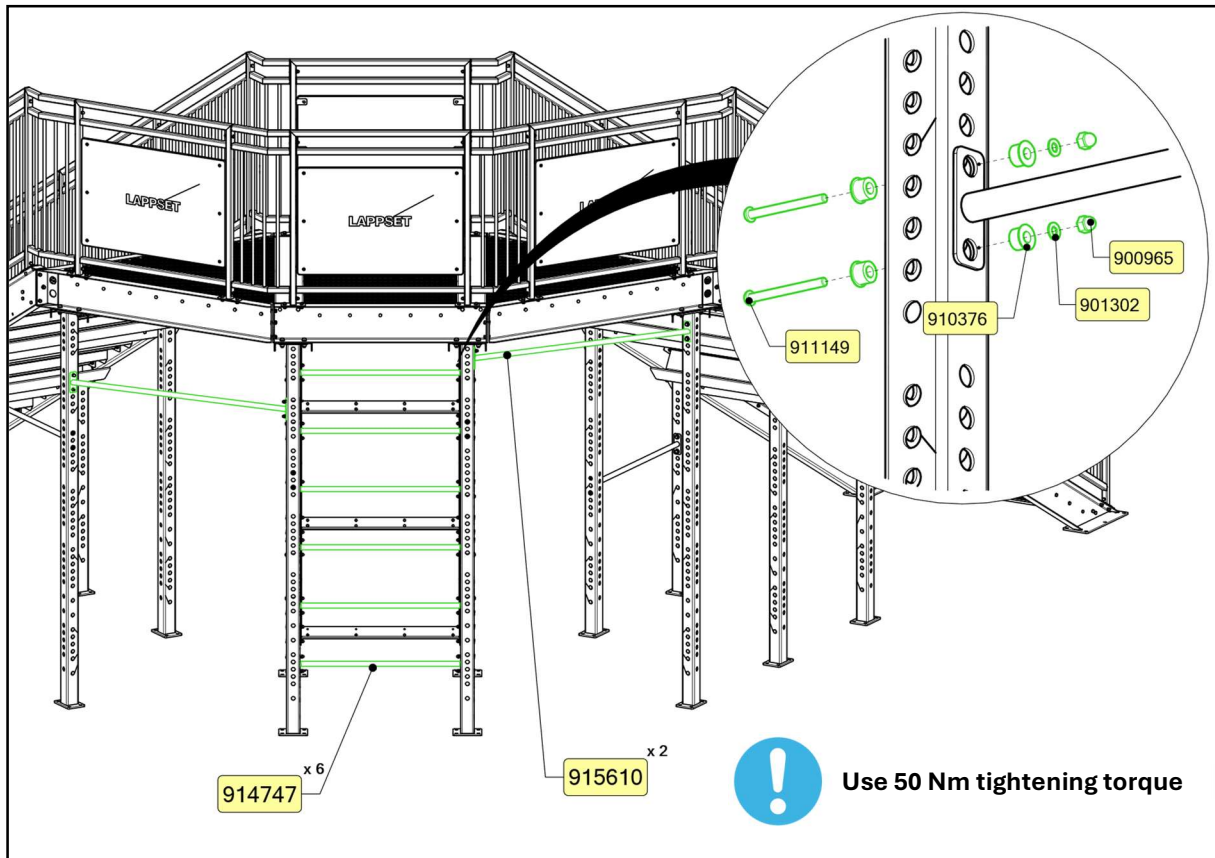

## SISU FITNESS STAIRS

### BARS-5 (2 PCS)

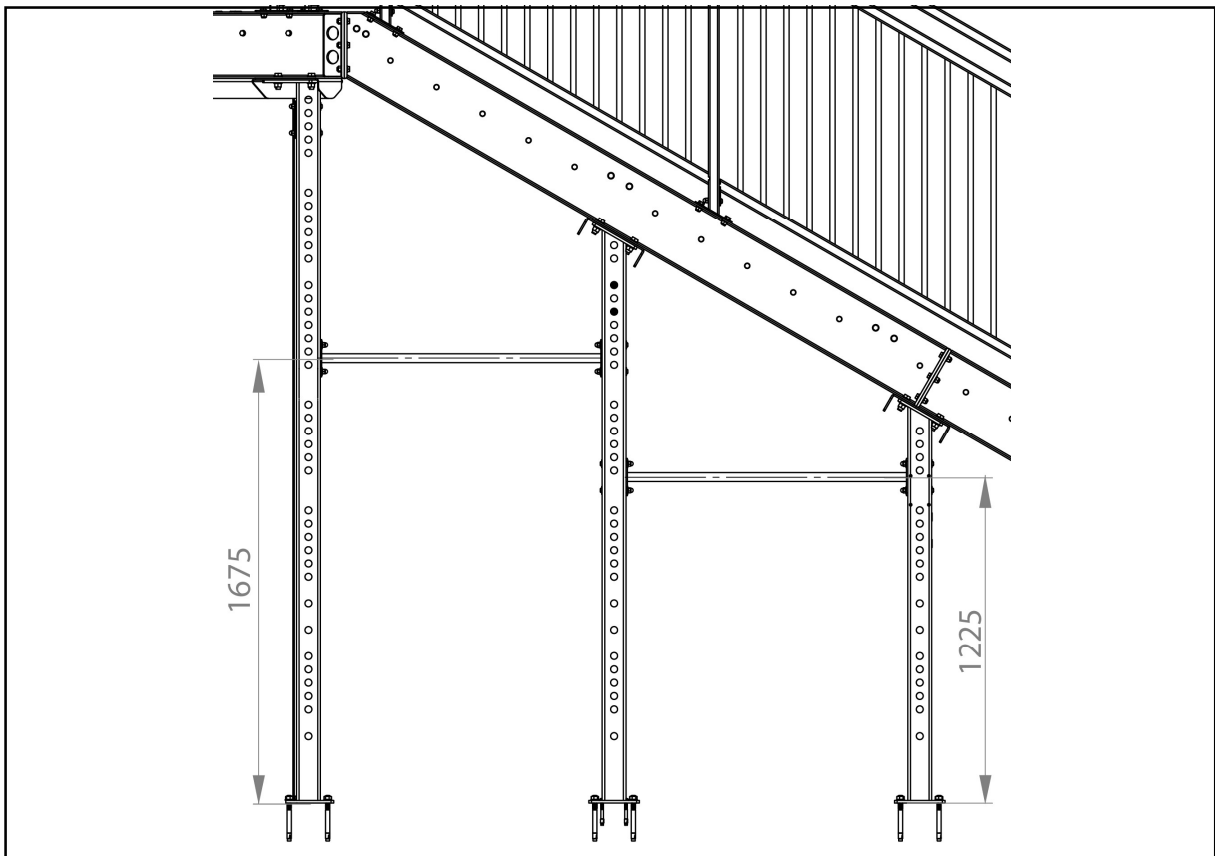
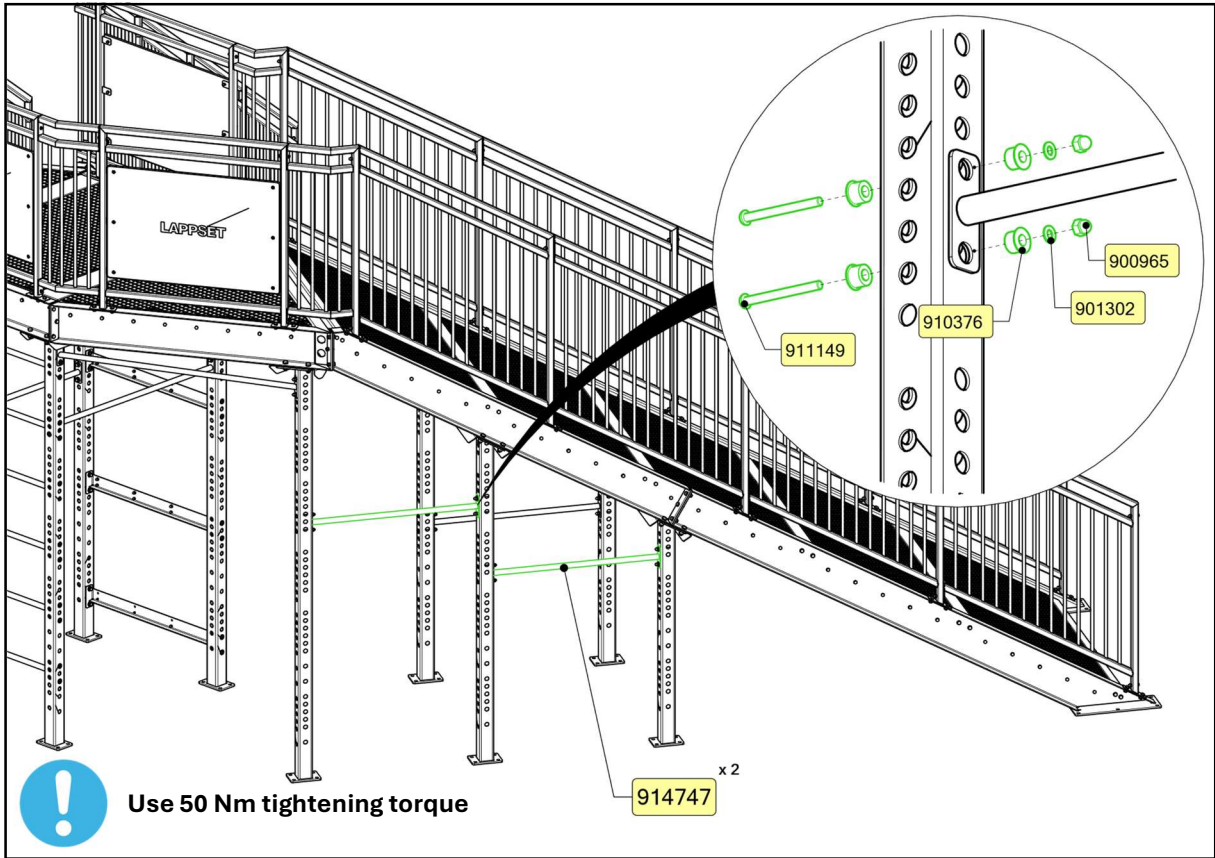

## SISU FITNESS STAIRS

### ROPE RINGS (6 PCS)

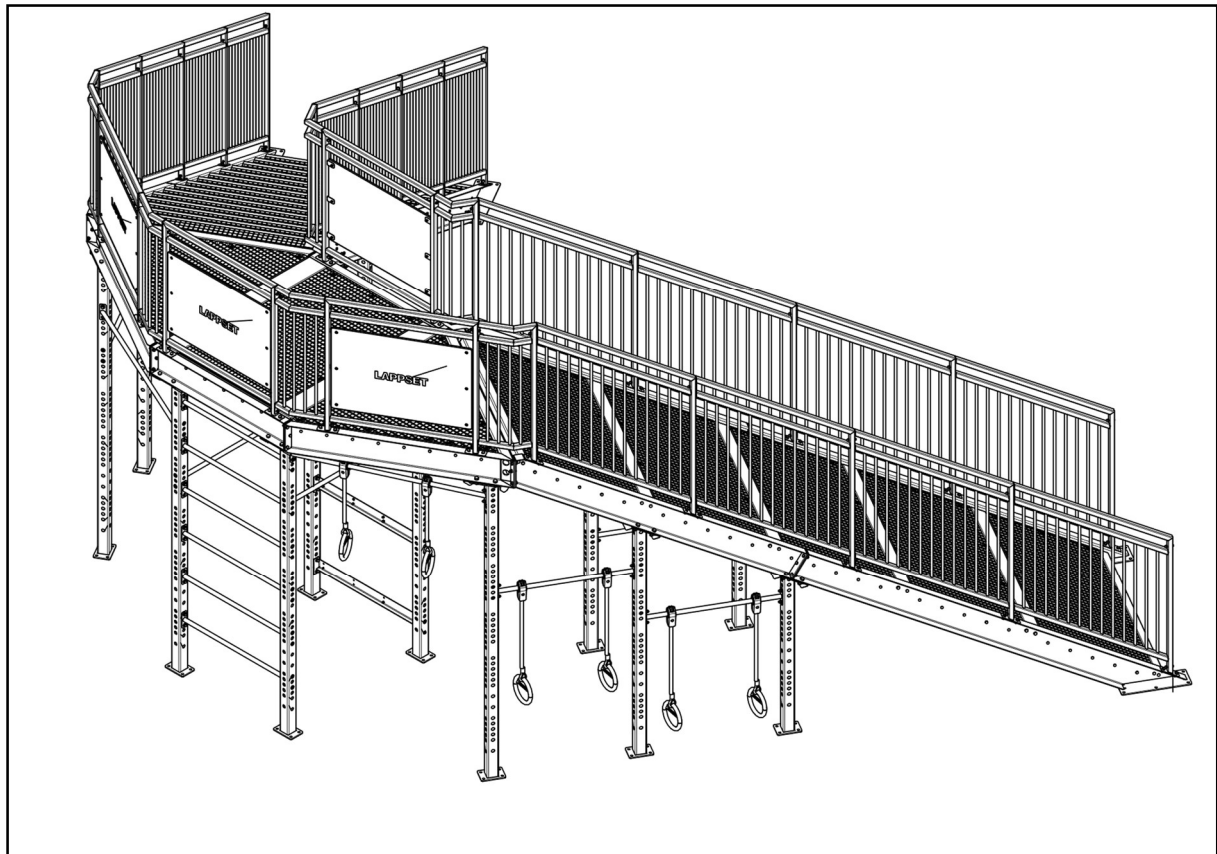
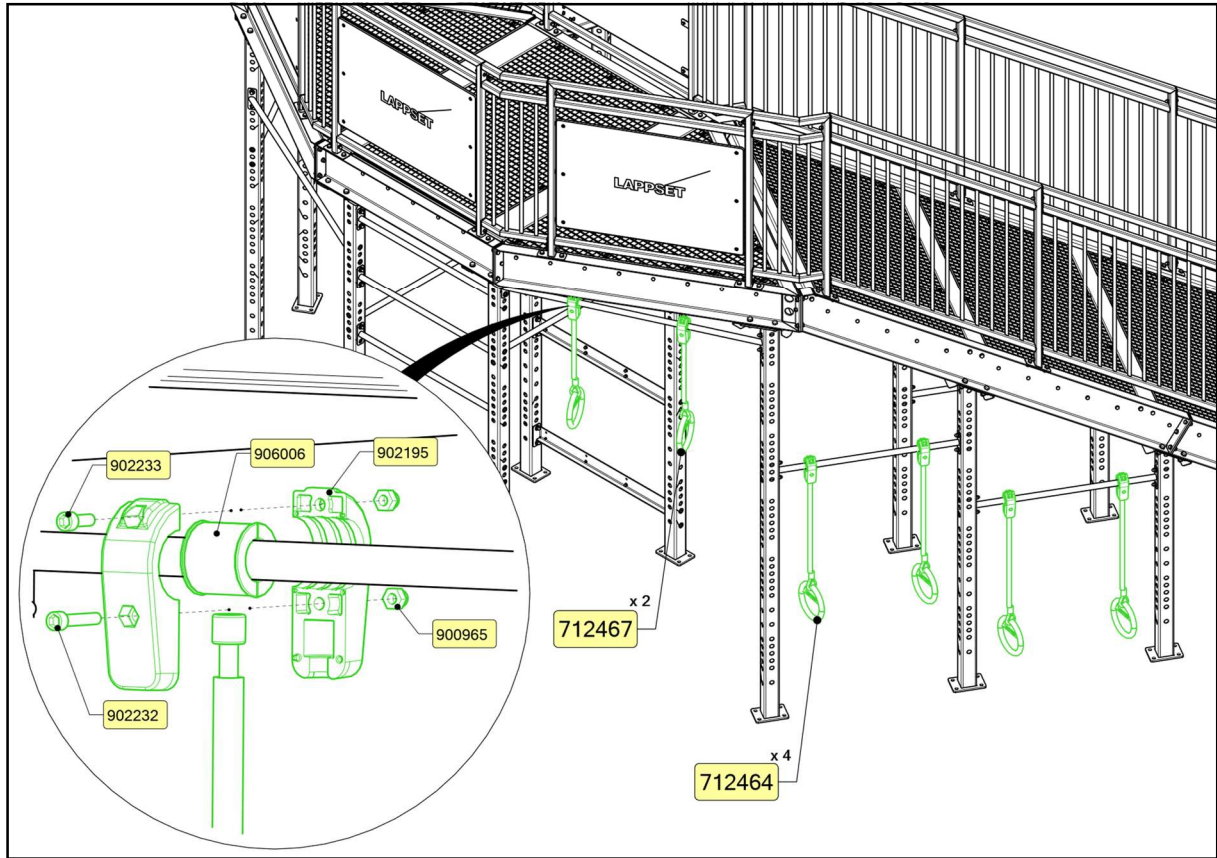

## SISU FITNESS STAIRS

### ANCHORS (80 PCS)

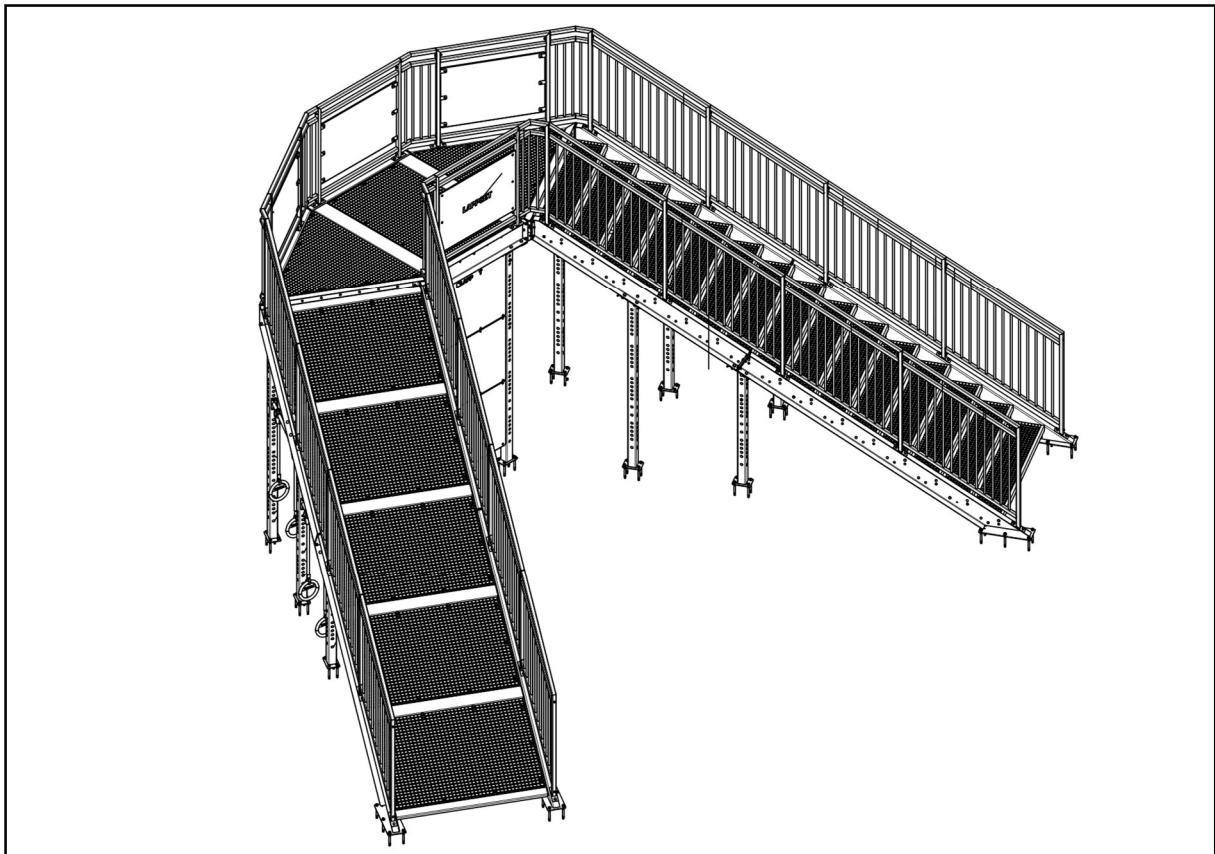
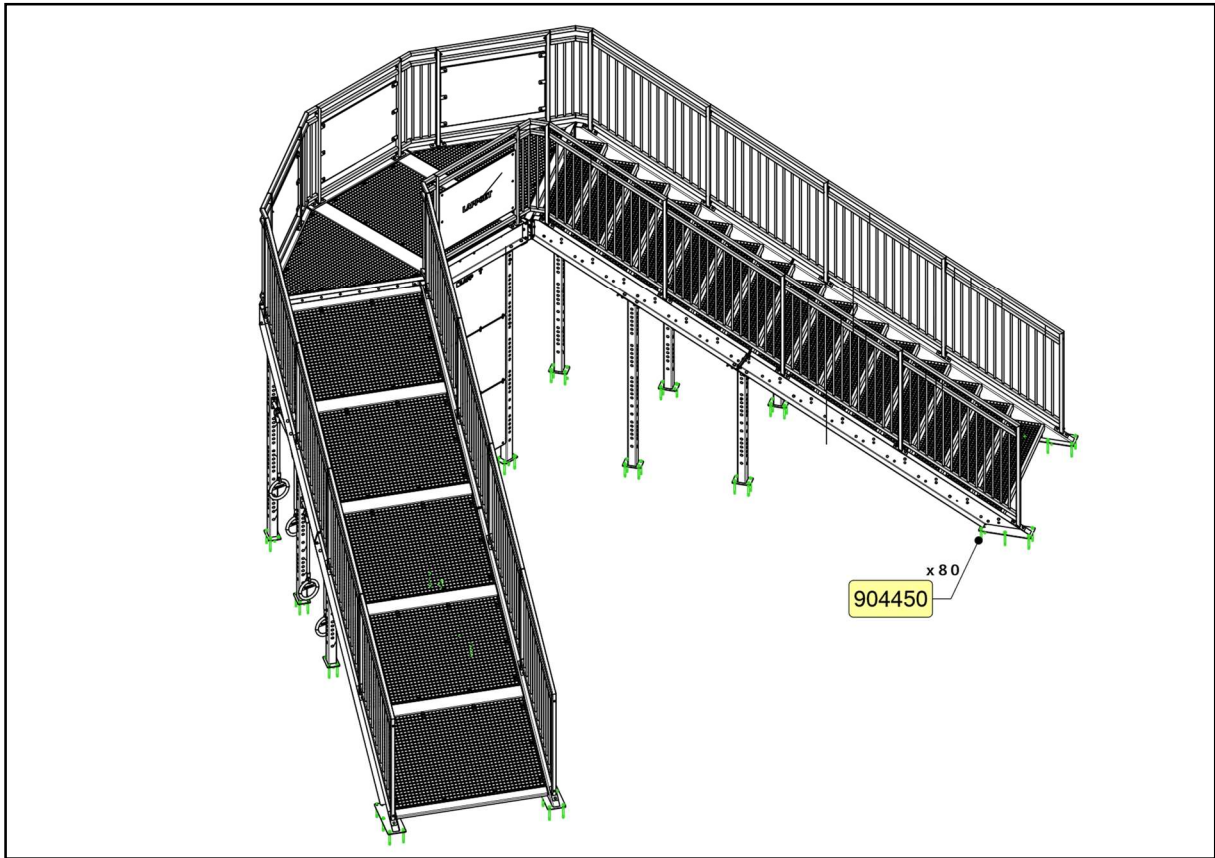

## SISU FITNESS STAIRS

### VERTICAL BAR AND DIP

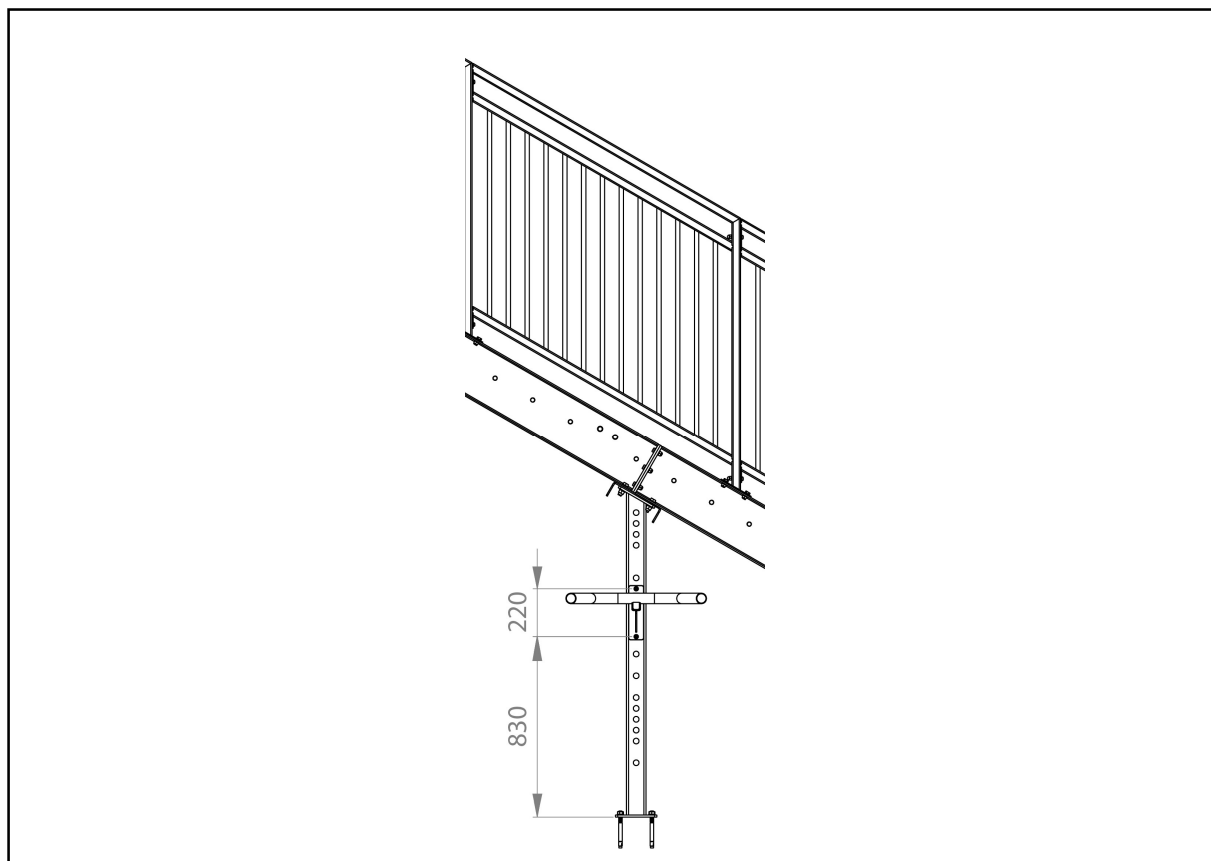
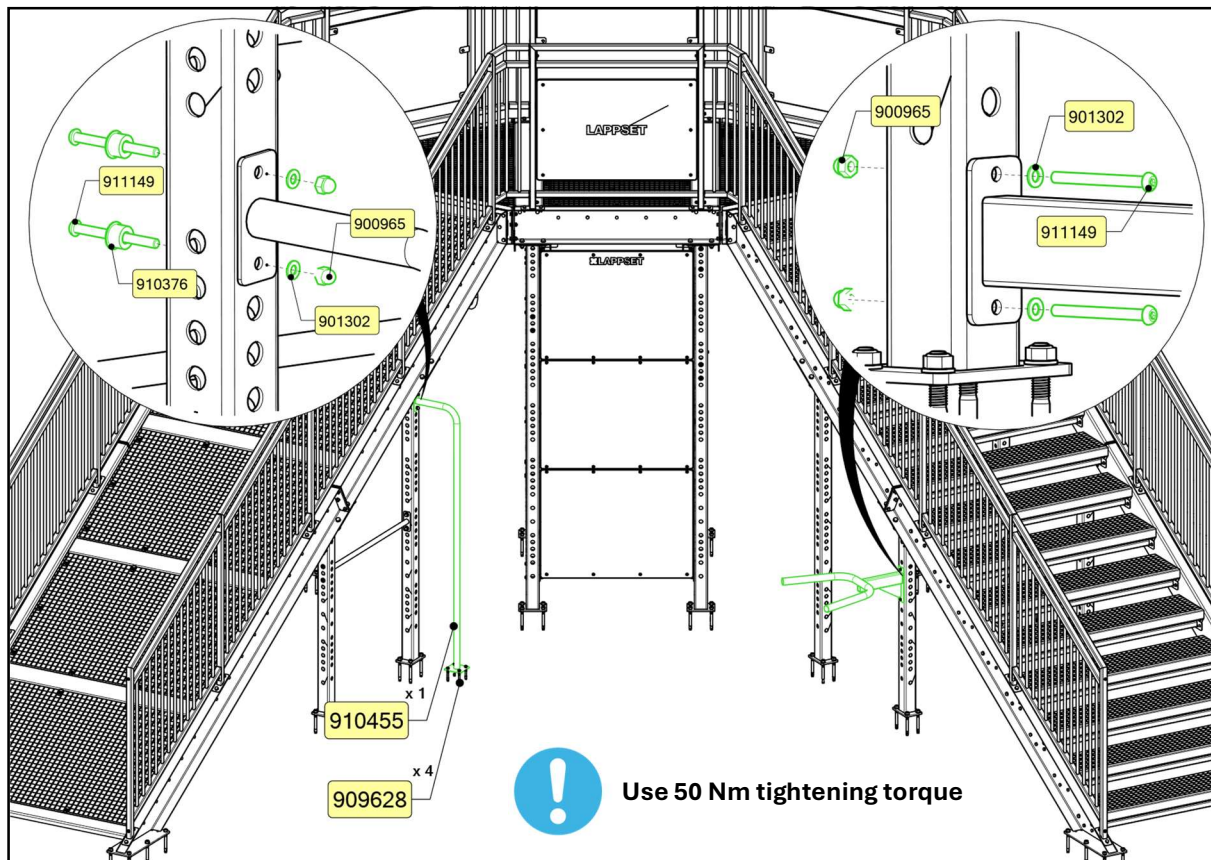

## SISU FITNESS STAIRS

### VERTICAL BAR AND DIP

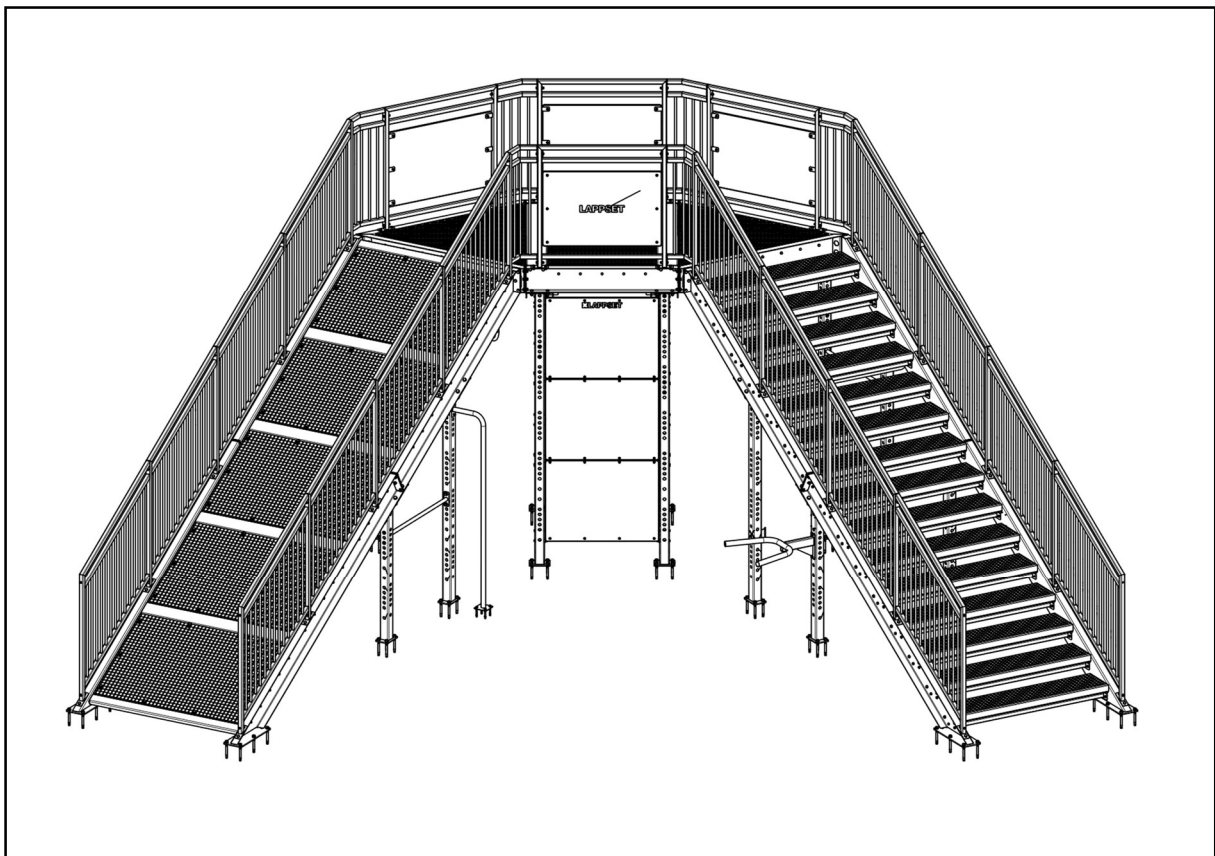
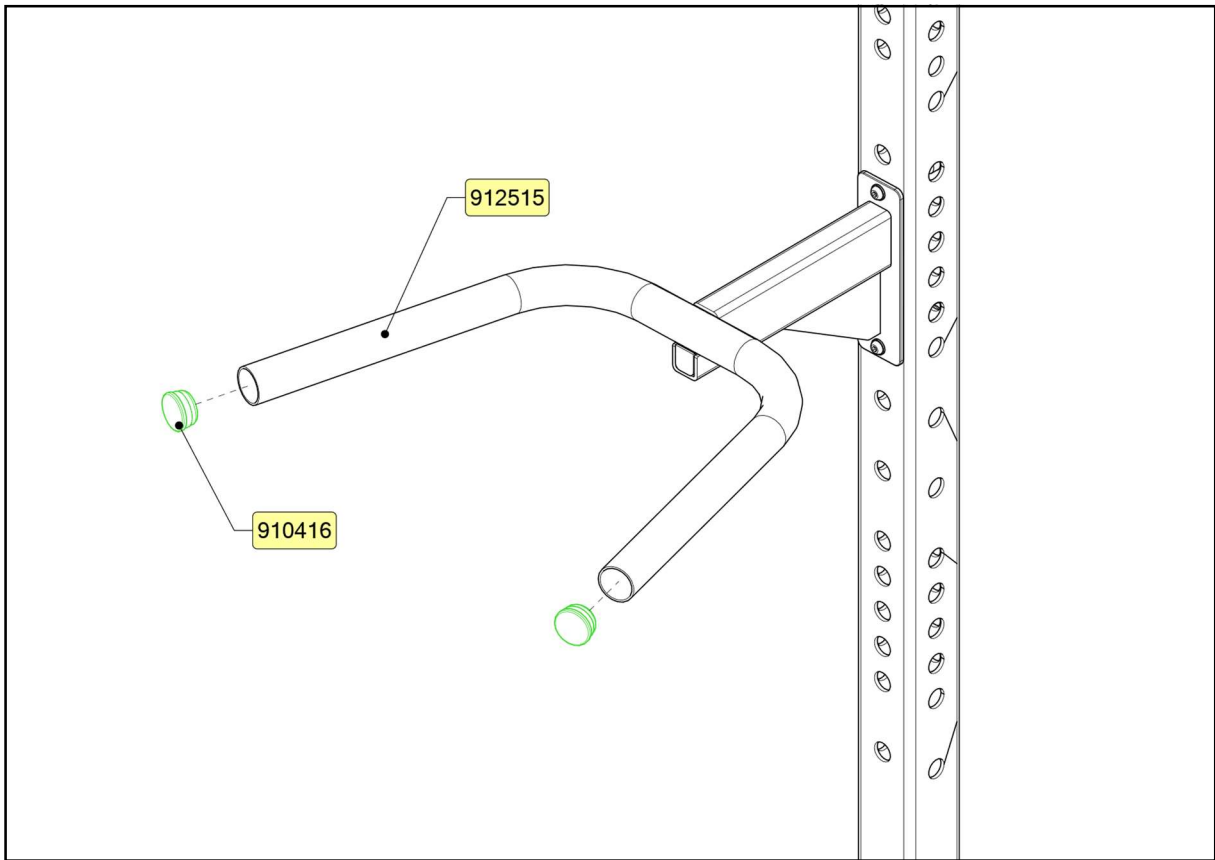

## SISU FITNESS STAIRS

### ABDOMINAL AND BACK MACHINE

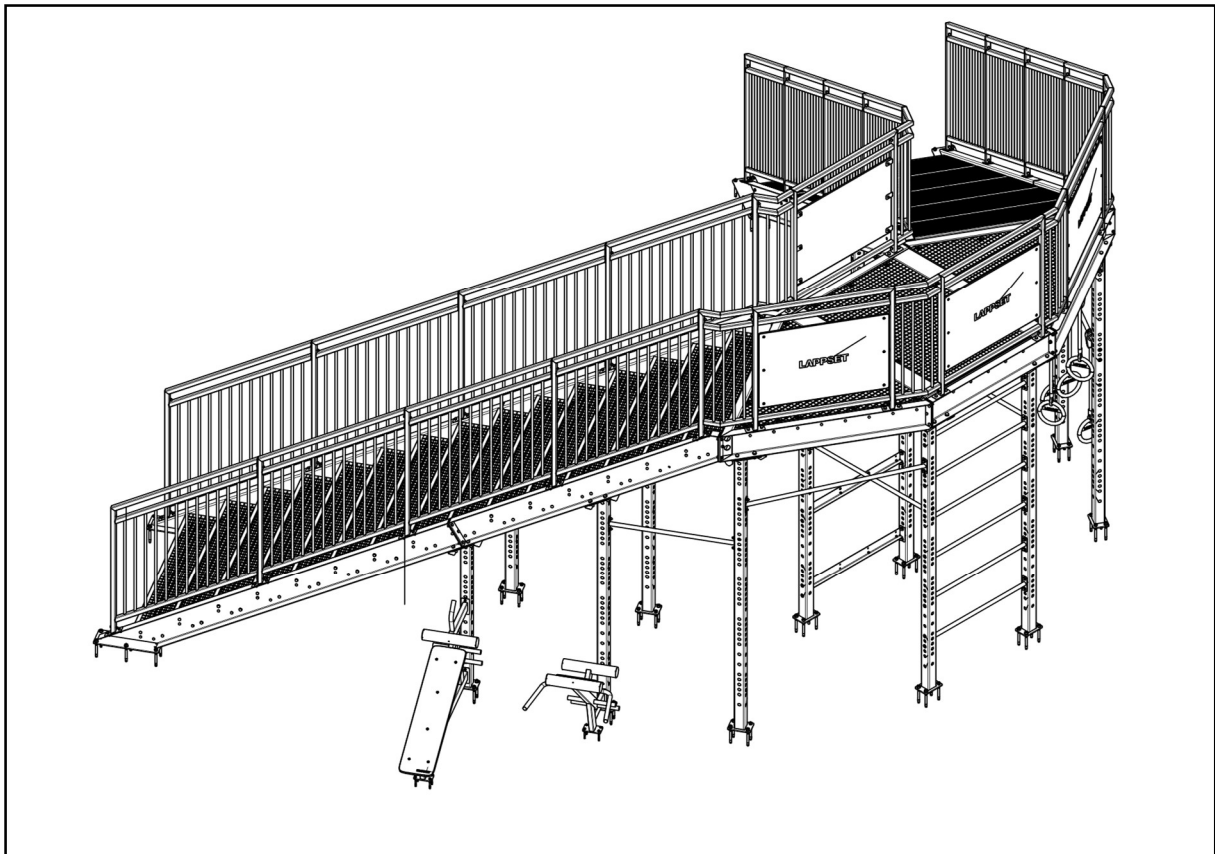
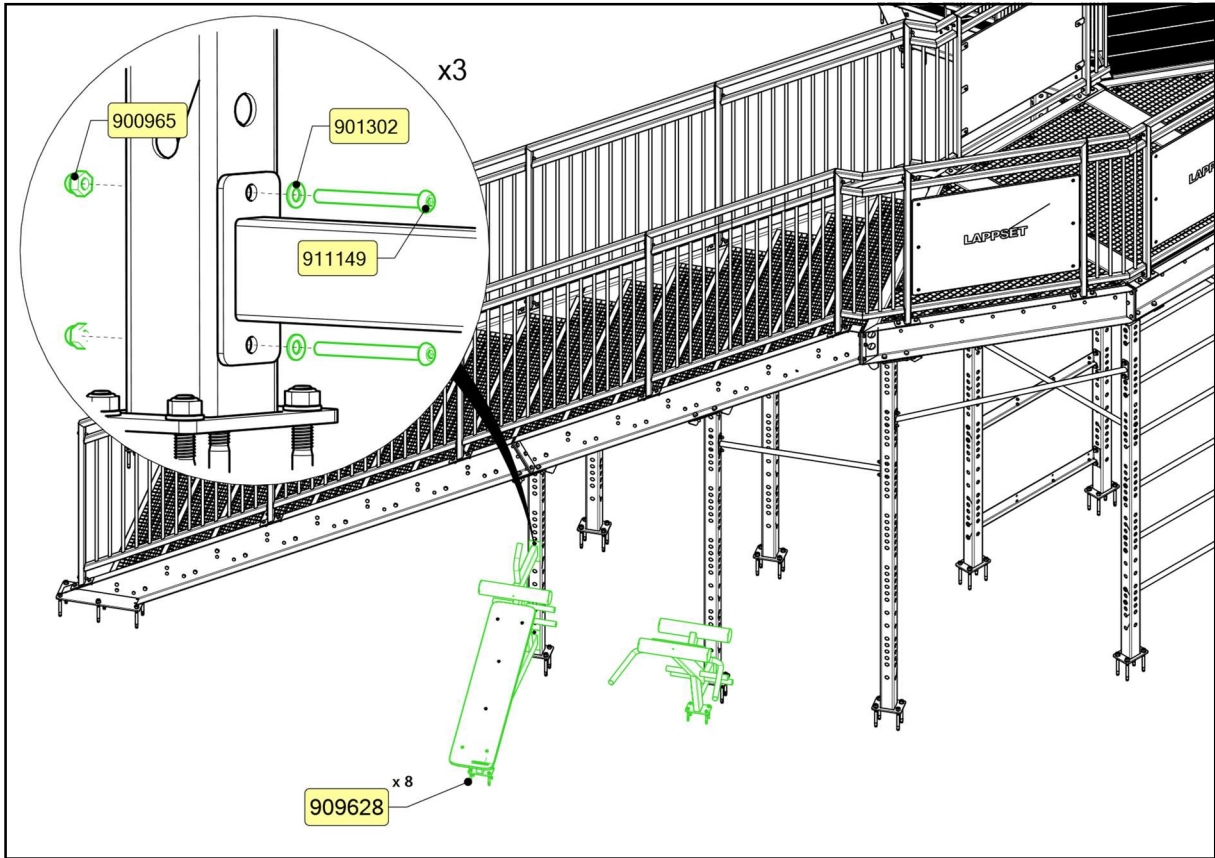

**SISU FITNESS STAIRS**

**STAIR MARKS**

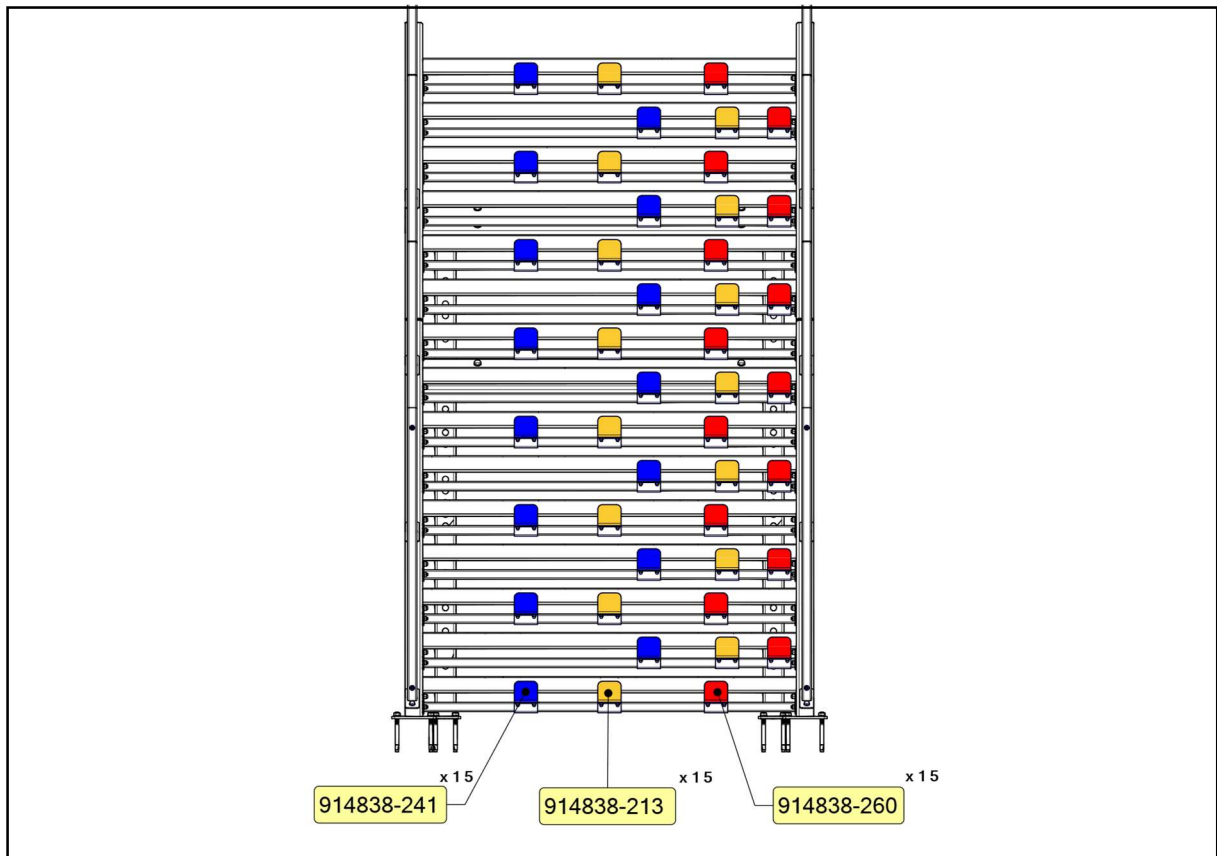
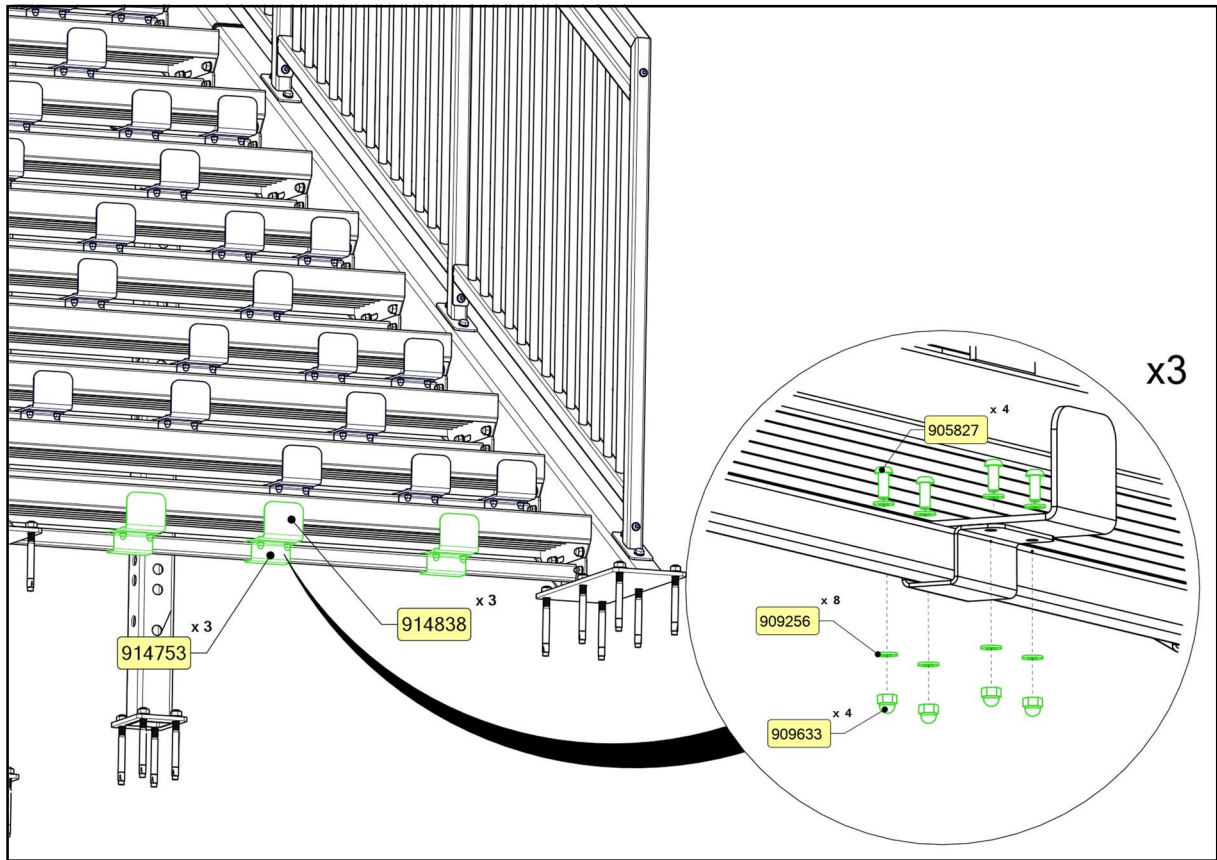

## SISU FITNESS STAIRS

### COUNTER

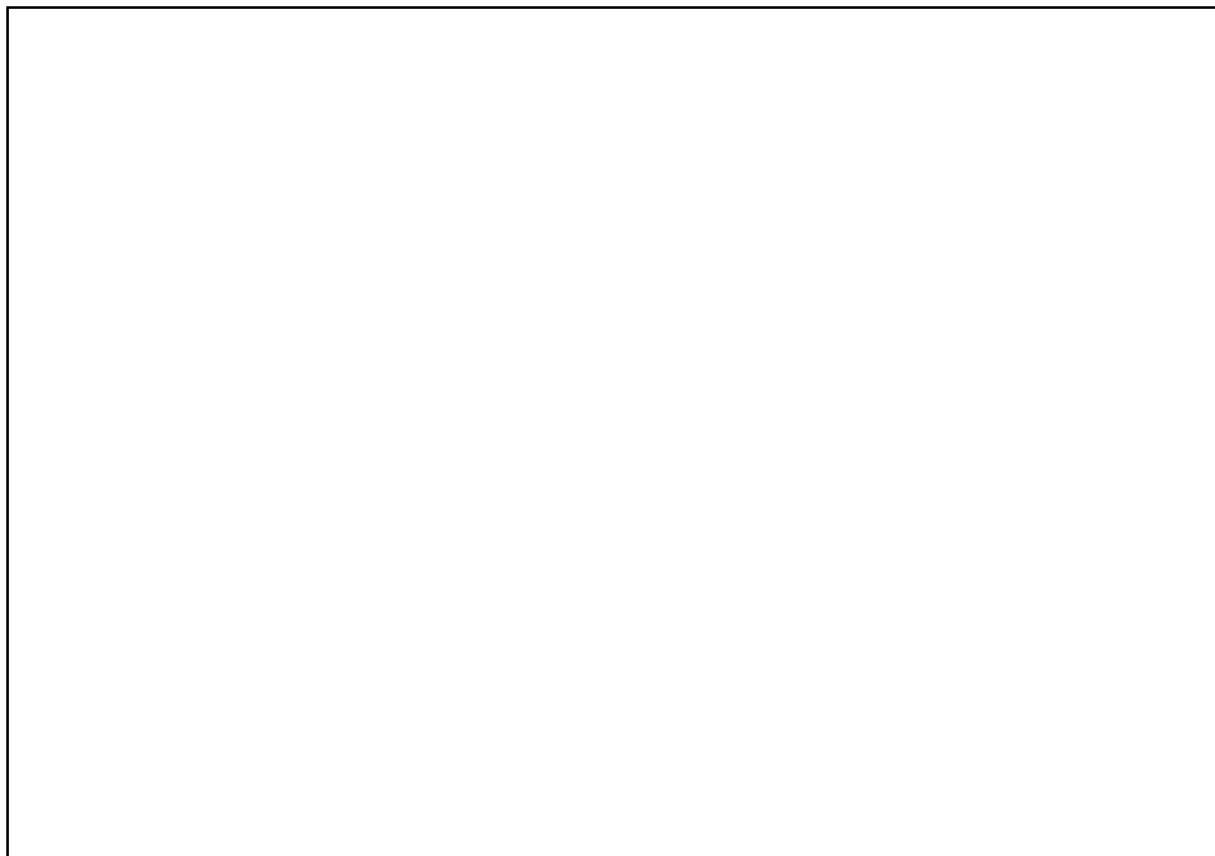
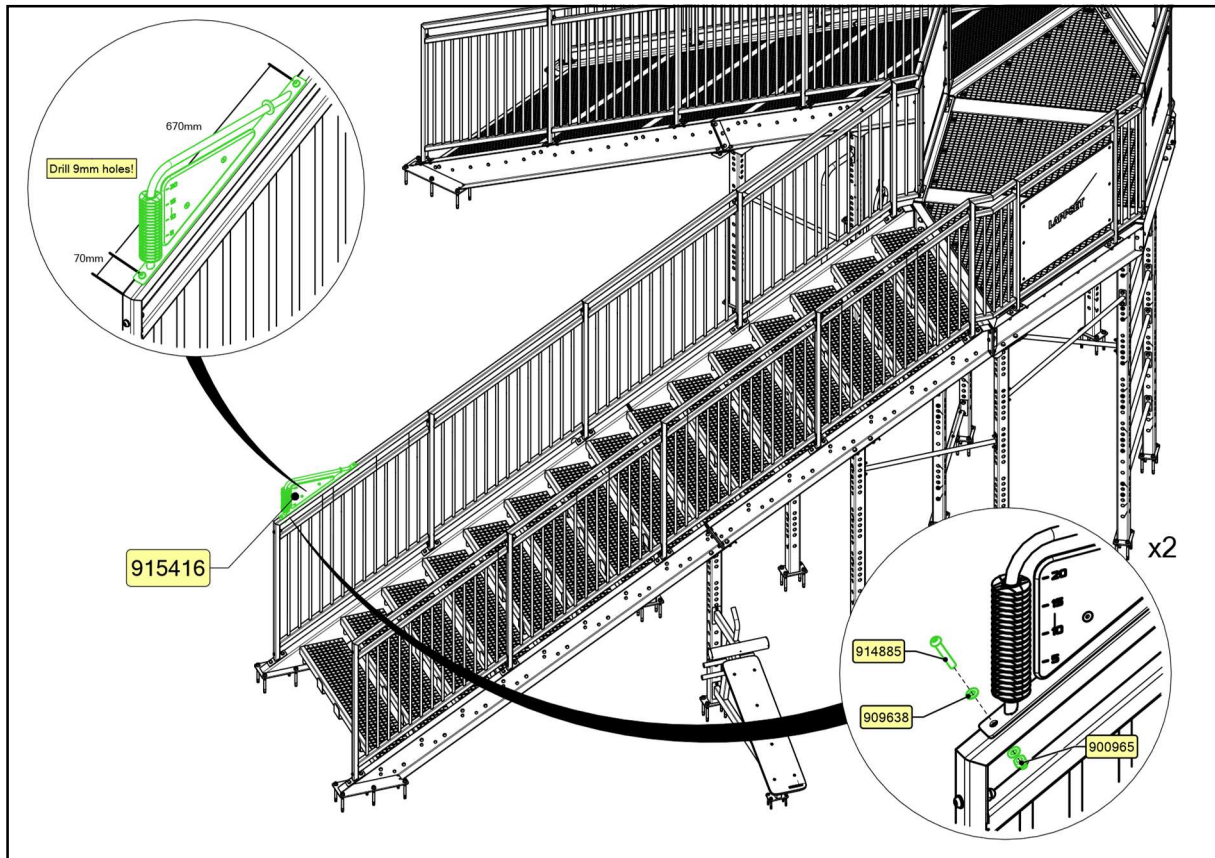

## SISU FITNESS STAIRS

### SIGNS

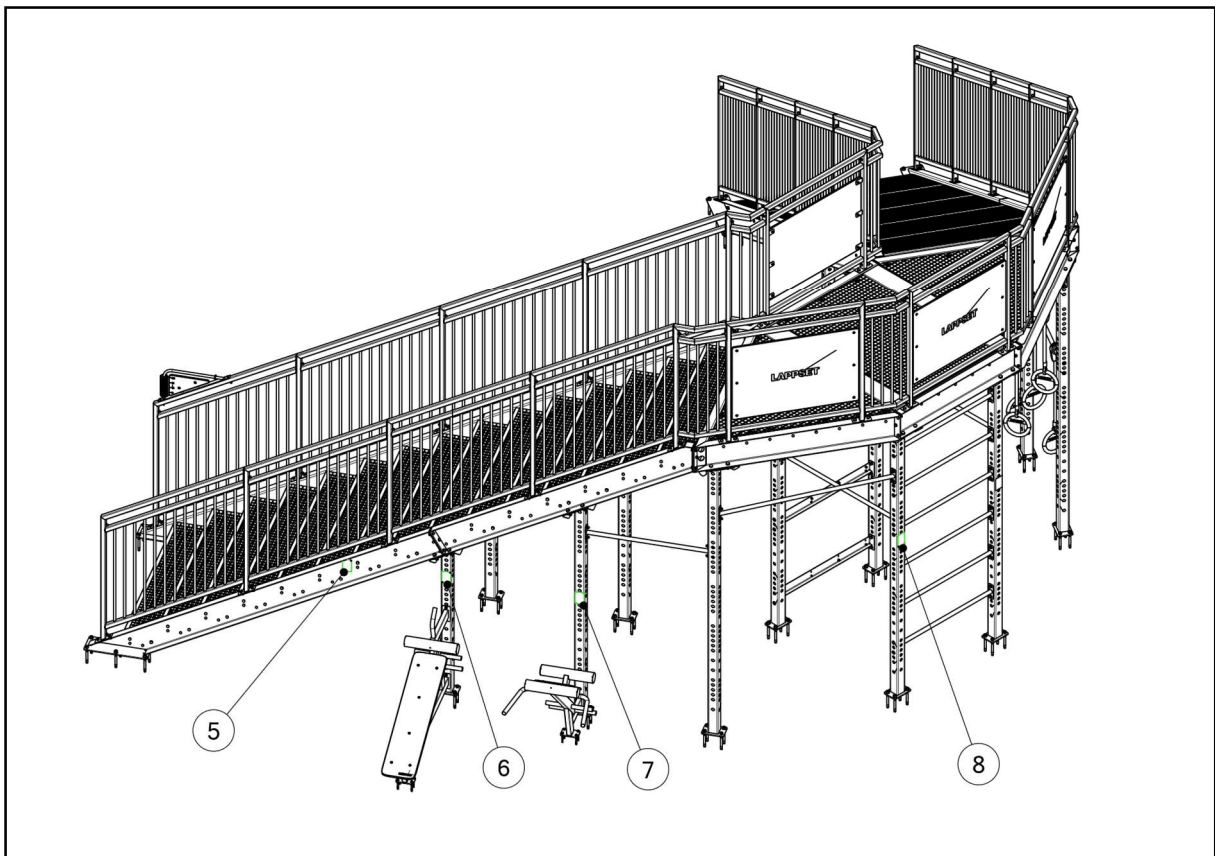
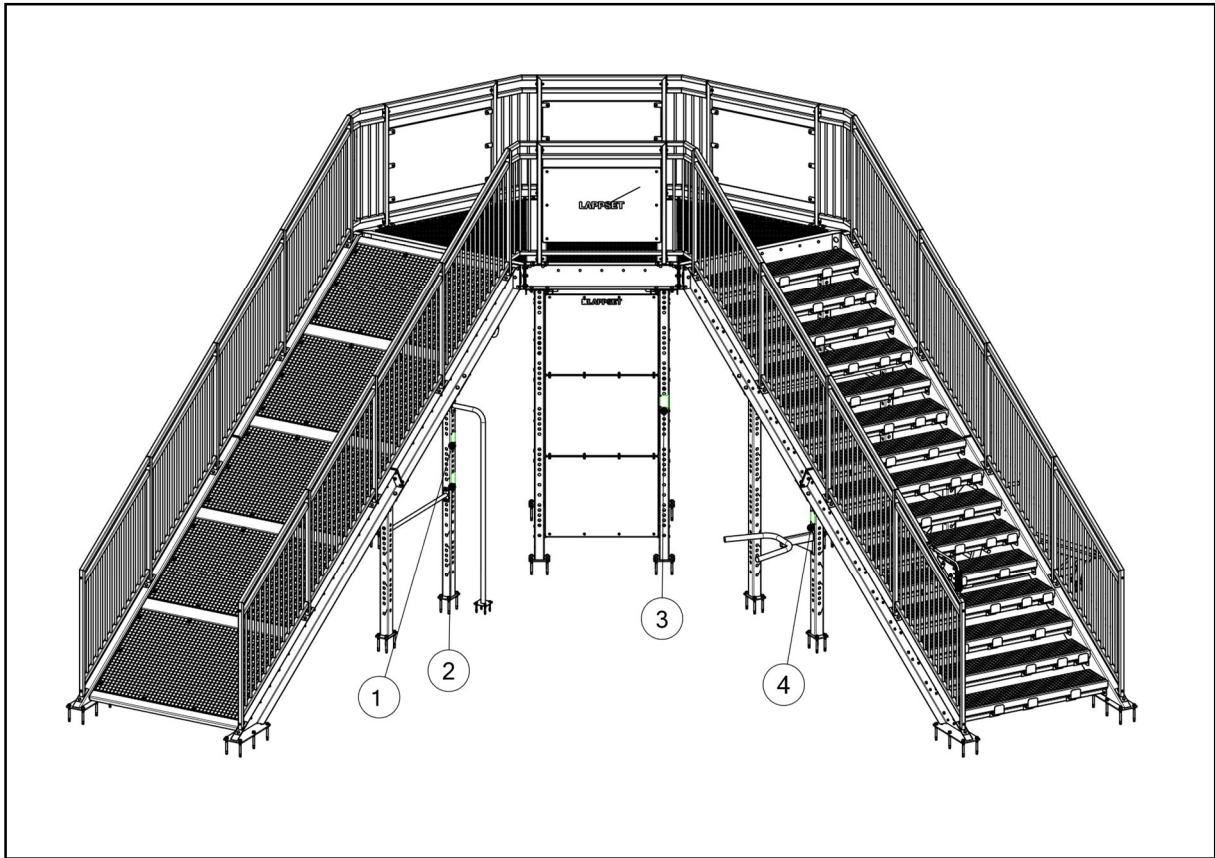

**SISU FITNESS STAIRS**

**SIGNS**

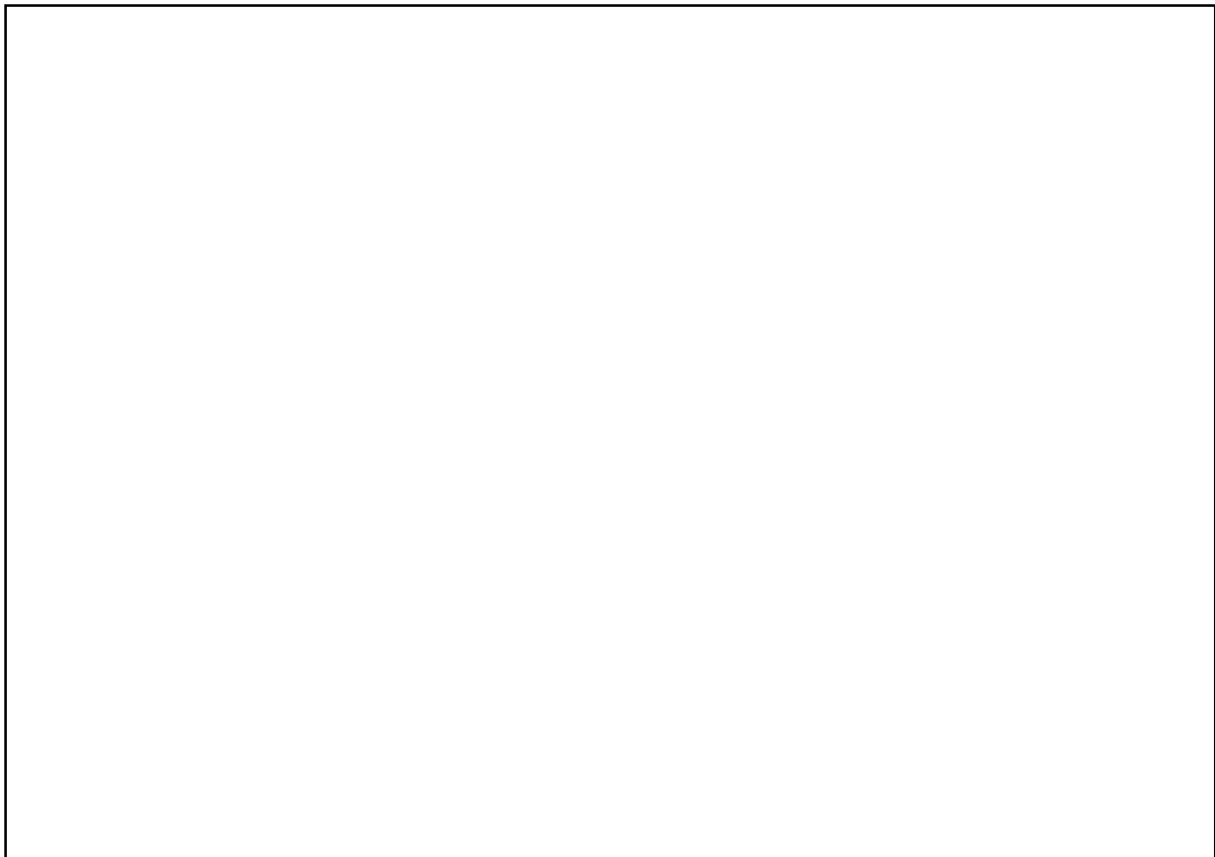
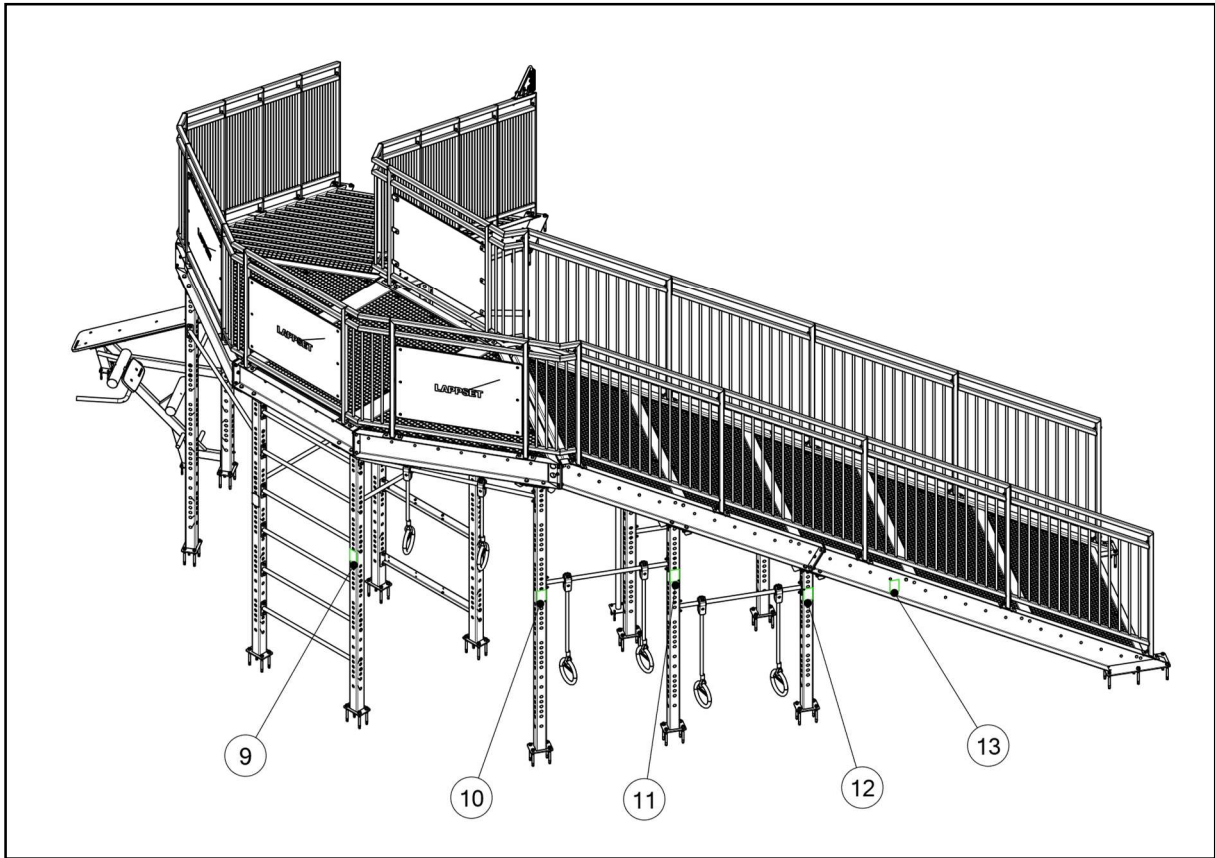

## SISU FITNESS STAIRS

### SIGN 1-2

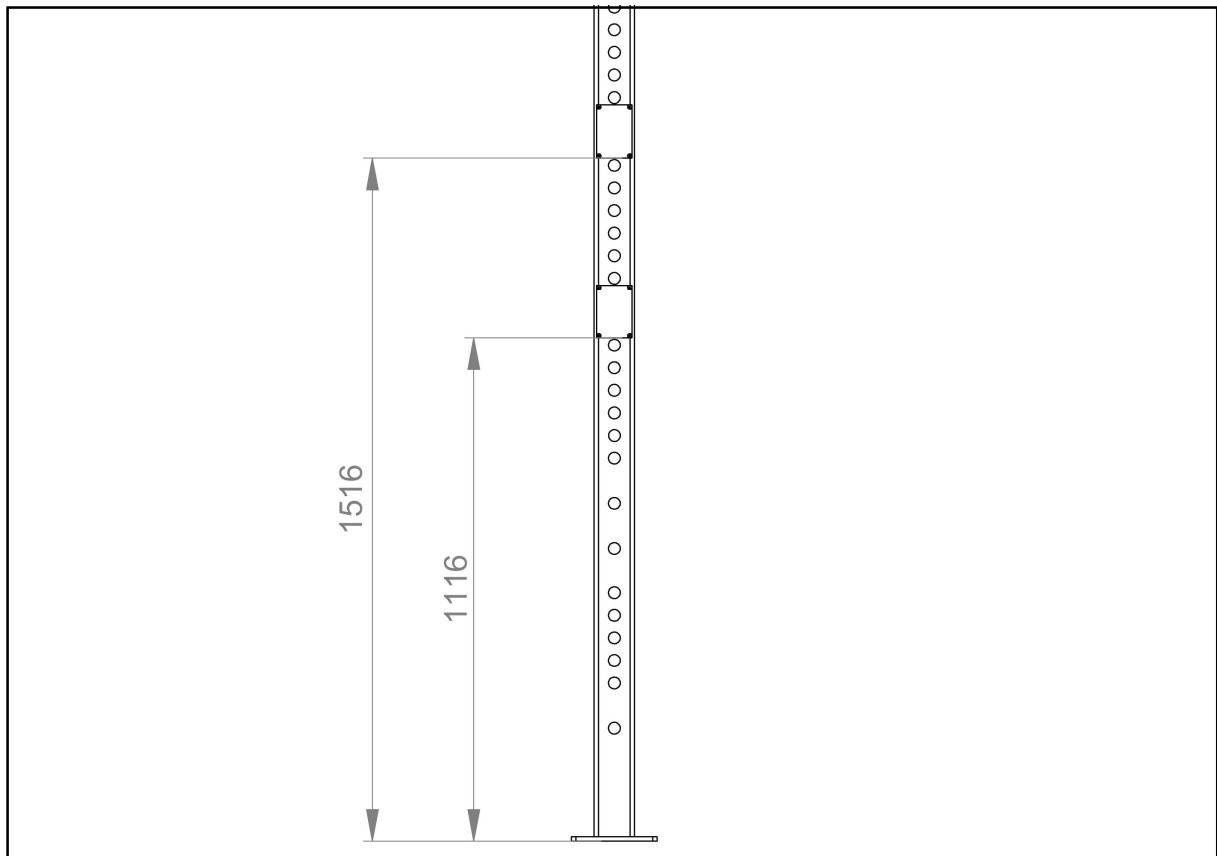
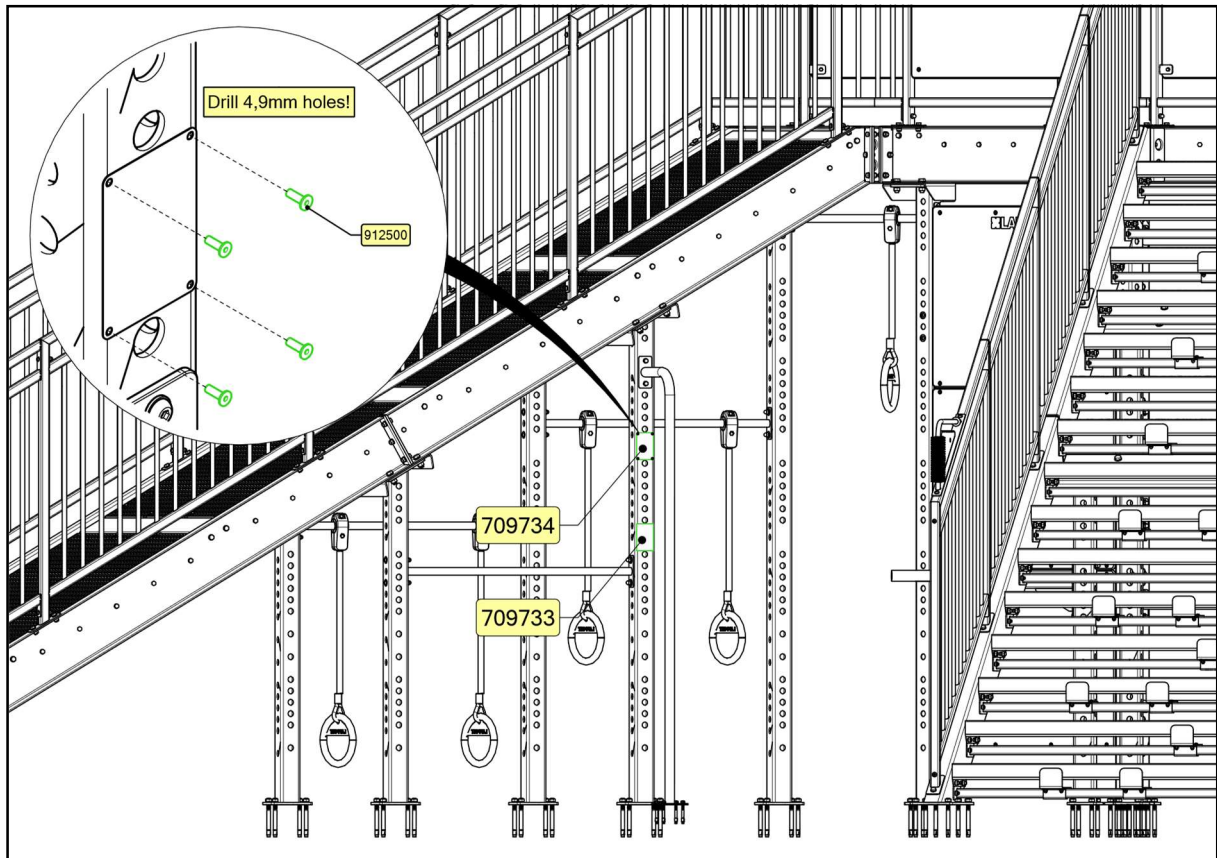

## SISU FITNESS STAIRS

### SIGN 3

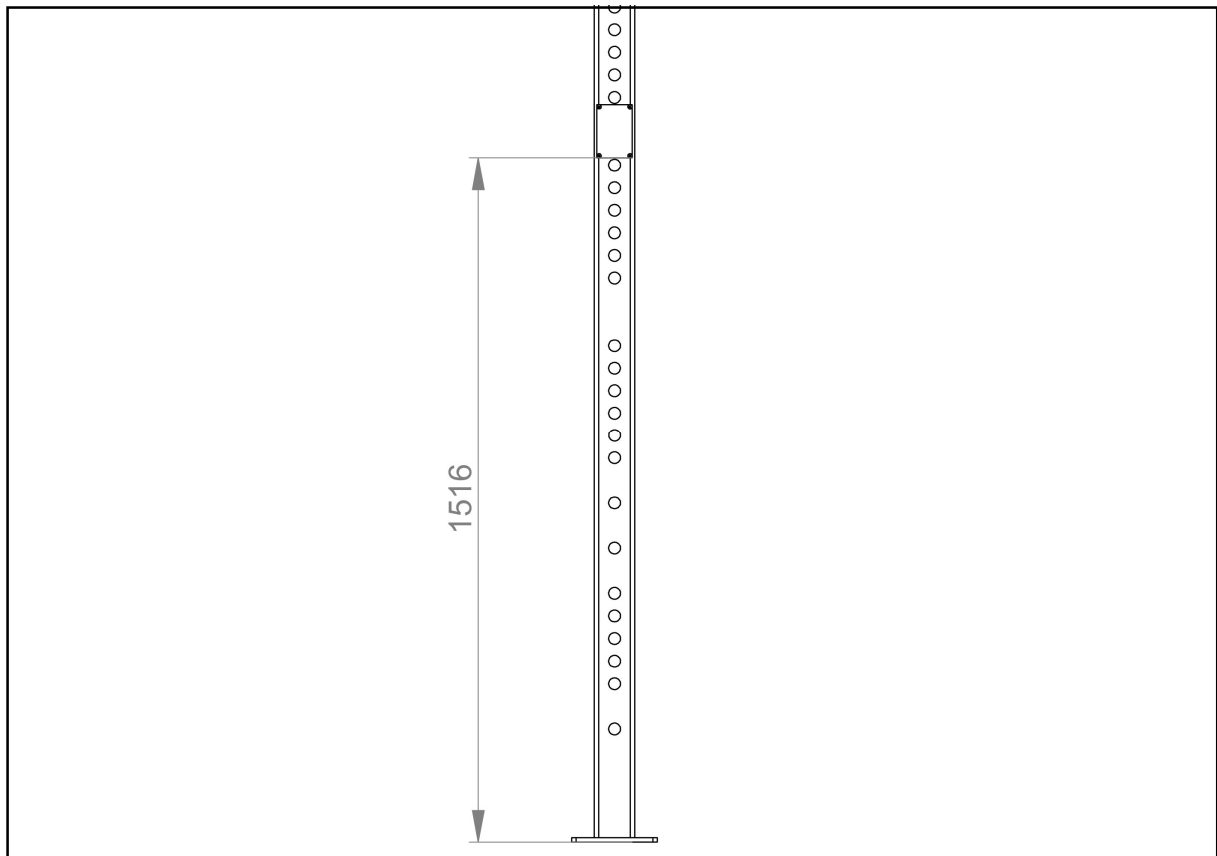
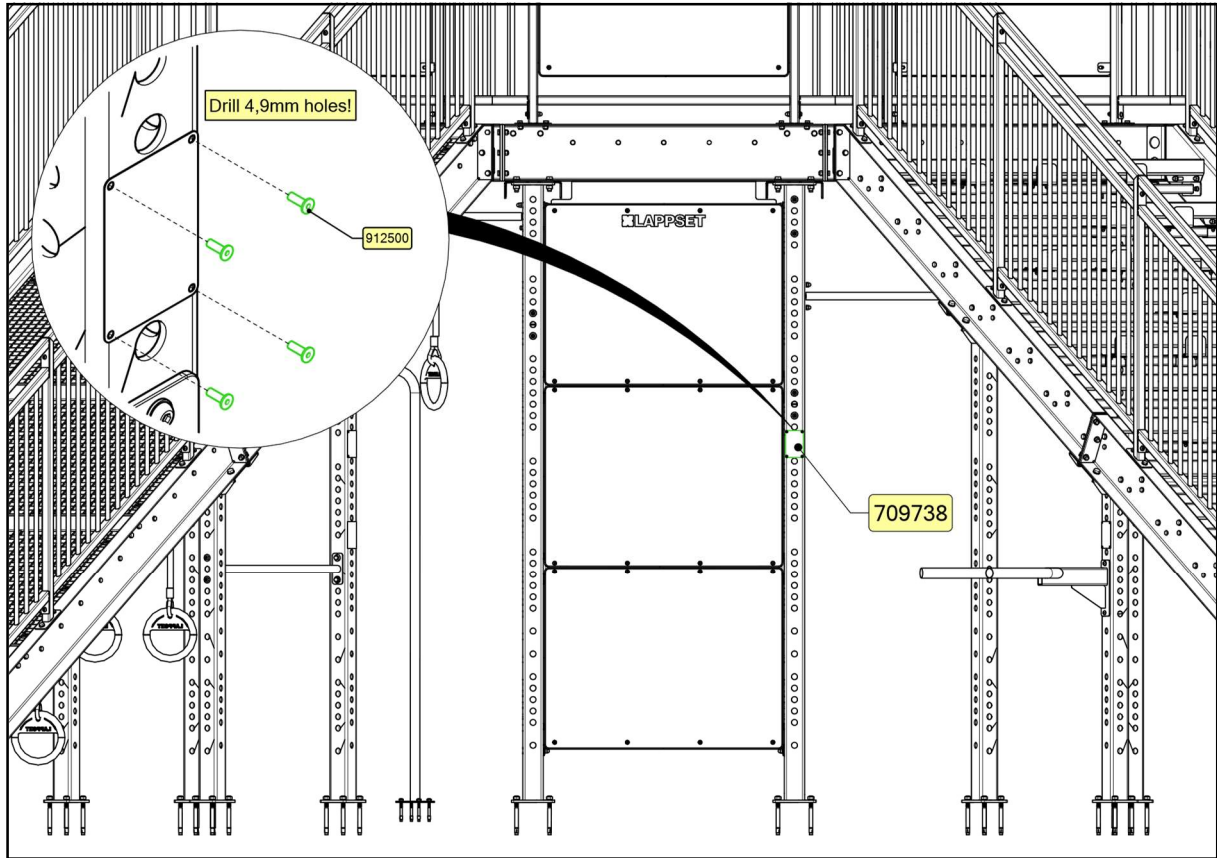

## SISU FITNESS STAIRS

### SIGN 4

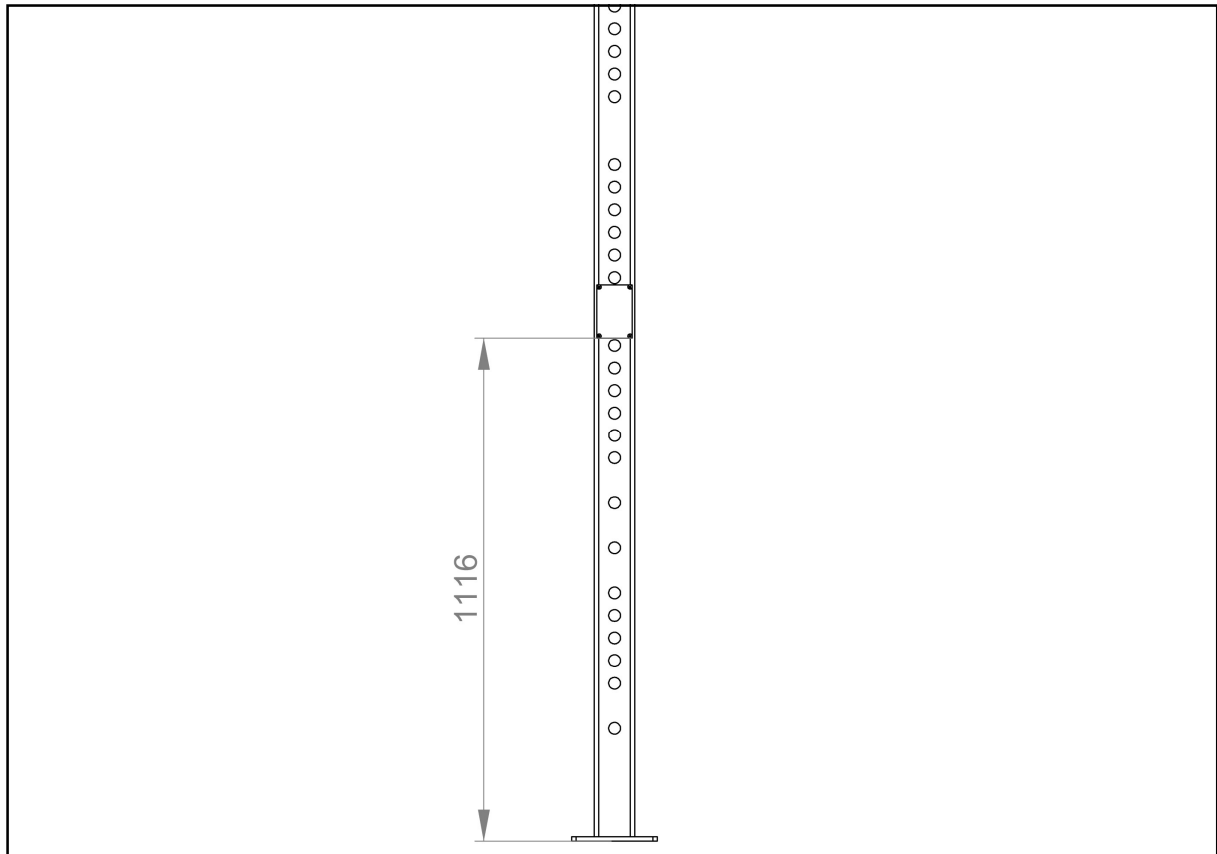
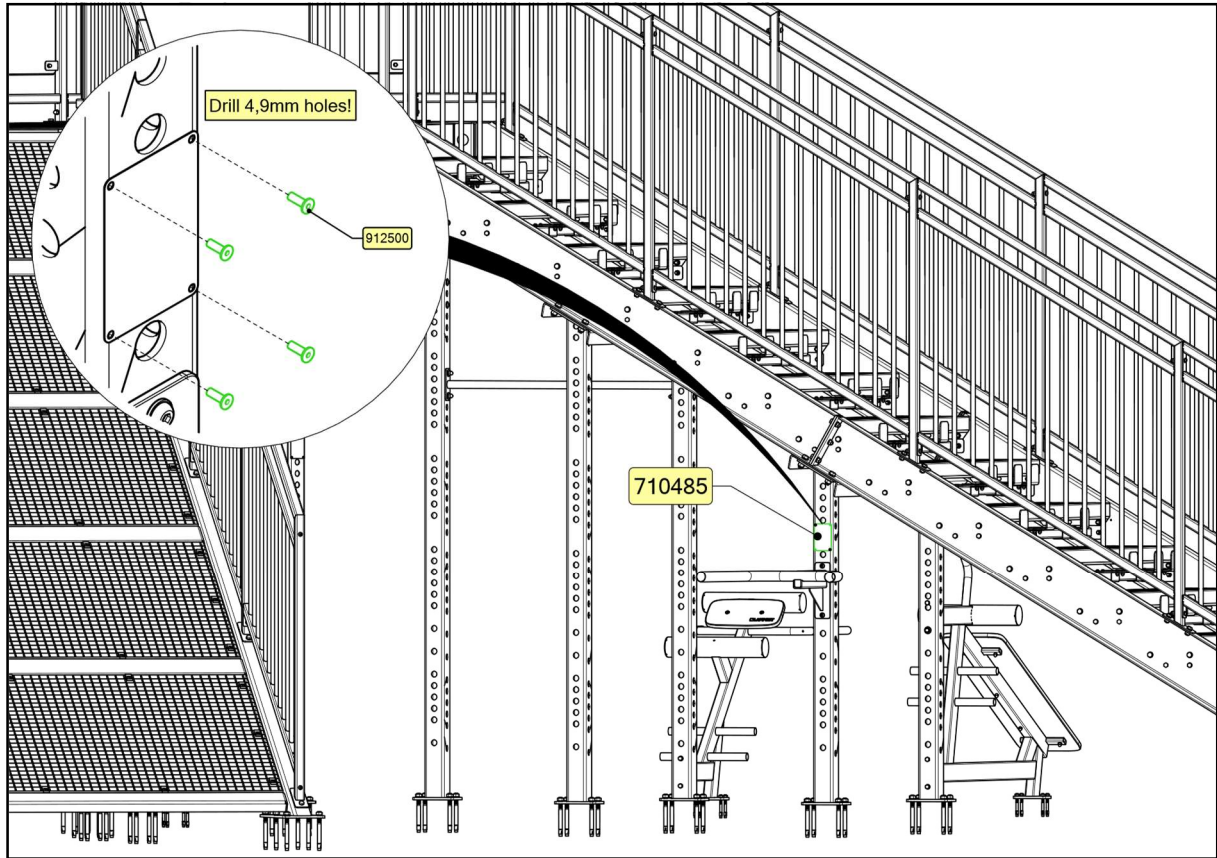

## SISU FITNESS STAIRS

### SIGN 5

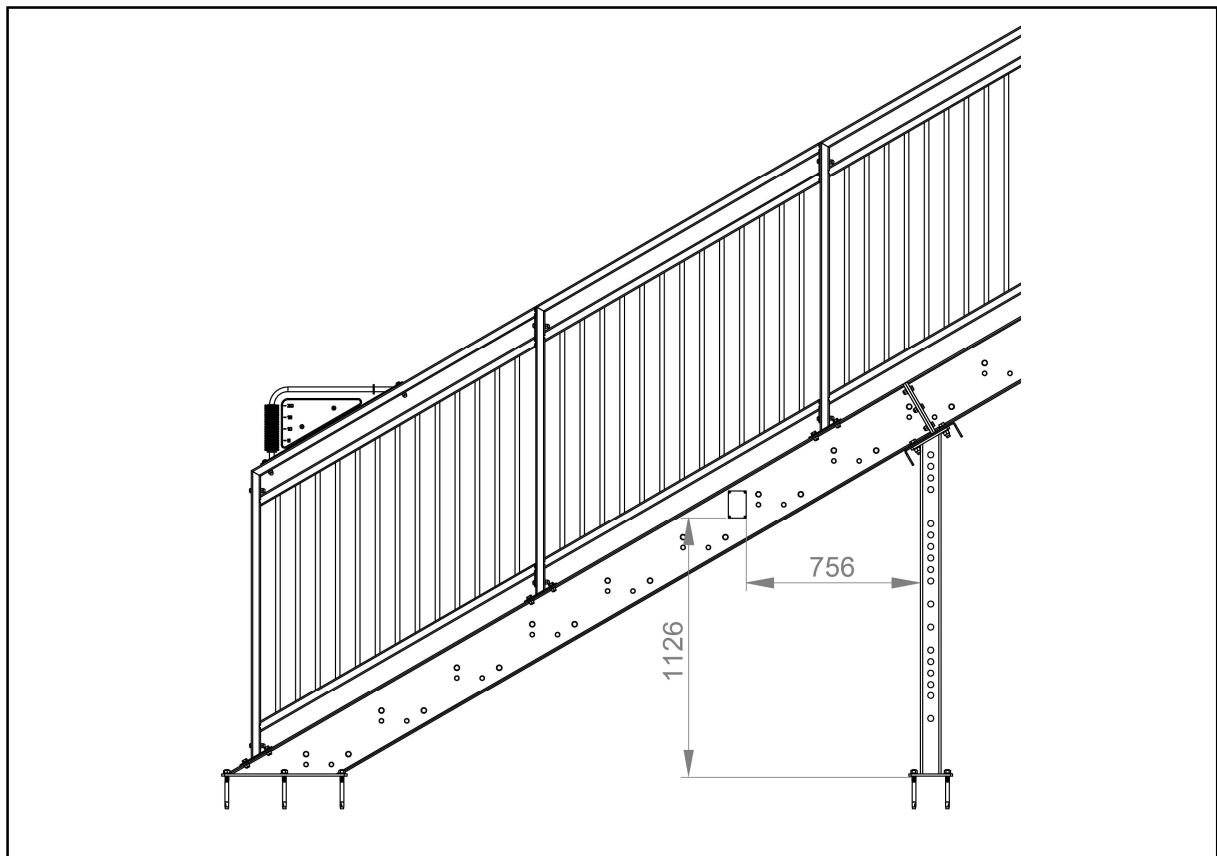
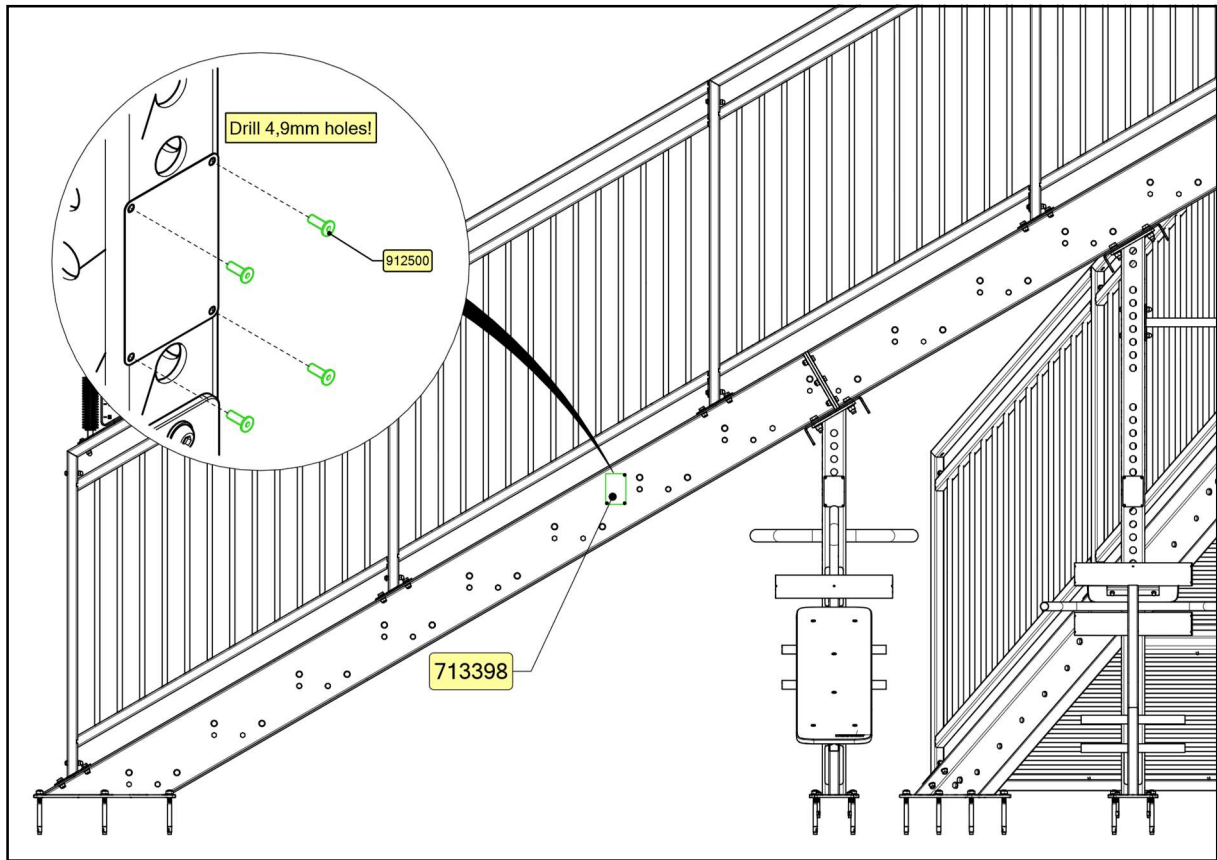

**SISU FITNESS STAIRS**

**SIGN 6**

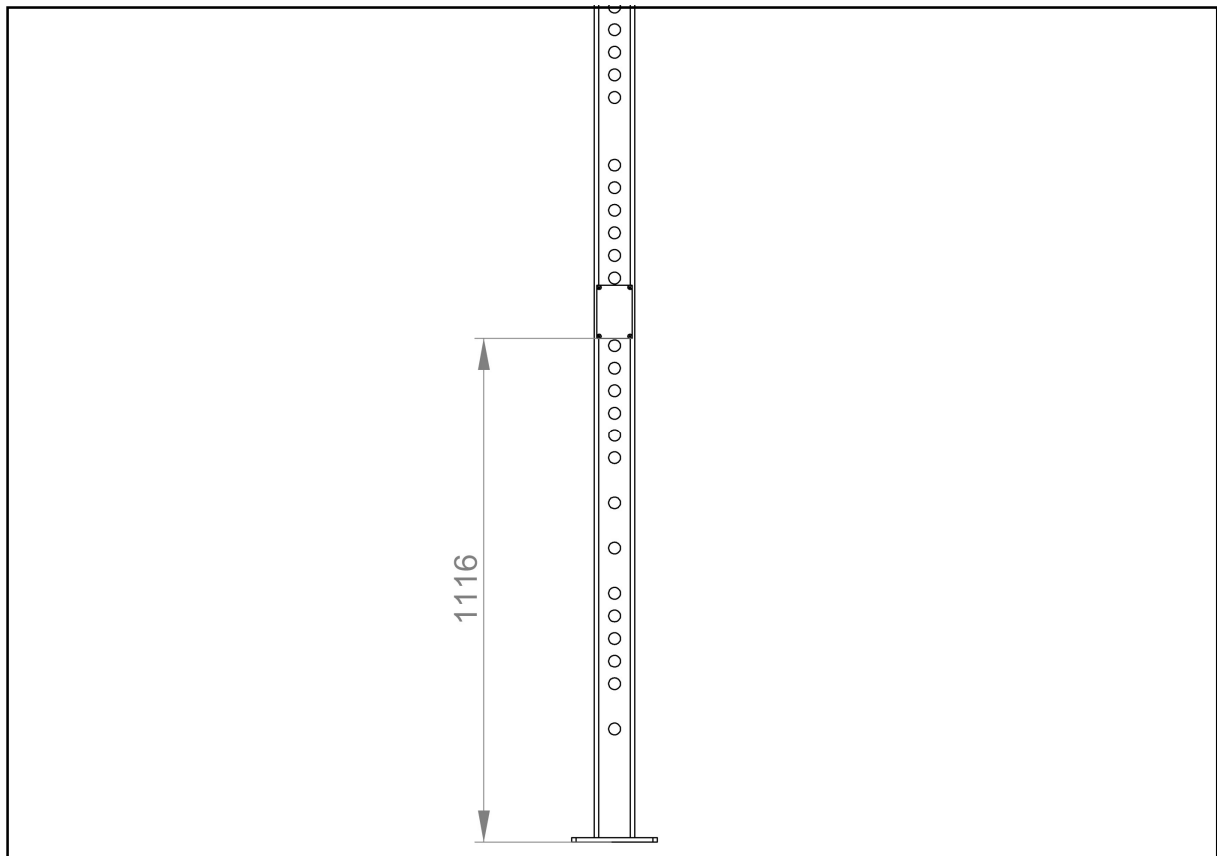
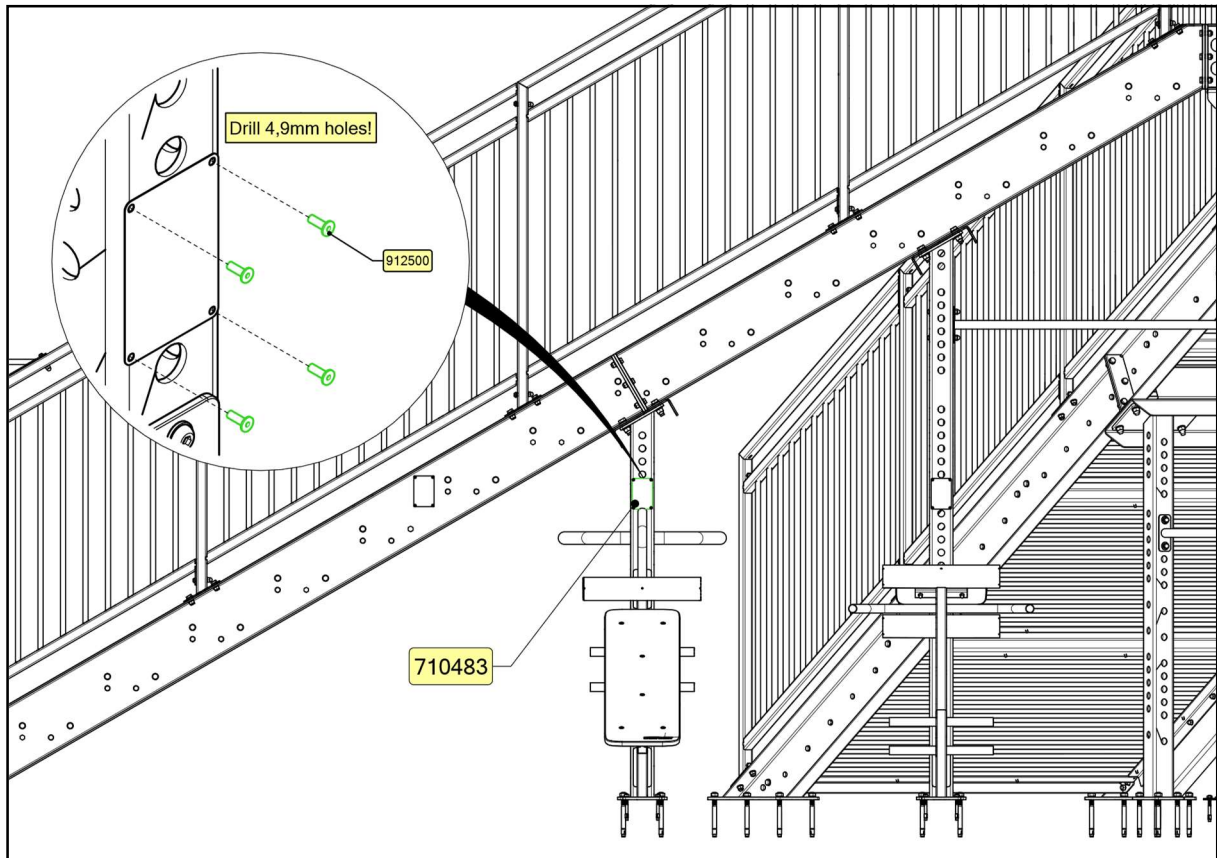

## SISU FITNESS STAIRS

### SIGN 7

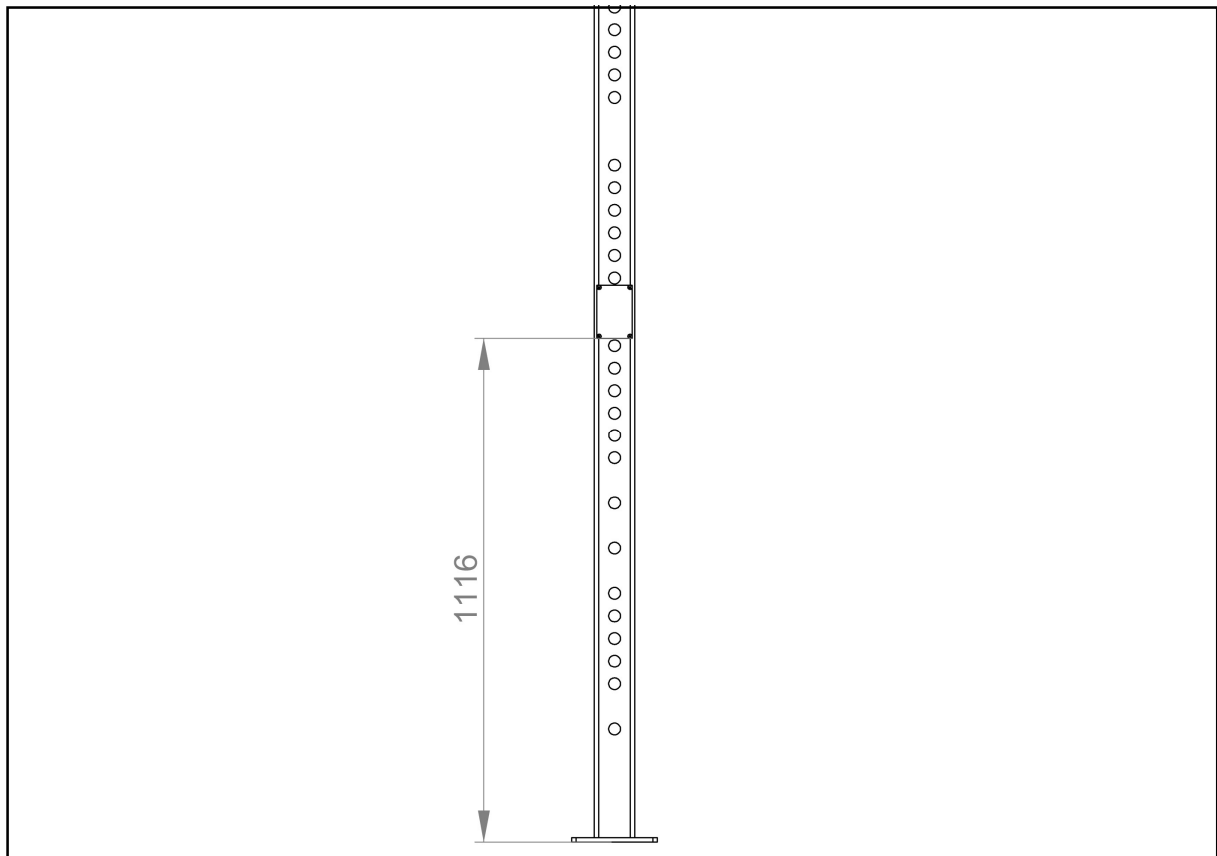
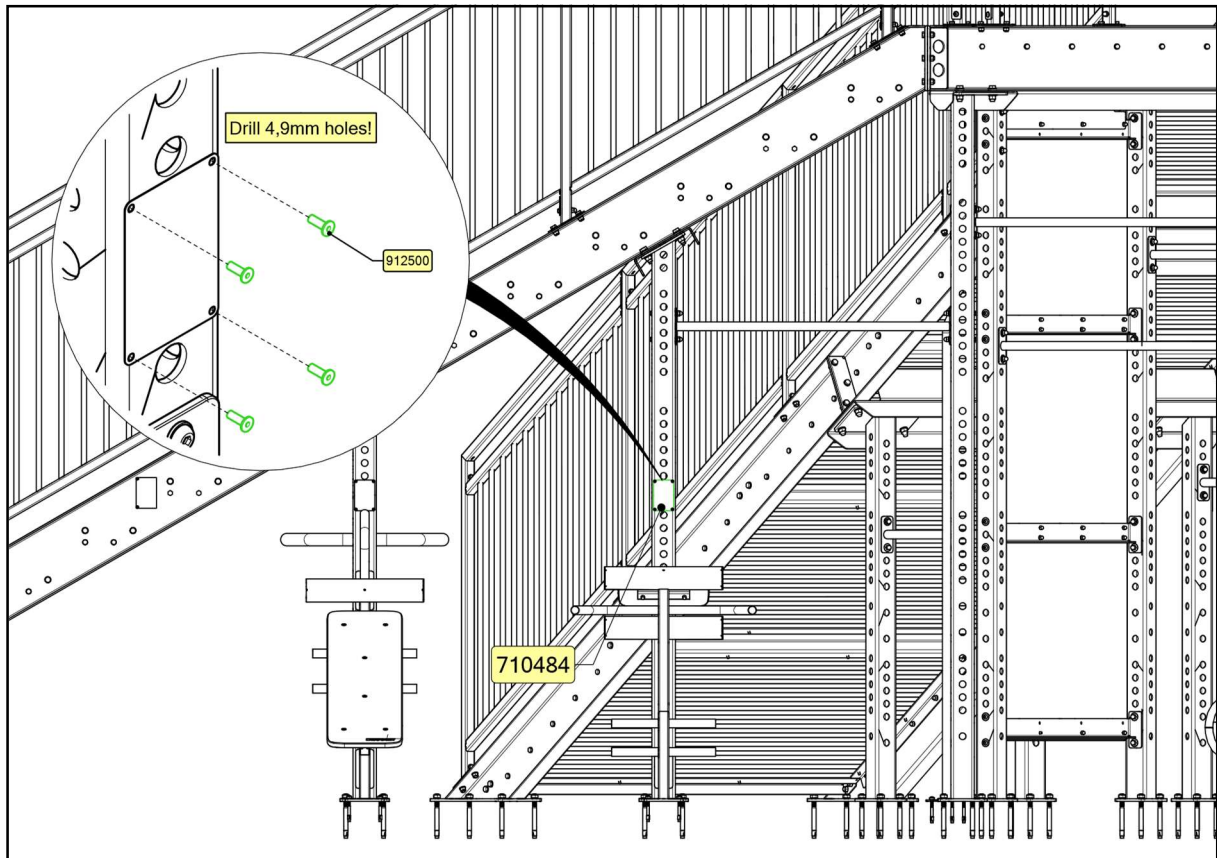

## SISU FITNESS STAIRS

### SIGN 8

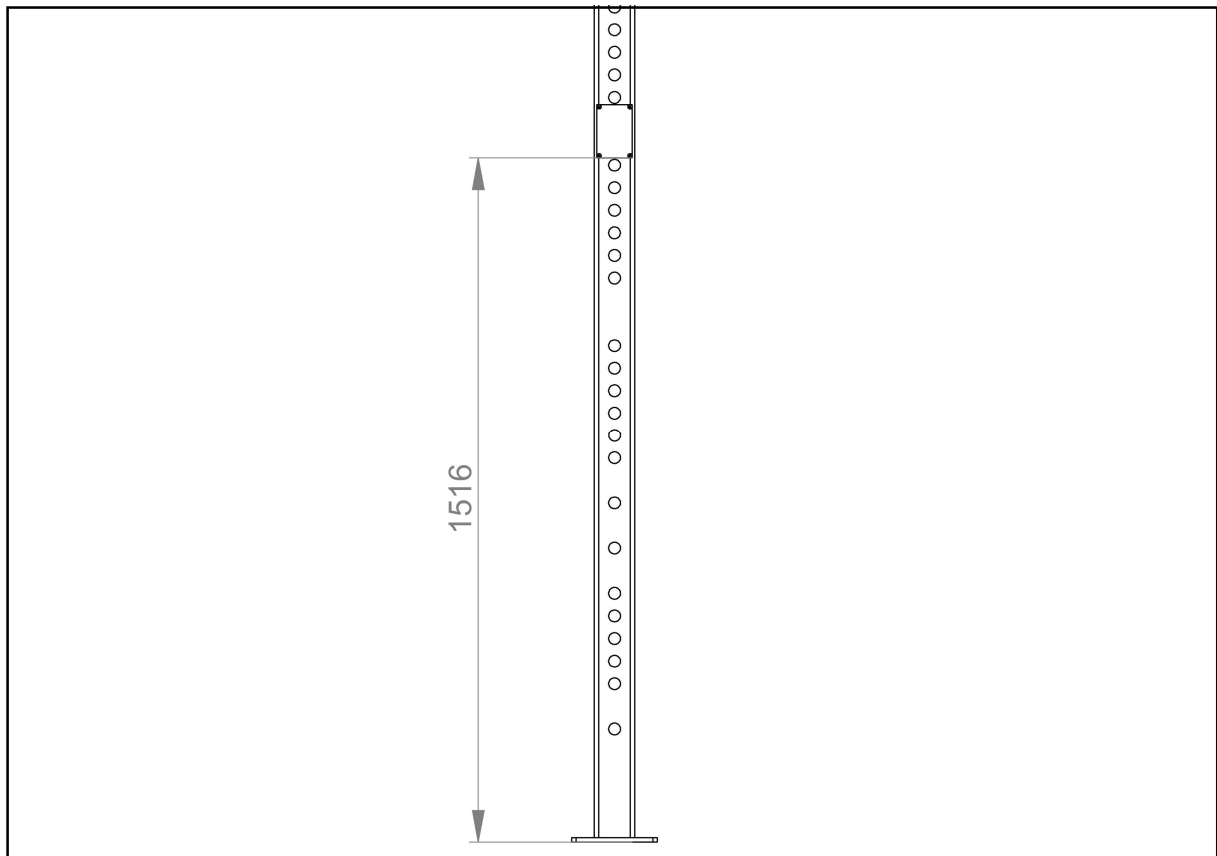
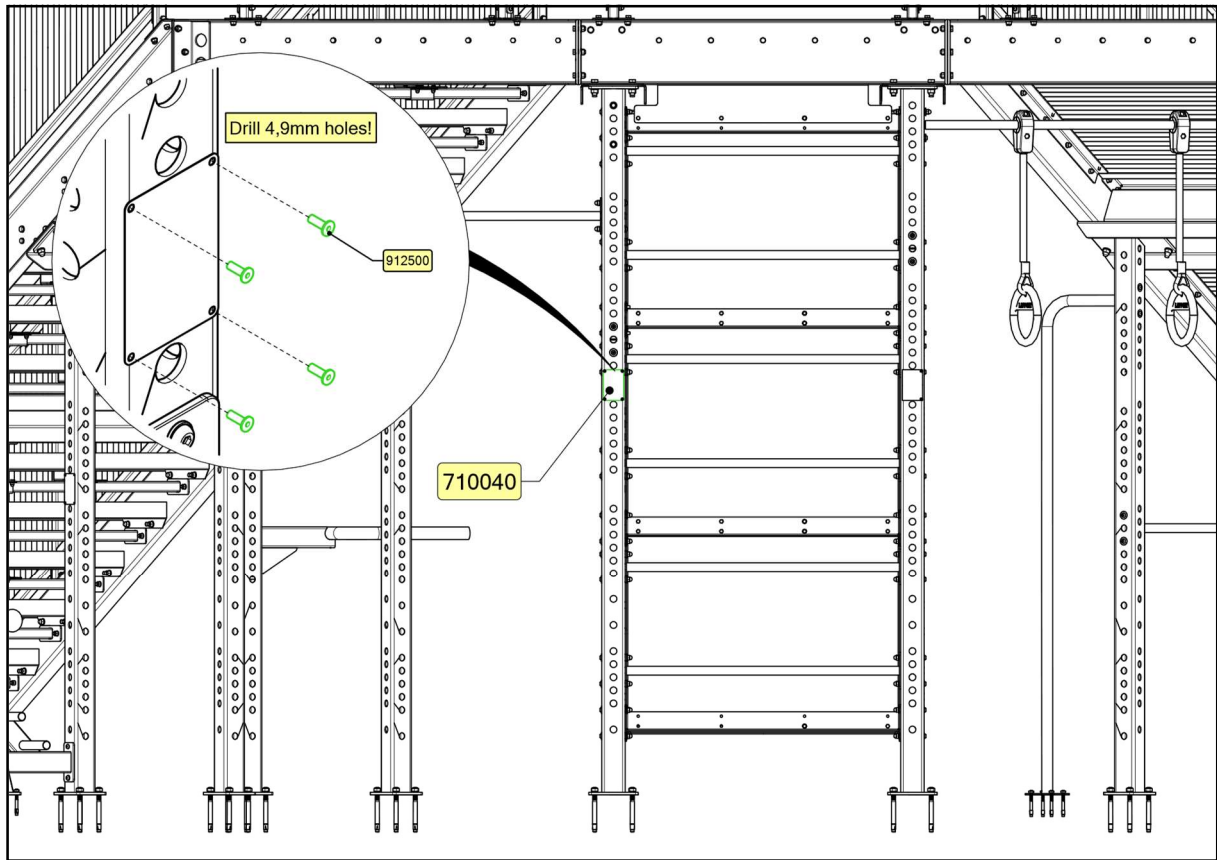

**SISU FITNESS STAIRS**

**SIGN 9**

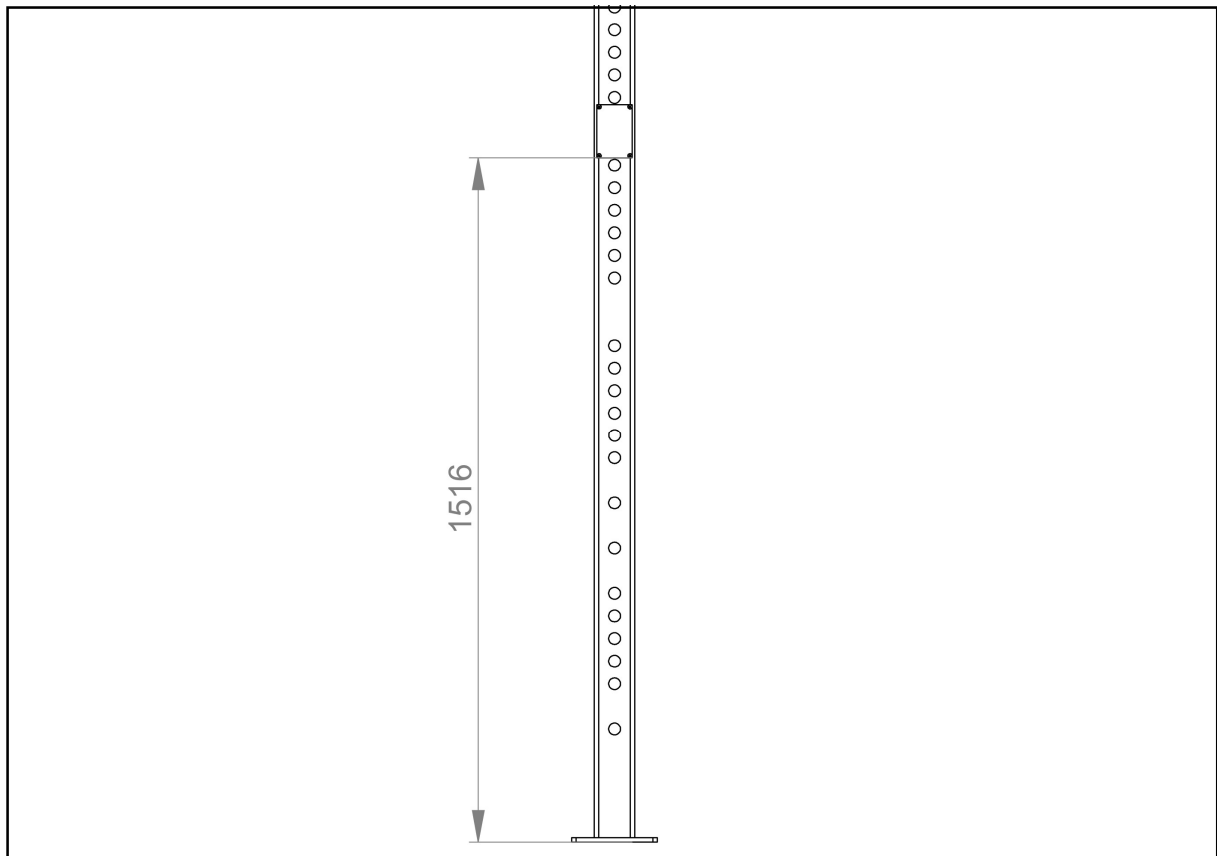
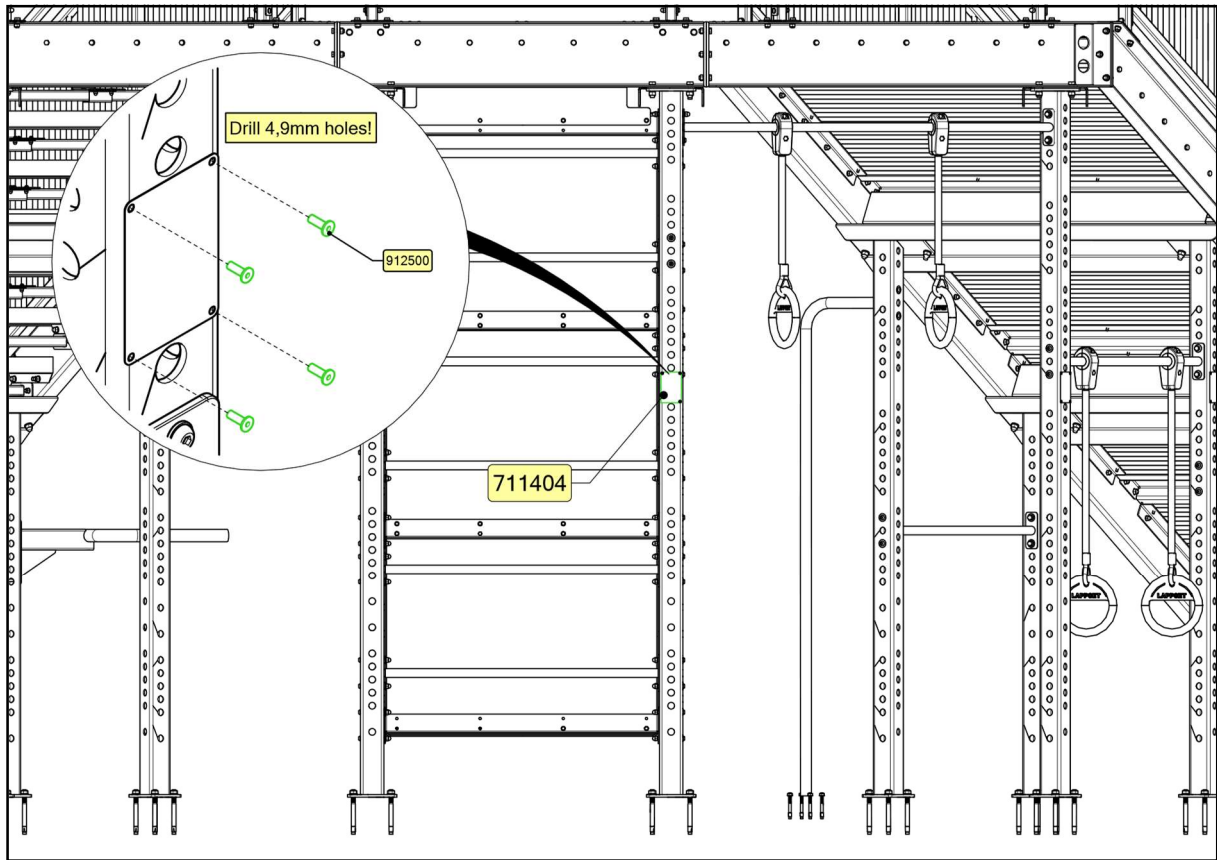

## SISU FITNESS STAIRS

### SIGN 10

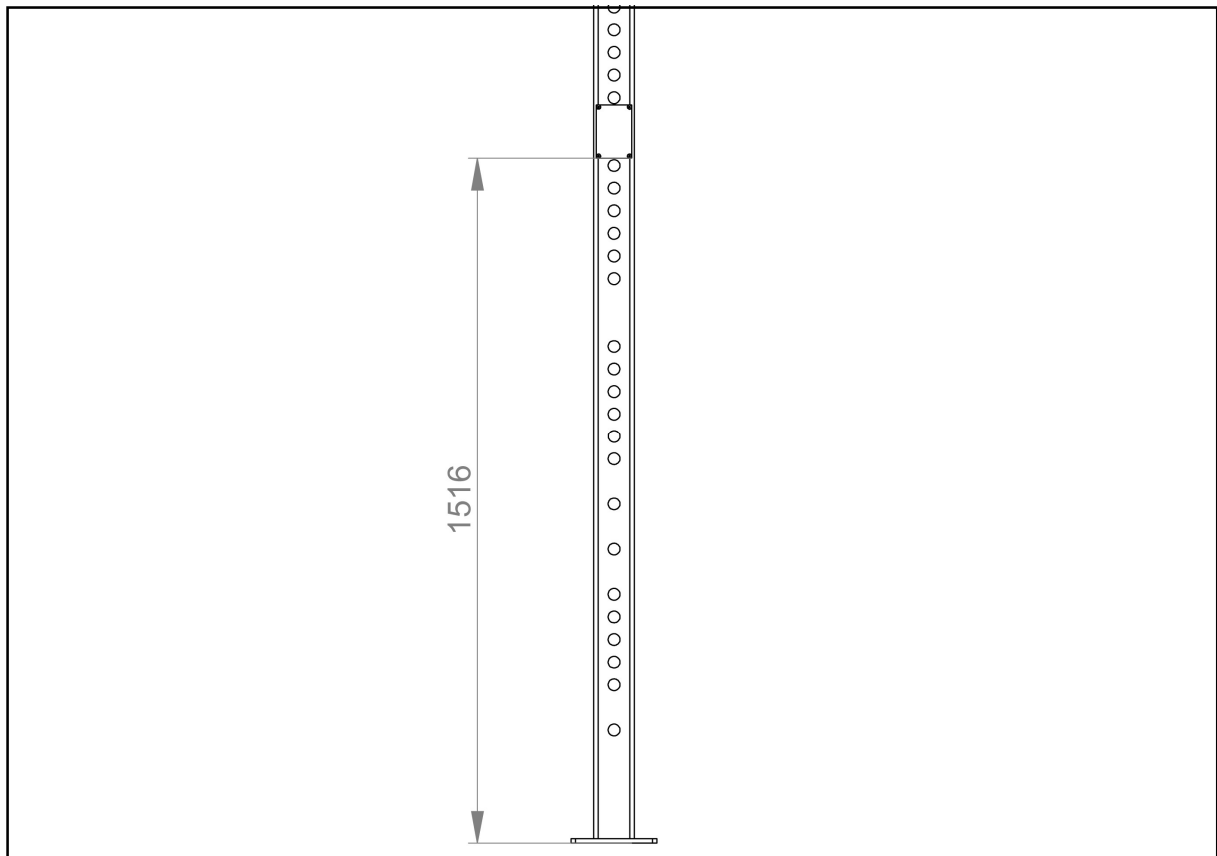
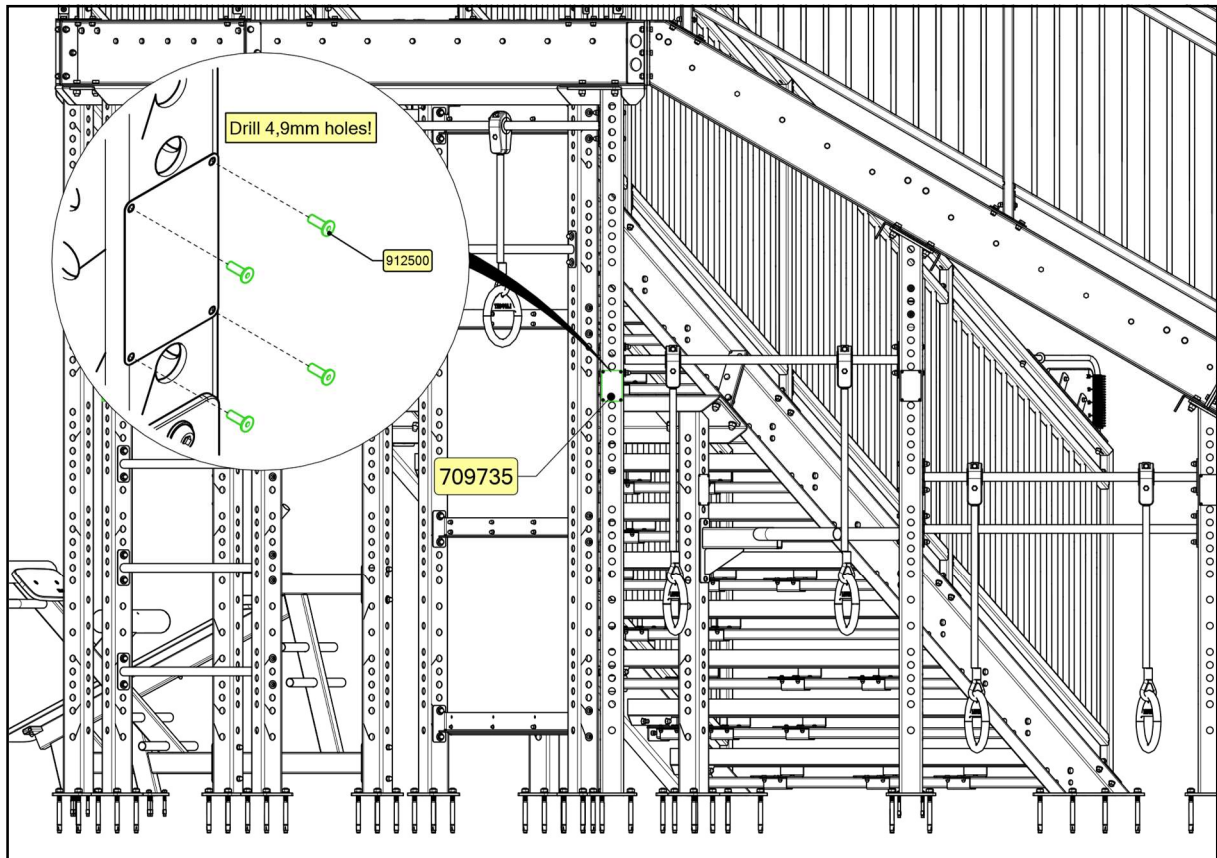

**SISU FITNESS STAIRS**

**SIGN 11**

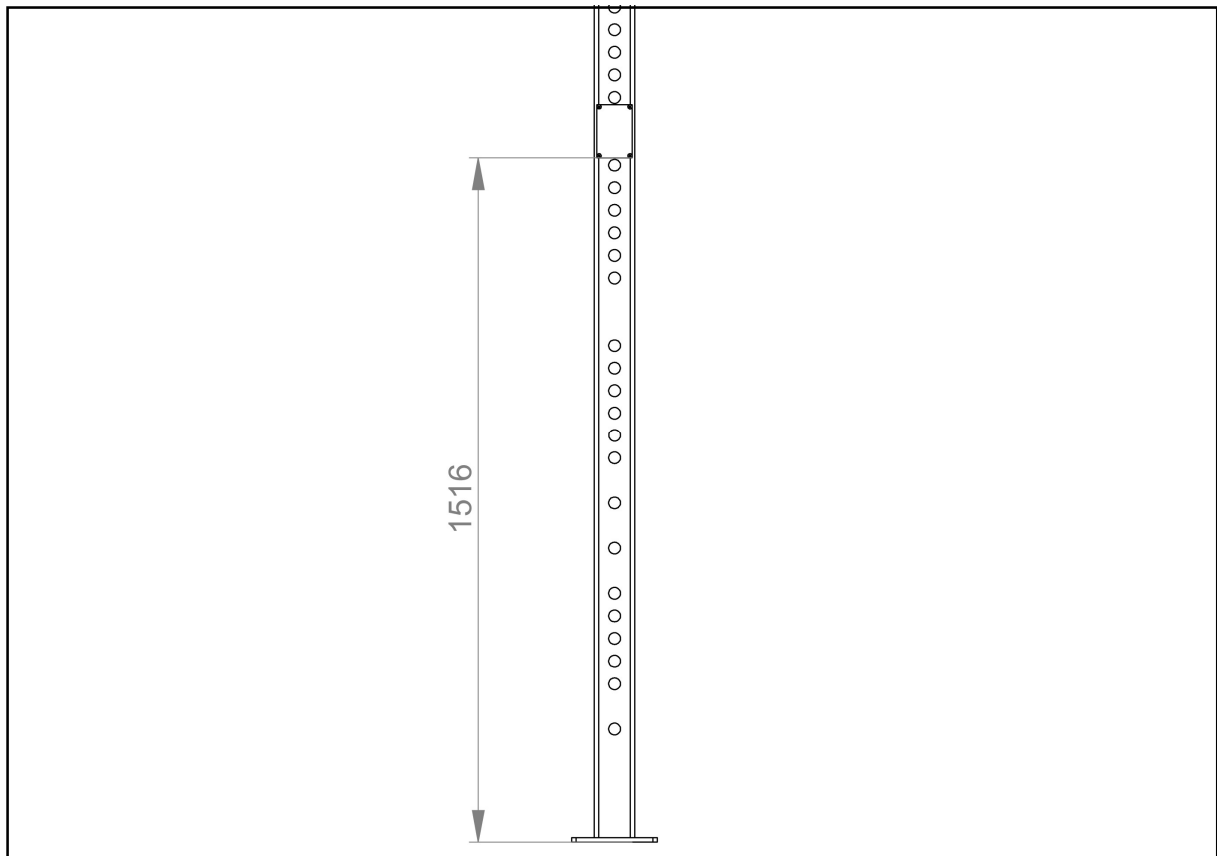
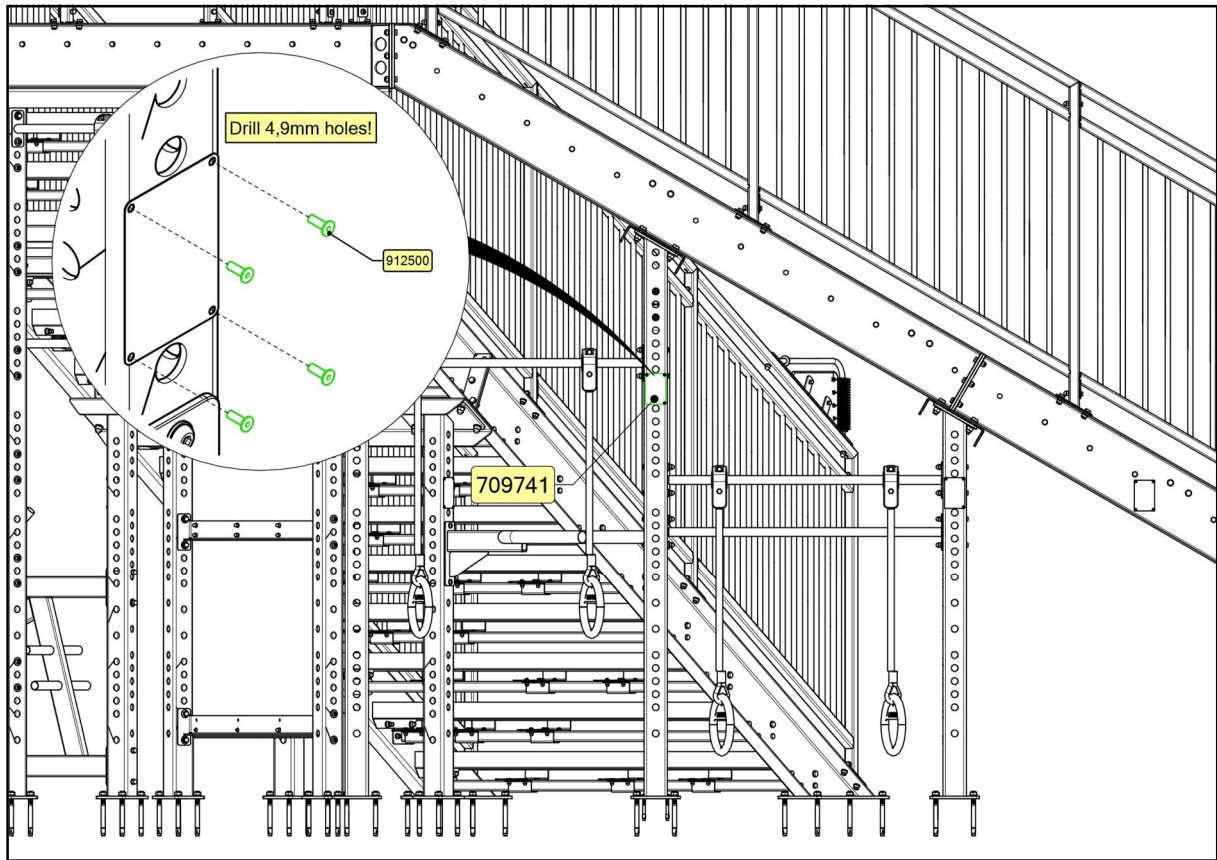

**SISU FITNESS STAIRS**

**SIGN 12**

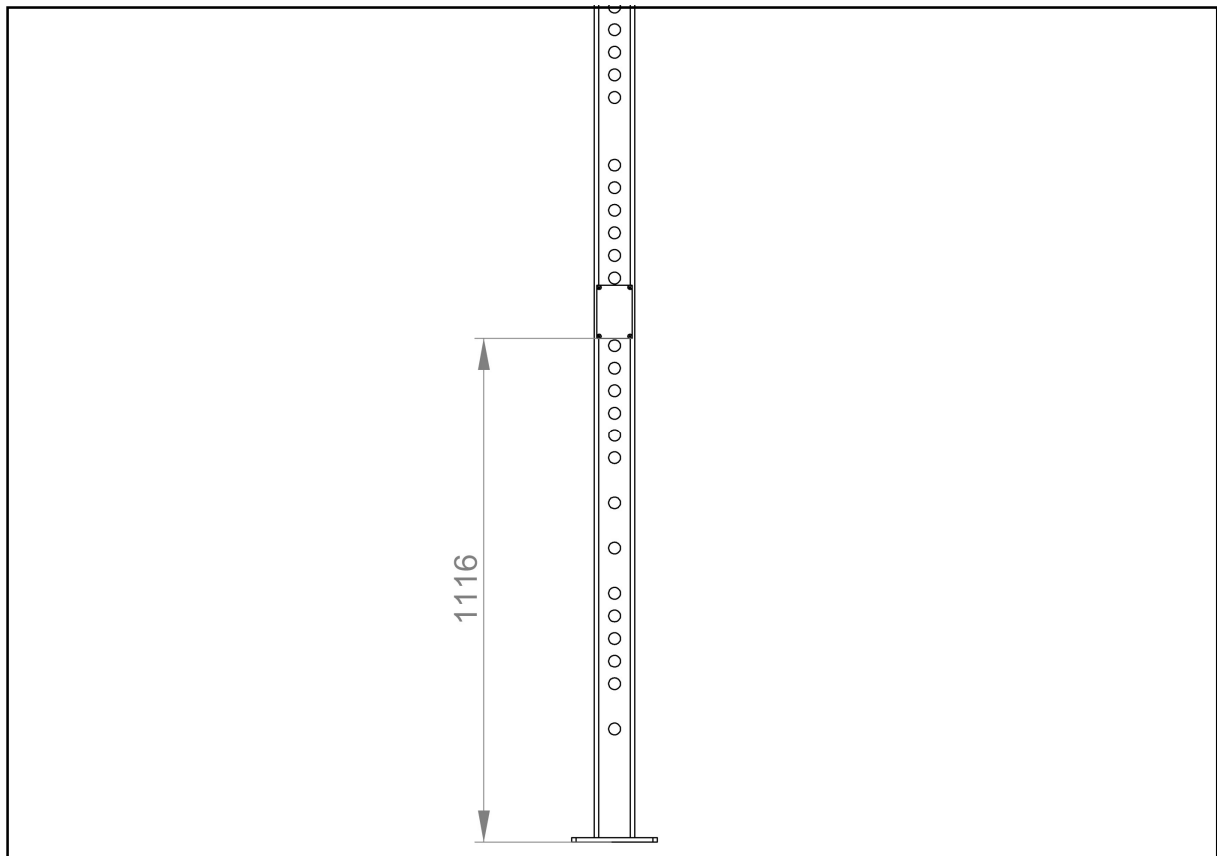
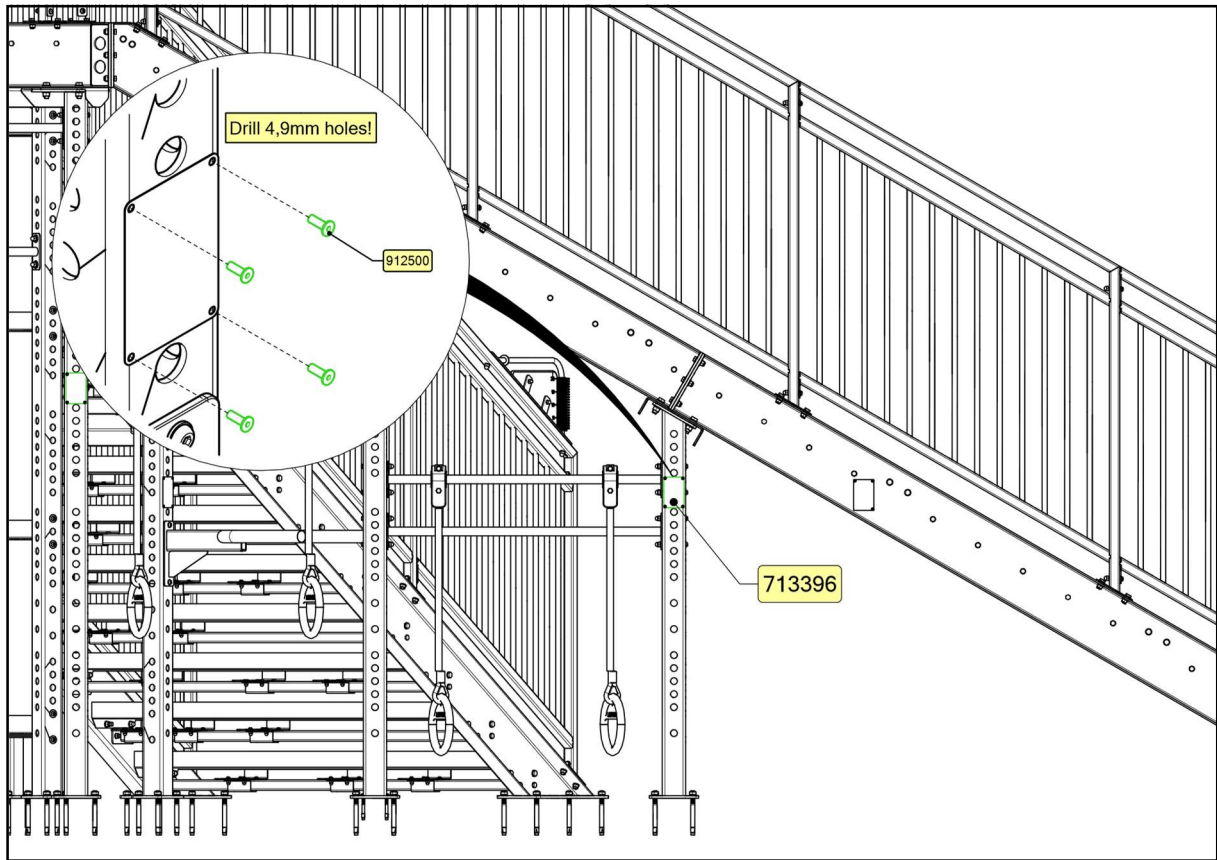

## SISU FITNESS STAIRS

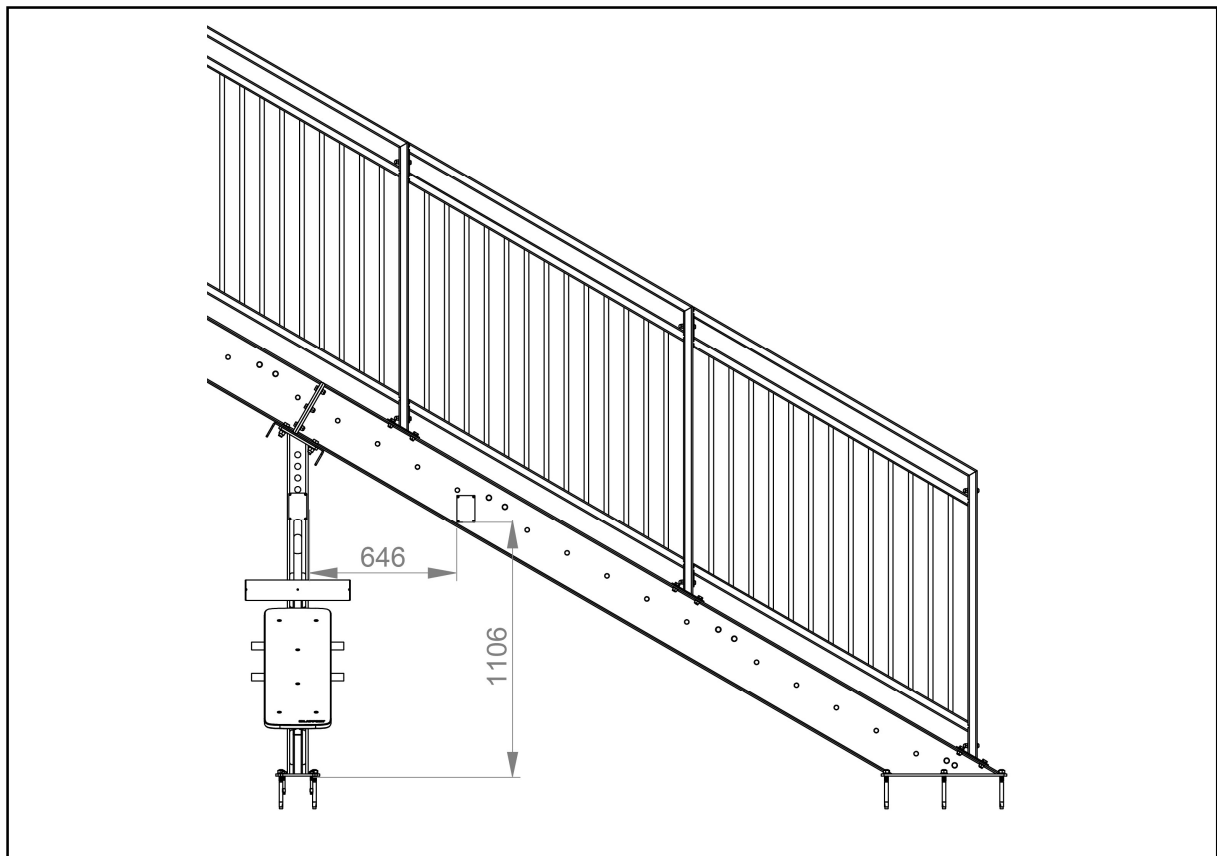
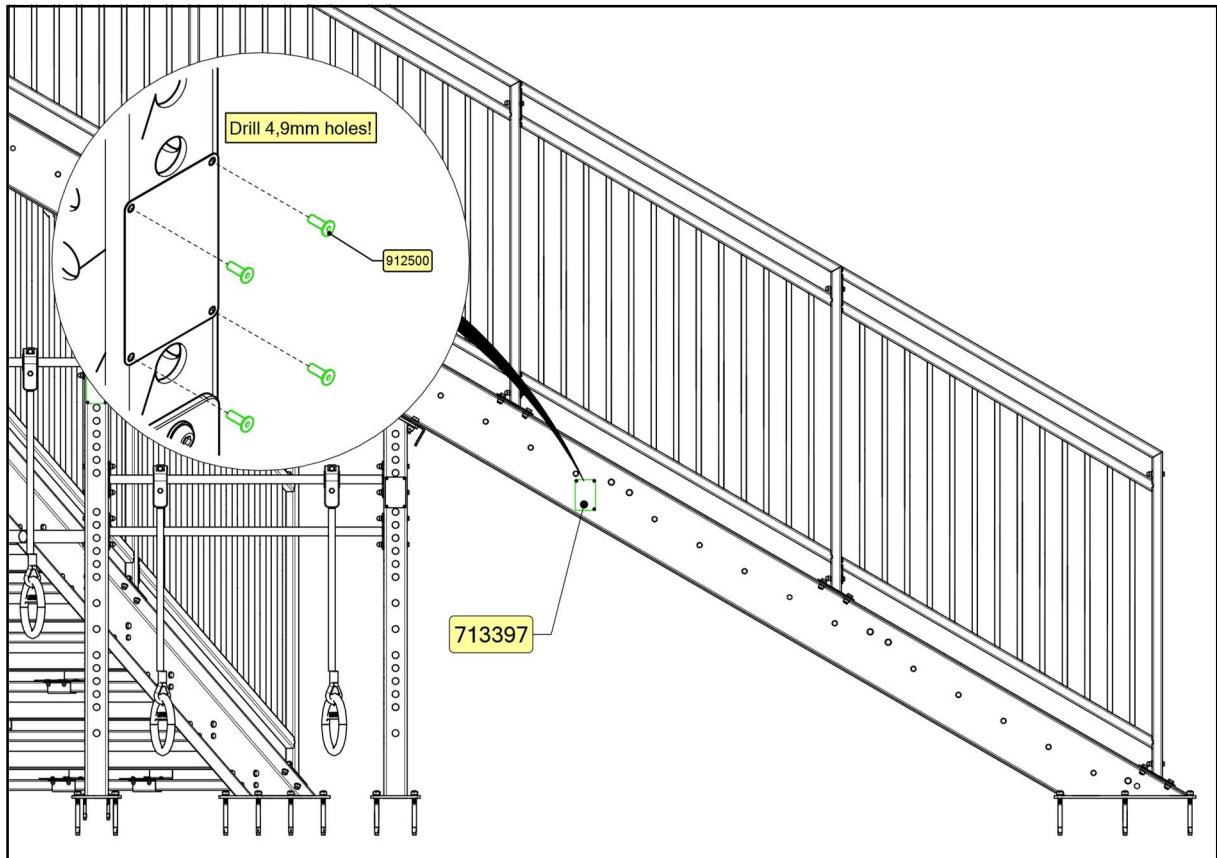

### SIGN 13

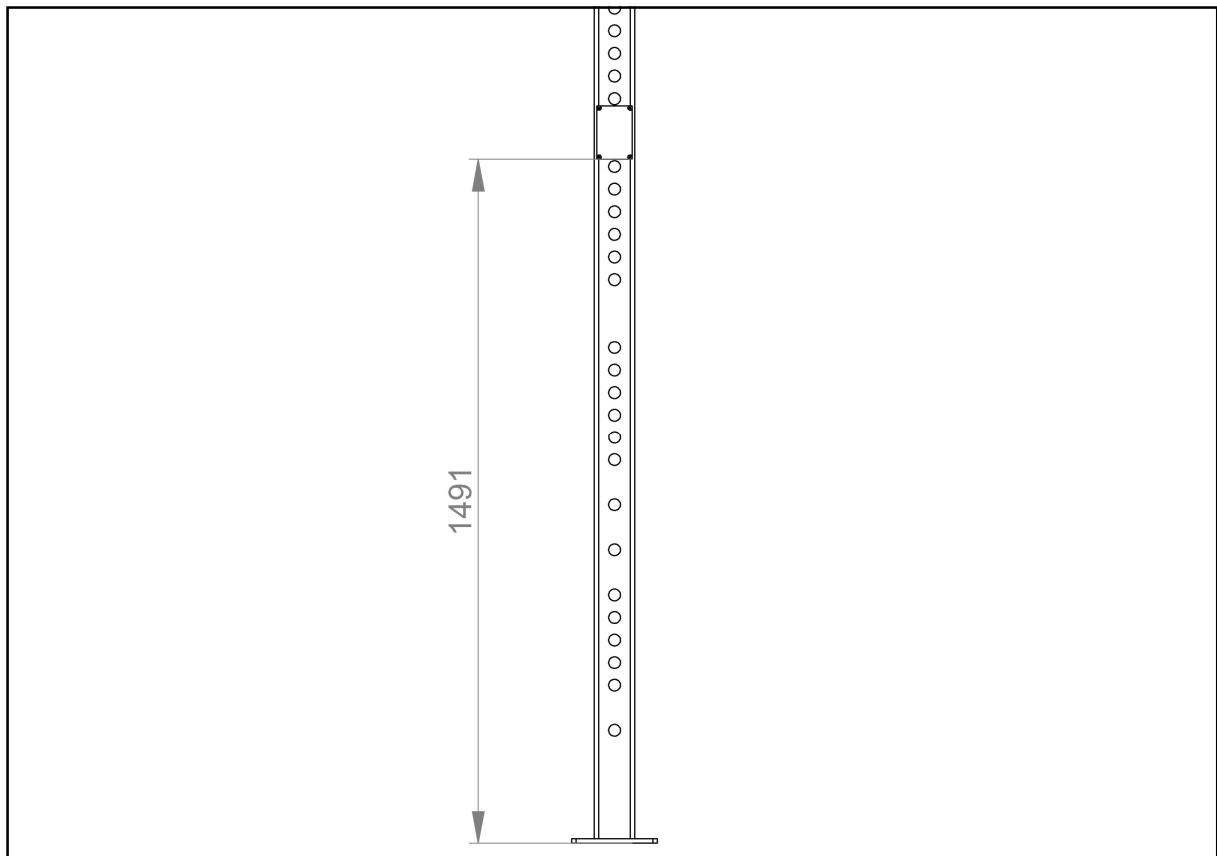
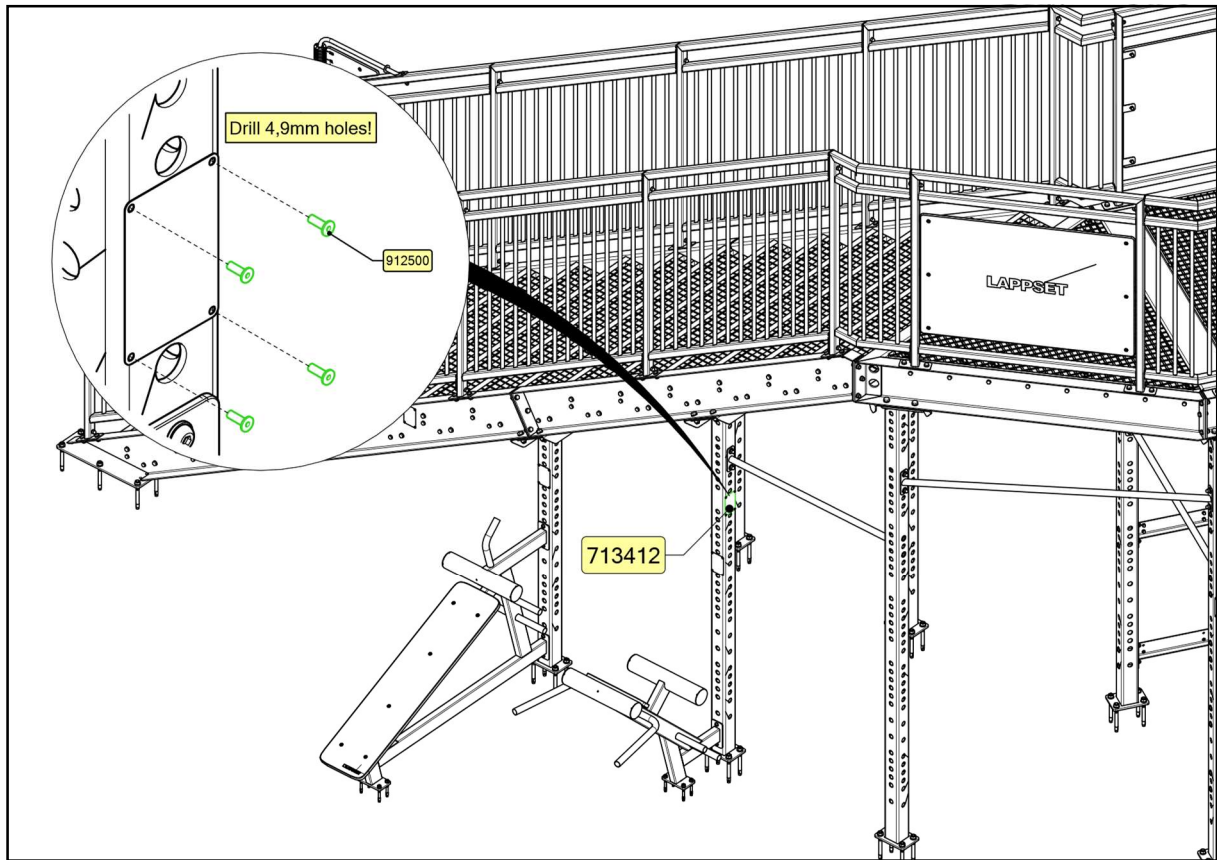

## SISU FITNESS STAIRS

### PRODUCT SIGN

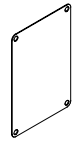

①	SIGN	PCS	②	905390	PCS
 118x78		1	 Ø4,8x28		4

