

# SHOULDER WHEEL

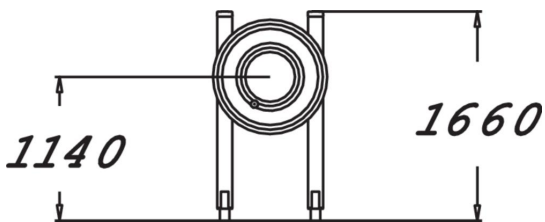

Fitness equipment intended for seniors, consisting of two uprights holding a ring. The ring has two movable balls with different ranges of motion. Rolling the balls on the rings helps to improve shoulder mobility.

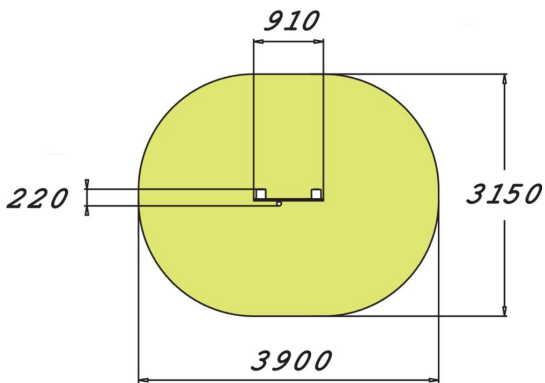

Product length, mm	910
Product width, mm	220
Product height, mm	1655
Safety info	EN 16630, EN 1176-1 TÜV
Installation time (for 1), H	3
Foundation options	Deep mounting Surface mounting