

# **LAPPSET®**

## **DASH PARKOUR**







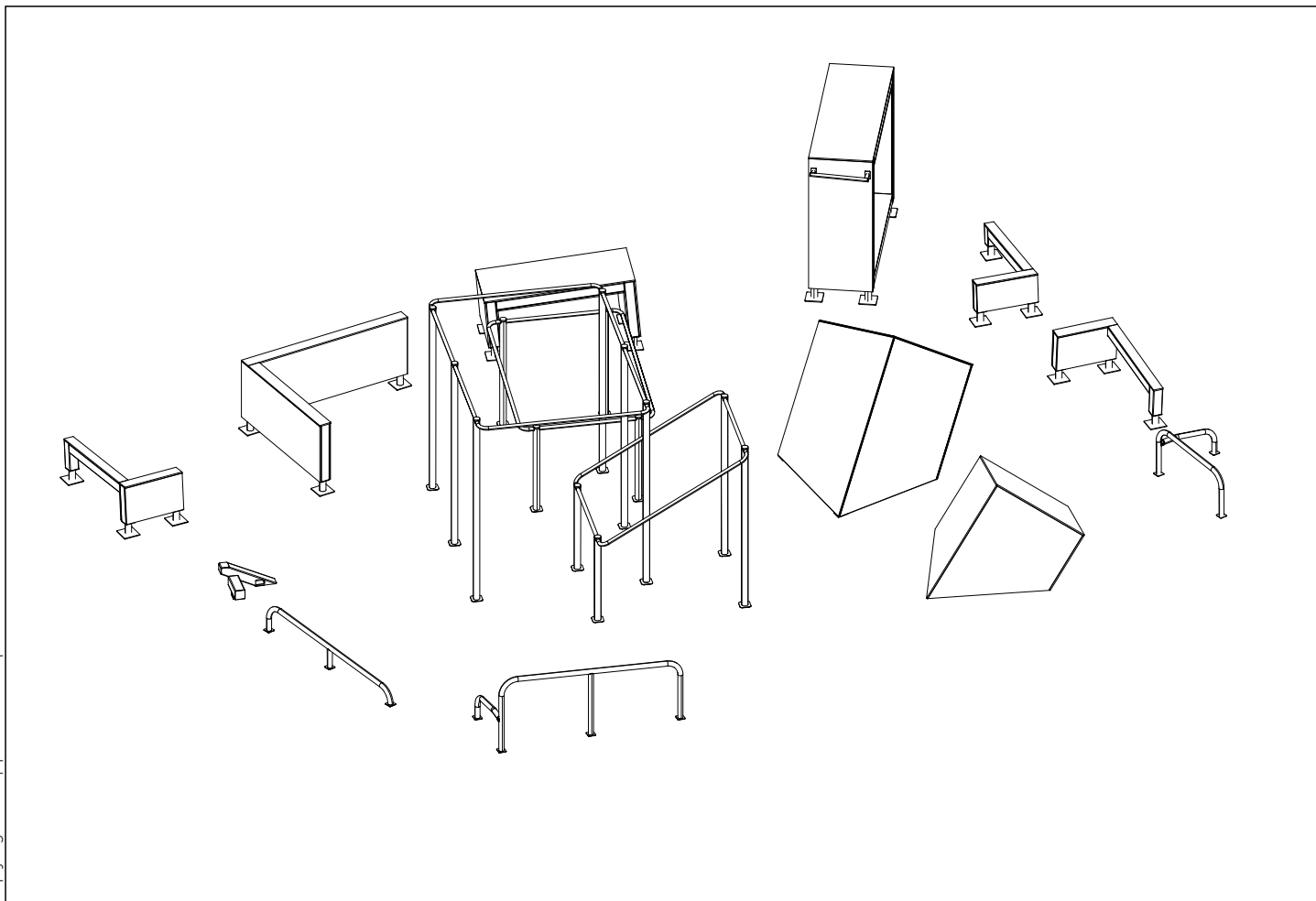



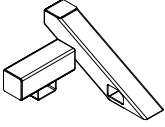
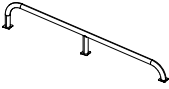
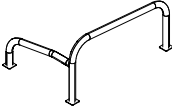
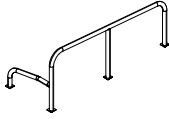
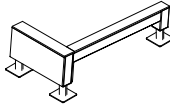
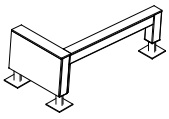

ASENNUSOHJE  
MONTERINGSANSVISNING  
INSTALLATION INSTRUCTION  
AUFBAUANLEITUNG  
NOTICE D'INSTALLATION

DATE: 19.2.2020

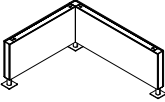
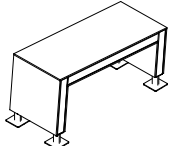
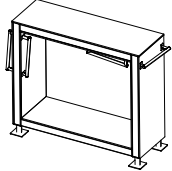
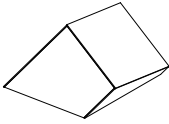
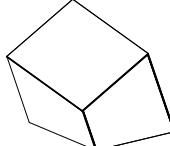
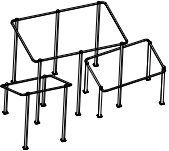
### **081785M**



DATE: 19.2.2020

081701M	PCS 1	081710M	PCS 1	081711M	PCS 1	081712M	PCS 1	081720M	PCS 1	081721M	PCS 2
											
											
081722M	PCS 1	081730M	PCS 1	081733M	PCS 1	081740M	PCS 1	081741M	PCS 1	081751M	PCS 1
											
											
	PCS		PCS		PCS		PCS		PCS		PCS
	PCS		PCS		PCS		PCS		PCS		PCS
	PCS		PCS		PCS		PCS		PCS		PCS
	PCS		PCS		PCS		PCS		PCS		PCS

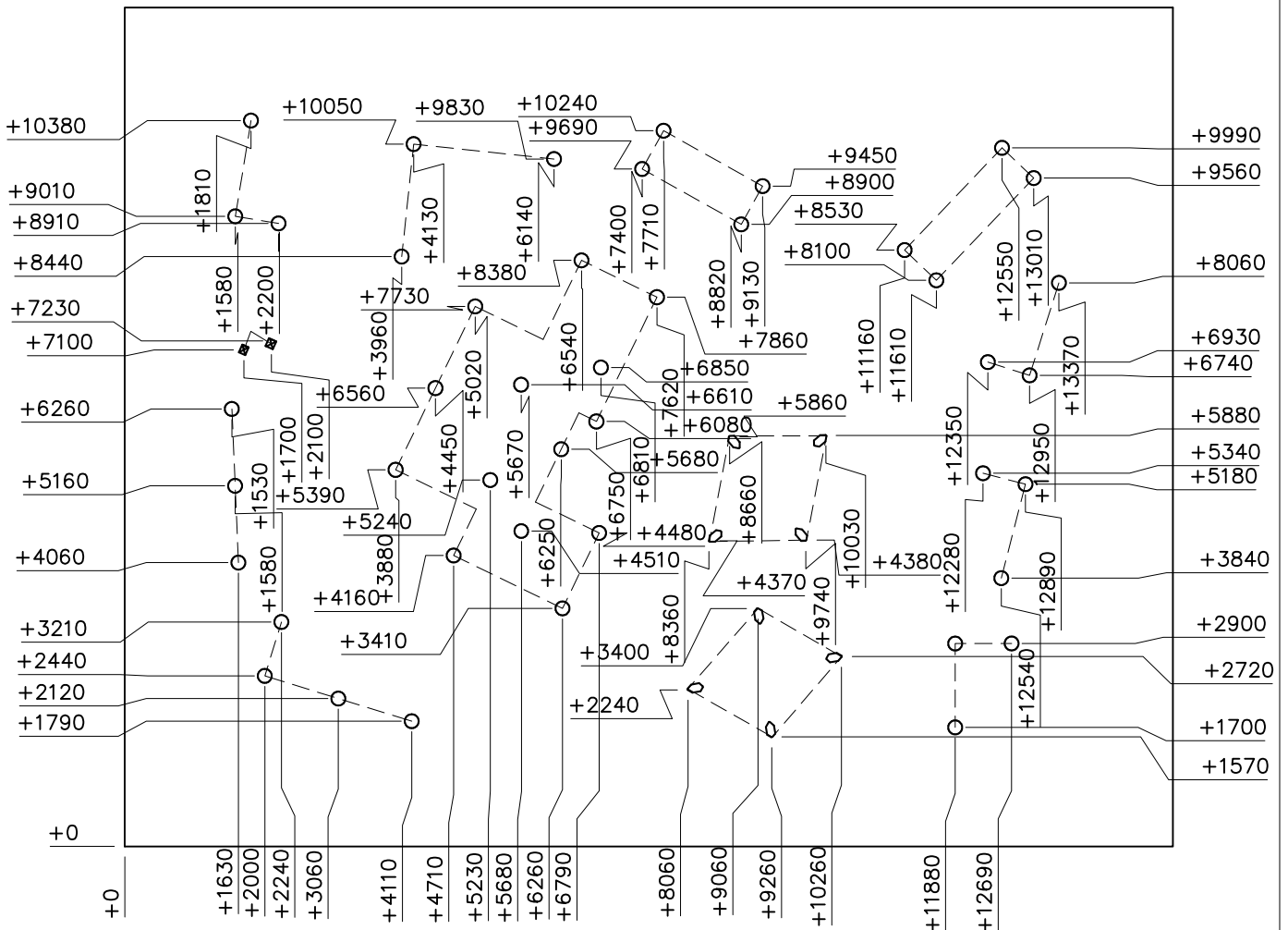
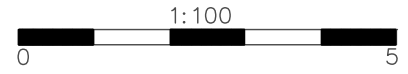

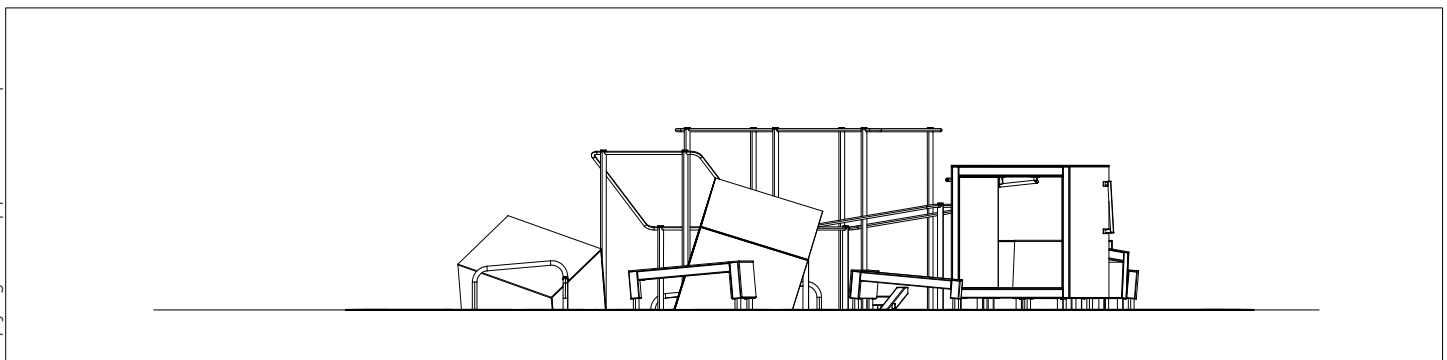
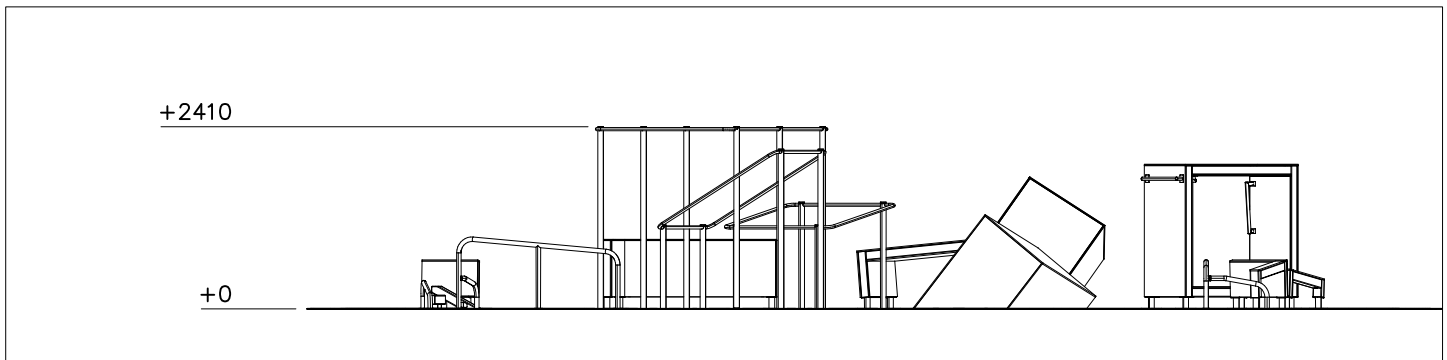
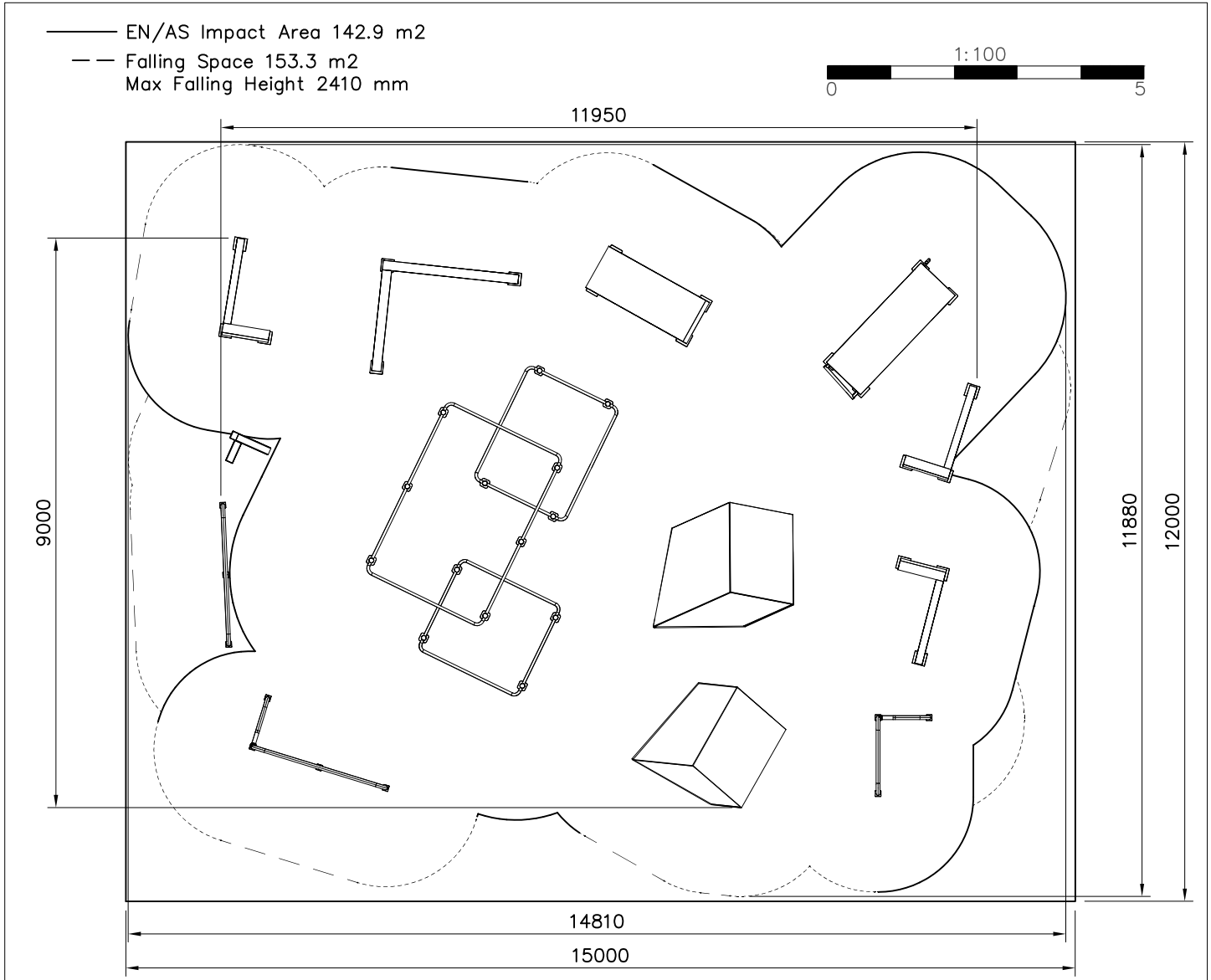

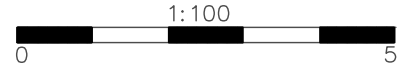

# Groundmarks

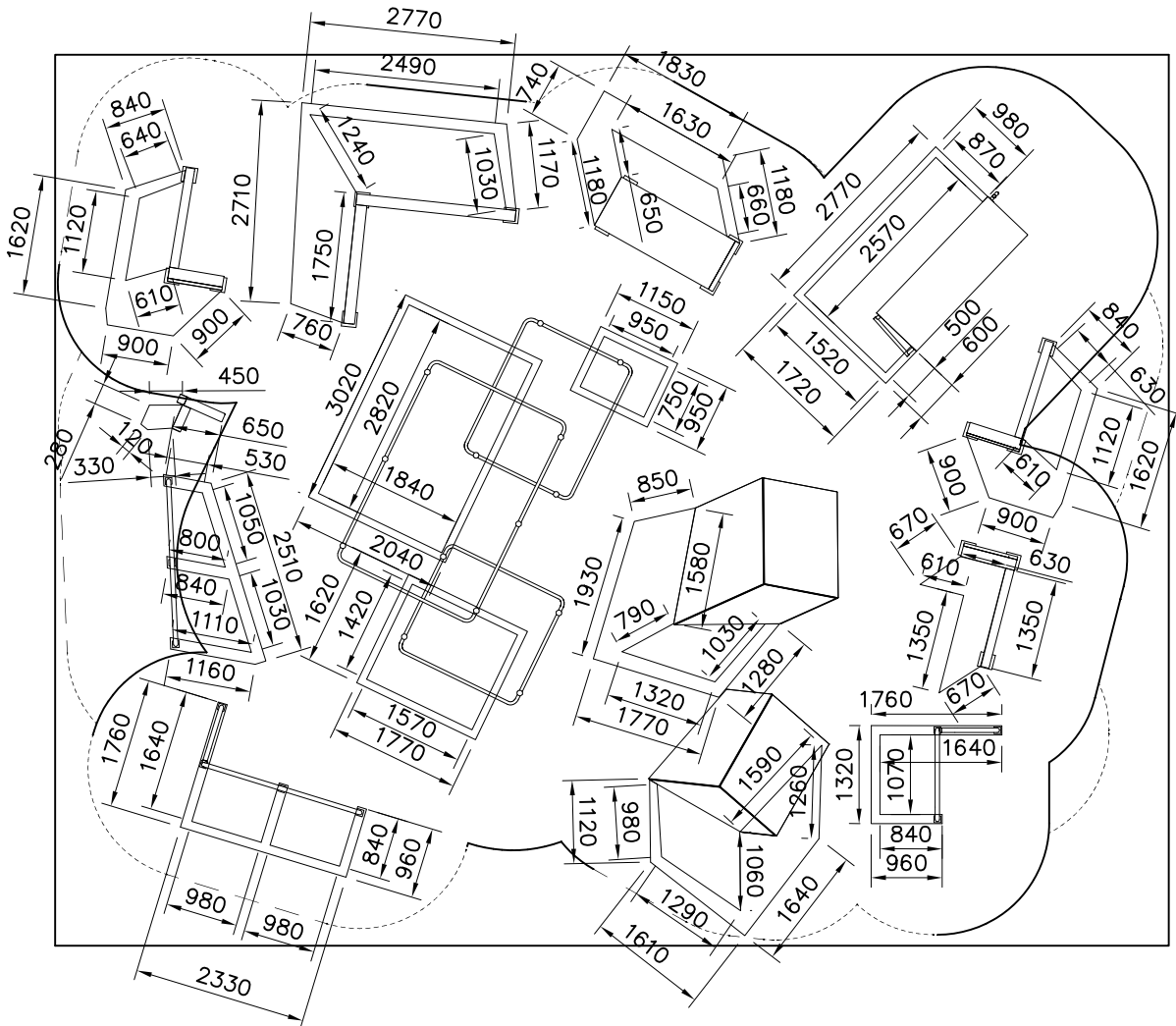

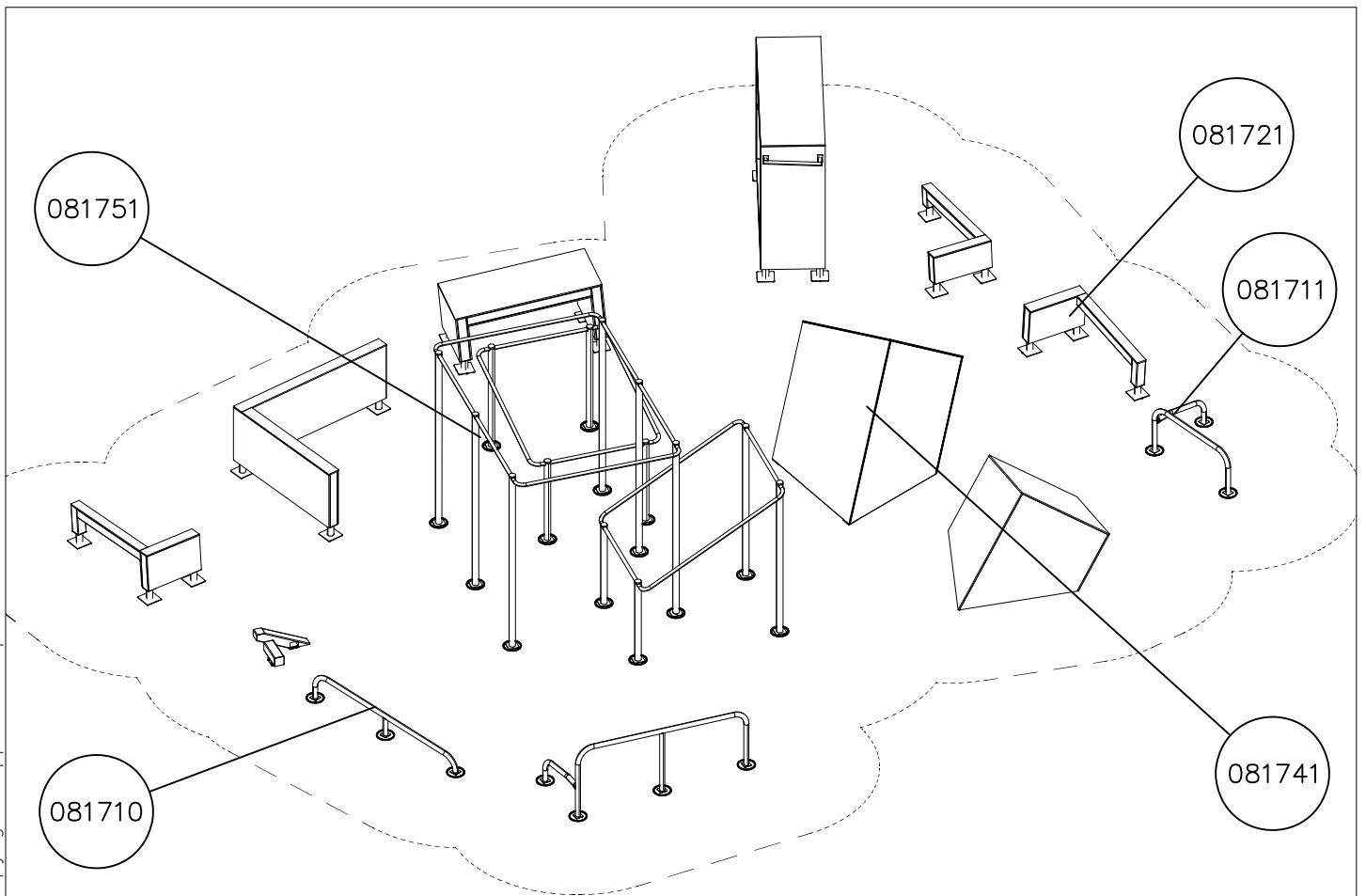
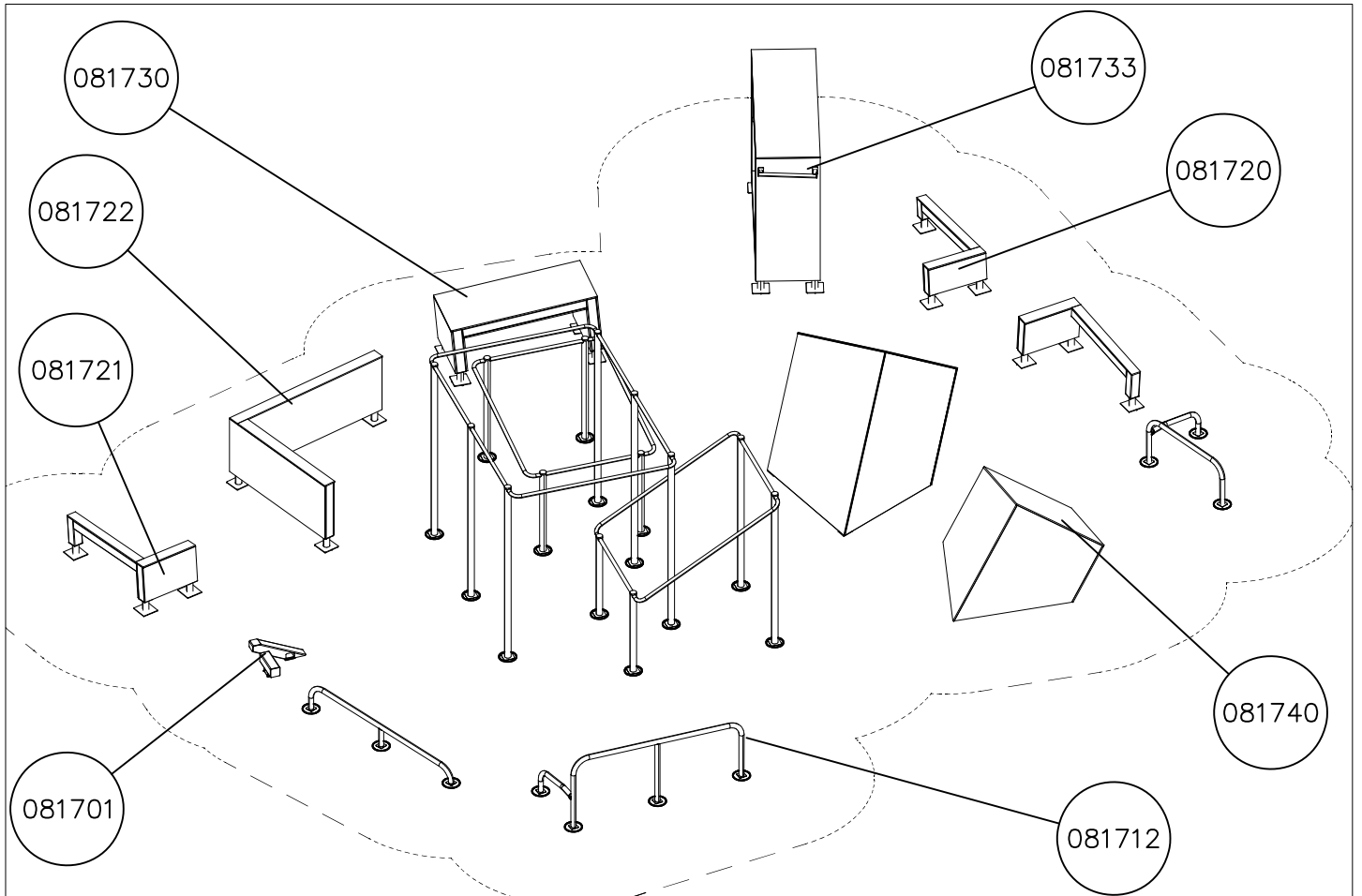

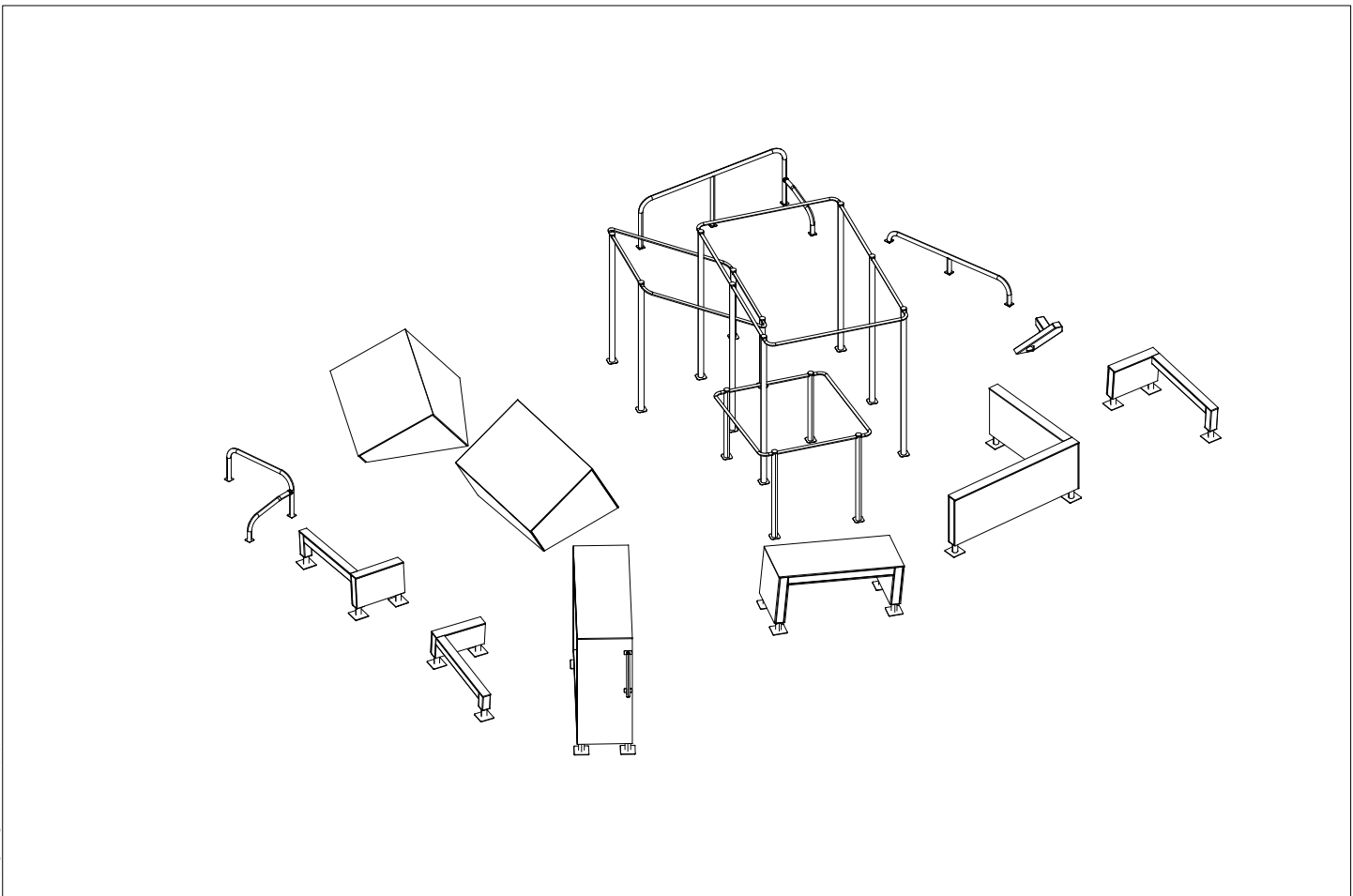
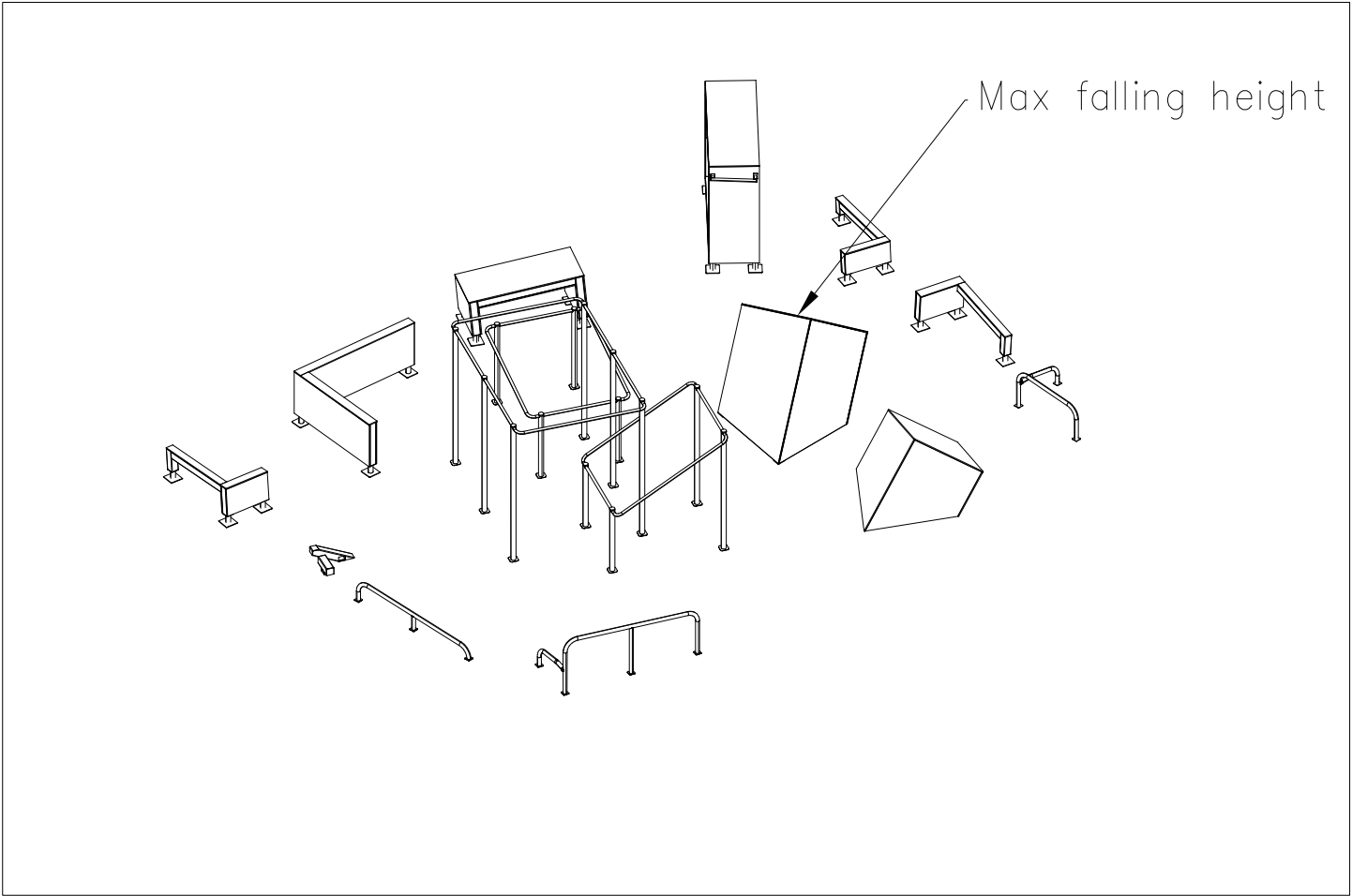

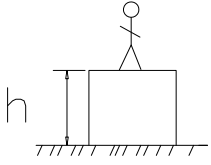

$h < 1600$

Totally hard surfaces or materials with very limited impact attenuating properties.

Case by case risk assessment is needed including e.g. evaluation whether there is forced movement, what is the intended exercise and where will the product be installed.

Materials with significant impact attenuating properties.

Totally hard surfaces.  
E.g. concrete or asphalt



Materials with very limited impact attenuating properties.  
E.g. wood



fine gravel 0–8 mm

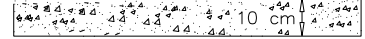

Unsorted sand/ topsoil

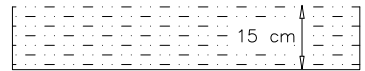

Lawn

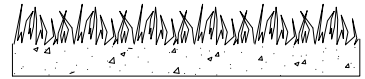

$h = 1600-$

$h < 3000$

Loose fill material

E.g.  
sand/gravel 0,25...8 mm  $D_{60}/D_{10} < 3,0$   
Woodchips 5...30 mm  
bark 20...80 mm

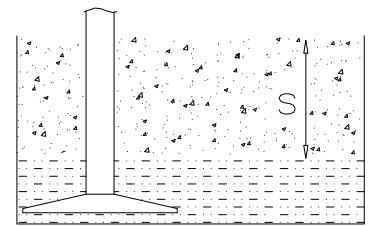

$\underline{S}$   
30 cm       $\underline{h}$   
                 < 3,0 m

Synthetic granulates

$\underline{S}$	$\underline{h}$
40 mm	~> 1,6...~< 1,8 m
50 mm	~> 1,8...~< 2,25 m
55 mm	~> 2,25...~< 2,4 m
60 mm	~> 2,4...~< 2,55 m
70 mm	~> 2,55...~< 3,0 m

Note. For accurate values, see manufacturer's instructions.

