

Ann Balancing Step

Prime , F24809M

Ann Balancing Step brings movement, balance and challenge to ground-level play. Children aged 3 or more can step, hop, or crawl along the fun path. Building coordination, motor skills, and confidence with every move. The low profile and fall height make it especially suitable for early learners exploring movement at their own pace. Balancing steps fits well in outdoor places like schoolyards, parks, and early childhood centres, especially when combined together with other low level balancing solutions.

Basic information

User Age	3+
Number of Users	1
Safety Standard	EN 1176-1:2017

Technical information

Amount of Concrete, m ³	0.03	Height, mm	250
Largest Part, mm	800	Max Free Fall Height, PLAY, mm	250
Netto Weight, Total Shipping Weight, kg	5.035	Minimum Space/Height, mm	2050
Heaviest part, kg	3.4	Width, mm	250
Falling Space, Length, mm	3250	Falling Space, Width, mm	3250
Falling Space, m ²	8	Length, mm	250

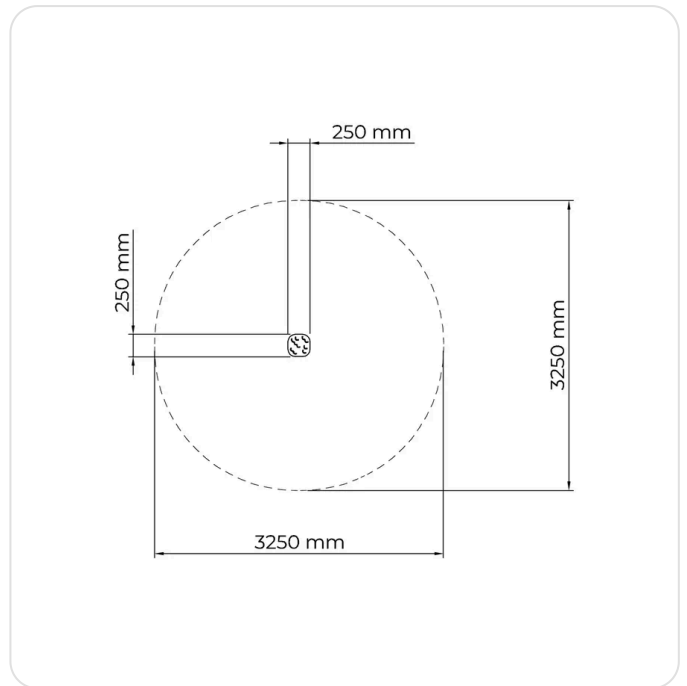
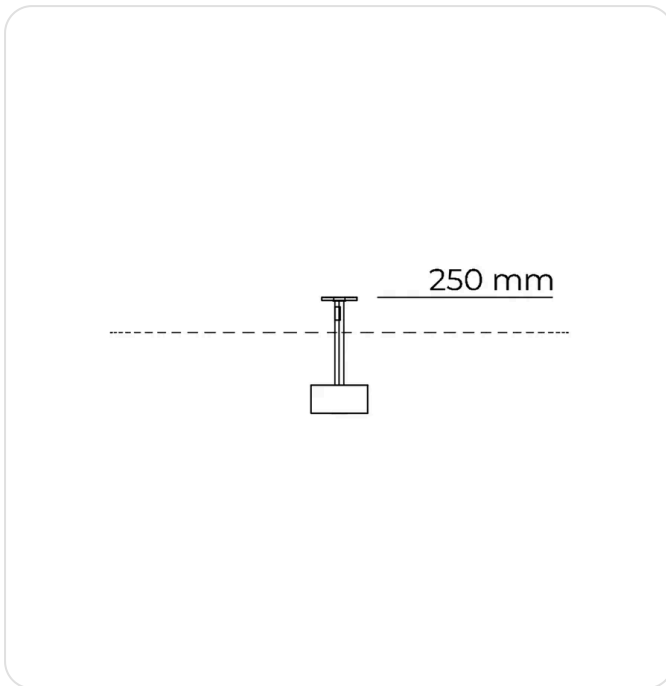

① Installation instructions: <https://lap-integrations-prod.azurewebsites.net/api/pim/installation-instructions?productN...>

① Read more about installation: <https://www.lappset.com/en-GB/playground-installation>

General warranty information

- **20 years:** Steel components and high-pressure laminate (HPL)
- **15 years:** Wooden posts
- **10 years:** Surface finish of steel and aluminum, and hot-dip galvanized surface treatment
- **10 years:** Guaranteed availability of spare parts
- The general warranty terms do not apply to third-party products.
- This overview covers the main warranty periods for Lappset's key materials.

For full details and specific terms or limitations, please see the complete warranty conditions [here](#).

① Read more about warranty: <https://www.lappset.com/en-GB/warranty>

Metal parts

- Platinum grey NCS
S4005-Y50R

Walls/HPL parts

- Bubblegum pink
- Lemonade yellow RAL
1018
- Terracotta red RAL 8004
- Lake blue RAL 5009
- Platinum grey NCS
S4005-Y50R