



1132EPON



Description

1 tower with gable roof, 1 deep slide, 1 safety HDPE boards with decorative cuts, 1 spiral ladder, 1 square landing, 1 entrance, 3 climbing bars, 1 metal bar over the slide, 4 metal fittings to be installed in the ground

| | |
|-----------------------|----------|
| Model type | Modulair |
| Serial number | 1132EPON |
| Equipment name | Tower 5 |

Join the action!

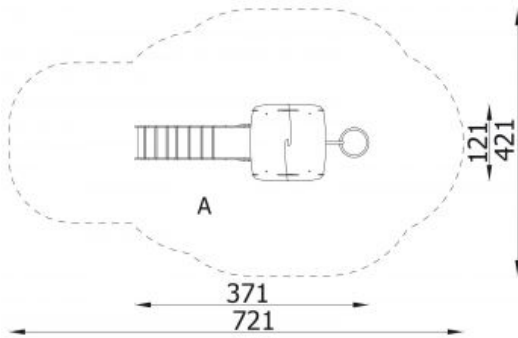

| | |
|--|--|
| Product line | Action Orbis Wood Modulair |
| Age range | 3 - 12 |
| Unit measurements | 125cm x 430cm x 330cm |
| Required surface area | 400cm x 860cm |
| Impact area | 28m ² |
| Free height of fall | 137cm |
| Material | Glue-laminated wood, turned cylindrically, milled. Construction installed in the ground on galvanized steel anchors. Roofs and guards made of polythene HDPE panels. |
| Heaviest part | 90kg |
| Largest part | 80cm - 350cm |
| Spare parts | Available |
| Installation time without grondwork | 6 hour(s) / 3 person(s) |
| Special tools | Included |
| Anchoring | Steel, galvanized anchors + concrete blocks. Depth of installing: 60 cm |
| Remarks | This equipment is also available with hot dip galvanized posts. Prices on request. |

