

Installation Instructions

Surface Fixed

Babel Drum
Page 1 of 2



Instrument Components:



Metric Conversion:
850mm/ 33 15/32"
855mm/ 33 21/32"
1.5m/ 59"

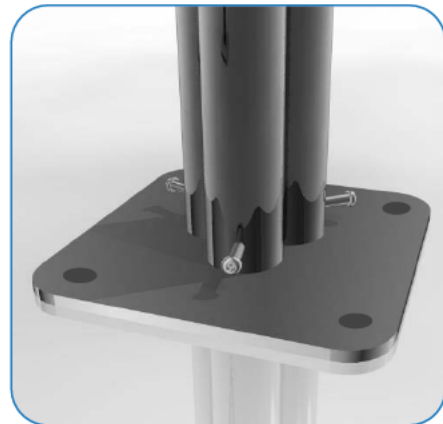

Weight of heaviest part 17.5kg (Large Babel Drum)
Weight of heaviest part 13.4kg (Small Babel Drum)

1. Unpack ground fixing legs 3no.

2. Lay packaging out on floor or assemble on non-abrasive surface to prevent marking of polished stainless steel.

3. Align holes on legs to holes on surface fixing (opposite end to polished domes) and secure in place using 3no. M10 x 30mm Screws
Tools required TX 45 Driver Bit)

4. Invert assembled frame so domed ends face upwards.

5. Place 8mm Hex Key supplied into hole in leg and lock into internal bolt.

6. Remove Black Cap opposite side of leg and keeping Hex Key in place, slide black polyurethane damper over bolt until flush with end of bolt. Repeat for other 2 legs

7. Unpack babel drum leaving black film in place to protect.

8. Align holes in side of babel drum with bolts on legs.

9. Using 8mm Hex Key screw bolts into drum to secure in place.
Use thread locking solution
All hole locations are laser cut for accuracy to ensure holes in drum align perfectly with legs.

10. Using TX40 driver provided secure M8 x 25mm security bolts into external holes in legs 3no. Use thread lock solution

11. Locate Babel Drum in desired location and mark holes to fix to desired surface.

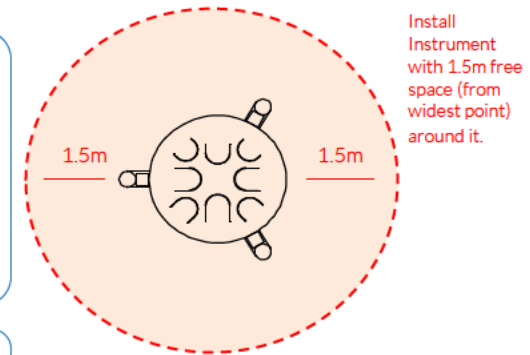

12. Fix to Surface using recommended ground anchors (Ground Anchors are not supplied)

13. Make sure all fixings are covered and secure using cover caps provided

850mm from Plate

855mm from Plate

CAUTION: Drum surface can get hot in direct sunlight, if possible install in shaded areas.

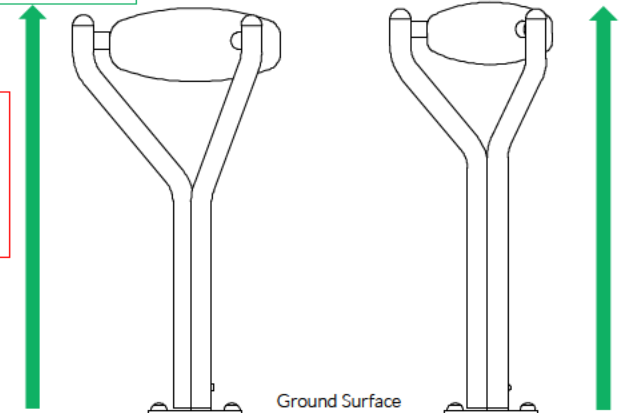

Large 8 note

Small 6 note



Ground Fix Components:





Ground Anchors not supplied

Spares available from percussionplay.com or from your local distributor

22 Kg
13.4 Kg

Tools:

-  x1 TX 45 Driver B t
-  x1 Hex T Key
-  x1 TX 40 Driver Bit

Surface Fixed

Babel Drum
Page 2 of 2



Instrument Components:

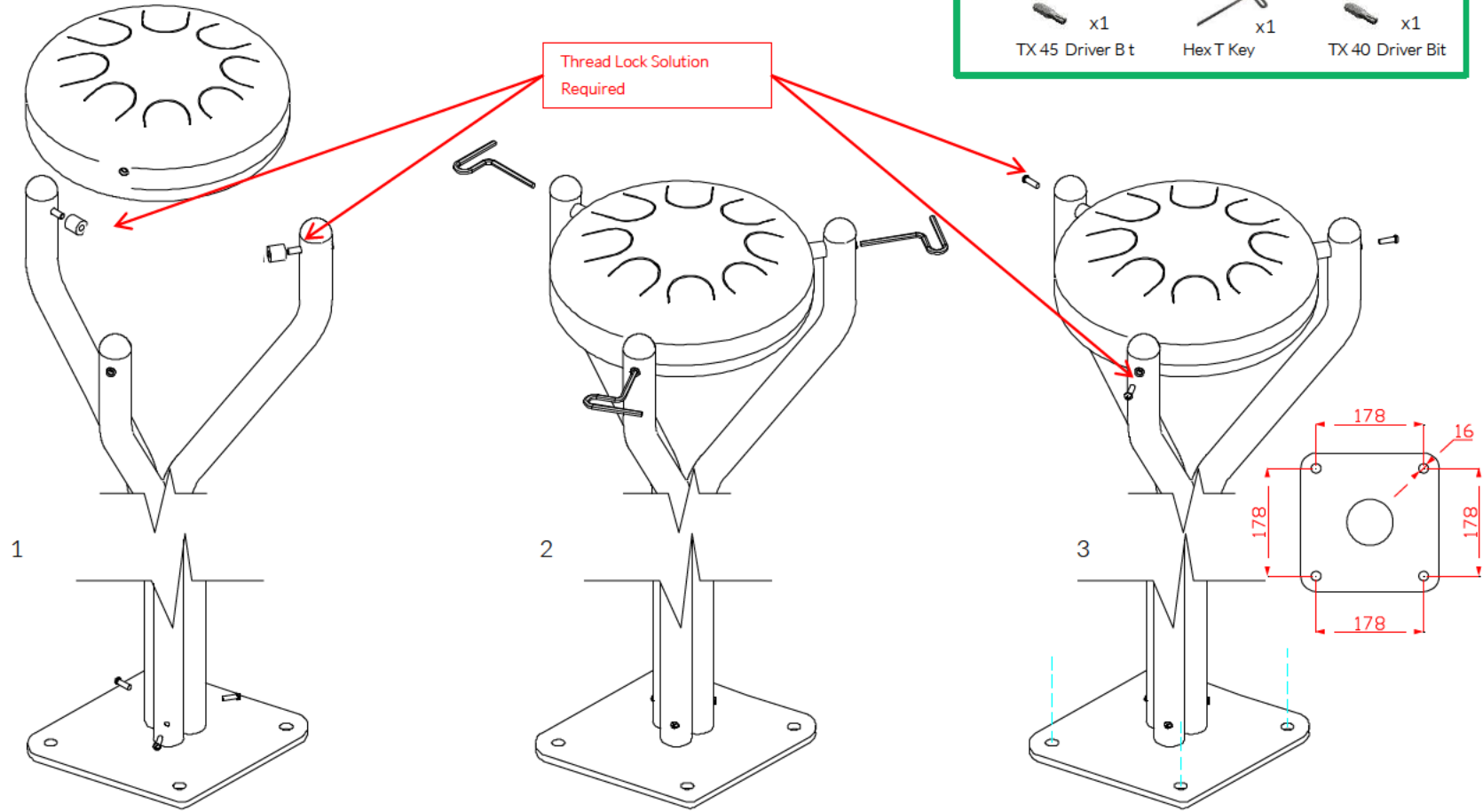

Thread Lock Solution Required

Thread Lock Solution Required

1. Locate the Surface fix Plate into the leg of the instrument.

2. Fix instrument to Surface fix plate using M10 Screws and use **thread locking solution** to prevent fixings working loose.

3. Fix Surface Plate to the ground surface **Ground Anchors Not provided** cover fixings with caps provided

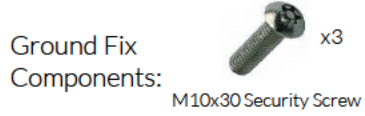

Ground Anchors not supplied

Spares available from percussionplay.com or from your local distributor

22 Kg
13.4 Kg