

Installation Instructions

Ground Fixed

Tubular Bells
Page 1 of 2



Instrument Components:

Tubular Bells are pre-assembled

Metric Conversion:
250mm/ 10"
400mm/ 16"
500mm/ 19 11/16"
1.5m/ 59"
2152mm/ 84 23/32"

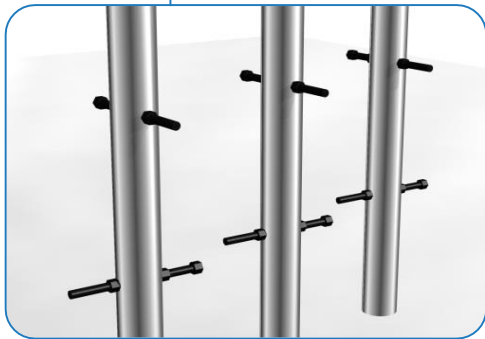
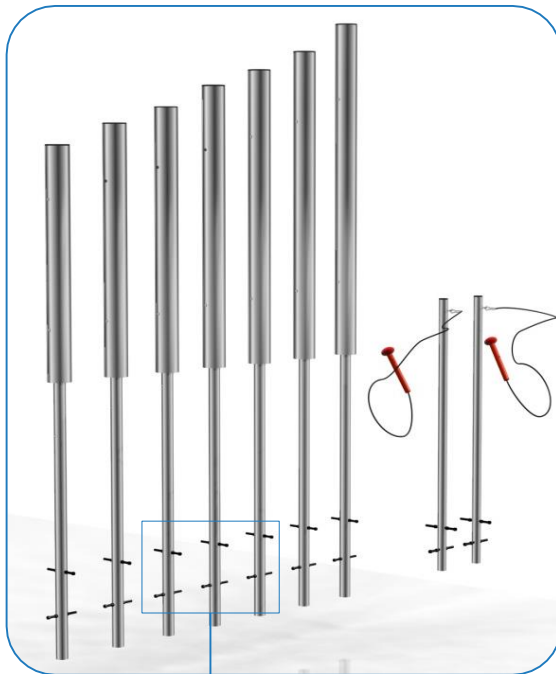

Weight of heaviest part 10kg (XXL Bell)

1. Using M10 nuts and 200mm bolts supplied locate through pre drilled holes and secure bolts in place to support in ground pole in concrete. **2 bolts per leg** at 90 degree angles

2. Excavate 7 holes for Tubular Bells 250mm diameter by 500mm deep. **2 further holes** will be needed for the beater poles according to layout of Bells at 250mm diameter and 400mm deep.

3. Locate (lower) legs into holes making sure they are vertical and level prior to concreting in place

4. Once happy with location of the Tubular Bells, **fill** holes using rapid hardening concrete. Be sure to compact concrete around legs and leave to dry according to manufactures guidelines

In ground fixing 500mm for each chime and 400mm for beater poles

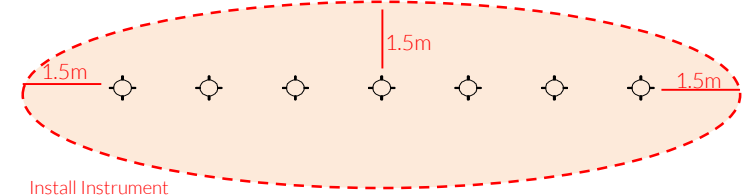

Install Instrument with 1.5m free space (from widest point) around it.

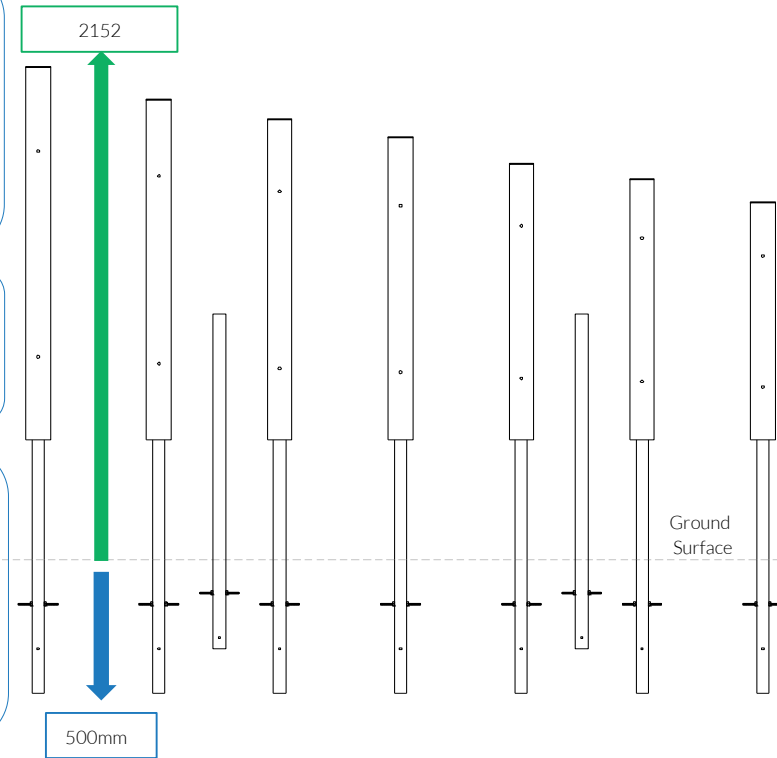

Ground Fix Components:

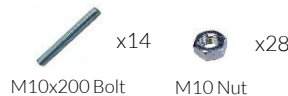

Spares available from percussionplay.com or from your local distributor

59 Kg

Ground Fix Post Installation

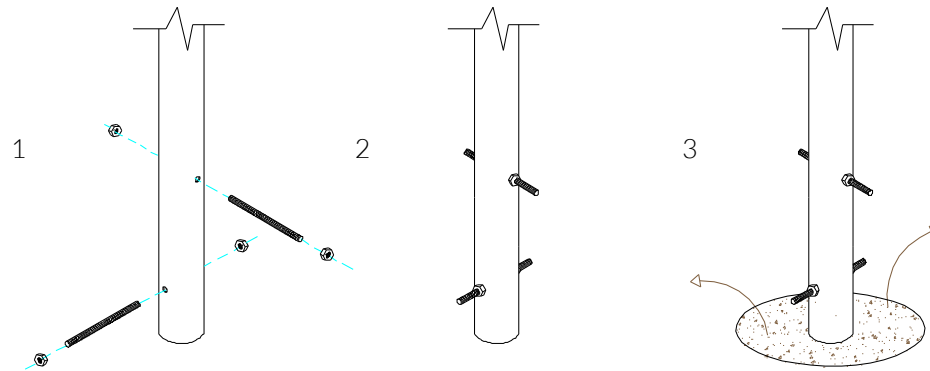

1 Insert M10x 200 Threaded bar into pre drilled holes in Ground Fixing Post

2 Fix M10x 200 Threaded bar in place using M10 Nuts

3 Excavate 7 holes with a 250mm diameter tapering down to 350mm diameter and 550mm depth

Foundations should not present a hazard. These foundations are recommended as a guide, for more information on foundation details for various surface see Part 1 of BS EN 1176.



5 Compact base of hole with 50mm of aggregate. Lower ground Fix post attached to instrument into hole (check instrument straight and level before filling with concrete)

6 Fix hole with fast drying concrete to manufacturers specifications.

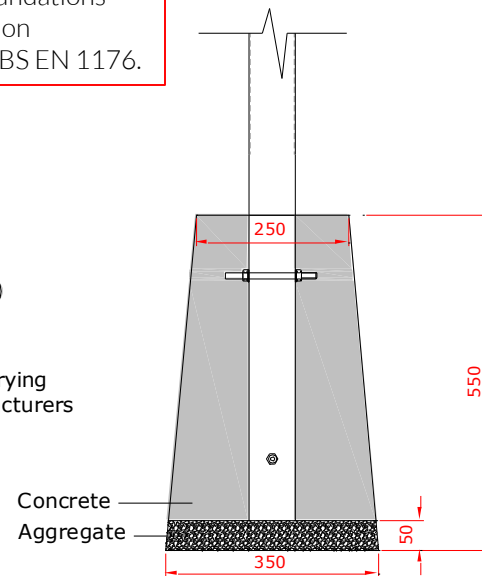

500mm max depth 7x Tubular Bells
400mm max depth 2X Beater Poles

Ground Fixed

Tubular Bells
Page 2 of 2



Components:

-  x14
M10x200 Threaded Bar
-  x28
M10 BZP Nut

Metric Conversion:
50mm/ 2"
250mm/ 10"
350mm/ 14"
400mm/ 16"
450mm/ 18"
500mm/ 19 11/16"
550mm/ 21 21/32"