

Installation Instructions

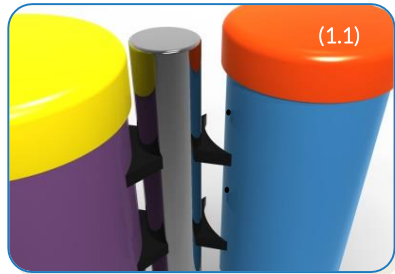

Weight of heaviest part **3.8kg** (Large drum Small Congas)
 Weight of heaviest part **4.5kg** (Large drum Medium Congas)
 Weight of heaviest part **5.2kg** (Large drum Large Congas)

1. Attach the steel leg to each of the congas with the M10x50 security screws, square washers and PU mounts. **(1.1)** (See Assembly Guide)

2. Attach Surface Fixing posts to legs **(1.2)** (See Ground Fix Post Installation Sheet)

3. **Locate Plate** in desired location and mark holes to fix to desired surface.

4. Fix to Surface using recommended ground anchors not supplied

5. Make sure all fixings are covered and secure using cover caps provided

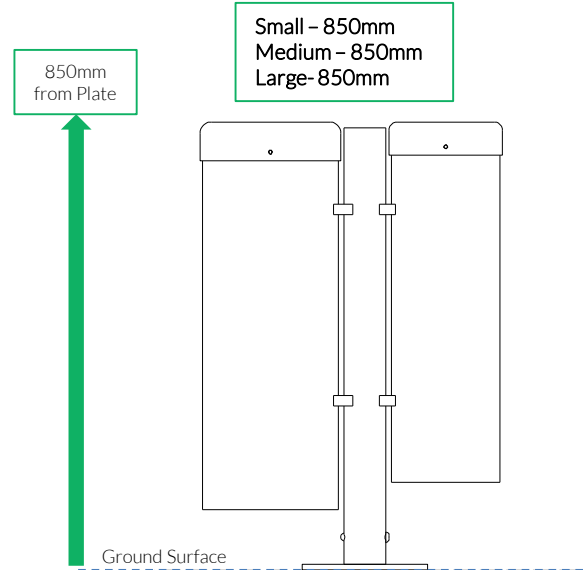
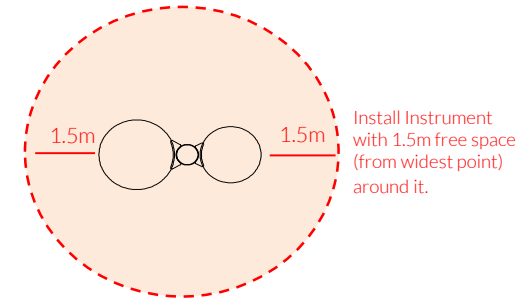





Surface Fixed

Congas
Page 1 of 2





Instrument Components:

-  x4
- M10x50 Security Screw
-  x4
- M10x50x3 Square washer
-  x2
- PU 200 Mount
-  x2
- PU 250 Mount

Metric Conversion:
 178mm/ 7"
 850mm/ 33"
 1.5m/ 59"



Surface Fix Components:

-  x1
- M10x70 Security Screw
-  x1
- M10 Barrel Nut
-  x4
- 2 Part Cover Cap

Ground Anchors not supplied

Spares available from percussionplay.com or from your local distributor

**14.8 Kg
15 Kg
20 Kg**

Assembly Guide PPCONG

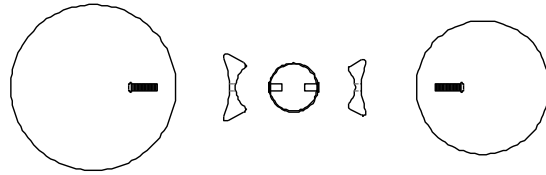

PPCONG PLAN

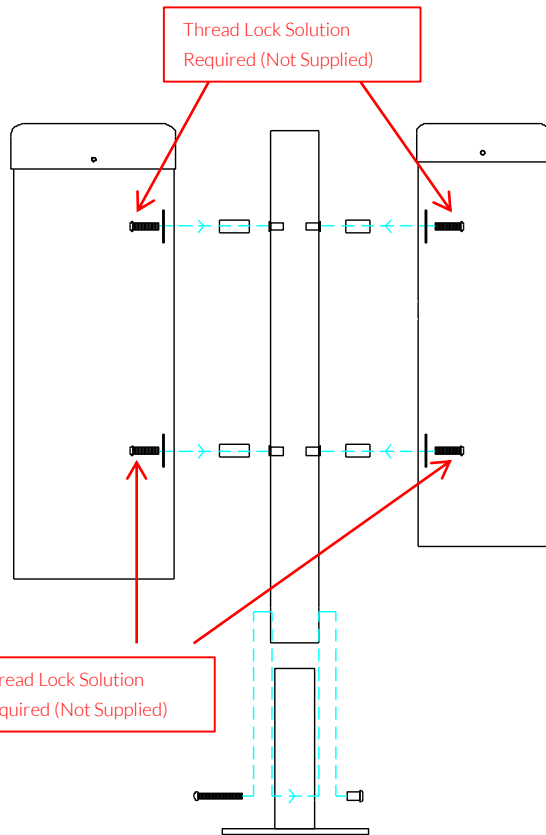

PPCONG FRONT

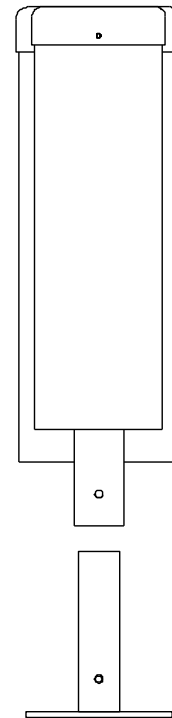

PPCONG SIDE

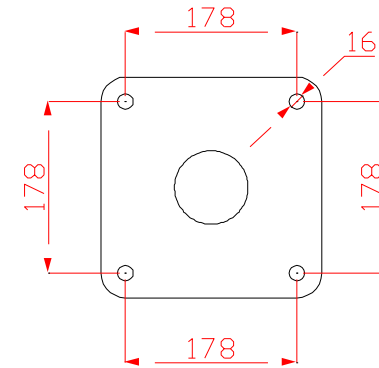

Tools:

- x2 TX 45 Driver Bit

COMPONENTS LIST:

- M10x50 Security Screw X4
- M10x50x3 square washer X4
- PU MOUNT 200 X2
- PU MOUNT 250 X2
- M10x70 Pin torx X1
- M10 Barrel Nut Pin torx X1

Surface Fixed

Congas
Page 2 of 2



Instrument Components:

- x4 M10x50 Security Screw
- x4 M10x50x3 Square washer
- x2 200 Mount
- x2 250 Mount



Surface Fix Components:

- x1 M10x70 Security Screw
- x1 M10 Barrel Nut
- x4 2 Part Cover Cap

Ground Anchors not supplied

Spares available from percussionplay.com or from your local distributor

14.8 Kg
15 Kg
20 Kg

Installation Instructions

Surface Fixed

Duo
Page 1 of 3



Instrument Components:

-  x8
M8 Nyloc Nut
-  x4
M6x20 Security Screw
-  x8
2 Part Cover Cap
-  x2
M6 Saddle Strap

Metric Conversion:
178mm/ 7"
232mm/ 9"
750mm/ 29 1/2"
850mm/ 33"
1.5m/ 59"

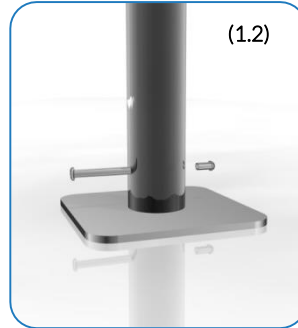
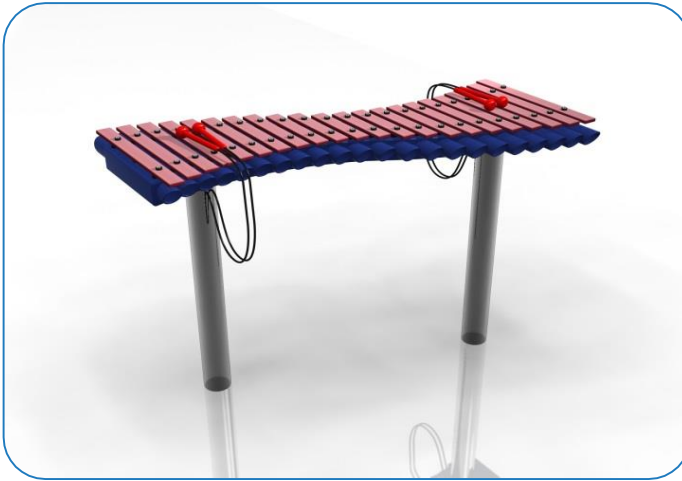

Weight of heaviest part **14kg** (Duo)

1. Attach the steel legs to the base of the instrument with the M8 Nyloc Nuts and 2 part security caps. **(1.1)** (See Assembly Guide)

2. Attach Surface Fixing posts to legs **(1.2)** (See Ground Fix Post Installation Sheet)

3. **Locate Plate** in desired location and mark holes to fix to desired surface.

4. Fix to Surface using recommended ground anchors not supplied

5. Make sure all fixings are covered and secure using cover caps provided

6. Attach the 1 pair of beater to the saddle strap on each leg. **(1.3)**

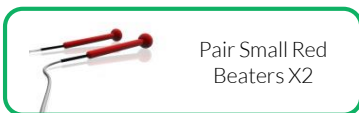
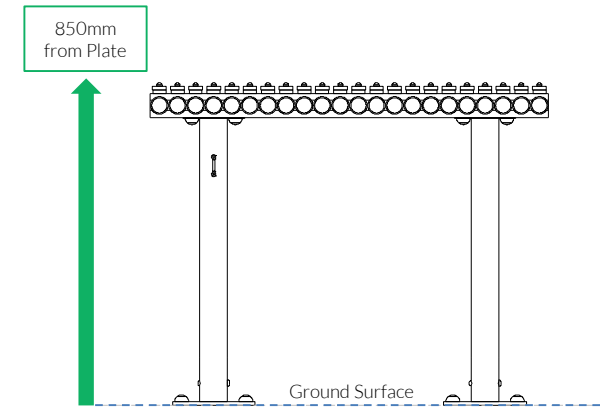
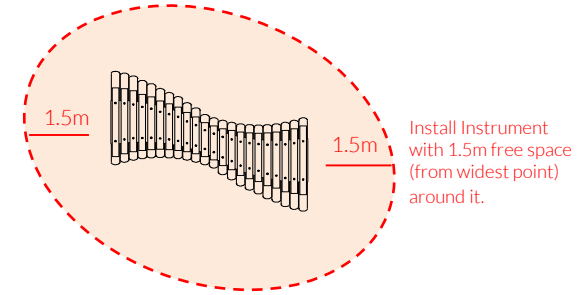

Surface Fix Components:



Ground Anchors not supplied

Spares available from percussionplay.com or from your local distributor

28 Kg

Assembly Guide PDDUO

Tools:

TX 30 Driver Bit x1
TX 45 Driver Bit x2

Surface Fixed
Duo
Page 2 of 3

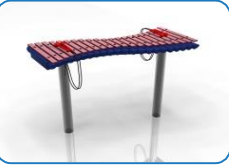

Instrument Components:

- x8
M8 Nyloc Nut
- x4
M6x20 Security Screw
- x8
2 Part Cover Cap
- x2
Cap
- x2
M6 Saddle Strap

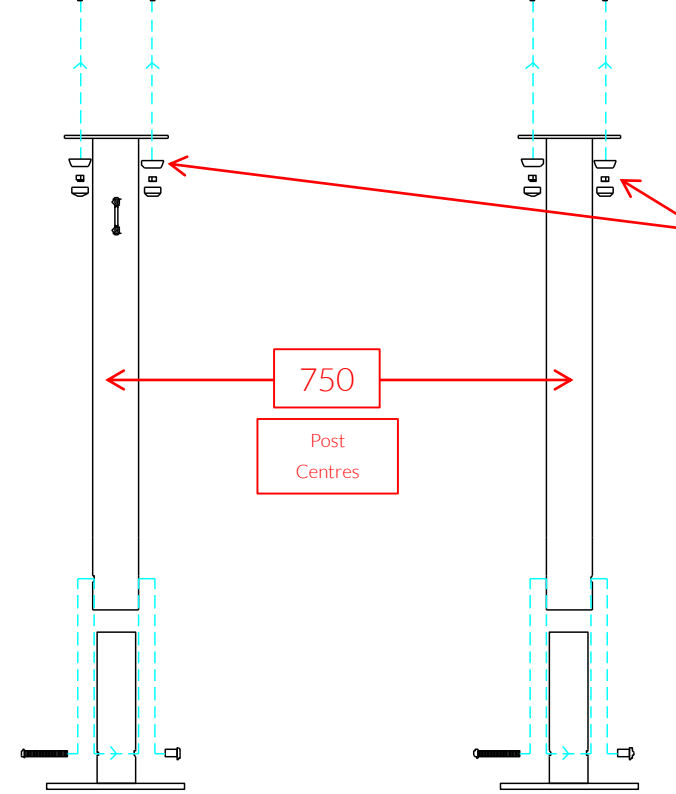
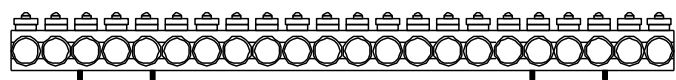

PPDUO FRONT

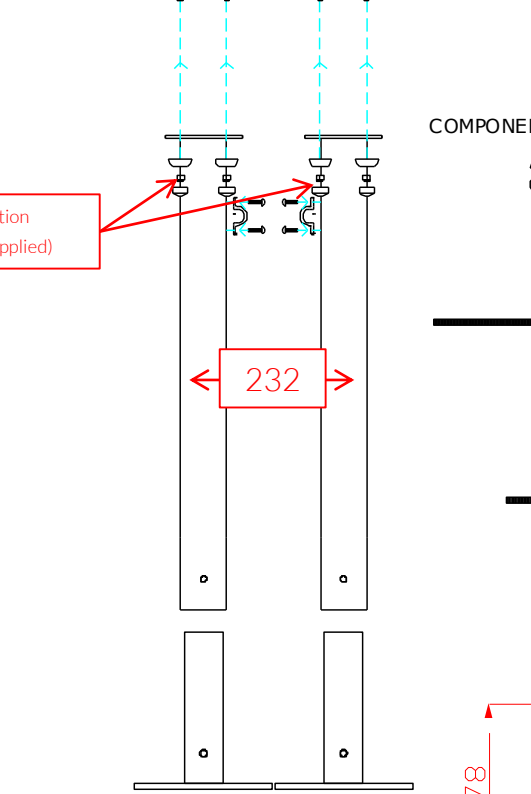
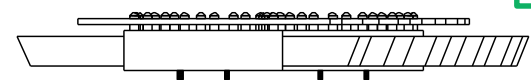

PPDUO SIDE

- COMPONENTS LIST:**
- 2 Part Cover Cap X8
 - M8 Nyloc nut X8
 - M10 Nut X8
 - M10x200 Threaded Bar X4
 - Saddle Strap X2
 - M6x20 Pin torx X4
 - M10x70 Pin torx X2
 - M10 Barrel Nut Pin torx X2

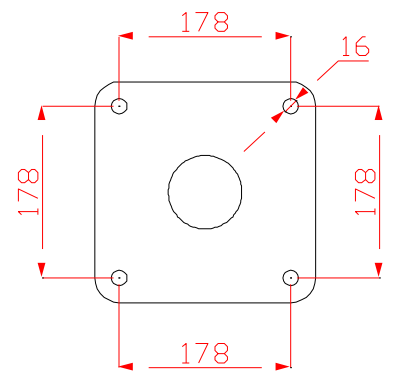

Thread Lock Solution Required (Not Supplied)



Pair Small Red Beaters X2

Surface Fix Components:

- x2
M10x70 Security Screw
- x2
M10 Barrel Nut
- x8
2 Part Cover Cap

Ground Anchors not supplied

Spares available from percussionplay.com or from your local distributor

28 Kg

Tools:

 x2
 TX 45 Driver Bit

Surface Fixed

Duo
Page 3 of 3

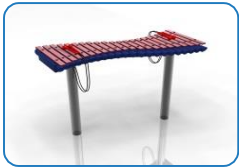

Components:



x2

M10 Barrel Nut



x2

M10x70 Security Screw



x8

2 Part Cover Cap

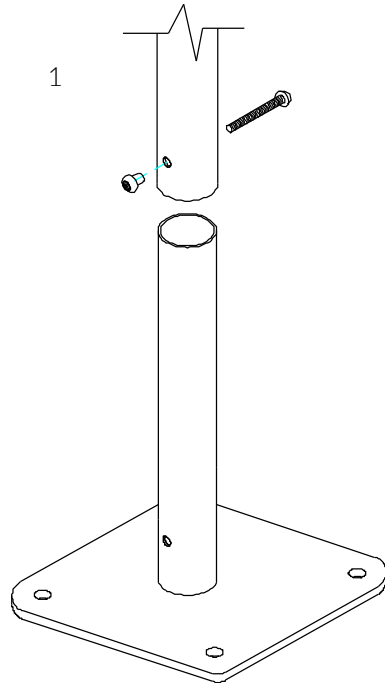

1
 Locate the Surface fix Plate into the leg of the instrument.

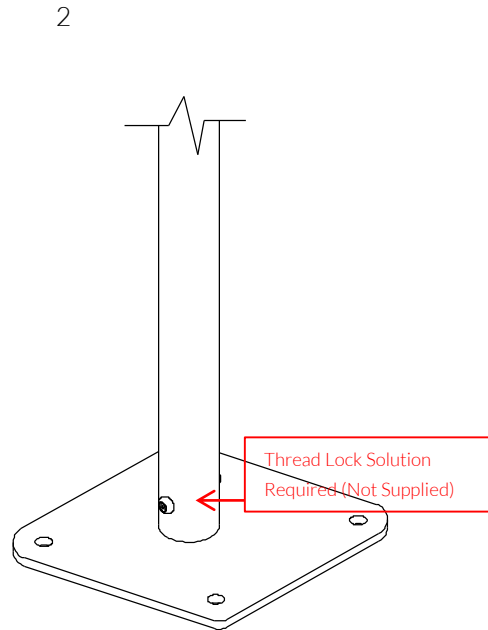

2
 Fix instrument to Surface fix plate using M10 bolt and Barrel Nut and use **thread locking solution** to prevent fixings working loose.

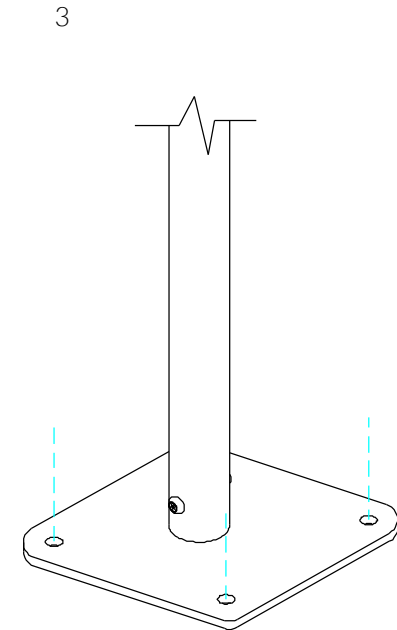

3
 Fix Surface Plate to the ground surface **Ground Anchors Not provided** cover fixings with caps provided

Thread Lock Solution
Required (Not Supplied)



MADE IN
BRITAIN

BSEN 1176

Installation Instructions

Surface Fixed Emperor Chimes Page 1 of 2



Instrument Components:

Emperor Chimes are pre-assembled

Metric Conversion:
100mm/ 4"
1.5m/ 59"
1785mm/ 70"
2490mm/ 98"

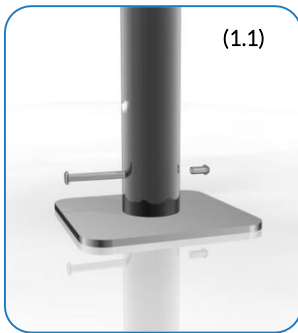

Weight of heaviest part 25kg (XL Chime)

1. Attach Surface Fixing plates to the base of each chime (1.1) (See Surface Fix Plate Installation Sheet)

2. Locate Chimes to desired location and mark holes to fix to desired surface.

4. Fix to Surface using recommended ground anchors not supplied

5. Make sure all fixings are covered and secure using cover caps provided

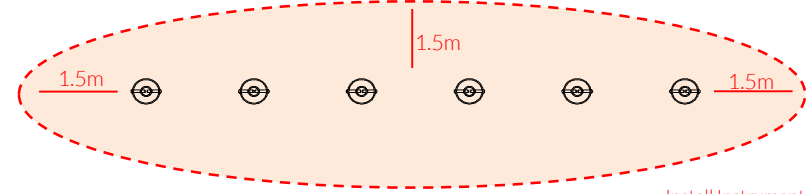

Install Instrument with 1.5m free space (from widest point) around it.

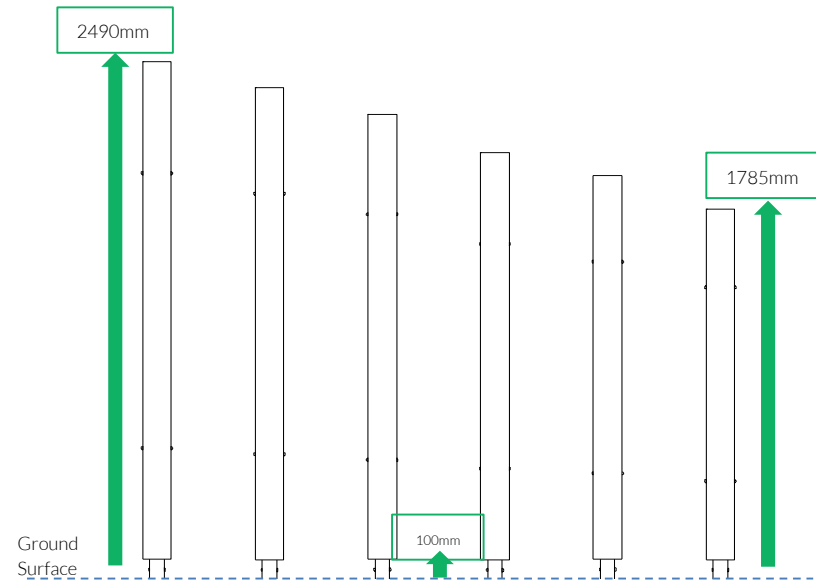

Played with hands

Surface Fix Components:

x6
M10x50 Security Screw

x6
M10 Barrel Nut

x24
2 Part Cover Cap

Spares available from percussionplay.com or from your local distributor

117 Kg

Surface Fix Plate Installation

Tools:

 x2
TX 45 Driver Bit

Ground Fixed
Emperor Chimes
Page 2 of 2



Components:



x6

M10 Barrel Nut



x6

M10x50 Security Screw



x24

2 Part Cover Cap

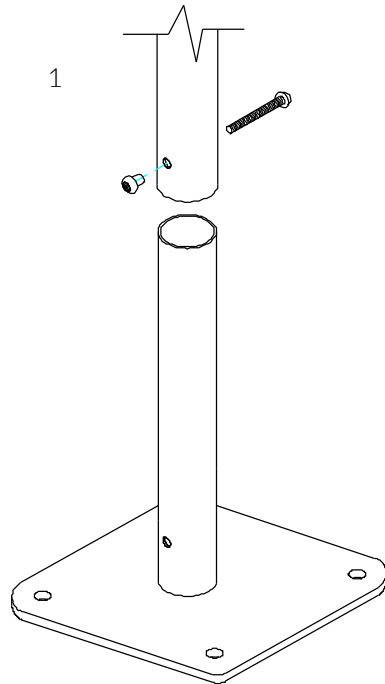

1
Locate the Surface fix Plate into the leg of the instrument.

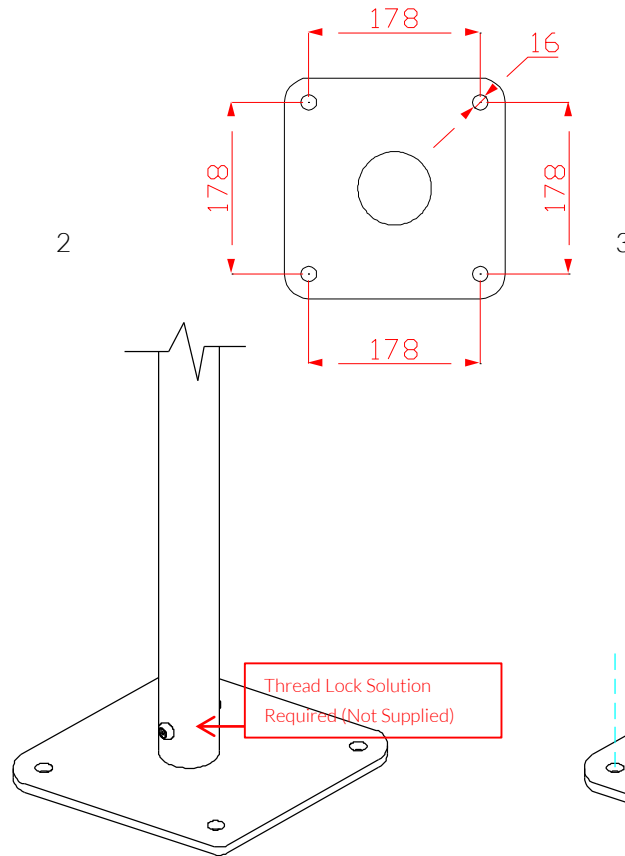

2
Fix instrument to Surface fix plate using M10 bolt and Barrel Nut and use **thread locking solution** to prevent fixings working loose.

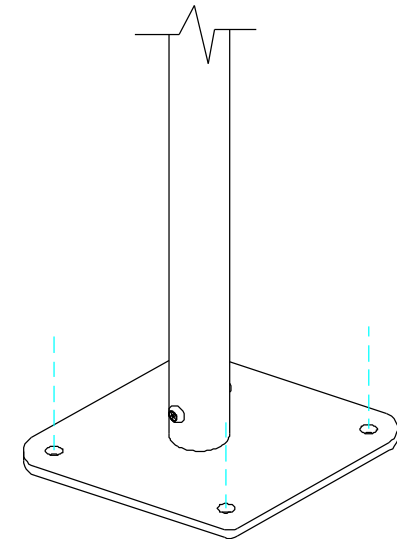

3
Fix Surface Plate to the ground surface **Ground Anchors Not provided** cover fixings with caps provided

Thread Lock Solution
Required (Not Supplied)

Repeat Parts 1-3 for all 6 chimes



MADE IN
BRITAIN

BSEN 1176

Installation Instructions

Surface Fixed

Freechimes
Alto/ Soprano
Page 1 of 3



Metric Conversion:
600mm/ 24"
800mm/ 31"
950mm/ 37"
1200mm/ 47"
1.5m/ 59"

Weight of heaviest part **8.35kg** (Freechimes)

1. Carefully lay 2 x legs on a **level surface** and check distance between **legs is equal**. Line up pre drilled holes in the backboards with the holes in legs and ensure the instrument is aligned square with the legs. **Fix in place** using **M8x40mm screws** supplied (see installation guide)

2. Attach Surface Fixing posts to legs (See **Surface Fix Post Installation Sheet**)

3. Locate Instrument in desired location and mark holes to fix to desired surface.

4. Fix Surface Plate to level surface using Coachscrews, Rawlbolts, chemical anchors or similar as deemed appropriate by Installer.

(It is your responsibility to ensure that the existing surface is suitable to receive the appropriate fixing)

5. Make sure all fixings are covered and secure using cover caps provided

6. Beaters can be fixed to Steel posts with fixings provided

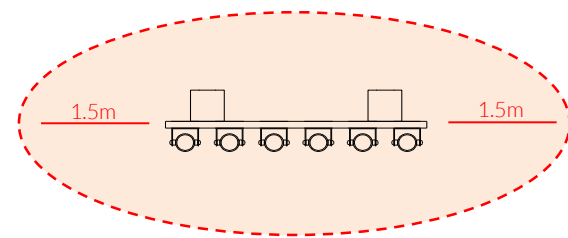

Install Instrument with 1.5m free space (from widest point) around it.

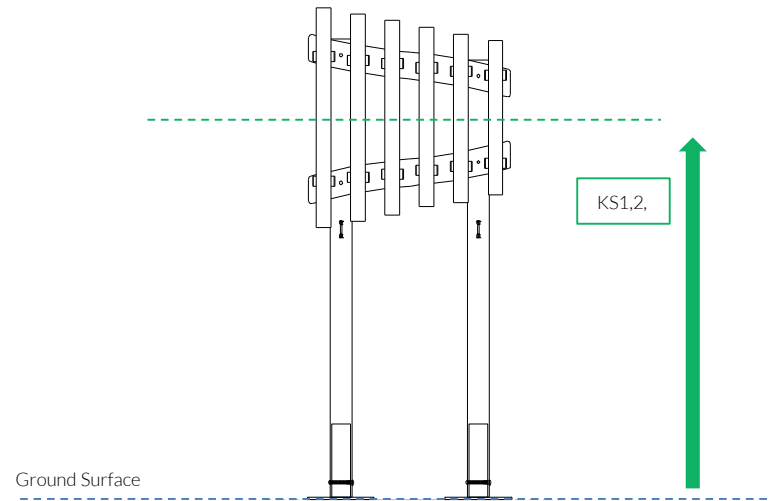

Ground Surface

KS1,2

KS1 - 800mm
KS2 - 950mm
Adult - 1200mm



Pair Small Beaters X1

Ground Fix Components:



2 Part Cover Cap x8

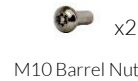

M10 Barrel Nut x2





M10x70 Security Screw x2

Spares available from percussionplay.com or from your local distributor

16 Kg

Tools:

 x1
 x2

TX 30 Driver Bit TX 45 Driver Bit

Surface Fixed

Freechimes
Alto/ Soprano
Page 2 of 3



COMPONENTS LIST:

-  Saddle Strap X2
-  M6x20 Pin torx X4
-  M8 X 40 Pin Torx X4
-  M10x70 Pin torx X2
-  M10 Barrel Nut Pin torx X2

Thread Lock Solution
Required (Not Supplied)

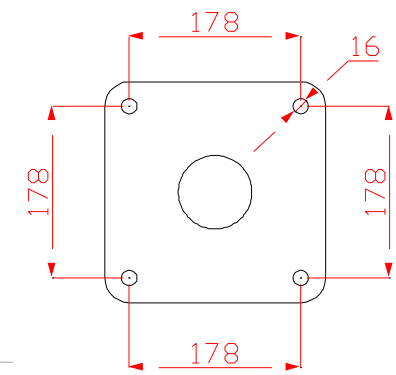

709mm Diatonic Post Centres
472mm Pentatonic Post Centres

Thread Lock Solution
Required (Not Supplied)



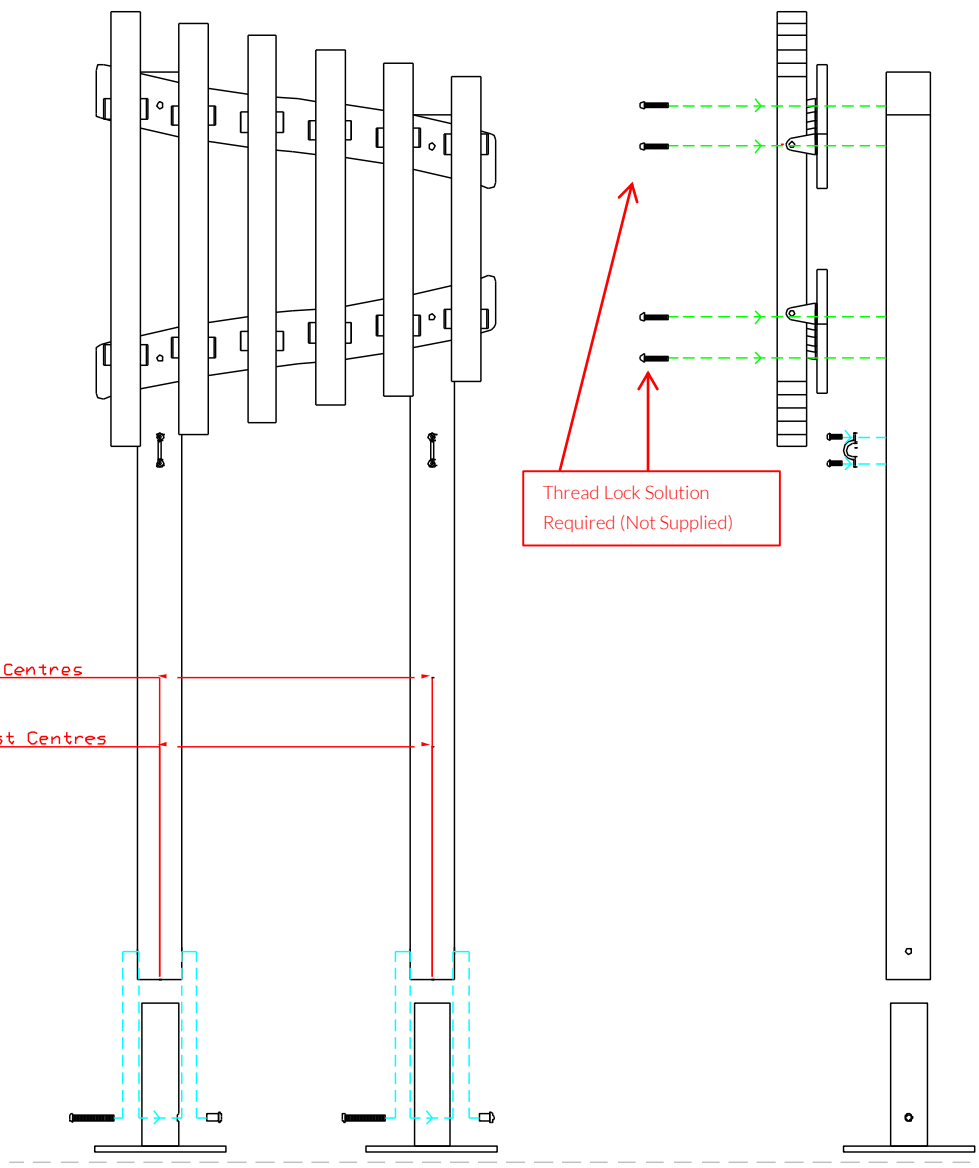

Components:

-  Eye Straps X2
-  M6x20mm Secure Screw X4
-  M8x40mm Secure Screw X4

Pair Small Beaters X1

Ground Fix Components:

-  x8
-  x2
-  x2

Spares available from
percussionplay.com or from your
local distributor

16 Kg

Tools:

 x2
TX 45 Driver Bit

Surface Fixed

Freechimes
Alto/ Soprano
Page 3 of 3



Components:

 x2

M10 Barrel Nut

 x2

M10x70 Security Screw

 x8

2 Part Cover Cap

Thread Lock Solution
Required (Not Supplied)



MADE IN
BRITAIN

BSEN 1176

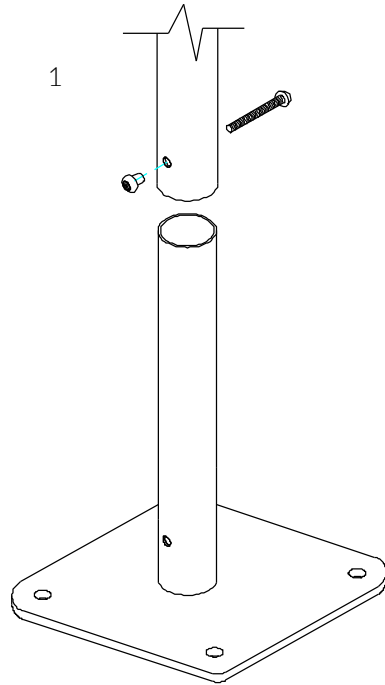

Locate the Surface fix Plate into the leg of the instrument.

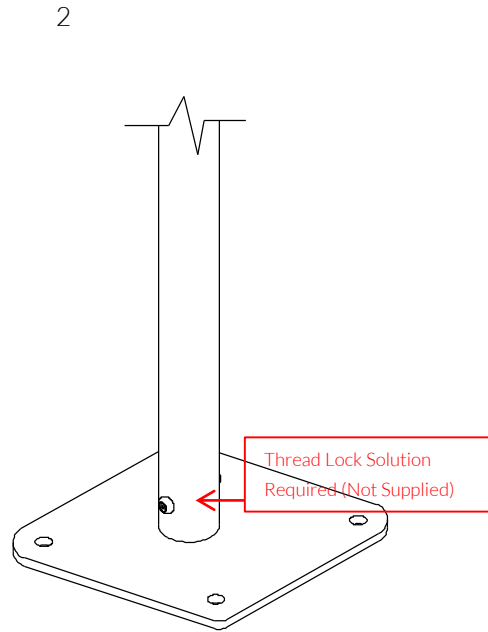

Fix instrument to Surface fix plate using M10 bolt and Barrel Nut and use **thread locking solution** to prevent fixings working loose.

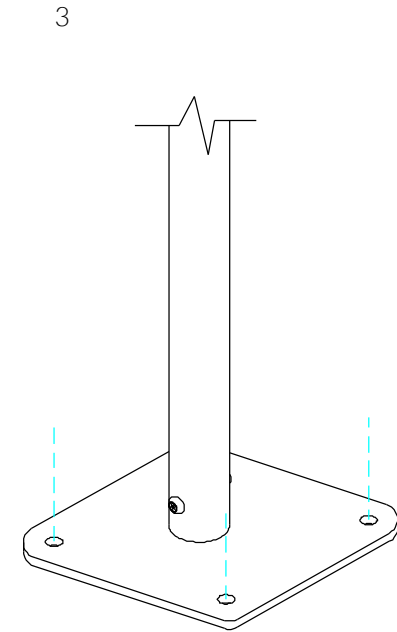

Fix Surface Plate to the ground surface **Ground Anchors Not provided** cover fixings with caps provided